

Agenda of the Regular Meeting

of the City Council of the

**CITY OF DARIEN**

April 15, 2013

7:30 P.M.

1. Call to Order
2. Pledge of Allegiance
3. Roll Call
4. Declaration of Quorum
5. Questions, Comments and Announcements — General (This is an opportunity for the public to make comments or ask questions on any issue – **3 Minute Limit Per Person, Additional Public Comment Period - Agenda Item 18**).
6. Approval of Minutes — [April 1, 2013](#)
7. Receiving of Communications
8. Mayor's Report
  - A. Darien Chamber of Commerce Update
9. City Clerk's Report
10. City Administrator's Report
11. Department Head Information/Questions
12. Treasurer's Report
  - A. Warrant Number — [12-13-21](#)
  - B. Monthly Report — [March 2013](#)
13. Standing Committee Reports
14. Questions and Comments — Agenda Related (This is an opportunity for the public to make comments or ask questions on any item on the Council's Agenda.)
15. Old Business
16. Consent Agenda
  - A. Consideration of a Motion to Approve:
    - [The Fourth Annual Hornet Hustle 2013](#), a 5K Run/1 Mile Walk, Sunday May 5, 2013 Beginning at 8:20 A.M and Authorize Additional Police and Municipal Service Staffing Along with Additional Signage, Barricades and City Expense for This Event and Authorize the Chief of Police to Finalize the Details of This Event with Hinsdale South Athletic Club
    - Use of the Right Half of the Following Streets for the Hornet Hustle 2013 which Begins at the Northwest Corner of Darien Community Park and Proceed as Follows:  
**5K Run** - 71st Street to Richmond Avenue; South on Richmond Avenue and Following Cherokee Drive to Darien Lane; North on Darien Lane and Following Timber Lane to Seminole Drive; North on Seminole Drive to 71st Street; West on 71st Street to Beechnut Lane to Hinsbrook Avenue; East on Hinsbrook Avenue to Wilmette Avenue; North on Wilmette Avenue to 69th Street; East on 69th Street to Bentley Avenue; South on Bentley Avenue to 71st Street; East on 71st Street to Northwest Corner of Darien Community Park with Access for Emergency Vehicles and Local Traffic at All Times; AND  
**1 Mile Walk** – 71st Street to Richmond Avenue; North on Richmond Avenue to Maple Lane; East on Maple Lane to Bentley Avenue; South on Bentley Avenue to 71st Street; East on 71st Street to Northwest Corner of Darien Community Park with Access for Emergency Vehicles and Local Traffic at All Times
  - B. Consideration of a Motion to Approve [a Resolution Authorizing the City Administrator to Purchase a Security Camera System](#) to Monitor 1041 S. Frontage Road from Andromeda in an Amount not to Exceed \$16,208.95
  - C. Consideration of a Motion to Approve [a Resolution Temporarily Waiving Building Permit Fees](#) to Encourage Home Improvements, Maintenance and Upgrades through April 30, 2014
17. New Business
  - A. Consideration of a Motion to Approve a [Resolution Stating the Position of the Mayor and City Council Regarding the City of Darien's](#)

[Funding of Crossing Guards for School District 61](#)

18. Questions, Comments and Announcements — General (This is an opportunity for the public to make comments or ask questions on any issue.)
19. Adjournment

A WORK SESSION WAS CALLED TO ORDER AT 7:00 P.M. BY MAYOR WEAVER FOR THE PURPOSE OF REVIEWING ITEMS ON THE APRIL 1, 2013 AGENDA WITH THE CITY COUNCIL. THE WORK SESSION ADJOURNED AT 7:05 P.M.

THE 2013-2014 BUDGET PUBLIC HEARING WAS CALLED TO ORDER AT 7:05 P.M. BY MAYOR WEAVER. THE PUBLIC HEARING ADJOURNED AT 7:07 P.M.

**Minutes of the Regular Meeting**

**of the City Council of the**

**CITY OF DARIEN**

**APRIL 1, 2013**

1. **CALL TO ORDER**

The regular meeting of the City Council of the City of Darien was called to order at 7:30 P.M. by Mayor Weaver.

2. **PLEDGE OF ALLEGIANCE**

Boy Scout Troop #56 led the Council and audience in the Pledge of Allegiance.

3. **ROLL CALL** — The Roll Call of Aldermen by Deputy Clerk Dubman was as follows:

Present:	Tina M. Beilke	John F. Poteraske, Jr.
	Joseph A. Marchese	Ted V. Schauer
	Sylvia McIvor	Joerg Seifert

Absent: Halil Avci

Also in Attendance: Kathleen Moesle Weaver, Mayor  
Lynn Dubman, Deputy Clerk  
Michael J. Coren, City Treasurer  
Bryon D. Vana, City Administrator  
Scott Coren, Assistant City Administrator  
Daniel Gombac, Director of Municipal Services  
Ernest Brown, Police Chief  
John Cooper, Deputy Chief

4. **DECLARATION OF A QUORUM** — There being six aldermen present, Mayor Weaver declared a quorum.

5. **QUESTIONS, COMMENTS AND ANNOUNCEMENTS - GENERAL**

There were none.

6. **APPROVAL OF MINUTES** – March 18, 2013

Mayor Weaver noted that, during the Work Session, the spelling of Jack Morge’s name on Page 2, Paragraph 3, was corrected.

It was moved by Alderman Marchese and seconded by Alderman Beilke to approve the minutes of the City Council Meeting of March 18, 2013, as amended.

Roll Call: Ayes: Beilke, Marchese, Poteraske, Schauer, Seifert

Abstain: McIvor

Nays: None

Absent: Avci

Results: Ayes 6, Nays 0, Absent 1

**MOTION DULY CARRIED**

7. **RECEIVING OF COMMUNICATIONS**

Alderman Marchese advised the Bailey Park Subdivision Homeowners Association has expressed concerns with speeding on Bailey Road, and safety at the intersection of Bailey and Plainfield Roads. Director Gombac will have a traffic counter placed at Barrymore and Lakeview for seven days to explore the speeding issue. Director Gombac provided a brief history of the problems and accidents motorists have experienced at the intersection of Bailey and Plainfield Roads. He enumerated the steps the City has taken in an attempt to address this issue. Chief Brown will gather statistical information on the accidents, and Director Gombac will continue to apply for grants in order to either reconfigure Bailey Road to allow for a dedicated left turn lane at a cost of \$750,000, or provide for the installation of a traffic signal. Alderman Schauer remarked how dangerous the intersection is, and suggested a traffic signal would be better than reconfiguration of the road.

Alderman McIvor announced District 66 will be holding a Big Bang S.T.E.M. (Science, Technology, Engineering and Math) Night at Lakeview Junior High on April 3, 2013 at 6:00 P.M.

Alderman Beilke received communication from Tami Hollendonner, who noted the unkempt condition at Crest Basin could affect prospective buyers, and spoke against postponement of the project.

8. **MAYOR'S REPORT**

A. **SWEARING IN OF NEW SERGEANT – OFFICER DAVID STOCK**

Deputy Chief Cooper provided a history of Officer Stock's career, which began with service in the U.S. Army. Officer Stock served with the Lemont Police Department for 2 ½ years, and joined Darien's force on July 28, 1988. He has served as a Field Training Officer, Evidence Technician, Breath Operator, Bicycle Officer, Juvenile Officer, and Property Control Officer. He also served in the Detective Division for seven years from 2004 to 2011. Officer Stock created the first proposal for a K-9 unit which resulted in Darien's first. He also restructured the evidence/property room from the old police building to the new station in 1995.

Fire and Police Commissioner Mark Piccoli administered the Oath of Office to David Stock.

Deputy Chief Cooper extended an invitation to celebrate Sergeant Stock's promotion with cake and coffee in the Police Department Training Room.

9. **CITY CLERK'S REPORT**

Deputy Clerk Dubman invited all to Meet and Greet the Mayor at City Hall on Monday, April 15, 2013 at 6:00 P.M.

10. **CITY ADMINISTRATOR'S REPORT**

Assistant Administrator Coren presented an overview of the ten-points of transparency utilized to communicate all aspects of City government to the residents.

11. **DEPARTMENT HEAD INFORMATION/QUESTIONS**

Chief Brown provided an overview of the transition from the DARE Program to the new Drug Awareness Program. He noted that each school district will take ownership of the program, and work in partnership with the Police Department. The program will be taught to students from 3<sup>rd</sup> grade through junior high by the teachers. Monthly meetings will be held to discuss and determine programming. The next meeting is scheduled for April 15, 2013 in the Police Department Training Room at 2:30 P.M. Chief Brown has found the parents to be fully engaged in the new program. He anticipates more forums will be held on various topics.

Director Gombac...

...announced Chuck's Southern Comforts Café will be holding two job fairs at their Darien location on April 5 and 6 from 9:00 A.M. to 5:00 P.M.

...advised that, as a courtesy to the residents, the City put out a request for proposal for treatment of the Emerald Ash Borer on private property trees. Tree & Turf Professionals will be providing this service and can be reached at 630-759-7389 or [thepros@treeandturf.com](mailto:thepros@treeandturf.com). In order to be successfully treated, trees must have a 60% healthy canopy. Evaluations will be conducted free of charge, and charges for treatment will be based on the diameter-by-height of the tree. The majority of Emerald Ash Borer infestation has been found in Ward 6. Director Gombac explained the process and advised that informational letters will be delivered to homes where parkway trees are treated.

...explained the delay in the Walmart expansion is due to the detailed architectural and engineering processes Walmart follows. Staff has been assured by Walmart that the project is moving forward.

Assistant Administrator Coren advised that the ComEd rates will be dropping significantly to 5.5 cents per kilowatt hour. The City's two-year low bid of 4.5 cents will continue to be a cost savings to the residents. The bid process, which will begin in December 2013 or January 2014, will not be as involved as the initial bid.

12. **TREASURER'S REPORT**

**A. WARRANT NUMBER 12-13-20**

It was moved by Alderman Seifert and seconded by Alderman Schauer to approve payment of Warrant Number 12-13-20 in the amount of \$33,133.50 from the General Fund; \$9,213.57 from the Water Fund; \$3,531.09 from the Motor Fuel Tax Fund; \$394.00 from the Capital Improvement Fund; \$242,260.47 General Fund Payroll for the period ending 03/23/13; \$20,522.69 from the Water Fund Payroll for the period ending 03/23/13; for a total to be approved of \$309,055.32.

**City Council Meeting**

**April 1, 2013**

Roll Call: Ayes: Beilke, Marchese, McIvor, Poteraske, Schauer, Seifert

Nays: None

Absent: Avci

Results: Ayes 6, Nays 0, Absent 1

**MOTION DULY CARRIED**

13. **STANDING COMMITTEE REPORTS**

**Municipal Services Committee** — Chairman Marchese advised the minutes of the February 25, 2013 Municipal Services Committee Meeting have been submitted to the Clerk’s Office, and the next meeting is scheduled for April 22, 2013 at 6:30 P.M in the Council Chambers.

**Police Committee** — Chairman McIvor announced the April 4, 2013 meeting of the Police Committee has been cancelled due to a lack of agenda items, and the next meeting is scheduled for May 2, 2013 at 6:00 P.M. in the Council Chambers.

**Administrative/Finance Committee** — Chairman Poteraske announced the next meeting of the Administrative/Finance Committee is scheduled for April 8, 2013 at 6:30 P.M. in the upstairs conference room.

14. **QUESTIONS AND COMMENTS – AGENDA RELATED**

Alderman Marchese explained that Consent Agenda Item S. will apply to all Administrative, Public Works and Police vehicles. A catalogue similar to the Ditch and Street Programs will be created. Director Gombac advised that, if approved, an inventory list of vehicles should be completed by November.

Alderman Beilke questioned if the Capital Improvement Guidelines will be a part of the budget. Administrator Vana responded that the guidelines are separate from the budget and are updated annually.

In regards to Consent Agenda Item P, Mayor Weaver inquired if any of the work is covered under warranty. Director Gombac responded in the negative and explained the necessary work to be performed.

15. **OLD BUSINESS**

There was none.

16. **CONSENT AGENDA**

Mayor Weaver reviewed the items on the Consent Agenda for the benefit of the viewing audience.

It was moved by Alderman Schauer and seconded by Alderman Marchese to approve by Omnibus Vote the following items on the Consent Agenda:

- A. ORDINANCE NO. O-10-13**      **AN ORDINANCE APPROVING A SPECIAL USE IN THE O OFFICE ZONING DISTRICT FOR THE ESTABLISHMENT OF A MEDICAL CLINIC (PZC 2013-01: 8190 CASS AVENUE, DR. KOHLI)**
  
- B. RESOLUTION NO. R-26-13**      **A RESOLUTION TO ADD QUANTITIES TO THE CURRENT CONTRACT FROM SUBURBAN CONCRETE INC. FOR APRON RESTORATIONS FOR THE 2013 DITCH MAINTENANCE IMPROVEMENT PROJECT IN AN AMOUNT NOT TO EXCEED \$50,000.00**
  
- C. RESOLUTION NO. R-27-13**      **A RESOLUTION ACCEPTING A PROPOSAL FROM RAINBOW TREE CARE SCIENTIFIC FOR THE TREEAGE INSECTICIDE, SUPPLIES, EQUIPMENT AND A CONTINGENCY AT A COST NOT TO EXCEED \$152,211.65 FOR THE EMERALD ASH BORER TREATMENT OF ASH TREES LOCATED WITHIN THE CITY PARKWAYS**
  
- D. RESOLUTION NO. R-28-13**      **A RESOLUTION ACCEPTING A PROPOSAL FROM EAST JORDAN IRON WORKS FOR THE EAST JORDAN FIRE HYDRANT REPAIR PARTS AS REQUIRED FOR A PERIOD OF MAY 1, 2013 THROUGH APRIL 30, 2014**



- E. RESOLUTION NO. R-29-13**      **A RESOLUTION ACCEPTING A PROPOSAL FROM UNDERGROUND PIPE AND VALVE INC. FOR THE CLOW EDDY FIRE HYDRANT REPAIR PARTS AS REQUIRED FOR A PERIOD OF MAY 1, 2013 THROUGH APRIL 30, 2014**
- F. RESOLUTION NO. R-30-13**      **A RESOLUTION ACCEPTING A PROPOSAL FROM HD SUPPLY WATERWORKS, INC. FOR THE US PIPE FIRE HYDRANT REPAIR PARTS FOR A PERIOD OF MAY 1, 2013 THROUGH APRIL 30, 2014**
- G. RESOLUTION NO. R-31-13**      **A RESOLUTION ACCEPTING A PROPOSAL FROM HD SUPPLY WATERWORKS INC. FOR THE MUELLER SUPER CENTURION FIRE HYDRANT REPAIR PARTS AS REQUIRED FOR A PERIOD OF MAY 1, 2013 THROUGH APRIL 30, 2014 LANDSCAPE RESTORATION SERVICES FOR A PERIOD OF MAY 1, 2013 THROUGH APRIL 30, 2014**
- H. RESOLUTION NO. R-32-13**      **A RESOLUTION ACCEPTING A PROPOSAL FROM HD SUPPLY WATERWORKS, INC. AND ZIEBELL WATER SERVICE PRODUCTS INC. FOR THE TRAVERSE CITY FIRE HYDRANT REPAIR PARTS AS REQUIRED FOR A PERIOD OF MAY 1, 2013 THROUGH APRIL 30, 2014**
- I. RESOLUTION NO. R-33-13**      **A RESOLUTION ACCEPTING A PROPOSAL FROM HD SUPPLY WATERWORKS, INC. AND ZIEBELL WATER SERVICE PRODUCTS INC. FOR THE WATEROUS PACER FIRE HYDRANT REPAIR PARTS AS**

**REQUIRED FOR A PERIOD OF MAY 1, 2013 THROUGH APRIL 30, 2014**

- J. RESOLUTION NO. R-34-13**      **A RESOLUTION ACCEPTING A PROPOSAL FROM HD SUPPLY, INC. FOR SMITH AND BLAIR STAINLESS STEEL WATER MAIN REPAIR CLAMPS FOR THE MAINTENANCE OF THE WATER SYSTEM FOR A PERIOD OF MAY 1, 2013 THROUGH APRIL 30, 2014**
  
- K. RESOLUTION NO. R-35-13**      **A RESOLUTION ACCEPTING A PROPOSAL FROM ZIEBELL WATER SERVICE FOR MUELLER BRAND BRASS FITTINGS FOR THE MAINTENANCE OF THE WATER SYSTEM FOR A PERIOD OF MAY 1, 2013 THROUGH APRIL 30, 2014**
  
- L. RESOLUTION NO. R-36-13**      **A RESOLUTION ACCEPTING A PROPOSAL FROM HD SUPPLY INC FOR VALVES, BUFFALO BOXES, (B-BOXES), AND CERTAIN COUPLINGS FOR THE MAINTENANCE OF THE WATER SYSTEM FOR A PERIOD OF MAY 1, 2013 THROUGH APRIL 30, 2014**
  
- M. RESOLUTION NO. R-37-13**      **A RESOLUTION ACCEPTING A PROPOSAL FROM WATER PRODUCTS INC. FOR HYMAX 2-12 INCH COUPLINGS FOR THE MAINTENANCE OF THE WATER SYSTEM FOR A PERIOD OF MAY 1, 2013 THROUGH APRIL 30, 2014**
  
- N. RESOLUTION NO. R-38-13**      **A RESOLUTION ACCEPTING A PROPOSAL FROM ZIEBELL INC. FOR MEGA LUG AND CUT IN SLEEVE ASSEMBLIES FOR THE MAINTENANCE OF THE WATER**

**SYSTEM FOR A PERIOD OF MAY 1,  
2013 THROUGH APRIL 30, 2014**

- O. RESOLUTION NO. R-39-13**      **A RESOLUTION ACCEPTING A PROPOSAL FROM UNDERGROUND PIPE AND VALVE FOR SOLID SLEEVES AND BUFFALO BOX ACCESSORIES FOR THE MAINTENANCE OF THE WATER SYSTEM FOR A PERIOD OF MAY 1, 2013 THROUGH APRIL 30, 2014**
- P. RESOLUTION NO. R-40-13**      **A RESOLUTION ACCEPTING A PROPOSAL FROM CHICAGO BRIDGE & IRON FOR THE URGENT REPAIRS OF THE WATER STANDPIPE AT 67<sup>TH</sup> & WILMETTE AVENUE AND THE WATER SPHEROID AT 8600 LEMONT ROAD IN AN AMOUNT NOT TO EXCEED \$83,900.00**
- Q. ORDINANCE NO. O-11-13**      **AN ORDINANCE OF THE CITY OF DARIEN, DUPAGE COUNTY, ILLINOIS, ASCERTAINING THE PREVAILING RATE OF WAGES FOR LABORERS, WORKMEN, AND MECHANICS EMPLOYED ON PUBLIC WORKS OF SAID CITY**
- R. A MOTION TO APPROVE AN ECONOMIC DEVELOPMENT MISSION STATEMENT**
- S. A MOTION TO APPROVE THE VEHICLE FLEET REPLACEMENT POLICY**

Roll Call:      Ayes: Beilke, Marchese, McIvor, Poteraske, Schauer, Seifert

                 Nays: None

                 Absent: Avci

                 Results: Ayes 6, Nays 0, Absent 1

**MOTION DULY CARRIED**

17. **NEW BUSINESS**

**A. CONSIDERATION OF A MOTION TO APPROVE AN ORDINANCE APPROVING THE 2013-2014 BUDGET**

It was moved by Alderman Schauer and seconded by Alderman Seifert to approve the ordinance as presented.

In regard to the Crest Basin, Alderman McIvor felt the owning agency should take responsibility for the expenditure. Director Gombac advised that, to date, he has not received a reply to his request for a meeting with the County to discuss the issue. Mayor Weaver agreed that the County should be held accountable. Alderman McIvor suggested DuPage County Board Members be invited to a City Council Meeting to discuss the condition of the basin. Alderman Marchese recommended area residents also be invited. Alderman Beilke and Administrator Vana noted that if the basin was properly maintained, planting of trees would not be necessary. In response to Mayor Weaver, Director Gombac advised the City has a copy of the County’s original plan. Mayor Weaver requested an invitation be extended for attendance at the April 15, 2013 City Council Meeting. It was agreed by all that the \$11,000 expenditure not be included in the budget.

Mayor Weaver recommended formal action be taken at the next City Council Meeting to determine if the 2013/2014 expenditure for District 61 crossing guards will be the last. Alderman Seifert expressed concern with the safety of the children during the 75<sup>th</sup> Street Construction Project. Administrator Vana advised that a motion of intent to not include crossing guards in the 2014/2015 budget will be placed on the April 15, 2013 City Council Meeting Agenda for consideration.

**ORDINANCE NO. O-12-13**

**AN ORDINANCE APPROVING THE 2013-2014 BUDGET**

Roll Call: Ayes: Beilke, Marchese, Poteraske, Schauer, Seifert

Nays: McIvor

Absent: Avci

Results: Ayes 5, Nays 1, Absent 1

**MOTION DULY CARRIED**

- B. CONSIDERATION OF A MOTION TO APPROVE A RESOLUTION TO ENTER INTO A CONTRACT AGREEMENT FOR THE 2013 STREET MAINTENANCE PROGRAM BETWEEN THE CITY OF DARIEN AND CENTRAL BLACKTOP COMPANY INC. IN AN AMOUNT NOT TO EXCEED \$1,451,270.53**

It was moved by Alderman Schauer and seconded by Alderman Beilke to approve the resolution as presented.

**RESOLUTION NO. R-41-13**

**A RESOLUTION TO ENTER INTO A CONTRACT AGREEMENT FOR THE 2013 STREET MAINTENANCE PROGRAM BETWEEN THE CITY OF DARIEN AND CENTRAL BLACKTOP COMPANY INC. IN AN AMOUNT NOT TO EXCEED \$1,451,270.53**

Roll Call:       Ayes:       Beilke, Marchese, McIvor, Poteraske, Schauer, Seifert

                      Nays:       None

                      Absent:     Avcı

Results: Ayes 6, Nays 0, Absent 1

**MOTION DULY CARRIED**

- C. CONSIDERATION OF A MOTION TO APPROVE A RESOLUTION AUTHORIZING THE MAYOR TO EXECUTE AN INTERGOVERNMENTAL AGREEMENT BETWEEN THE CITY OF DARIEN AND DARIEN PARK DISTRICT FOR ASPHALT PAVING WORK AT 802 PLAINFIELD ROAD**

It was moved by Alderman Marchese and seconded by Alderman Seifert to approve the resolution as presented.

**RESOLUTION NO. R-42-13**

**A RESOLUTION AUTHORIZING THE MAYOR TO EXECUTE AN INTERGOVERNMENTAL AGREEMENT BETWEEN THE CITY OF DARIEN AND DARIEN PARK DISTRICT FOR ASPHALT PAVING WORK AT 802 PLAINFIELD ROAD**

**City Council Meeting**

**April 1, 2013**

Roll Call: Ayes: Beilke, Marchese, McIvor, Poteraske, Schauer, Seifert

Nays: None

Absent: Avci

Results: Ayes 6, Nays 0, Absent 1

**MOTION DULY CARRIED**

18. **QUESTIONS, COMMENTS AND ANNOUNCEMENTS – GENERAL**

There were none.

19. **ADJOURNMENT**

There being no further business to come before the City Council, it was moved by Alderman McIvor and seconded by Alderman Schauer to adjourn the City Council meeting.

**VIA VOICE VOTE – MOTION DULY CARRIED**

The City Council meeting adjourned at 8:45 P.M.

---

Mayor

---

Deputy Clerk

All supporting documentation and report originals of these minutes are on file in the Office of the City Clerk under File Number 04-01-13.  
Minutes of 04-01-13 CCM

CITY OF DARIEN

EXPENDITURE APPROVAL LIST  
FOR CITY COUNCIL MEETING ON  
April 15, 2013

Approval is hereby given to have the City Treasurer of Darien, Illinois pay to the officers, employees, independent contractors, vendors, and other providers of goods and services in the indicated amounts as set forth.

A summary indicating the source of funds used to pay the above is as follows:

General Fund		<b>\$98,217.50</b>
Water Fund		<b>\$299,839.11</b>
Motor Fuel Tax Fund		<b>\$1,138.96</b>
Water Depreciation Fund		
Debt Service Fund		
Capital Improvement Fund		<b>\$1,211.78</b>
Special Service Area Tax Fund		
	<i>Subtotal:</i>	<b><u>\$ 400,407.35</u></b>
General Fund Payroll	04/04/13	\$ 217,433.75
Water Fund Payroll	04/04/13	\$ 13,863.23
	<i>Subtotal:</i>	<b><u>\$ 231,296.98</u></b>
<i>Total to be Approved by City Council:</i>		<b><u>\$ 631,704.33</u></b>

*Approvals:*

\_\_\_\_\_  
Kathleen Moesle Weaver, Mayor

\_\_\_\_\_  
JoAnne E. Ragona, City Clerk

\_\_\_\_\_  
Michael J. Coren, Treasurer

\_\_\_\_\_  
Bryon D. Vana, City Administrator

**CITY OF DARIEN**  
**Expenditure Journal**  
**General Fund**  
**Administration**  
**From 4/2/2013 Through 4/15/2013**

Vendor Name	Invoice Description	Acct Title	Dept Amount	Acct Code
AIS	CISCO CATALYST 48 & 24 PORT LAN LITE SWITCH	Consulting/Professional	3,890.00	4325
BEST QUALITY CLEANING, INC.	APRIL 2013 JANITORIAL SERVICE	Janitorial Service	1,182.00	4345
CHASE CARD SERVICES	PRINTER	Consulting/Professional	39.99	4325
EMERALD MARKETING INC.	MAY/JUNE 2013 NEIGHBORS OF DARIEN/CHAMBER DIRECTORY	Public Relations	3,145.27	4239
KATHY LYONS	REIMBURSEMENT FOR 2013 CITIZEN OF THE YEAR EXPENSES	Public Relations	738.87	4239
KING CAR WASH	CAR WASHES	Vehicle (Gas and Oil)	4.00	4273
LOGIN/IACP NET	ANNUAL FEE 4/11/13 TO 4/10/14	Contingency	800.00	4330
MUNICIPAL WEB SERVICES	FEBRUARY 2013 WEBSITE HOSTING	Consulting/Professional	708.00	4325
NICOR GAS	7422 S. CASS - ACCT 05-09-41-1000 3	Utilities (Elec,Gas,Wtr,Sewer)	130.32	4271
OFFICE DEPOT	SUPPLIES & TONER	Supplies - Office	63.06	4253
OFFICE DEPOT	SUPPLIES	Supplies - Office	43.49	4253
OFFICE DEPOT	SUPPLIES	Supplies - Office	13.09	4253
OFFICE DEPOT	TONER CARTRIDGES & DRUM	Supplies - Office	394.82	4253
OFFICE DEPOT	SUPPLIES & TONER	Supplies - Office	66.84	4253
VERIZON WIRELESS	CELL PHONES & POLICE AIRCARDS	Telephone	1,389.52	4267
WAREHOUSE DIRECT	SUPPLIES (TONER - HP5500)	Supplies - Office	187.23	4253
WAREHOUSE DIRECT	SUPPLIES (TONER - HP 5500)	Supplies - Office	264.55	4253
Total Administration			13,061.05	



**CITY OF DARIEN**  
**Expenditure Journal**  
**General Fund**  
**City Council**  
**From 4/2/2013 Through 4/15/2013**

<u>Vendor Name</u>	<u>Invoice Description</u>	<u>Acct Title</u>	<u>Dept Amount</u>	<u>Acct Code</u>
ACTION FLAG COMPANY	FOUR U.S. FLAGS	Public Relations	156.11	4239
ROSENTHAL, MURPHEY, COBLENTZ	JC CUTS	Liability Insurance	735.00	4219
ROSENTHAL, MURPHEY, COBLENTZ	MISCELLANEOUS	Liability Insurance	735.00	4219
ROSENTHAL, MURPHEY, COBLENTZ	COSTS ADVANCED	Liability Insurance	<u>126.87</u>	4219
		Total City Council	1,752.98	

**CITY OF DARIEN  
Expenditure Journal  
General Fund  
Community Development  
From 4/2/2013 Through 4/15/2013**

<u>Vendor Name</u>	<u>Invoice Description</u>	<u>Acct Title</u>	<u>Dept Amount</u>	<u>Acct Code</u>
CODE ENFORCEMENT REPRESENTATIV	CODE ENFORCEMENT ASSISTANCE - 201 PEONY	Const/Prof Reimbursable	60.00	4328
DON MORRIS ARCHITECTS P.C.	MARCH 2013 PLAN REVIEW & INSPECTIONS	Consulting/Professional	1,710.00	4325
DON MORRIS ARCHITECTS P.C.	MARCH 2013 PLAN REVIEW & INSPECTIONS	Const/Prof Reimbursable	2,772.33	4328
ELEVATOR INSPECTION SERVICE CO	ELEVATOR REINSPECTION - APRIL 2, 2013	Const/Prof Reimbursable	25.00	4328
JOSEPH ALGOZINE	MARCH 2013 ELECTRICAL INSPECTIONS	Consulting/Professional	375.00	4325
ROSENTHAL, MURPHEY, COBLENTZ	ZONING	Liability Insurance	<u>52.50</u>	4219
		Total Community Development	4,994.83	

**CITY OF DARIEN**  
**Expenditure Journal**  
**General Fund**  
**Public Works, Streets**  
**From 4/2/2013 Through 4/15/2013**

Vendor Name	Invoice Description	Acct Title	Dept Amount	Acct Code
ADVANTAGE CHEVROLET	REPAIR PARTS FOR PD #9 AND TRUCK #103	Maintenance - Vehicles	36.70	4229
AIR-RITE HEATING & COOLING	FURNACE REPAIR - 1041 S. FRONTAGE ROAD	Maintenance - Building	213.81	4223
ALL-STAR MAINTENANCE	SNOW CLEARING AT CITY HALL & POLICE DEPT.	Maintenance - Building	270.00	4223
CONSTELLATION NEW ENERGY, INC.	SW CORNER 75TH ST/PLAINFIELD - ACCT 0788318007	Street Light Oper & Maint.	1,039.20	4359
CONSTELLATION NEW ENERGY, INC.	STREET LIGHTS - ACCT 6753122017	Street Light Oper & Maint.	95.84	4359
CONSTELLATION NEW ENERGY, INC.	STREET LIGHTS - ACCT 2343005070	Street Light Oper & Maint.	8.65	4359
CULLIGAN	DRINKING WATER, CUPS & IRON FILTER RENTAL	Maintenance - Building	57.11	4223
FLEETPRIDE	PARTS FOR AIR BRAKES ON TRUCK #101	Maintenance - Vehicles	14.64	4229
FREEWAY FORD-STERLING TRUCK	REPAIR PARTS FOR TRUCK 101	Maintenance - Vehicles	48.91	4229
GRAINGER	DROP LIGHT FOR MECHANIC BAYS	Small Tools & Equipment	147.24	4259
HIGHWAY TECHNOLOGIES	40 TYPE I BARRICADES	Supplies - Other	1,859.60	4257
HOME DEPOT	SUPPLIES	Maintenance - Building	577.65	4223
HOME DEPOT	SUPPLIES	Supplies - Other	26.62	4257
HOME DEPOT	SUPPLIES	Forestry	189.05	4350
HOMER TREE CARE, INC.	2012/2013 TREE TRIMMING REMOVALS	Tree Trim/Removal	19,845.00	4375
LINDCO EQUIPMENT SALES, INC.	CUSHION VALVE UPGRADE FOR HYDRAULICS ON NEW TRUCK #112	Equipment	1,080.66	4815

**CITY OF DARIEN  
Expenditure Journal  
General Fund  
Public Works, Streets  
From 4/2/2013 Through 4/15/2013**

<u>Vendor Name</u>	<u>Invoice Description</u>	<u>Acct Title</u>	<u>Dept Amount</u>	<u>Acct Code</u>
LINDCO EQUIPMENT SALES, INC.	BODY FOR NEW TRUCK #112	Equipment	31,993.00	4815
O'HARA TRUE VALUE	SUPPLIES	Maintenance - Building	8.53	4223
O'HARA TRUE VALUE	SUPPLES	Maintenance - Building	20.47	4223
O'HARA TRUE VALUE	SUPPLIES	Maintenance - Building	3.98	4223
O'HARA TRUE VALUE	SUPPLIES	Maintenance - Equipment	0.96	4225
OCCUPATIONAL HEALTH CENTERS	RANDOM DRUG SCREEN	Liability Insurance	73.50	4219
PATTEN INDUSTRIES, INC.	GAS PEDAL FOR END LOADER #203	Maintenance - Equipment	274.21	4225
UNIQUE PRODUCTS & SERVICE CORP	JANITORIAL SUPPLIES	Maintenance - Building	98.96	4223
US GAS	OXYGEN & ACETYLENE CYLINDER RENTAL	Supplies - Other	28.00	4257
WILLOWBROOK FORD, INC.	REPAIR PARTS FOR TRUCK #501	Maintenance - Vehicles	323.85	4229
		Total Public Works, Streets	58,336.14	

**CITY OF DARIEN**  
**Expenditure Journal**  
**General Fund**  
**Police Department**  
**From 4/2/2013 Through 4/15/2013**

Vendor Name	Invoice Description	Acct Title	Dept Amount	Acct Code
ADVANTAGE CHEVROLET	REPAIR PARTS FOR PD #9 AND TRUCK #103	Maintenance - Vehicles	45.72	4229
ANTON HRUBY	UNIFORM ALLOWANCE	Uniforms	14.21	4269
CHASE CARD SERVICES	CHIEF BROWN MEMBERSHIP	Dues and Subscriptions	160.00	4213
CHASE CARD SERVICES	BLUE BOOK	Investigation and Equipment	24.95	4217
CHASE CARD SERVICES	DETECTIVE INTERNET SEARCHES	Investigation and Equipment	50.00	4217
CHASE CARD SERVICES	WINDOW SHIELDS	Investigation and Equipment	33.00	4217
CHASE CARD SERVICES	CLOCK	Investigation and Equipment	14.97	4217
CHASE CARD SERVICES	BATTERIES	Investigation and Equipment	62.45	4217
CHASE CARD SERVICES	BATTERIES	Investigation and Equipment	34.96	4217
CHASE CARD SERVICES	BATTERIES	Investigation and Equipment	59.82	4217
CHASE CARD SERVICES	POSTAGE FOR REPAIR	Postage/Mailings	11.74	4233
CHASE CARD SERVICES	POSTAGE FOR REPAIR	Postage/Mailings	17.14	4233
CHASE CARD SERVICES	SHIPPING FOR REPAIR	Postage/Mailings	10.54	4233
CHASE CARD SERVICES	DETECTIVE REGISTRY BOOKS	Supplies - Office	27.09	4253
CHASE CARD SERVICES	SUPPLIES	Supplies - Office	8.26	4253
CHASE CARD SERVICES	SUPPLIES & DVDS	Supplies - Office	205.31	4253
CHASE CARD SERVICES	FILES	Supplies - Office	28.17	4253
CHASE CARD SERVICES	TRAINING - COOPER & TOPEL	Training and Education	194.00	4263
CHASE CARD SERVICES	INTERNET	Telephone	101.90	4267
CHASE CARD SERVICES	INTERNET	Telephone	101.90	4267
COMCAST	CABLE BOXES	Telephone	2.13	4267
KALE UNIFORMS	MURPHY - UNIFORM ALLOWANCE	Uniforms	325.50	4269
KING CAR WASH	CAR WASHES	Maintenance - Vehicles	481.00	4229
LINDA S. PIECZYNSKI	PROSECUTION FEES	Liability Insurance	1,067.50	4219
MICHAEL LOREK	UNIFORM ALLOWANCE	Uniforms	359.97	4269
MOORE MEDICAL CORP.	FIRST AID SUPPLIES	Liability Insurance	539.15	4219
NORTHEAST MULTIREGIONAL TRNG	MILZAAO - BREATH ANALYSIS FOR ALCOHOL TRAINING	Training and Education	175.00	4263

**CITY OF DARIEN**  
**Expenditure Journal**  
**General Fund**  
**Police Department**  
**From 4/2/2013 Through 4/15/2013**

Vendor Name	Invoice Description	Acct Title	Dept Amount	Acct Code
NORTHEAST MULTIREGIONAL TRNG	PICCOLI & CHEAURE - ARREST, SEARCH & SEIZURE UPDATE	Training and Education	100.00	4263
NORTHEAST MULTIREGIONAL TRNG	JUMP - SEXTING: A PROACTIVE LAW ENFORCEMENT RESPONSE CLASS	Training and Education	150.00	4263
NORTHERN MICHIGAN K-9 INC.	NEW K-9	Equipment	12,500.00	4815
O'HARA TRUE VALUE	SUPPLIES	Maintenance - Vehicles	3.99	4229
PETTY CASH	PETTY CASH REIMBURSEMENT	Investigation and Equipment	16.93	4217
PETTY CASH	PETTY CASH REIMBURSEMENT	Maintenance - Vehicles	4.37	4229
PETTY CASH	PETTY CASH REIMBURSEMENT	Supplies - Office	91.86	4253
PETTY CASH	PETTY CASH REIMBURSEMENT	Travel/Meetings	124.28	4265
PUBLIC SAFETY DIRECT	CAMERA & RADAR REPAIRS - SQUADS 5, 7 & 18	Maintenance - Vehicles	95.00	4229
PUBLIC SAFETY DIRECT	LIGHTS/SIRENS UNITS 4, 14 & 18	Maintenance - Vehicles	380.00	4229
ROSENTHAL, MURPHEY, COBLENTZ STONE WHEEL, INC.	MAP - MISCELLANEOUS REPAIR PARTS FOR P.D. #19	Liability Insurance	577.50	4219
		Maintenance - Vehicles	79.03	4229
THE EMBLEM AUTHORITY	GOLD BADGE PATCH	Uniforms	50.00	4269
VERIZON WIRELESS	CELL PHONES & POLICE AIRCARDS	Telephone	798.21	4267
WILLOWBROOK FORD, INC.	REPAIR PARTS FOR SQUAD CARS	Maintenance - Vehicles	348.33	4229
WILLOWBROOK FORD, INC.	REPAIR PARTS FOR SQUADS	Maintenance - Vehicles	119.20	4229
		Total Police Department	19,595.08	

**CITY OF DARIEN**  
**Expenditure Journal**  
**General Fund**  
**Business District**  
**From 4/2/2013 Through 4/15/2013**

<u>Vendor Name</u>	<u>Invoice Description</u>	<u>Acct Title</u>	<u>Dept Amount</u>	<u>Acct Code</u>
ALLIED WASTE SERVICES #551	REFUSE REMOVAL - 7515 S. CASS, UNIT D - 04-01-13 TO 04-30-13	Utilities (Elec,Gas,Wtr,Sewer)	139.56	4271
NICOR GAS	7515 S. CASS, UNIT D	Utilities (Elec,Gas,Wtr,Sewer)	306.70	4271
NICOR GAS	7515 S. CASS, UNIT J - ACCT 43-44-83-6184 0	Utilities (Elec,Gas,Wtr,Sewer)	31.16	4271
		Total Business District	477.42	
		Total General Fund	98,217.50	

**CITY OF DARIEN**  
**Expenditure Journal**  
**Water Fund**  
**Public Works, Water**  
**From 4/2/2013 Through 4/15/2013**

<u>Vendor Name</u>	<u>Invoice Description</u>	<u>Acct Title</u>	<u>Dept Amount</u>	<u>Acct Code</u>
AIR-RITE HEATING & COOLING	FURNACE REPAIR - 1041 S. FRONTAGE ROAD	Maintenance - Building	213.81	4223
ASSOCIATED TECHNICAL SERVICES	LEAK DETECTION FOR MAIN BREAK ON CREEKSIDE	Leak Detection	652.50	4326
AWP CUSTOM UNIFORMS	UNIFORMS FOR DON & KEITH	Uniforms	258.00	4269
BEST QUALITY CLEANING, INC.	APRIL 2013 JANITORIAL SERVICE	Maintenance - Building	608.00	4223
CONSTELLATION NEW ENERGY, INC.	9S720 LEMONT - ACCT 4105091007	Utilities (Elec, Gas, Wtr, Sewer)	115.63	4271
CONSTELLATION NEW ENERGY, INC.	1220 PLAINFIELD - ACCT 0185101035	Utilities (Elec, Gas, Wtr, Sewer)	1,183.05	4271
CONSTELLATION NEW ENERGY, INC.	2101 W. 75TH STREET - ACCT 0269155053	Utilities (Elec, Gas, Wtr, Sewer)	47.72	4271
CONSTELLATION NEW ENERGY, INC.	LAKEVIEW & OAKLEY - ACCT 1389036061	Utilities (Elec, Gas, Wtr, Sewer)	247.47	4271
CONSTELLATION NEW ENERGY, INC.	87TH & RIDGE - ACCT 6149050015	Utilities (Elec, Gas, Wtr, Sewer)	186.38	4271
CONSTELLATION NEW ENERGY, INC.	18W736 MANNING - ACCT 0171115094	Utilities (Elec, Gas, Wtr, Sewer)	75.00	4271
CULLIGAN	DRINKING WATER, CUPS & IRON FILTER RENTAL	Maintenance - Building	57.11	4223
DUPAGE WATER COMMISSION	WATER COSTS	DuPage Water Commission	289,578.45	4340
ENVIRO-TEST & PERRY LABS	EPA REQUIRED WATER SAMPLES	Quality Control	255.00	4241
GENE'S TIRE SERVICE, INC.	REPAIR PARTS - #408	Maintenance - Equipment	45.90	4225
GENE'S TIRE SERVICE, INC.	TIRE - #407	Maintenance - Equipment	100.31	4225
HD SUPPLY WATERWORKS	FIRE HYDRANT WRENCHES & OUT OF SERVICE TAGS	Maintenance - Water System	192.21	4231



**CITY OF DARIEN**  
**Expenditure Journal**  
**Water Fund**  
**Public Works, Water**  
**From 4/2/2013 Through 4/15/2013**

Vendor Name	Invoice Description	Acct Title	Dept Amount	Acct Code
HD SUPPLY WATERWORKS	MUELLER HYDRANT BOTTOM SEAT O-RING PART A-44	Maintenance - Water System	14.33	4231
HOME DEPOT	SUPPLIES	Maintenance - Building	9.43	4223
HOME DEPOT	SUPPLIES	Maintenance - Water System	20.79	4231
MC CANN INDUSTRIES INC	DIAMONT BLADE FOR WALK BEHIND SAW	Maintenance - Water System	307.66	4231
NICOR GAS	1220 PLAINFIELD ROAD - ACCT 21-71-02-6494 2	Utilities (Elec, Gas, Wtr, Sewer)	25.32	4271
O'HARA TRUE VALUE	SUPPLIES	Maintenance - Building	8.54	4223
O'HARA TRUE VALUE	SUPPLIES	Maintenance - Equipment	13.28	4225
SUBURBAN LABORATORIES	US EPA UCMR3 WATER SAMPLING	Quality Control	1,150.00	4241
US GAS	OXYGEN & ACETYLENE CYLINDER RENTAL	Maintenance - Water System	28.00	4231
VERIZON WIRELESS	CELL PHONES & POLICE AIRCARDS	Telephone	245.22	4267
WATER RESOURCES, INC.	5/8 x 3/4 WATER METERS	Water Meter Purchases	4,200.00	4880
			299,839.11	
			299,839.11	

**CITY OF DARIEN**  
**Expenditure Journal**  
**Motor Fuel Tax**  
**MFT Expenses**  
**From 4/2/2013 Through 4/15/2013**

<u>Vendor Name</u>	<u>Invoice Description</u>	<u>Acct Title</u>	<u>Dept Amount</u>	<u>Acct Code</u>
KIEFT BROS., INC.	6-INCH RING FOR SEWER REPAIR ON WOODMERE	Supplies - Other	19.00	4257
QUARRY MATERIALS	COLD PATCH	Road Material	<u>1,119.96</u>	4245
		Total MFT Expenses	<u>1,138.96</u>	
		Total Motor Fuel Tax	1,138.96	

**CITY OF DARIEN**  
**Expenditure Journal**  
**Capital Improvement Fund**  
**Capital Fund Expenditures**  
**From 4/2/2013 Through 4/15/2013**

<u>Vendor Name</u>	<u>Invoice Description</u>	<u>Acct Title</u>	<u>Dept Amount</u>	<u>Acct Code</u>
ANDROMEDA TECHNOLOGY SOLUTIONS	CAMERA SYSTEM AT 1710 PLAINFIELD ROAD	Equipment	1,211.78	4815
		Total Capital Fund Expenditures	1,211.78	
		Total Capital Improvement Fund	1,211.78	
Report Total			400,407.35	

04/24/13

\$1,186.19

\$0.00

\$237.00

CHASE

Account number: [REDACTED]

\$

1186.19

Make your check payable to:  
Chase Card Services.  
Please write amount enclosed.  
New address or e-mail? Print on back.

19076 BEK Z 09213 C  
BRYON VANA  
CITY OF DARIEN  
1702 PLAINFIELD RD  
DARIEN IL 60561-5044



CARDMEMBER SERVICE  
PO BOX 15153  
WILMINGTON DE 19886-5153



[REDACTED] 811

### BUSINESS CARD STATEMENT

Customer Service  
1-800-275-0863

Additional contact  
information on back →

#### ACCOUNT SUMMARY

Account Number: [REDACTED]

Previous Balance	\$1,384.80
Payment, Credits	-\$1,384.80
Purchases	+\$1,186.19
Cash Advances	\$0.00
Balance Transfers	\$0.00
Fees Charged	\$0.00
Interest Charged	\$0.00
<b>New Balance</b>	<b>\$1,186.19</b>

#### PAYMENT INFORMATION

New Balance	\$1,186.19
Payment Due Date	04/24/13
Minimum Payment Due	\$237.00

**Late Payment Warning:** If we do not receive your minimum payment by the due date, you may have to pay up to a \$39 late fee.

**Minimum Payment Warning:** Enroll in Auto-Pay and avoid missing a payment. To enroll, call the number on the back of your card or go to the web site listed above.

Opening/Closing Date	03/03/13 - 04/02/13
Total Credit Line	\$100,000
Available Credit	\$98,813
Cash Access Line	\$20,000
Available for Cash	\$20,000

#### FLEXIBLE REWARDS SUMMARY

Previous points balance	5,948
Points earned on purchases this period	1,187
<b>New total points balance</b>	<b>7,135</b>

Every time you use your Chase Business card with Flexible Rewards Select, you are on your way to earning great rewards. You earn 1 point per \$1 spent on all purchases and there's no cap on how many points you can earn and points never expire. Add employees and earn rewards even faster! You can redeem your points for airline tickets, gift certificates to leading merchants, top quality merchandise or cash. Check out the entire rewards collection and redeem your points online at [www.chase.com/businesscard](http://www.chase.com/businesscard).

#### ACCOUNT ACTIVITY

Date of Transaction	Merchant Name or Transaction Description	\$ Amount
03/17	Payment Thank You Image Check BRYON VANA TRANSACTIONS THIS CYCLE [REDACTED] -\$1,384.80 INCLUDING PAYMENTS RECEIVED	-1,384.80
03/21	OFFICE DEPOT #340 DOWNERS GROVE IL DANIEL GOMBAC TRANSACTIONS THIS CYCLE [REDACTED] \$39.99	39.99
03/08	MAP*MACNEIL AUTOMOTIVE 800-441-6287 IL 01-40-4217 Window Shields	33.00
03/11	WAL-MART #2215 DARIEN IL 01-40-4217 Circle for #318	14.97
03/12	BEST BUY MHT 00003160 DOWNERS GROVE IL 01-40-4217 Batteries	62.45
03/21	BEST BUY MHT 00003160 DOWNERS GROVE IL 01-40-4217 Batteries	64.06
03/28	THE HOME DEPOT 1905 DARIEN IL 01-40-4217 Batteries SARAH FALCO TRANSACTIONS THIS CYCLE [REDACTED] \$205.20	59.82
03/01	USPS.COM CLICK66100611 800-3447779 DC 01-40-4233 Postage for repair	11.74
03/02	COMCAST CHICAGO 800-COMCAST IL 01-40-4267 Internet	101.90
03/04	USPS.COM CLICK66100611 800-3447779 DC 01-40-4233 Postage for repair	17.14
03/04	LEXISNEXIS RISK MGT 888-332-8244 FL 01-40-4217 Detective internet search	50.00
03/08	OFFICE DEPOT #1105 800-463-3768 IL 01-40-4253 Detective registry books	27.09
03/12	OFFICE DEPOT #1105 800-463-3768 IL 01-40-4253 Pens	8.26
03/22	OFFICE DEPOT #1105 800-463-3768 IL 01-40-4253 Supplies & DVD's	205.31
03/28	COMCAST CHICAGO 800-COMCAST IL 01-40-4267 Internet	101.90

**ACCOUNT ACTIVITY (CONTINUED)**

Date of Transaction	Merchant Name or Transaction Description	\$ Amount
03/27	USPS.COM CLICK66100611 800-3447779 DC 01-40-4233 Shipping Return	10.54
03/27	BLUE BOOK 603-626-1500 NH 01-40-4217 Blue Book	24.95
03/28	OFFICE DEPOT #1105 800-463-3768 IL 01-40-4253 Files	28.17
03/28	WINNINGMIND 4032795954 AB 01-40-4263 Comp & Typd Trainings	194.00
03/28	POLICE EXECUTIVE RESEARCH 202-4667820 DC 01-40-4213 Child Membership	160.00
	CAROL KOPTA	
	TRANSACTIONS THIS CYCLE (03/03/13) \$941.00	

2013 Totals Year-to-Date	
Total fees charged in 2013	\$0.00
Total interest charged in 2013	\$0.00

Year-to-date totals reflect all charges minus any refunds applied to your account.

**INTEREST CHARGES**

Your Annual Percentage Rate (APR) is the annual interest rate on your account.

Balance Type	Annual Percentage Rate (APR)	Balance Subject To Interest Rate	Interest Charges
<b>PURCHASES</b>			
Purchases	13.24% (v)	-0-	-0-
<b>CASH ADVANCES</b>			
Cash Advances	19.24% (v)	-0-	-0-
<b>BALANCE TRANSFERS</b>			
Balance Transfer	13.24% (v)	-0-	-0-

(v) = Variable Rate

31 Days In Billing Period

Please see Information About Your Account section for the Calculation of Balance Subject to Interest Rate, Annual Renewal Notice, How to Avoid Interest on Purchases, and other important information, as applicable.

**CITY OF DARIEN**  
**REVENUE AND EXPENDITURE REPORT SUMMARY**  
**March 31, 2013**

**GENERAL FUND - (01)**

	Current Month <u>Actual</u>	Year To Date <u>Actual</u>	Total <u>Budget</u>
Revenue	\$ 920,488	\$ 12,518,426	\$ 12,694,067
Expenditures	\$ 657,543	\$ 9,314,354	\$ 10,834,371

Audited 5/1/12 Opening Fund Balance: \$ 4,108,526  
Transfer to Capital Fund \$ (2,800,000)  
Current Fund Balance: \$ 4,512,598

**WATER FUND - (02)**

	Current Month <u>Actual</u>	Year To Date <u>Actual</u>	Total <u>Budget</u>
Revenue	\$ 3,819	\$ 4,896,611	\$ 5,324,219
Expenditures	\$ 386,574	\$ 5,186,758	\$ 5,730,642

\*Audited 5/1/12 Cash Balance \$ 878,155  
Current Cash Balance: \$ 588,008

**MOTOR FUEL TAX FUND - (03)**

	Current Month <u>Actual</u>	Year To Date <u>Actual</u>	Total <u>Budget</u>
Revenue	\$ 38,151	\$ 598,129	\$ 575,000
Expenditures	\$ 138,865	\$ 495,034	\$ 536,860

Audited 5/1/12 Opening Fund Balance: \$ 209,824  
Current Fund Balance: \$ 312,919

**WATER DEPRECIATION FUND (12)**

	Current Month <u>Actual</u>	Year To Date <u>Actual</u>	Total <u>Budget</u>
Revenue	\$ 919	\$ 508,031	\$ 505,000
Expenditures	\$ -	\$ 21,907	\$ 163,500

\*Audited 5/1/12 Cash Balance \$ 276,274  
Current Cash Balance: \$ 762,398

**CAPITAL IMPROVEMENT FUND (25)**

	Current Month <u>Actual</u>	Year To Date <u>Actual</u>	Total <u>Budget</u>
Revenue	\$ 4,842	\$ 5,087,085	\$ 4,806,194
Expenditures	\$ 9,887	\$ 2,929,094	\$ 3,207,744

Audited 5/1/12 Opening Fund Balance: \$ 1,864,708  
Current Fund Balance: \$ 4,022,699

**CAPITAL PROJECTS DEBT SERVICE FUND (35)**

	Current Month <u>Actual</u>	Year To Date <u>Actual</u>	Total <u>Budget</u>
Revenue	\$ 9	\$ 498,021	\$ 494,300
Expenditures	\$ -	\$ 494,375	\$ 496,802

Audited 5/1/12 Opening Fund Balance: \$ 4,207  
Current Fund Balance: \$ 7,854

	Current Actual Year to Date	Current Budgeted F.Y.E. '13	Prior Year Actual Through March 12
Property Tax Collections	\$ 2,340,611	\$ 2,319,044	\$ 2,332,310
Sales Tax Collections	\$ 4,528,057	\$ 4,900,000	\$ 4,537,123

\* Audited cash balance less Accounts Payable at year end

**CITY OF DARIEN**  
**Statement of Revenues and Expenditures - Revenue**  
**Revenue**  
**General Fund**  
**From 3/1/2013 Through 3/31/2013**

		Current Period Actual	Current Period Budget	Current Year Actual	YTD Budget	Total Budget	Total Budget Variance	Percent Total Budget Remaining
<b>Revenue</b>								
<b>Taxes</b>								
Real Estate Taxes - Current	3110	0.00	0.00	1,636,277.48	1,617,850.00	1,617,850.00	(18,427.48)	(1.13)%
Road and Bridge Tax	3120	33.77	32,500.00	193,599.64	125,000.00	185,000.00	(8,599.64)	(4.64)%
Municipal Utility Tax	3130	113,960.45	93,416.67	900,219.43	1,027,583.37	1,121,000.00	220,780.57	19.69%
Amusement Tax	3140	6,045.66	8,333.33	75,187.98	91,666.63	100,000.00	24,812.02	24.81%
Hotel/Motel Tax	3150	0.00	2,583.33	39,131.62	28,416.63	31,000.00	(8,131.62)	(26.23)%
Personal Property Tax	3425	266.41	416.67	4,376.82	4,583.37	5,000.00	623.18	12.46%
<b>Total Taxes</b>		<b>120,306.29</b>	<b>137,250.00</b>	<b>2,848,792.97</b>	<b>2,895,100.00</b>	<b>3,059,850.00</b>	<b>(211,057.03)</b>	<b>6.90%</b>
<b>License, Permits, Fees</b>								
Business Licenses	3210	125.00	0.00	9,560.00	0.00	40,000.00	30,440.00	76.10%
Liquor License	3212	50.00	0.00	53,600.00	50,000.00	50,000.00	(3,600.00)	(7.20)%
Contractor Licenses	3214	1,390.00	1,000.00	14,040.00	11,000.00	12,000.00	(2,040.00)	(17.00)%
Court Fines	3216	15,394.07	12,500.00	138,927.86	137,500.00	150,000.00	11,072.14	7.38%
Towing Fees	3217	8,500.00	3,333.33	93,300.00	36,666.63	40,000.00	(53,300.00)	(133.25)%
Ordinance Fines	3230	1,710.00	1,250.00	23,591.00	13,750.00	15,000.00	(8,591.00)	(57.27)%
Building Permits and Fees	3240	4,220.00	2,000.00	137,748.00	43,000.00	45,000.00	(92,748.00)	(206.10)%
Telecommunication Taxes	3242	75,325.13	80,416.67	851,691.17	884,583.37	965,000.00	113,308.83	11.74%
Cable T.V. Franchise Fee	3244	0.00	26,666.67	344,506.10	293,333.37	320,000.00	(24,506.10)	(7.65)%
PEG - Fees - AT&T	3245	0.00	0.00	28,653.93	0.00	0.00	(28,653.93)	0.00%
NICOR Franchise Fee	3246	0.00	3,166.67	29,975.49	34,833.37	38,000.00	8,024.51	21.11%
Public Hearing Fees	3250	671.55	416.67	5,159.36	4,583.37	5,000.00	(159.36)	(3.18)%
Elevator Inspections	3255	2,200.00	333.33	5,232.25	3,666.63	4,000.00	(1,232.25)	(30.80)%
Public Improvement Permit Fee	3260	0.00	0.00	3,790.00	0.00	0.00	(3,790.00)	0.00%
Engineering/Prof Fee Reimb	3265	2,651.81	1,666.67	51,306.28	18,333.37	20,000.00	(31,306.28)	(156.53)%
D.U.I. Technology Fines	3267	1,785.00	333.33	9,226.93	3,666.63	4,000.00	(5,226.93)	(130.67)%
Police Special Service	3268	2,762.50	8,333.33	126,850.64	91,666.63	100,000.00	(26,850.64)	(26.85)%
Stormwater Management Fees	3270	50.00	0.00	1,368.40	0.00	0.00	(1,368.40)	0.00%
<b>Total License, Permits, Fees</b>		<b>116,835.06</b>	<b>141,416.67</b>	<b>1,928,527.41</b>	<b>1,626,583.37</b>	<b>1,808,000.00</b>	<b>120,527.41</b>	<b>(6.67)%</b>

**CITY OF DARIEN**  
**Statement of Revenues and Expenditures - Revenue**  
**Revenue**  
**General Fund**  
**From 3/1/2013 Through 3/31/2013**

		Current Period Actual	Current Period Budget	Current Year Actual	YTD Budget	Total Budget	Total Budget Variance	Percent Total Budget Remaining
Charges for Services								
Inspections/Tap on/Permits	3320	25.00	0.00	2,500.00	0.00	0.00	(2,500.00)	0.00%
Total Charges for Services		25.00	0.00	2,500.00	0.00	0.00	2,500.00	0.00%
Intergovernmental								
State Income Tax	3410	114,507.26	143,559.00	1,940,638.83	1,579,149.00	1,722,708.00	(217,930.83)	(12.65)%
Local Use Tax	3420	42,834.61	27,975.58	322,113.97	307,731.38	335,707.00	13,593.03	4.04%
Sales Taxes	3430	451,400.50	408,333.33	4,528,056.93	4,491,666.63	4,900,000.00	371,943.07	7.59%
Total Intergovernmental		608,742.37	579,867.91	6,790,809.73	6,378,547.01	6,958,415.00	(167,605.27)	2.41%
Other Revenue								
Interest Income	3510	2,738.30	1,916.67	17,587.78	21,083.37	23,000.00	5,412.22	23.53%
Gain/Loss on Investment	3515	0.70	0.00	4,308.89	0.00	0.00	(4,308.89)	0.00%
Water Share Expense	3520	20,833.34	20,833.33	229,166.74	229,166.63	250,000.00	20,833.26	8.33%
Police Report/Prints	3534	635.00	375.00	5,170.00	4,125.00	4,500.00	(670.00)	(14.88)%
Reimbursement-Rear Yard Drain	3541	0.00	0.00	2,638.65	0.00	0.00	(2,638.65)	0.00%
Grants	3560	0.00	0.00	1,004.91	0.00	0.00	(1,004.91)	0.00%
Rents	3561	28,736.87	19,941.83	217,499.98	219,360.13	239,302.00	21,802.02	9.11%
Other Reimbursements	3562	5,298.80	5,416.67	105,295.03	59,583.37	65,000.00	(40,295.03)	(61.99)%
Residential Concrete Reimb	3563	0.00	0.00	55,138.67	0.00	0.00	(55,138.67)	0.00%
Mail Box Reimbursement Program	3569	0.00	0.00	2,224.73	0.00	0.00	(2,224.73)	0.00%
Impact Fee Revenue	3570	0.00	0.00	5,263.00	0.00	0.00	(5,263.00)	0.00%
Sales of Wood Chips	3572	0.00	0.00	3,890.00	0.00	0.00	(3,890.00)	0.00%
Sale of Property	3573	0.00	0.00	1,994.50	0.00	0.00	(1,994.50)	0.00%
Sale of Equipment	3575	1,420.00	2,083.33	25,877.82	22,916.63	25,000.00	(877.82)	(3.51)%
Miscellaneous Revenue	3580	655.15	8,750.00	38,982.49	96,250.00	105,000.00	66,017.51	62.87%
Transfer from Other Funds	3612	0.00	0.00	92,860.00	0.00	0.00	(92,860.00)	0.00%
Total Other Revenue		60,318.16	59,316.83	808,903.19	652,485.13	711,802.00	97,101.19	(13.64)%
Total Revenue		906,226.88	917,851.41	12,379,533.30	11,552,715.51	12,538,067.00	(158,533.70)	1.26%



**CITY OF DARIEN**  
**Statement of Revenues and Expenditures - Revenue**  
**Revenue**  
**Water Fund**  
**From 3/1/2013 Through 3/31/2013**

		Current Period Actual	Current Period Budget	Current Year Actual	YTD Budget	Total Budget	Total Budget Variance	Percent Total Budget Remaining
<b>Revenue</b>								
<b>Charges for Services</b>								
Water Sales	3310	0.00	0.00	4,841,492.55	4,500,000.00	5,308,219.00	466,726.45	8.79%
Inspections/Tap on/Permits	3320	2,397.42	333.33	23,805.03	3,666.63	4,000.00	(19,805.03)	(495.12)%
Sale of Meters	3325	275.00	291.67	4,628.00	3,208.37	3,500.00	(1,128.00)	(32.22)%
Other Water Sales	3390	0.00	375.00	8,054.60	4,125.00	4,500.00	(3,554.60)	(78.99)%
<b>Total Charges for Services</b>		<u>2,672.42</u>	<u>1,000.00</u>	<u>4,877,980.18</u>	<u>4,511,000.00</u>	<u>5,320,219.00</u>	<u>(442,238.82)</u>	<u>8.31%</u>
<b>Other Revenue</b>								
Interest Income	3510	1,147.01	333.33	9,479.25	3,666.63	4,000.00	(5,479.25)	(136.98)%
Other Reimbursements	3562	0.00	0.00	9,151.20	0.00	0.00	(9,151.20)	0.00%
<b>Total Other Revenue</b>		<u>1,147.01</u>	<u>333.33</u>	<u>18,630.45</u>	<u>3,666.63</u>	<u>4,000.00</u>	<u>14,630.45</u>	<u>(365.76)%</u>
<b>Total Revenue</b>		<u>3,819.43</u>	<u>1,333.33</u>	<u>4,896,610.63</u>	<u>4,514,666.63</u>	<u>5,324,219.00</u>	<u>(427,608.37)</u>	<u>8.03%</u>

**CITY OF DARIEN**  
**Statement of Revenues and Expenditures - Revenue**  
**Revenue**  
**Motor Fuel Tax**  
**From 3/1/2013 Through 3/31/2013**

	Current Period Actual	Current Period Budget	Current Year Actual	YTD Budget	Total Budget	Total Budget Variance	Percent Total Budget Remaining
Revenue							
Intergovernmental							
MFT Allotment	3440 37,703.92	47,916.67	486,200.39	527,083.37	575,000.00	88,799.61	15.44%
Total Intergovernmental	37,703.92	47,916.67	486,200.39	527,083.37	575,000.00	(88,799.61)	15.44%
Other Revenue							
Interest Income	3510 447.01	0.00	3,586.58	0.00	0.00	(3,586.58)	0.00%
Grants	3560 0.00	0.00	102,552.00	0.00	0.00	(102,552.00)	0.00%
Miscellaneous Revenue	3580 0.00	0.00	5,790.00	0.00	0.00	(5,790.00)	0.00%
Total Other Revenue	447.01	0.00	111,928.58	0.00	0.00	111,928.58	0.00%
Total Revenue	38,150.93	47,916.67	598,128.97	527,083.37	575,000.00	23,128.97	(4.02)%

**CITY OF DARIEN**  
**Statement of Revenues and Expenditures - Revenue**  
**Revenue**  
**Impact Fee Agency Fund**  
**From 3/1/2013 Through 3/31/2013**

	Current Period Actual	Current Period Budget	Current Year Actual	YTD Budget	Total Budget	Total Budget Variance	Percent Total Budget Remaining
Revenue							
Other Revenue							
Interest Income	3510 15.86	0.00	174.06	0.00	0.00	(174.06)	0.00%
Total Other Revenue	15.86	0.00	174.06	0.00	0.00	174.06	0.00%
Total Revenue	15.86	0.00	174.06	0.00	0.00	174.06	0.00%

**CITY OF DARIEN**  
**Statement of Revenues and Expenditures - Revenue**  
**Revenue**  
**Special Service Area Tax Fund**  
**From 3/1/2013 Through 3/31/2013**

	Current Period Actual	Current Period Budget	Current Year Actual	YTD Budget	Total Budget	Total Budget Variance	Percent Total Budget Remaining
Revenue							
Taxes							
Real Estate Taxes - Current	3110	0.00	5,031.12	2,500.00	5,000.00	(31.12)	(0.62)%
Total Taxes	0.00	0.00	5,031.12	2,500.00	5,000.00	31.12	(0.62)%
Other Revenue							
Interest Income	3510	10.72	137.70	0.00	0.00	(137.70)	0.00%
Total Other Revenue	10.72	0.00	137.70	0.00	0.00	137.70	0.00%
Total Revenue	10.72	0.00	5,168.82	2,500.00	5,000.00	168.82	(3.38)%

**CITY OF DARIEN**  
**Statement of Revenues and Expenditures - Revenue**  
**Revenue**  
**Drug Forfeiture Fund**  
**From 3/1/2013 Through 3/31/2013**

	Current Period Actual	Current Period Budget	Current Year Actual	YTD Budget	Total Budget	Total Budget Variance	Percent Total Budget Remaining
Revenue							
Other Revenue							
Interest Income	3510 6.30	0.00	93.21	0.00	0.00	(93.21)	0.00%
Total Other Revenue	6.30	0.00	93.21	0.00	0.00	93.21	0.00%
Total Revenue	6.30	0.00	93.21	0.00	0.00	93.21	0.00%

**CITY OF DARIEN**  
**Statement of Revenues and Expenditures - Revenue**  
**Revenue**  
**Water Depreciation Fund**  
**From 3/1/2013 Through 3/31/2013**

	Current Period Actual	Current Period Budget	Current Year Actual	YTD Budget	Total Budget	Total Budget Variance	Percent Total Budget Remaining
Revenue							
Other Revenue							
Interest Income	3510 918.43	416.67	8,020.44	4,583.37	5,000.00	(3,020.44)	(60.40)%
Gain/Loss on Investment	3515 0.15	0.00	10.33	0.00	0.00	(10.33)	0.00%
Transfer from Water Fund	3610 0.00	0.00	500,000.00	500,000.00	500,000.00	0.00	0.00%
Total Other Revenue	<u>918.58</u>	<u>416.67</u>	<u>508,030.77</u>	<u>504,583.37</u>	<u>505,000.00</u>	<u>3,030.77</u>	<u>(0.60)%</u>
Total Revenue	918.58	416.67	508,030.77	504,583.37	505,000.00	3,030.77	(0.60)%

**CITY OF DARIEN**  
**Statement of Revenues and Expenditures - Revenue**  
**Revenue**  
**Darien Area Dispatch Center**  
**From 3/1/2013 Through 3/31/2013**

	Current Period Actual	Current Period Budget	Current Year Actual	YTD Budget	Total Budget	Total Budget Variance	Percent Total Budget Remaining
Revenue							
Other Revenue							
Interest Income	3510 375.62	0.00	5,063.85	0.00	0.00	(5,063.85)	0.00%
Total Other Revenue	<u>375.62</u>	<u>0.00</u>	<u>5,063.85</u>	<u>0.00</u>	<u>0.00</u>	<u>5,063.85</u>	<u>0.00%</u>
Total Revenue	375.62	0.00	5,063.85	0.00	0.00	5,063.85	0.00%

**CITY OF DARIEN**  
**Statement of Revenues and Expenditures - Revenue**  
**Revenue**  
**Drug Seizures Fund**  
**From 3/1/2013 Through 3/31/2013**

	Current Period Actual	Current Period Budget	Current Year Actual	YTD Budget	Total Budget	Total Budget Variance	Percent Total Budget Remaining
Revenue							
Other Revenue							
Interest Income	3510 27.65	0.00	300.54	0.00	0.00	(300.54)	0.00%
Total Other Revenue	27.65	0.00	300.54	0.00	0.00	300.54	0.00%
Total Revenue	27.65	0.00	300.54	0.00	0.00	300.54	0.00%



**CITY OF DARIEN**  
**Statement of Revenues and Expenditures - Revenue**  
**Revenue**  
**Capital Improvement Fund**  
**From 3/1/2013 Through 3/31/2013**

	Current Period Actual	Current Period Budget	Current Year Actual	YTD Budget	Total Budget	Total Budget Variance	Percent Total Budget Remaining
Revenue							
Taxes							
Real Estate Taxes - Current	3110 0.00	101,000.00	203,096.86	202,194.00	202,194.00	(902.86)	(0.44)%
Total Taxes	0.00	101,000.00	203,096.86	202,194.00	202,194.00	902.86	(0.45)%
Other Revenue							
Interest Income	3510 4,841.80	333.33	50,877.26	3,666.63	4,000.00	(46,877.26)	(1,171.93)%
Street Recon Prog - Reimb	3550 0.00	0.00	83,110.64	0.00	0.00	(83,110.64)	0.00%
Sale of Property	3573 0.00	0.00	1,950,000.00	1,800,000.00	1,800,000.00	(150,000.00)	(8.33)%
Transfer from Other Funds	3612 0.00	0.00	2,800,000.00	2,800,000.00	2,800,000.00	0.00	0.00%
Total Other Revenue	4,841.80	333.33	4,883,987.90	4,603,666.63	4,604,000.00	279,987.90	(6.08)%
Total Revenue	4,841.80	101,333.33	5,087,084.76	4,805,860.63	4,806,194.00	280,890.76	(5.84)%

**CITY OF DARIEN**  
**Statement of Revenues and Expenditures - Revenue**  
**Revenue**  
**Debt Service Fund**  
**From 3/1/2013 Through 3/31/2013**

	Current Period Actual	Current Period Budget	Current Year Actual	YTD Budget	Total Budget	Total Budget Variance	Percent Total Budget Remaining
Revenue							
Taxes							
Real Estate Taxes - Current	3110 0.00	0.00	496,205.89	250,000.00	494,000.00	(2,205.89)	(0.44)%
Total Taxes	0.00	0.00	496,205.89	250,000.00	494,000.00	2,205.89	(0.45)%
Other Revenue							
Interest Income	3510 9.45	25.00	1,815.56	275.00	300.00	(1,515.56)	(505.18)%
Total Other Revenue	9.45	25.00	1,815.56	275.00	300.00	1,515.56	(505.19)%
Total Revenue	9.45	25.00	498,021.45	250,275.00	494,300.00	3,721.45	(0.75)%

**CITY OF DARIEN**  
**Statement of Revenues and Expenditures - Revenue**  
**Business District**  
**General Fund**  
**From 3/1/2013 Through 3/31/2013**

	Current Period Actual	Current Period Budget	Current Year Actual	YTD Budget	Total Budget	Total Budget Variance	Percent Total Budget Remaining
Revenue							
Other Revenue							
Rents	3561 13,300.00	11,916.67	131,795.63	131,083.37	143,000.00	11,204.37	7.83%
Maintenance - Reimbursable	3567 318.00	1,083.33	3,460.78	11,916.63	13,000.00	9,539.22	73.37%
Operations Revenue	3576 643.51	0.00	3,636.43	0.00	0.00	(3,636.43)	0.00%
Total Other Revenue	<u>14,261.51</u>	<u>13,000.00</u>	<u>138,892.84</u>	<u>143,000.00</u>	<u>156,000.00</u>	<u>(17,107.16)</u>	<u>10.97%</u>
Total Revenue	14,261.51	13,000.00	138,892.84	143,000.00	156,000.00	(17,107.16)	10.97%

**CITY OF DARIEN**  
**Statement of Revenues and Expenditures - Expenditures**  
**General Fund**  
**Administration**  
**From 3/1/2013 Through 3/31/2013**

		Current Period Actual	Current Period Budget	Current Year Actual	YTD Budget	Total Budget	Total Budget Variance	Percent Total Budget Remaining
<b>Expenditures</b>								
<b>Salaries</b>								
Salaries	4010	34,192.33	34,885.00	423,179.09	418,615.00	453,500.00	30,320.91	6.68%
Overtime	4030	0.00	0.00	83.58	2,000.00	2,000.00	1,916.42	95.82%
<b>Total Salaries</b>		<u>34,192.33</u>	<u>34,885.00</u>	<u>423,262.67</u>	<u>420,615.00</u>	<u>455,500.00</u>	<u>32,237.33</u>	<u>7.08%</u>
<b>Benefits</b>								
Social Security	4110	2,134.57	1,927.00	23,014.79	23,125.00	25,056.00	2,041.21	8.14%
Medicare	4111	499.20	510.00	6,191.64	6,120.00	6,634.00	442.36	6.66%
I.M.R.F.	4115	4,504.77	4,448.00	54,896.08	53,376.00	57,828.00	2,931.92	5.07%
Medical/Life Insurance	4120	5,033.30	5,057.50	55,125.24	55,632.50	60,690.00	5,564.76	9.16%
Supplemental Pensions	4135	1,908.14	1,998.67	22,897.68	21,985.37	23,984.00	1,086.32	4.52%
<b>Total Benefits</b>		<u>14,079.98</u>	<u>13,941.17</u>	<u>162,125.43</u>	<u>160,238.87</u>	<u>174,192.00</u>	<u>12,066.57</u>	<u>6.93%</u>
<b>Materials and Supplies</b>								
Dues and Subscriptions	4213	0.00	200.00	2,682.90	2,200.00	2,400.00	(282.90)	(11.78)%
Liability Insurance	4219	400.00	2,343.33	29,442.74	45,776.63	48,120.00	18,677.26	38.81%
Legal Notices	4221	311.55	666.67	5,090.47	7,333.37	8,000.00	2,909.53	36.36%
Maintenance - Building	4223	0.00	866.67	1,905.64	9,533.37	10,400.00	8,494.36	81.67%
Maintenance - Equipment	4225	0.00	1,083.33	6,718.04	11,916.63	13,000.00	6,281.96	48.32%
Maintenance - Grounds	4227	0.00	583.33	4,165.56	6,416.63	7,000.00	2,834.44	40.49%
Postage/Mailings	4233	0.00	433.33	4,770.66	4,766.63	5,200.00	429.34	8.25%
Printing and Forms	4235	0.00	333.33	1,411.83	3,666.63	4,000.00	2,588.17	64.70%
Public Relations	4239	52.54	2,416.67	16,830.00	26,583.37	29,000.00	12,170.00	41.96%
Rent - Equipment	4243	0.00	200.00	1,826.75	2,200.00	2,400.00	573.25	23.88%
Supplies - Office	4253	214.49	916.67	7,656.73	10,083.37	11,000.00	3,343.27	30.39%
Supplies - Other	4257	0.00	104.17	41.95	1,145.87	1,250.00	1,208.05	96.64%
Training and Education	4263	0.00	375.00	2,051.00	4,125.00	4,500.00	2,449.00	54.42%
Travel/Meetings	4265	0.00	166.67	138.17	1,833.37	2,000.00	1,861.83	93.09%
Telephone	4267	11,082.85	5,208.33	46,528.06	57,291.63	62,500.00	15,971.94	25.55%
Utilities (Elec,Gas,Wtr,Sewer)	4271	200.10	291.67	2,283.63	3,208.37	3,500.00	1,216.37	34.75%
Vehicle (Gas and Oil)	4273	239.33	658.33	4,999.38	7,241.63	7,900.00	2,900.62	36.71%
ESDA	4279	0.00	0.00	360.00	2,000.00	2,000.00	1,640.00	82.00%
<b>Total Materials and Supplies</b>		<u>12,500.86</u>	<u>16,847.50</u>	<u>138,903.51</u>	<u>207,322.50</u>	<u>224,170.00</u>	<u>85,266.49</u>	<u>38.04%</u>

**CITY OF DARIEN**  
**Statement of Revenues and Expenditures - Expenditures**  
**General Fund**  
**Administration**  
**From 3/1/2013 Through 3/31/2013**

		Current Period Actual	Current Period Budget	Current Year Actual	YTD Budget	Total Budget	Total Budget Variance	Percent Total Budget Remaining
Contractual								
Audit	4320	0.00	0.00	12,200.00	12,000.00	12,000.00	(200.00)	(1.66)%
Consulting/Professional	4325	7,297.36	7,192.08	67,058.91	79,112.88	86,305.00	19,246.09	22.30%
Conslt/Prof Reimbursable	4328	0.00	0.00	721.95	0.00	0.00	(721.95)	0.00%
Contingency	4330	0.00	833.33	2,696.25	9,166.63	10,000.00	7,303.75	73.03%
Janitorial Service	4345	1,182.00	1,375.00	13,002.00	15,125.00	16,500.00	3,498.00	21.20%
Total Contractual		<u>8,479.36</u>	<u>9,400.41</u>	<u>95,679.11</u>	<u>115,404.51</u>	<u>124,805.00</u>	<u>29,125.89</u>	<u>23.34%</u>
Other Charges								
Transfer to Other Funds	4605	0.00	0.00	2,800,000.00	2,800,000.00	2,800,000.00	0.00	0.00%
Total Other Charges		<u>0.00</u>	<u>0.00</u>	<u>2,800,000.00</u>	<u>2,800,000.00</u>	<u>2,800,000.00</u>	<u>0.00</u>	<u>0.00%</u>
Total Expenditures		<u>69,252.53</u>	<u>75,074.08</u>	<u>3,619,970.72</u>	<u>3,703,580.88</u>	<u>3,778,667.00</u>	<u>158,696.28</u>	<u>4.20%</u>
Total		(69,252.53)	(75,074.08)	(3,619,970.72)	(3,703,580.88)	(3,778,667.00)	(158,696.28)	0.00%

**CITY OF DARIEN**  
**Statement of Revenues and Expenditures - Expenditures**  
**General Fund**  
**City Council**  
**From 3/1/2013 Through 3/31/2013**

		Current Period Actual	Current Period Budget	Current Year Actual	YTD Budget	Total Budget	Total Budget Variance	Percent Total Budget Remaining
Expenditures								
Salaries								
Salaries	4010	3,562.50	3,562.50	39,187.50	39,187.50	42,750.00	3,562.50	8.33%
Total Salaries		3,562.50	3,562.50	39,187.50	39,187.50	42,750.00	3,562.50	8.33%
Benefits								
Social Security	4110	220.88	220.92	2,586.19	2,430.12	2,651.00	64.81	2.44%
Medicare	4111	51.67	51.67	604.98	568.37	620.00	15.02	2.42%
Total Benefits		272.55	272.59	3,191.17	2,998.49	3,271.00	79.83	2.44%
Materials and Supplies								
Boards and Commissions	4205	109.50	208.33	1,335.06	2,291.63	2,500.00	1,164.94	46.59%
Cable Operations	4206	33,335.00	1,875.00	33,335.00	20,625.00	22,500.00	(10,835.00)	(48.15)%
Dues and Subscriptions	4213	0.00	0.00	0.00	100.00	100.00	100.00	100.00%
Liability Insurance	4219	1,688.77	3,494.17	30,959.22	38,435.87	41,930.00	10,970.78	26.16%
Public Relations	4239	0.00	166.67	1,272.70	1,833.37	2,000.00	727.30	36.36%
Supplies - Other	4257	0.00	0.00	45.03	0.00	0.00	(45.03)	0.00%
Travel/Meetings	4265	0.00	0.00	85.00	1,000.00	1,000.00	915.00	91.50%
Total Materials and Supplies		35,133.27	5,744.17	67,032.01	64,285.87	70,030.00	2,997.99	4.28%
Contractual								
Consulting/Professional	4325	1,682.00	1,250.00	3,044.50	13,750.00	15,000.00	11,955.50	79.70%
Trolley Contracts	4366	0.00	0.00	248.84	900.00	900.00	651.16	72.35%
Total Contractual		1,682.00	1,250.00	3,293.34	14,650.00	15,900.00	12,606.66	79.29%
Total Expenditures		40,650.32	10,829.26	112,704.02	121,121.86	131,951.00	19,246.98	14.59%
Total		(40,650.32)	(10,829.26)	(112,704.02)	(121,121.86)	(131,951.00)	(19,246.98)	0.00%

**CITY OF DARIEN**  
**Statement of Revenues and Expenditures - Expenditures**  
**General Fund**  
**Community Development**  
**From 3/1/2013 Through 3/31/2013**

		Current Period Actual	Current Period Budget	Current Year Actual	YTD Budget	Total Budget	Total Budget Variance	Percent Total Budget Remaining
<b>Expenditures</b>								
<b>Salaries</b>								
Salaries	4010	20,187.93	21,370.00	257,113.26	256,440.00	277,807.00	20,693.74	7.44%
Overtime	4030	504.48	41.67	504.48	458.37	500.00	(4.48)	(0.89)%
<b>Total Salaries</b>		<u>20,692.41</u>	<u>21,411.67</u>	<u>257,617.74</u>	<u>256,898.37</u>	<u>278,307.00</u>	<u>20,689.26</u>	<u>7.43%</u>
<b>Benefits</b>								
Social Security	4110	1,204.72	1,186.00	13,991.70	14,232.00	15,416.00	1,424.30	9.23%
Medicare	4111	289.06	312.00	3,615.25	3,744.00	4,057.00	441.75	10.88%
I.M.R.F.	4115	2,551.75	2,947.33	32,394.52	32,420.63	35,368.00	2,973.48	8.40%
Medical/Life Insurance	4120	3,200.54	3,210.17	35,052.66	35,311.87	38,522.00	3,469.34	9.00%
Supplemental Pensions	4135	276.90	300.00	3,322.80	3,300.00	3,600.00	277.20	7.70%
<b>Total Benefits</b>		<u>7,522.97</u>	<u>7,955.50</u>	<u>88,376.93</u>	<u>89,008.50</u>	<u>96,963.00</u>	<u>8,586.07</u>	<u>8.86%</u>
<b>Materials and Supplies</b>								
Boards and Commissions	4205	400.00	200.00	1,379.00	2,200.00	2,400.00	1,021.00	42.54%
Dues and Subscriptions	4213	0.00	62.50	453.00	687.50	750.00	297.00	39.60%
Liability Insurance	4219	1,352.50	3,461.67	32,642.50	38,078.37	41,540.00	8,897.50	21.41%
Maintenance - Vehicles	4229	0.00	100.00	428.80	1,100.00	1,200.00	771.20	64.26%
Printing and Forms	4235	0.00	219.92	985.00	2,419.12	2,639.00	1,654.00	62.67%
Supplies - Office	4253	114.15	37.50	114.15	412.50	450.00	335.85	74.63%
Training and Education	4263	0.00	41.67	0.00	458.37	500.00	500.00	100.00%
Travel/Meetings	4265	0.00	116.67	120.00	1,283.37	1,400.00	1,280.00	91.42%
Vehicle (Gas and Oil)	4273	119.81	166.25	1,174.94	1,828.75	1,995.00	820.06	41.10%
<b>Total Materials and Supplies</b>		<u>1,986.46</u>	<u>4,406.18</u>	<u>37,297.39</u>	<u>48,467.98</u>	<u>52,874.00</u>	<u>15,576.61</u>	<u>29.46%</u>
<b>Contractual</b>								
Consulting/Professional	4325	2,940.20	2,455.58	39,958.70	27,011.38	29,467.00	(10,491.70)	(35.60)%
Const/Prof Reimbursable	4328	4,252.27	4,528.92	42,846.52	49,818.12	54,347.00	11,500.48	21.16%
<b>Total Contractual</b>		<u>7,192.47</u>	<u>6,984.50</u>	<u>82,805.22</u>	<u>76,829.50</u>	<u>83,814.00</u>	<u>1,008.78</u>	<u>1.20%</u>
<b>Total Expenditures</b>		<u>37,394.31</u>	<u>40,757.85</u>	<u>466,097.28</u>	<u>471,204.35</u>	<u>511,958.00</u>	<u>45,860.72</u>	<u>8.96%</u>
<b>Total</b>		<u>(37,394.31)</u>	<u>(40,757.85)</u>	<u>(466,097.28)</u>	<u>(471,204.35)</u>	<u>(511,958.00)</u>	<u>(45,860.72)</u>	<u>0.00%</u>

**CITY OF DARIEN**  
**Statement of Revenues and Expenditures - Expenditures**  
**General Fund**  
**Public Works, Streets**  
**From 3/1/2013 Through 3/31/2013**

		Current Period Actual	Current Period Budget	Current Year Actual	YTD Budget	Total Budget	Total Budget Variance	Percent Total Budget Remaining
<b>Expenditures</b>								
<b>Salaries</b>								
Salaries	4010	30,659.09	38,386.00	440,055.10	460,632.00	499,022.00	58,966.90	11.81%
Overtime	4030	8,129.63	6,666.67	38,594.91	73,333.37	80,000.00	41,405.09	51.75%
<b>Total Salaries</b>		<b>38,788.72</b>	<b>45,052.67</b>	<b>478,650.01</b>	<b>533,965.37</b>	<b>579,022.00</b>	<b>100,371.99</b>	<b>17.33%</b>
<b>Benefits</b>								
Social Security	4110	3,822.14	4,400.00	45,308.51	52,800.00	57,204.00	11,895.49	20.79%
Medicare	4111	893.91	1,029.00	10,598.54	12,349.00	13,378.00	2,779.46	20.77%
I.M.R.F.	4115	8,780.27	8,481.00	96,197.06	101,771.00	110,251.00	14,053.94	12.74%
Medical/Life Insurance	4120	10,969.41	13,039.08	109,694.09	143,429.88	156,469.00	46,774.91	29.89%
Supplemental Pensions	4135	92.30	200.00	2,076.75	2,200.00	2,400.00	323.25	13.46%
<b>Total Benefits</b>		<b>24,558.03</b>	<b>27,149.08</b>	<b>263,874.95</b>	<b>312,549.88</b>	<b>339,702.00</b>	<b>75,827.05</b>	<b>22.32%</b>
<b>Materials and Supplies</b>								
Liability Insurance	4219	945.88	4,761.83	51,677.81	52,380.13	57,142.00	5,464.19	9.56%
Maintenance - Building	4223	6,004.17	6,748.83	38,777.58	74,237.13	80,986.00	42,208.42	52.11%
Maintenance - Equipment	4225	1,238.23	1,754.17	16,299.04	19,295.87	21,050.00	4,750.96	22.56%
Maintenance - Vehicles	4229	2,251.30	2,541.67	26,460.94	27,958.37	30,500.00	4,039.06	13.24%
Postage/Mailings	4233	0.00	83.33	1,260.00	916.63	1,000.00	(260.00)	(26.00)%
Rent - Equipment	4243	0.00	1,912.50	5,586.25	21,037.50	22,950.00	17,363.75	75.65%
Supplies - Office	4253	38.28	131.25	4,393.14	1,443.75	1,575.00	(2,818.14)	(178.92)%
Supplies - Other	4257	166.17	3,341.66	19,785.45	36,708.26	40,050.00	20,264.55	50.59%
Small Tools & Equipment	4259	196.68	320.83	3,596.52	3,529.13	3,850.00	253.48	6.58%
Training and Education	4263	0.00	472.92	1,109.00	5,202.12	5,675.00	4,566.00	80.45%
Uniforms	4269	1,172.29	536.67	4,035.11	5,903.37	6,440.00	2,404.89	37.34%
Utilities (Elec,Gas,Wtr,Sewer)	4271	709.48	304.17	2,373.73	3,345.87	3,650.00	1,276.27	34.96%
Vehicle (Gas and Oil)	4273	9,704.13	8,079.17	55,565.84	88,870.87	96,950.00	41,384.16	42.68%
<b>Total Materials and Supplies</b>		<b>22,426.61</b>	<b>30,989.00</b>	<b>230,920.41</b>	<b>340,829.00</b>	<b>371,818.00</b>	<b>140,897.59</b>	<b>37.89%</b>
<b>Contractual</b>								
Consulting/Professional	4325	7,162.68	4,133.33	43,510.97	45,466.63	49,600.00	6,089.03	12.27%
Forestry	4350	0.00	3,080.00	20,560.36	33,880.00	36,960.00	16,399.64	44.37%
Street Light Oper & Maint.	4359	12,021.03	7,850.00	77,210.90	86,350.00	94,200.00	16,989.10	18.03%
Mosquito Abatement	4365	0.00	0.00	40,887.00	40,887.00	40,887.00	0.00	0.00%



**CITY OF DARIEN**  
**Statement of Revenues and Expenditures - Expenditures**  
**General Fund**  
**Public Works, Streets**  
**From 3/1/2013 Through 3/31/2013**

		Current Period Actual	Current Period Budget	Current Year Actual	YTD Budget	Total Budget	Total Budget Variance	Percent Total Budget Remaining
Street Sweeping	4373	0.00	0.00	23,863.15	33,435.00	33,435.00	9,571.85	28.62%
Drainage Projects	4374	0.00	0.00	22,050.69	34,500.00	34,500.00	12,449.31	36.08%
Tree Trim/Removal	4375	0.00	0.00	64,966.50	127,702.00	127,702.00	62,735.50	49.12%
Total Contractual		19,183.71	15,063.33	293,049.57	402,220.63	417,284.00	124,234.43	29.77%
Capital Outlay								
Rear Yard Drain Proj-Reimb	4378	0.00	0.00	511.00	0.00	0.00	(511.00)	0.00%
Residential Concrete Program	4381	0.00	0.00	60,483.10	0.00	0.00	(60,483.10)	0.00%
Equipment	4815	0.00	0.00	79,903.00	152,000.00	152,000.00	72,097.00	47.43%
Total Capital Outlay		0.00	0.00	140,897.10	152,000.00	152,000.00	11,102.90	7.30%
Total Expenditures		104,957.07	118,254.08	1,407,392.04	1,741,564.88	1,859,826.00	452,433.96	24.33%
Total		(104,957.07)	(118,254.08)	(1,407,392.04)	(1,741,564.88)	(1,859,826.00)	(452,433.96)	0.00%

**CITY OF DARIEN**  
**Statement of Revenues and Expenditures - Expenditures**  
**General Fund**  
**Police Department**  
**From 3/1/2013 Through 3/31/2013**

		Current Period Actual	Current Period Budget	Current Year Actual	YTD Budget	Total Budget	Total Budget Variance	Percent Total Budget Remaining
<b>Expenditures</b>								
<b>Salaries</b>								
Salaries	4010	29,886.76	32,615.00	382,678.43	391,381.00	423,999.00	41,320.57	9.74%
Salaries - Officers	4020	275,635.75	259,623.00	2,993,644.68	3,115,475.00	3,375,097.00	381,452.32	11.30%
Overtime	4030	22,161.86	39,154.00	378,544.94	469,848.00	509,000.00	130,455.06	25.62%
Federal Unemployment	4040	(515.38)	0.00	0.00	0.00	0.00	0.00	0.00%
<b>Total Salaries</b>		<u>327,168.99</u>	<u>331,392.00</u>	<u>3,754,868.05</u>	<u>3,976,704.00</u>	<u>4,308,096.00</u>	<u>553,227.95</u>	<u>12.84%</u>
<b>Benefits</b>								
Social Security	4110	1,903.00	2,353.50	24,451.51	25,888.50	28,242.00	3,790.49	13.42%
Medicare	4111	3,719.95	4,583.33	46,226.42	50,416.63	55,000.00	8,773.58	15.95%
I.M.R.F.	4115	5,794.18	4,455.67	61,981.13	49,012.37	53,468.00	(8,513.13)	(15.92)%
Medical/Life Insurance	4120	37,065.85	42,134.50	406,391.85	463,479.50	505,614.00	99,222.15	19.62%
Police Pension	4130	0.00	241,294.00	1,092,729.27	782,589.00	1,082,589.00	(10,140.27)	(0.93)%
Supplemental Pensions	4135	3,485.10	4,400.00	41,821.20	48,400.00	52,800.00	10,978.80	20.79%
<b>Total Benefits</b>		<u>51,968.08</u>	<u>299,221.00</u>	<u>1,673,601.38</u>	<u>1,419,786.00</u>	<u>1,777,713.00</u>	<u>104,111.62</u>	<u>5.86%</u>
<b>Materials and Supplies</b>								
Animal Control	4201	0.00	125.00	190.00	1,375.00	1,500.00	1,310.00	87.33%
Auxiliary Police	4203	0.00	700.00	3,027.93	7,700.00	8,400.00	5,372.07	63.95%
Boards and Commissions	4205	0.00	3,416.67	15,903.91	37,583.37	41,000.00	25,096.09	61.20%
Dues and Subscriptions	4213	0.00	308.33	1,719.00	3,391.63	3,700.00	1,981.00	53.54%
Investigation and Equipment	4217	1,034.34	4,136.58	8,295.52	45,502.38	49,639.00	41,343.48	83.28%
Liability Insurance	4219	4,001.75	16,899.17	194,349.42	185,890.87	202,790.00	8,440.58	4.16%
Maintenance - Building	4223	0.00	0.00	100.00	0.00	0.00	(100.00)	0.00%
Maintenance - Equipment	4225	40.00	2,681.92	18,671.93	29,501.12	32,183.00	13,511.07	41.98%
Maintenance - Vehicles	4229	3,171.34	2,166.67	31,798.09	23,833.37	26,000.00	(5,798.09)	(22.30)%
Postage/Mailings	4233	59.41	341.67	3,175.56	3,758.37	4,100.00	924.44	22.54%
Printing and Forms	4235	0.00	375.00	1,122.87	4,125.00	4,500.00	3,377.13	75.04%
Public Relations	4239	0.00	1,229.17	4,006.94	13,520.87	14,750.00	10,743.06	72.83%
Rent - Equipment	4243	8.52	14,252.75	165,091.55	156,780.25	171,033.00	5,941.45	3.47%
Supplies - Office	4253	44.11	583.33	4,971.51	6,416.63	7,000.00	2,028.49	28.97%
Training and Education	4263	1,397.50	1,666.67	12,997.50	18,333.37	20,000.00	7,002.50	35.01%
Travel/Meetings	4265	213.76	733.33	3,391.78	8,066.63	8,800.00	5,408.22	61.45%
Telephone	4267	3,192.84	1,075.00	8,939.30	11,825.00	12,900.00	3,960.70	30.70%

**CITY OF DARIEN**  
**Statement of Revenues and Expenditures - Expenditures**  
**General Fund**  
**Police Department**  
**From 3/1/2013 Through 3/31/2013**

		Current Period Actual	Current Period Budget	Current Year Actual	YTD Budget	Total Budget	Total Budget Variance	Percent Total Budget Remaining
Uniforms	4269	2,924.13	3,412.50	20,462.05	37,537.50	40,950.00	20,487.95	50.03%
Utilities (Elec,Gas,Wtr,Sewer)	4271	0.00	833.33	3,683.27	9,166.63	10,000.00	6,316.73	63.16%
Vehicle (Gas and Oil)	4273	9,667.01	11,386.42	103,889.83	125,250.62	136,637.00	32,747.17	23.96%
Total Materials and Supplies		25,754.71	66,323.51	605,787.96	729,558.61	795,882.00	190,094.04	23.88%
Contractual								
Consulting/Professional	4325	0.00	29,745.00	343,208.85	327,195.00	356,940.00	13,731.15	3.84%
Dumeg/Fiat/Child Center	4337	0.00	2,186.67	26,240.00	24,053.37	26,240.00	0.00	0.00%
Total Contractual		0.00	31,931.67	369,448.85	351,248.37	383,180.00	13,731.15	3.58%
Capital Outlay								
Equipment	4815	148.29	2,650.00	76,397.65	29,150.00	31,800.00	(44,597.65)	(140.24)%
Total Capital Outlay		148.29	2,650.00	76,397.65	29,150.00	31,800.00	(44,597.65)	(140.24)%
Total Expenditures		405,040.07	731,518.18	6,480,103.89	6,506,446.98	7,296,671.00	816,567.11	11.19%
Total		(405,040.07)	(731,518.18)	(6,480,103.89)	(6,506,446.98)	(7,296,671.00)	(816,567.11)	0.00%

**CITY OF DARIEN**  
**Statement of Revenues and Expenditures - Expenditures**  
**General Fund**  
**Business District**  
**From 3/1/2013 Through 3/31/2013**

		Current Period Actual	Current Period Budget	Current Year Actual	YTD Budget	Total Budget	Total Budget Variance	Percent Total Budget Remaining
Expenditures								
Materials and Supplies								
Liability Insurance	4219	0.00	275.00	3,500.00	3,025.00	3,300.00	(200.00)	(6.06)%
Maintenance - Equipment	4225	0.00	1,458.33	468.53	16,041.63	17,500.00	17,031.47	97.32%
Maintenance - Grounds	4227	(142.54)	2,666.67	15,627.98	29,333.37	32,000.00	16,372.02	51.16%
Utilities (Elec, Gas, Wtr, Sewer)	4271	391.84	208.33	8,490.56	2,291.63	2,500.00	(5,990.56)	(239.62)%
Total Materials and Supplies		<u>249.30</u>	<u>4,608.33</u>	<u>28,087.07</u>	<u>50,691.63</u>	<u>55,300.00</u>	<u>27,212.93</u>	<u>49.21%</u>
Total Expenditures		<u>249.30</u>	<u>4,608.33</u>	<u>28,087.07</u>	<u>50,691.63</u>	<u>55,300.00</u>	<u>27,212.93</u>	<u>49.21%</u>
Total		(249.30)	(4,608.33)	(28,087.07)	(50,691.63)	(55,300.00)	(27,212.93)	0.00%

**CITY OF DARIEN**  
**Statement of Revenues and Expenditures - Expenditures**  
**Water Fund**  
**Public Works, Water**  
**From 3/1/2013 Through 3/31/2013**

		Current Period Actual	Current Period Budget	Current Year Actual	YTD Budget	Total Budget	Total Budget Variance	Percent Total Budget Remaining
<b>Expenditures</b>								
<b>Salaries</b>								
Salaries	4010	37,340.05	35,042.00	461,079.65	420,504.00	455,542.00	(5,537.65)	(1.21)%
Overtime	4030	3,682.77	3,846.00	26,966.78	46,152.00	50,000.00	23,033.22	46.06%
<b>Total Salaries</b>		<u>41,022.82</u>	<u>38,888.00</u>	<u>488,046.43</u>	<u>466,656.00</u>	<u>505,542.00</u>	<u>17,495.57</u>	<u>3.46%</u>
<b>Benefits</b>								
Social Security	4110	2,398.71	2,650.00	28,845.08	31,798.00	34,444.00	5,598.92	16.25%
Medicare	4111	560.98	620.00	6,745.91	7,438.00	8,055.00	1,309.09	16.25%
I.M.R.F.	4115	4,203.98	5,206.00	44,162.47	62,470.00	67,672.00	23,509.53	34.74%
Medical/Life Insurance	4120	5,936.11	9,163.42	65,455.62	100,797.62	109,961.00	44,505.38	40.47%
Supplemental Pensions	4135	276.90	210.00	3,322.80	2,310.00	2,520.00	(802.80)	(31.85)%
<b>Total Benefits</b>		<u>13,376.68</u>	<u>17,849.42</u>	<u>148,531.88</u>	<u>204,813.62</u>	<u>222,652.00</u>	<u>74,120.12</u>	<u>33.29%</u>
<b>Materials and Supplies</b>								
Liability Insurance	4219	533.40	11,063.42	119,150.85	121,697.62	132,761.00	13,610.15	10.25%
Maintenance - Building	4223	968.80	2,914.83	19,864.80	32,063.13	34,978.00	15,113.20	43.20%
Maintenance - Equipment	4225	3,914.48	1,283.33	20,920.98	14,116.63	15,400.00	(5,520.98)	(35.85)%
Maintenance - Water System	4231	6,172.64	10,808.33	115,416.66	118,891.63	129,700.00	14,283.34	11.01%
Postage/Mailings	4233	0.00	83.33	200.94	916.63	1,000.00	799.06	79.90%
Quality Control	4241	247.50	1,441.67	5,106.52	15,858.37	17,300.00	12,193.48	70.48%
Service Charge	4251	20,833.34	20,833.33	229,166.74	229,166.63	250,000.00	20,833.26	8.33%
Supplies - Operation	4255	0.00	530.00	256.05	5,830.00	6,360.00	6,103.95	95.97%
Training and Education	4263	0.00	295.33	1,315.00	3,248.63	3,544.00	2,229.00	62.89%
Telephone	4267	1,927.27	895.75	8,248.29	9,853.25	10,749.00	2,500.71	23.26%
Uniforms	4269	231.89	258.33	2,059.61	2,841.63	3,100.00	1,040.39	33.56%
Utilities (Elec,Gas,Wtr,Sewer)	4271	4,233.40	4,068.75	36,325.79	44,756.25	48,825.00	12,499.21	25.60%
Vehicle (Gas and Oil)	4273	1,293.80	1,645.83	19,584.53	18,104.13	19,750.00	165.47	0.83%
<b>Total Materials and Supplies</b>		<u>40,356.52</u>	<u>56,122.23</u>	<u>577,616.76</u>	<u>617,344.53</u>	<u>673,467.00</u>	<u>95,850.24</u>	<u>14.23%</u>
<b>Contractual</b>								
Audit	4320	0.00	0.00	10,000.00	10,000.00	10,000.00	0.00	0.00%
Consulting/Professional	4325	0.00	1,083.33	6,648.92	11,916.63	13,000.00	6,351.08	48.85%
Leak Detection	4326	0.00	1,583.33	5,071.00	17,416.63	19,000.00	13,929.00	73.31%

**CITY OF DARIEN**  
**Statement of Revenues and Expenditures - Expenditures**  
**Water Fund**  
**Public Works, Water**  
**From 3/1/2013 Through 3/31/2013**

		Current Period Actual	Current Period Budget	Current Year Actual	YTD Budget	Total Budget	Total Budget Variance	Percent Total Budget Remaining
Data Processing	4336	25,709.75	12,500.00	127,638.50	137,500.00	150,000.00	22,361.50	14.90%
DuPage Water Commission	4340	266,109.37	272,225.67	2,955,317.81	2,994,482.37	3,266,708.00	311,390.19	9.53%
Total Contractual		291,819.12	287,392.33	3,104,676.23	3,171,315.63	3,458,708.00	354,031.77	10.24%
Other Charges								
Transfer to Other Funds	4605	0.00	0.00	500,000.00	500,000.00	500,000.00	0.00	0.00%
Total Other Charges		0.00	0.00	500,000.00	500,000.00	500,000.00	0.00	0.00%
Capital Outlay								
Equipment	4815	0.00	3,280.42	26,007.34	36,084.62	39,365.00	13,357.66	33.93%
Water Meter Purchases	4880	0.00	2,083.33	10,766.95	22,916.63	25,000.00	14,233.05	56.93%
Total Capital Outlay		0.00	5,363.75	36,774.29	59,001.25	64,365.00	27,590.71	42.87%
Debt Service								
Debt Retire	4905	0.00	0.00	305,081.90	305,908.00	305,908.00	826.10	0.27%
Debt Retire-Water Refunding	4950	0.00	0.00	26,030.58	0.00	0.00	(26,030.58)	0.00%
Total Debt Service		0.00	0.00	331,112.48	305,908.00	305,908.00	(25,204.48)	(8.24)%
Total Expenditures		386,575.14	405,615.73	5,186,758.07	5,325,039.03	5,730,642.00	543,883.93	9.49%
Total		(386,575.14)	(405,615.73)	(5,186,758.07)	(5,325,039.03)	(5,730,642.00)	(543,883.93)	0.00%

**CITY OF DARIEN**  
**Statement of Revenues and Expenditures - Expenditures**  
**Motor Fuel Tax**  
**MFT Expenses**  
**From 3/1/2013 Through 3/31/2013**

		Current Period Actual	Current Period Budget	Current Year Actual	YTD Budget	Total Budget	Total Budget Variance	Percent Total Budget Remaining
Expenditures								
Salaries								
Salaries	4010	25,000.00	25,000.00	275,000.00	275,000.00	300,000.00	25,000.00	8.33%
Total Salaries		25,000.00	25,000.00	275,000.00	275,000.00	300,000.00	25,000.00	8.33%
Materials and Supplies								
Road Material	4245	702.00	2,780.00	28,321.92	30,580.00	33,360.00	5,038.08	15.10%
Salt	4249	113,162.59	15,000.00	175,428.75	165,000.00	180,000.00	4,571.25	2.53%
Supplies - Other	4257	0.00	1,250.00	8,114.76	13,750.00	15,000.00	6,885.24	45.90%
Pavement Striping	4261	0.00	0.00	8,168.12	8,500.00	8,500.00	331.88	3.90%
Total Materials and Supplies		113,864.59	19,030.00	220,033.55	217,830.00	236,860.00	16,826.45	7.10%
Total Expenditures		138,864.59	44,030.00	495,033.55	492,830.00	536,860.00	41,826.45	7.79%
Total		(138,864.59)	(44,030.00)	(495,033.55)	(492,830.00)	(536,860.00)	(41,826.45)	0.00%

**CITY OF DARIEN**  
**Statement of Revenues and Expenditures - Expenditures**  
**Special Service Area Tax Fund**  
**SSA Expenditures**  
**From 3/1/2013 Through 3/31/2013**

		Current Period Actual	Current Period Budget	Current Year Actual	YTD Budget	Total Budget	Total Budget Variance	Percent Total Budget Remaining
Expenditures								
Contractual								
Consulting/Professional	4325	0.00	208.33	4,981.50	2,291.63	2,500.00	(2,481.50)	(99.26)%
Maintenance Contracts	4362	0.00	116.67	0.00	1,283.37	1,400.00	1,400.00	100.00%
Contractual Services	4370	0.00	250.00	0.00	2,750.00	3,000.00	3,000.00	100.00%
Total Contractual		<u>0.00</u>	<u>575.00</u>	<u>4,981.50</u>	<u>6,325.00</u>	<u>6,900.00</u>	<u>1,918.50</u>	<u>27.80%</u>
Total Expenditures		<u>0.00</u>	<u>575.00</u>	<u>4,981.50</u>	<u>6,325.00</u>	<u>6,900.00</u>	<u>1,918.50</u>	<u>27.80%</u>
Total		0.00	(575.00)	(4,981.50)	(6,325.00)	(6,900.00)	(1,918.50)	0.00%



**CITY OF DARIEN**  
**Statement of Revenues and Expenditures - Expenditures**  
**Water Depreciation Fund**  
**Depreciation Expenses**  
**From 3/1/2013 Through 3/31/2013**

		Current Period Actual	Current Period Budget	Current Year Actual	YTD Budget	Total Budget	Total Budget Variance	Percent Total Budget Remaining
Expenditures								
Capital Outlay								
Equipment	4815	0.00	0.00	0.00	53,500.00	53,500.00	53,500.00	100.00%
Scada System	4818	0.00	9,166.67	21,907.17	100,833.37	110,000.00	88,092.83	80.08%
Total Capital Outlay		0.00	9,166.67	21,907.17	154,333.37	163,500.00	141,592.83	86.60%
Total Expenditures		0.00	9,166.67	21,907.17	154,333.37	163,500.00	141,592.83	86.60%
Total		0.00	(9,166.67)	(21,907.17)	(154,333.37)	(163,500.00)	(141,592.83)	0.00%

**CITY OF DARIEN**  
**Statement of Revenues and Expenditures - Expenditures**  
**Darien Area Dispatch Center**  
**Darien Area Dispatch**  
**From 3/1/2013 Through 3/31/2013**

	Current Period Actual	Current Period Budget	Current Year Actual	YTD Budget	Total Budget	Total Budget Variance	Percent Total Budget Remaining	
Expenditures								
Other Charges								
Transfer to Other Funds	4605	0.00	0.00	92,860.00	0.00	0.00	(92,860.00)	0.00%
Total Other Charges		0.00	0.00	92,860.00	0.00	0.00	(92,860.00)	0.00%
Debt Service								
Principal	5000	0.00	0.00	107,140.00	0.00	0.00	(107,140.00)	0.00%
Total Debt Service		0.00	0.00	107,140.00	0.00	0.00	(107,140.00)	0.00%
Total Expenditures		0.00	0.00	200,000.00	0.00	0.00	(200,000.00)	0.00%
Total		0.00	0.00	(200,000.00)	0.00	0.00	200,000.00	0.00%

**CITY OF DARIEN**  
**Statement of Revenues and Expenditures - Expenditures**  
**Capital Improvement Fund**  
**Capital Fund Expenditures**  
**From 3/1/2013 Through 3/31/2013**

		Current Period Actual	Current Period Budget	Current Year Actual	YTD Budget	Total Budget	Total Budget Variance	Percent Total Budget Remaining
Expenditures								
Contractual								
Consulting/Professional	4325	0.00	0.00	52,277.50	0.00	0.00	(52,277.50)	0.00%
Total Contractual		0.00	0.00	52,277.50	0.00	0.00	(52,277.50)	0.00%
Capital Outlay								
Ditch Projects	4376	0.00	0.00	282,859.36	884,543.00	884,543.00	601,683.64	68.02%
Sidewalk Replacement Program	4380	0.00	0.00	67,813.74	67,630.00	67,630.00	(183.74)	(0.27)%
Crack Seal Program	4382	0.00	0.00	91,476.00	92,400.00	92,400.00	924.00	1.00%
Curb & Gutter Replacement Prog	4383	0.00	0.00	285,869.83	319,127.00	319,127.00	33,257.17	10.42%
Economic Incentive	4400	0.00	0.00	272,185.64	0.00	0.00	(272,185.64)	0.00%
Equipment	4815	9,759.81	0.00	92,259.74	135,600.00	135,600.00	43,340.26	31.96%
Street Reconstruction/Rehab	4855	0.00	0.00	1,413,109.60	1,506,250.00	1,506,250.00	93,140.40	6.18%
Street Recon Rehab-Reimb	4856	127.25	0.00	168,620.80	0.00	0.00	(168,620.80)	0.00%
Total Capital Outlay		9,887.06	0.00	2,674,194.71	3,005,550.00	3,005,550.00	331,355.29	11.02%
Debt Service								
Debt Retire	4905	0.00	0.00	202,193.76	202,194.00	202,194.00	0.24	0.00%
Debt Retire - Property	4945	0.00	0.00	428.00	0.00	0.00	(428.00)	0.00%
Total Debt Service		0.00	0.00	202,621.76	202,194.00	202,194.00	(427.76)	(0.21)%
Total Expenditures		9,887.06	0.00	2,929,093.97	3,207,744.00	3,207,744.00	278,650.03	8.69%
Total		(9,887.06)	0.00	(2,929,093.97)	(3,207,744.00)	(3,207,744.00)	(278,650.03)	0.00%

**CITY OF DARIEN**  
**Statement of Revenues and Expenditures - Expenditures**  
**Debt Service Fund**  
**Debt Service Fund Expenditures**  
**From 3/1/2013 Through 3/31/2013**

		Current Period Actual	Current Period Budget	Current Year Actual	YTD Budget	Total Budget	Total Budget Variance	Percent Total Budget Remaining
Expenditures								
Contractual								
Contingency	4330	0.00	0.00	375.00	0.00	0.00	(375.00)	0.00%
Total Contractual		0.00	0.00	375.00	0.00	0.00	(375.00)	0.00%
Debt Service								
Debt Service - Series 2007B	4951	0.00	0.00	494,000.00	496,802.00	496,802.00	2,802.00	0.56%
Total Debt Service		0.00	0.00	494,000.00	496,802.00	496,802.00	2,802.00	0.56%
Total Expenditures		0.00	0.00	494,375.00	496,802.00	496,802.00	2,427.00	0.49%
Total		0.00	0.00	(494,375.00)	(496,802.00)	(496,802.00)	(2,427.00)	0.00%

**CITY OF DARIEN -- CASH RESERVES**  
**March 31, 2013**

<b>FUND</b>	<b>FUND NAME</b>	<b>TOTAL</b>
01	General Fund	\$ 2,653,822.07
02	Water Fund	\$ 572,104.49
03	MFT Fund	\$ 270,041.48
05	Impact Fees Fund	\$ 13,206.99
10	Special Service Area Tax Fund	\$ 8,924.41
11	Drug Forfeiture Fund	\$ 5,250.23
12	Water Depreciation Fund	\$ 762,397.58
15	D.A.D.C. Fund	\$ 312,841.75
16	Escrow Fund	\$ 25.87
18	Drug Seizure Fund	\$ 10,399.16
25	Capital Improvement Fund	\$ 4,022,698.90
35	Debt Service Fund	\$ 7,853.77
	<b>TOTAL</b>	<b>\$ 8,639,566.70</b>

*Prior Month Cash Balance*                      **\$ 8,876,459.02**

<b>Bank Accounts and Interest Rates</b>	<b>Account Balances</b>
Republic Bank Drug Forfeiture Account - 1.51%	\$ 11,930.55
Republic Bank Now Account - 1.51%	\$ 8,335,421.71
Republic Bank Operating Account	\$ 141,274.26
Republic Bank Payroll Account - Zero Balance Acct	\$ (16,303.10)
Illinois Funds Money Market Account - .059%	\$ 115,033.70
IMET Investment Fund - .34%	\$ 52,209.58
	<b><u>\$ 8,639,566.70</u></b>

Wells Fargo Collateral Statement                      **Market Value**  
**\$ 9,258,788**

AGENDA MEMO  
City Council Meeting  
April 15, 2013

**ISSUE STATEMENT**

Consideration of a motion to approve the use of the right half of the following streets for the *Hornet Hustle 2013* which begins at the northwest corner of Darien Community Park and proceed as follows:

5K Run - 71<sup>st</sup> Street to Richmond Avenue; south on Richmond Avenue and following Cherokee Drive to Darien Lane; north on Darien Lane and following Timber Lane to Seminole Drive; north on Seminole Drive to 71<sup>st</sup> Street; west on 71<sup>st</sup> Street to Beechnut Lane to Hinsbrook Avenue; east on Hinsbrook Avenue to Wilmette Avenue; north on Wilmette Avenue to 69<sup>th</sup> Street; east on 69<sup>th</sup> Street to Bentley Avenue; south on Bentley Avenue to 71<sup>st</sup> Street; east on 71<sup>st</sup> Street to northwest corner of Darien Community Park with access for emergency vehicles and local traffic at all times; AND

1 Mile Walk – 71<sup>st</sup> Street to Richmond Avenue; north on Richmond Avenue to Maple Lane; east on Maple Lane to Bentley Avenue; south on Bentley Avenue to 71<sup>st</sup> Street; east on 71<sup>st</sup> Street to northwest corner of Darien Community Park with access for emergency vehicles and local traffic at all times.

**[BACKUP](#)**

**BACKGROUND HISTORY**

The City Council is requested to review a request to approve temporary street closures and police service for the Hinsdale South Athletic Club's *Hornet Hustle*, a 5K Run/1 Mile Walk, on Sunday, May 5<sup>th</sup>, 2013 beginning at 8:20 A.M. This motion also gives authorization to the Chief of Police to finalize details for the *Hornet Hustle* with the Hinsdale South Athletic Club.

This is the 4<sup>th</sup> year the *Hornet Hustle* would be held for the benefit of athletic programs for Hinsdale South. Road closures, the number of participants, and size of the event may require additional signage, barricades and expense to the City; any costs incurred by the City will be reimbursed by the Hinsdale South Athletic Club.

**STAFF/COMMITTEE RECOMMENDATION**

Staff recommends approval of the request from the Hinsdale South Athletic Club through the partial closure of certain streets to facilitate the safety and efficient operation of the *Hornet Hustle*. As part of the approval, the Hinsdale South Athletic Club will be required to cover the costs associated with the event. The Athletic Club will also be required to communicate with affected residents along the route.

**ALTERNATE CONSIDERATION**

Not approve the motion at this time.

**DECISION MODE**

This item will be on the April 15, 2013, City Council Agenda for formal consideration.



HINSDALE SOUTH ATHLETIC CLUB  
4701 Clarendon Hills Rd  
Darien IL 60561

April 8, 2013

To Whom It May Concern:

My name is Virginia Stoltz and I am the President of The Hinsdale South Athletic Club. I believe we worked with you last year to secure the date for our annual 5k race. On May 5, we are holding our fourth annual Hornet Hustle 5k. We are requesting permission to hold the event and for proper street closure. A request has also been issued to the Park District to secure this date.

The Athletic Club is a 501c3 organization benefiting all athletic programs at Hinsdale South High School. Our race starts at 8:20 a.m. We expect to have all events completed by noon.

Please visit our website, [www.hinsdalesouthathleticclub.org](http://www.hinsdalesouthathleticclub.org) (click on the hornet hustle) All information on the race is posted on the website including the race map. I hope you can join us race day!!

Please let me know what paperwork needs to be done and how to proceed.

Thank you,  
Virginia Stoltz  
630-768-3058

# HORNET HUSTLE

## Race Course

START LINE: 71st Street even with the west side of the horseshoe-shaped entrance to the park. (See map inset.)  
 MILE 1: Cherokee Dr. 15 ft. east of the east edge of the driveway of 1010 address.  
 MILE 2: Hinsbrook Ave. 12 ft. east of the east edge of the driveway of 1110 address.  
 MILE 3: 71st Street 17 ft. east of east side of driveway of 530 address.  
 FINISH LINE: 71st Street 65.5 ft. east of east side of the horseshoe, 125.5 ft. east of the start line.

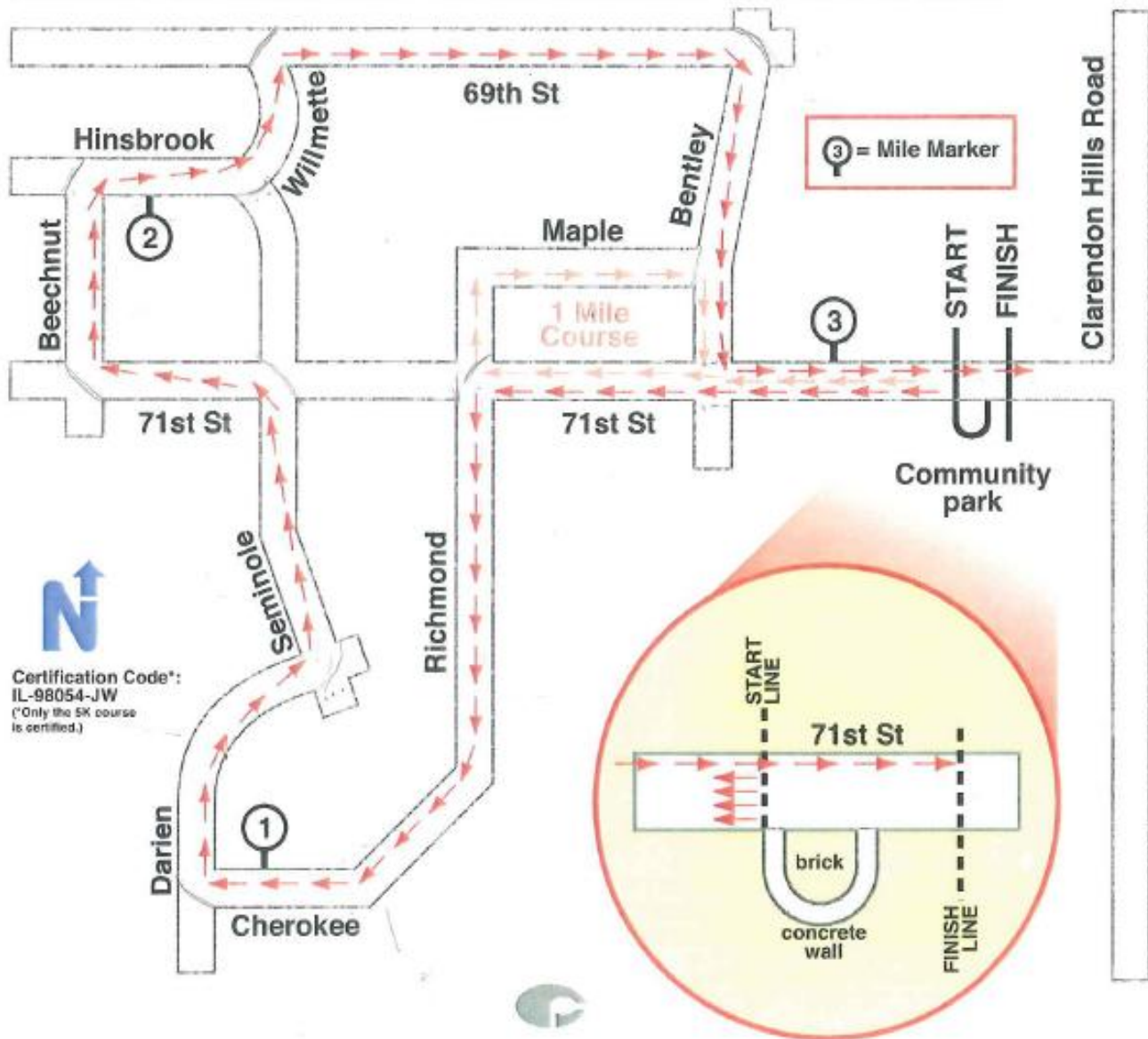



**AGENDA MEMO**  
**City Council**  
**April 15, 2013**

**ISSUE STATEMENT**

A resolution entering into an agreement with Andromeda Technology Solutions to purchase and install a security camera system at 1041 S. Frontage Road.

**RESOLUTION**      **BACKUP**

**BACKGROUND/HISTORY**

At the Municipal Services facility there have been instances of illegal dumping and small thefts of materials over the past few years. Staff budgeted for a security system that would provide surveillance for the area and capture license plates of vehicles entering and leaving the property. Staff made sure to emphasize the system needed to provide a good quality picture, be viewable remotely from computers, have adequate storage for 90 days cover certain areas of the property including material storage areas, the gas pumps, entrances and exits, and a broad area, and be able to expand if desired in the future.

There are many potential solutions for cameras and surveillance, so staff contacted five companies to provide proposals. Three of the companies gave proposals, one company declined due to a large current workload, and one company did not respond.

<b>Company</b>	<b>Price</b>
<a href="#"><u>Andromeda</u></a>	\$16,208.95
<a href="#"><u>First Security Systems</u></a>	\$20,600
<a href="#"><u>Mideo</u></a>	\$30,210 - \$45,671

Staff tested the Andromeda solution, which includes the same software solution used in the police department. It is viewable remotely, and includes 10 total cameras: six on the main municipal services building, three on the salt storage shed building, and one on a pole directed at cars entering and leaving the main entrance to get license plate numbers. The picture quality is sufficient, both during the day and using infrared in the evening. The municipal services department will assist with the installation by providing a lift, as well as providing duct to allow cables for the pole camera at the entrance.

**STAFF/COMMITTEE RECOMMENDATION**

The Administrative/Finance Committee recommends approving the resolution.

**ALTERNATE CONSIDERATION**

Not approving the resolution would be an alternate consideration.

**A RESOLUTION AUTHORIZING THE CITY ADMINISTRATOR TO ENTER INTO AN AGREEMENT WITH ANDROMEDA TECHNOLOGY SOLUTIONS TO PURCHASE AND INSTALL A SECURITY CAMERA SYSTEM AT 1041 S. FRONTAGE ROAD IN AN AMOUNT NOT TO EXCEED \$16,208.95**

**BE IT RESOLVED BY THE CITY COUNCIL OF THE CITY OF DARIEN, DU PAGE COUNTY, ILLINOIS:** A resolution authorizing the City Administrator to enter into an agreement with Andromeda Technology Solutions to purchase and install a security camera system at 1041 S. Frontage Road, a copy of which is attached hereto as "**Exhibit A**".

**PASSED BY THE CITY COUNCIL OF THE CITY OF DARIEN, DUPAGE COUNTY, ILLINOIS,** this 15th day of April, 2013.

AYES: \_\_\_\_\_

\_\_\_\_\_

NAYS: \_\_\_\_\_

\_\_\_\_\_

ABSENT: \_\_\_\_\_

\_\_\_\_\_

**APPROVED BY THE MAYOR OF THE CITY OF DARIEN, DUPAGE COUNTY, ILLINOIS,** this 15th day of April, 2013.

MAYOR

\_\_\_\_\_  
\_\_\_\_\_  
KATHLEEN MOESLE WEAVER,



ATTEST:

---

JOANNE E. RAGONA, CITY CLERK

APPROVED AS TO FORM:

---

CITY ATTORNEY

**Andromeda Technology Solutions**

Phone: (815) 836-0030  
 Fax: (888) 389-9870  
 16624 West 159th Street, Suite 600  
 Lockport, IL 60441

**Quote**

No.: **10526**  
 Date: 04/01/2013

Prepared for:  
 Mr. Scott Coren  
 City of Darien  
 1702 Plainfield Road  
 Darien, IL 60561 U.S.A.

Prepared by: Patrick L. McDonald  
 Account No.: 508  
 Phone: (630) 852-5000  
 Fax: (630) 852-4709

Qty.	Part Number	Description	UOM	Sell	Total
<b>Main Building</b>					
1		8 Channel Pro Series DVR 2TB	EA	\$1,461.45	\$1,461.45
		<i>EasyNet Pro Series</i>			
		<i>• 8-ch (480pps @ CIF)</i>			
		<i>• H.264</i>			
		<i>• Real-time recording per channel</i>			
		<i>• Pentaplex functions</i>			
		<i>• Available in 1TB - 4TB HDD models</i>			
		<i>• Multiple monitor outputs</i>			
		<i>• DVR control methods: Front panel, IR Remote, Mouse, Keyboard (CK-1000)</i>			
		<i>• Built-in DVD burner or USB flashdrive file copy methods</i>			
		<i>• Multi-channel audio support</i>			
		<i>• Watermark</i>			
		<i>• Time synchronization between multiple DVRs</i>			
		<i>• Windows PC &amp; Mac compatible VMS Pro</i>			
		<i>• Free EasyNet Touch mobile app</i>			
		<i>• Free DDNS Service</i>			
6		Camera, Turret, Intensifier, Indoor/Outdoor, 2.8-12mm, 650TVL,12/24V	EA	\$359.36	\$2,156.16
		<i>Specifications</i>			
		<i>• 650 lines of color resolution</i>			
		<i>• Amplify existing light with no distance limitations</i>			
		<i>• No problems caused by objects that reflect or absorb IR light sources</i>			
		<i>• Minimum illumination 0.00002 lux (Intensifier3™ @ 512x)</i>			
		<i>• 12VDC / 24VAC dual voltage operation</i>			
		<i>• Full OSD operation and test monitor output</i>			
		<i>• 3-axis wall or ceiling mount</i>			
		<i>• External controls for zoom &amp; focus</i>			
		<i>• Weather resistant operation</i>			
		<i>• EZ mount system simplifies installation</i>			
		<i>• Relay outputs for motion detection</i>			
		<i>• IP66 compliant</i>			
		<i>• 5 year warranty</i>			
6		Camera, Mount Turret Camera	EA	\$49.65	\$297.90
6.00		Outdoor Camera Mounting Hardware	EA	\$45.00	\$270.00
1		Camera, Power Distribution Box, 8 outputs 24v AC	EA	\$95.52	\$95.52
1		*Switch, 8-Port 10/100/1000	EA	\$140.00	\$140.00
	HP V1410-8G				
2		*Cable, Network Patch 3` White	EA	\$8.00	\$16.00
1		*UPS, 550 APC Back-UPS,ES 550 Green 550VA UPS	EA	\$99.00	\$99.00

**Quote**No.: **10526**

Date: 04/01/2013

Qty.	Part Number	Description	UOM	Sell	Total
<b>Garage Building</b>					
<b>Enclosure for the DVR will be determined during installation. Customer will have to determine what space is available to mount the hardware. We will work with the customer to determine best enclosure to keep hardware protected.</b>					
1		DVR,4 Channel,1TB, EasyNet Compact Series	EA	\$575.89	\$575.89
		<i>Key Features</i>			
		<ul style="list-style-type: none"> <li>• 4-ch</li> <li>• H.264</li> <li>• Real-time recording per channel</li> <li>• Pentaplex functions</li> <li>• Available in 500GB or 1TB HDD models</li> <li>• Multiple monitor outputs</li> <li>• DVR control methods: Front panel, IR Remote, Mouse, Keyboard (CK-1000)</li> <li>• USB flashdrive file copy method</li> <li>• Single channel audio support</li> <li>• Watermark</li> <li>• Time synchronization between multiple DVRs</li> <li>• Windows PC &amp; Mac compatible VMS Pro</li> <li>• Free EasyNet Touch mobile app</li> <li>• Free DDNS Service</li> </ul>			
3		Camera, Turret, Intensifier, Indoor/Outdoor, 2.8-12mm, 650TVL,12/24V	EA	\$359.36	\$1,078.08
		<i>Specifications</i>			
		<ul style="list-style-type: none"> <li>• 650 lines of color resolution</li> <li>• Amplify existing light with no distance limitations</li> <li>• No problems caused by objects that reflect or absorb IR light sources</li> <li>• Minimum illumination 0.00002 lux (Intensifier3™ @ 512x)</li> <li>• 12VDC / 24VAC dual voltage operation</li> <li>• Full OSD operation and test monitor output</li> <li>• 3-axis wall or ceiling mount</li> <li>• External controls for zoom &amp; focus</li> <li>• Weather resistant operation</li> <li>• EZ mount system simplifies installation</li> <li>• Relay outputs for motion detection</li> <li>• IP66 compliant</li> <li>• 5 year warranty</li> </ul>			
3		Camera, Mount Turret Camera	EA	\$49.65	\$148.95
3.00		Outdoor Camera Mounting Hardware	EA	\$45.00	\$135.00
1		Camera Power Distribution Box, 4 outputs 24v AC 4 amps	EA	\$71.03	\$71.03
1		*Switch, 8-Port 10/100/1000	EA	\$140.00	\$140.00
	HP V1410-8G				
2		*Cable, Network Patch 3` White	EA	\$8.00	\$16.00
1		DVR Lockbox with Fan 18x18x5.5	EA	\$131.51	\$131.51
1		*UPS, 550 APC Back-UPS,ES 550 Green 550VA UPS	EA	\$99.00	\$99.00
2,300		Camera Video Cable, RG59, Non-Plenum, Black, Siamese Video with 18g Power Pair	FT	\$0.31	\$713.00
18		BNC Video Connector, BNC RG-59 Crimp Pin and Sleeve	EA	\$1.48	\$26.64

Qty.	Part Number	Description	UOM	Sell	Total
<b>LPR Camera</b>					
<b>Client is providing the pole and the conduit to the camera from the salt shed. Andromeda will give instruction as to where the pole is to be place.</b>					
1		Camera, Bullet, License Plate Recognition	EA	\$961.18	\$961.18
<i>Features</i>					
<i>Summary</i>					
<i>License Plate Recognition Camera</i>					
<ul style="list-style-type: none"> <li>• 1/3" CCD</li> <li>• 620 TV Lines</li> <li>• 6~50mm Varifocal Auto Iris Lens</li> <li>• 13~30ft Capture Range</li> <li>• Plate Recognition Technology Captures License Plates up to 50mph</li> <li>• Reliable Performance under Any Lighting Conditions</li> <li>• Smart DNR (Digital Noise Reduction)</li> <li>• DRC (Dynamic Range Compressor)</li> <li>• Star-Light (Super Low Light Technology)</li> <li>• HME (Highlight Masking Exposure)</li> <li>• Programmable Privacy Zones (8) &amp; Motion Detection</li> <li>• Easy Icon Driven OSD Menu with Built-in Joystick</li> <li>• IP66 Certified (Weatherproof)</li> <li>• No Fog or Condensation under Any Weather Condition</li> <li>• Auto Sensing 12VDC/24VAC with Line Lock</li> <li>• RS-485 Built-in</li> <li>• Secondary Video-BNC Output</li> </ul>					
1		Mount, Junction Back Box, LPR	EA	\$48.51	\$48.51
1		Mount, Pole, LPR, DWD	EA	\$37.81	\$37.81
1.00		Pole mount hardware	EA	\$24.50	\$24.50
2		BNC Video Connector, BNC RG-59 Crimp Pin and Sleeve	EA	\$1.48	\$2.96
300		Camera Video Cable, RG59, Non-Plenum, Black, Siamese Video with 18g Power Pair	FT	\$0.36	\$108.00
5.00		Pull wire to LPR camera. Mount and sight. Sighting of this camera will have to take place at night to get the best imaging.	HR	\$110.00	\$550.00
<b>Wireless Network Bridge used to connect the two buildings. Allow access to garage recorder from City office and main building.</b>					
2		Wireless AP 802.11 a/n High Power Outdoor 5 GHz 300MB	EA	\$147.01	\$294.02
50		Wire, CAT6, Plenum, White	FT	\$1.10	\$55.00
2.00		Wireless AP Mounting Hardware	EA	\$45.00	\$90.00
65.00		Labor for Camera	HR	\$110.00	\$7,150.00

**The above camera system is covered under the 3 year manufactures parts warranty, except where such failure is as a result of Acts of Nature (including fire, flood, earthquake, storm, lightning or other natural disaster), war, invasion, act of foreign enemies, hostilities (whether war is declared or not), civil war, rebellion, revolution, insurrection, military or usurped power or confiscation, terrorist activities, nationalizations, government sanction, blockage, embargo, labor dispute, strike, lockout. Also not covered are failures due to misuse, neglect or abuse.**

**Quote**  
No.: **10526**  
Date: 04/01/2013

---

Item Total:	\$16,993.11
<b>Your Price:</b>	<b>\$16,143.45</b>

Freight:	\$65.50
<b>SubTotal:</b>	<b>\$16,208.95</b>

Existing customer discount.

<b>Total:</b>	<b>\$16,208.95</b>
---------------	--------------------

<b>You saved:</b>	<b>\$849.66</b>
-------------------	-----------------

**For a savings of 5.00%**

Prices are firm until 4/30/2013    Terms: Due on Receipt

---

**Quoted by:** Patrick L. McDonald, PatM@wenetwork.com

**Date:** 4/1/2013

**Accepted by:** \_\_\_\_\_ **Date:** \_\_\_\_\_

**Disclaimer**

PRICES SUBJECT TO CHANGE - PRICES BASED UPON TOTAL PURCHASE - ANY ADDITIONAL DELIVERY, TRAINING OR CONSULTING SERVICES TO BE BILLED AT PUBLISHED RATES FOR EACH ACTIVITY INVOLVED. Andromeda Technology Solutions does not provide a warranty on purchased hardware (parts or entire systems) or software. The original manufacturer's warranty applies to parts or warranty service. Any work done by Andromeda is billable, even if the unit is still covered under the original manufacturer's warranty. This billable work may include, but is not limited to, debugging of hardware or software problems and removing/replacing a piece of hardware supplied by the manufacturer. (The replacement part may be provided free of charge by the manufacturer.) This holds true even if the hardware is covered under an on-site replacement warranty.

For any new devices (telephones, access points, computers etc) that require additional wiring (including network and telephone patch cables, surge protectors, etc), the work will be billed Time & Materials at our standard rates (unless that wiring is specifically covered in a line item above.) For any existing building wiring that is not station-to-station, does not follow standard color coding, or is below needed specifications, any additional work that is incurred will be billed Time & Materials at our standard rates.

Please Sign above and fax back to (888) 389-9870 (or Email to your account manager) to accept this quotation. For new customers, or existing customers with quotations over \$2,000, a 50% payment will be required before any hardware is ordered. The balance will be due 25% upon hardware delivery and the final 25% due upon completion of the job.

Please note, any parking charges incurred during any visits to your facility will be added on to your service invoice. Also, a fuel surcharge fee may be added on a per invoice basis as well.

IMPORTANT: You agree that you have reviewed the terms and conditions of the Services Agreement located at [www.WeNetwork.com/agree.htm](http://www.WeNetwork.com/agree.htm) and that your purchase is subject to these terms and conditions. By signing this quotation you are subject to the terms of the agreement.

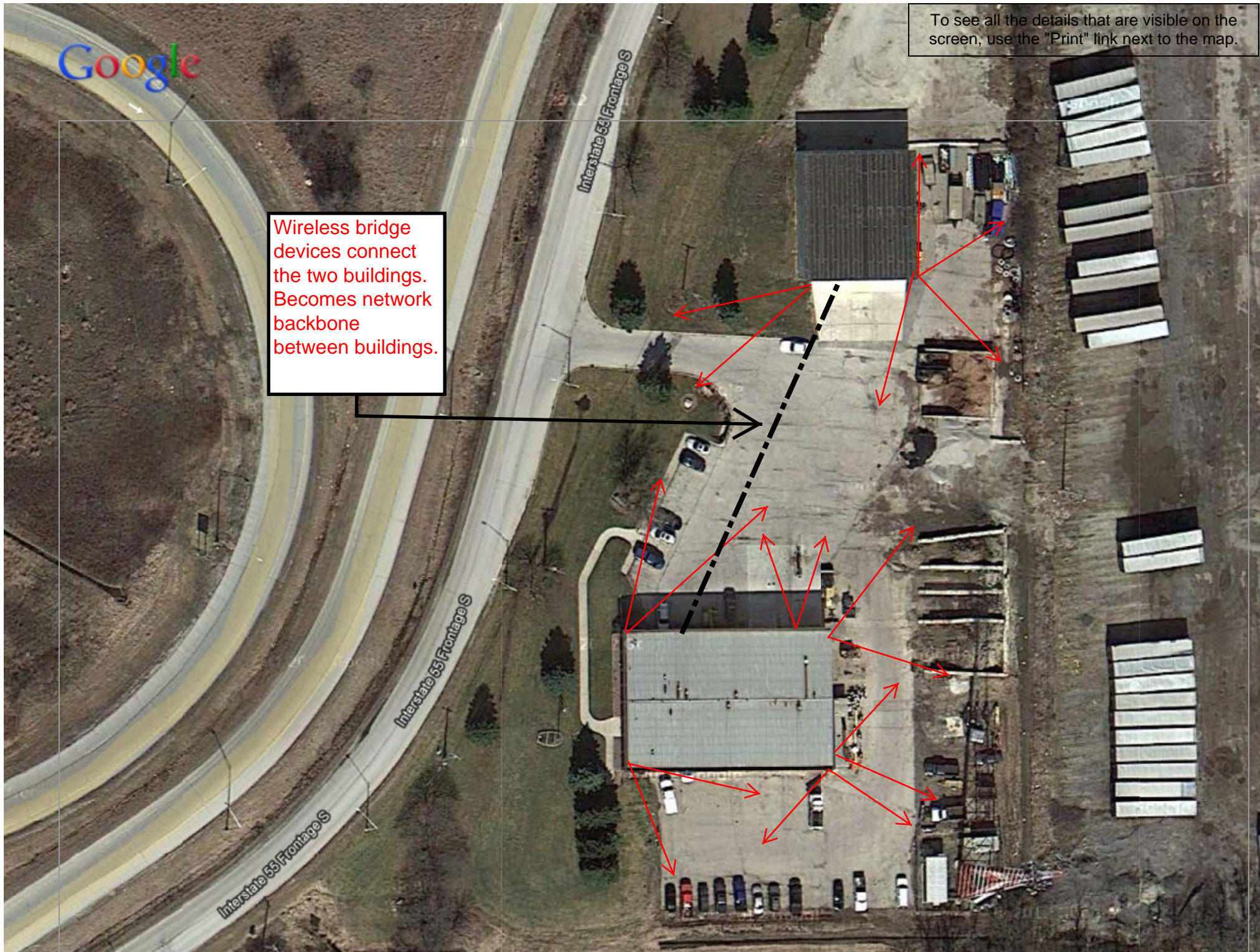

To see all the details that are visible on the screen, use the "Print" link next to the map.

Wireless bridge devices connect the two buildings. Becomes network backbone between buildings.



March 28, 2013



First Security Systems, Inc.  
1811 High Grove Lane  
Suite 191  
Naperville, IL 60540

Mr. Scott Coren  
Assistant City Administrator  
City of Darien  
Darien, IL

tel. 630.961.5900  
fax. 630.961.9540

RE: Darien Public Works CCTV – 1041 Frontage Road

First Security Systems is pleased to provide you this proposal for the above referenced project. This proposal is based on discussions and a walk-through of the facility.

<u>Item</u>	<u>Quantity</u>	<u>Description</u>
1.	1	Interlogix NVR 4-TB
2.	5	Honeywell IP Camera
3.	2	Fluid Mesh Radio (field) (FM1100M-HW, FM1100M-05)
4.	1	Fluid Mesh Receiver (at main building) (FM3100M-HW)
5.	1	POE Switch
6.	LOT	Installation Materials, plenum rated cable
7.	LOT	Labor to Program, Test, Train

**Notes/Scope of Work**

- Power to be provided at all remote locations
- Lift to access high areas to mount cameras to be provided
- All work to be completed during normal business hours
- Alternate #2 does not affect price.
- Any poles required (alternate #2) to be provided and installed by others

**Total Project Cost \$20,600.00**

*This Proposal is based on the First Security Systems, Inc. Standard Terms and Conditions and the "Scope of Work" and are to be considered part of this proposal. (Available upon Request) Proposal is valid for thirty (30) days from below date.*

Proposal Accepted:  
First Security Systems, Inc. is authorized to

Proposal Submitted:  
First Security Systems, Inc.

Proceed with the work proposed.

Purchaser \_\_\_\_\_

By: Kurt Lindquist

Signature \_\_\_\_\_

Signature

Title \_\_\_\_\_

Title Service Sales Fire/Security

Date \_\_\_\_\_

Date February 1, 2011

# The Fluidmesh Mito Series

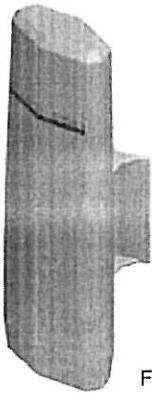

FM1100M-HW

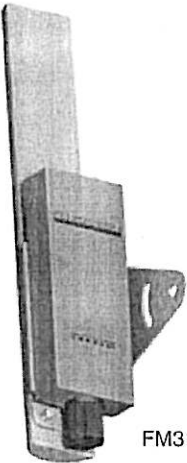

FM3100M-HW

## MITO Point-to-Point Usable Throughput

Throughput (Mbps)	Max Range (miles)	Max Range (Km)
100	5	8
50	10	16
30	15	24
20	18	28
15	20	30

\*performances are based on the SNR of the link.

## Supported Architectures



Point-to-Point



Point-to-Multipoint



Mesh



Mixed

## SOLUTIONS

- Cellular and Wi-Max Backhauling
- Enterprise Backhauling
- Rural and Municipal Broadband
- Industrial and SCADA
- Smartgrids
- Video Surveillance
- Transportation and Railways
- Military and Government

**FLUIDMESH**  
NETWORKS   
A Corlick Seed Company

The Fluidmesh® MITO Series is a MIMO-based tri-band wireless Ethernet product line designed and manufactured specifically for multi-service backhaul applications.

### MITO – The Revolution in Wireless Backhauling

With the MITO product line, Fluidmesh has developed a revolutionary wireless backhaul solution that is capable of offering extreme performances with a small form factor. MITO is a unique 2x2 MIMO solution with integrated directional antennas which has allowed Fluidmesh to break the mould and create a product line that is a game changer in the wireless backhauling arena. You won't need to install external antennas. You won't need to deal with coaxial cables, lightning suppressors, and grounding. The Fluidmesh 1100 MITO and the Fluidmesh 3100 MITO have an integrated radio-antenna solution with an outdoor rated enclosure that is slightly bigger than two decks of cards. The Fluidmesh 1100 MITO mounts a 2x2 MIMO patch antenna and can be used to create point to point, point to multipoint, and mesh networks providing unparalleled performances and a compact form factor. The Fluidmesh 3100 MITO mounts a 2x2 MIMO sector antenna and is designed for medium and large point to multipoint deployments with up to 150 clients.

### Tri-band Radio operating at 4.9 GHz, and 5.1-5.8 GHz

The Fluidmesh MITO Series features one tri-band radio and can operate at 4.9 GHz, and 5.1-5.8 GHz and modulate up to 300 Mbps. The preferred frequency can be easily selected through a web based interface.

### Optimized Prodigy Transmission Protocol for maximum Reliability

The Fluidmesh MITO Series employs Prodigy, Fluidmesh's proprietary high performance 'intelligent' transmission protocol, built to overcome the limits of standard license-free protocols and to deliver a wireless infrastructure with a higher level of reliability. Prodigy was developed to transmit any IP-compatible traffic including data, video, and voice. At the base of our innovative transmission protocol, there is a traffic optimization algorithm that allows every Fluidmesh device to assign a specific level of priority and reliability to every packet transmitted. This process allows the wireless network to automatically adjust its transmission parameters based on the type of traffic transmitted. The overall result is a better, more reliable, multi-service wireless infrastructure.

### Compact Design for Easy Installation

The Fluidmesh MITO Series has a compact form factor designed for low visual impact deployments. The integrated panel antenna makes for easy installation and supports a range of up to 30 miles in line of sight. The provided low-power POE injector guarantees a straight-forward set-up.

### FluidThrottle™

The Fluidmesh MITO Series is based on the innovative FluidThrottle™ technology which allows the user to limit the total cost of ownership of the wireless network by paying only for the amount of bandwidth required. Additional throughput can be easily achieved by upgrading the system with software plug-ins in case the bandwidth requirements increase over time. This solution makes Fluidmesh the most cost-effective and flexible wireless solution provider in the market.

### FluidMAX™

The Fluidmesh MITO Series supports the patent-pending FluidMAX™ technology and can be used to create Point-to-Point, Point-to-Multipoint, and Mesh architectures. Thanks to FluidMAX™, the Fluidmesh MITO Series can operate with a centralized medium access control protocol, or with a distributed medium access control protocol, depending on the network layout. That means that our units can operate in either CSMA or TDMA. The decision is made automatically by the network based on its layout and requires no user intervention.

### EasyMesh™ Platform and FMQuadro Interface

The Fluidmesh MITO Series includes EasyMesh™. The EasyMesh technology allows the user to set the same range of private IP addresses across the entire network. The Fluidmesh MITO Series also includes the FMQuadro™ web interface which allows the user to configure, monitor, and troubleshoot the wireless network in real time without the need of additional software or a server. The unit comes with a built-in spectrum analyzer, a real-time bandwidth monitoring tool, and a wizard to facilitate the configuration of the system.

### AES-128 Encryption Support (FIPS-197 Compliant)

The Fluidmesh MITO Series includes support for 128 bit AES Encryption at the link-level which can be used for FIPS-197 compliance. Because AES is implemented in hardware, there is no loss in terms of performance when AES is enabled.

### Simple Network Management Protocol (SNMP) Support

The Fluidmesh MITO Series supports SNMP version 3. The Simple Network Management Protocol allows the user to centrally manage the mesh devices with a SNMP server and to receive automatic alarms in case of network failure.

# The Fluidmesh Mito Series

## Fluidmesh 1100 with MITO Technology

### RADIO

- Frequency Bands: 5.15-5.25 and 5.725-5.825 GHz (US, FCC)  
5.470 - 5.725 GHz (Europe, ETSI)  
4.940 - 4.990 GHz (US, FCC)
- Modulation: OFDM (BPSK, QPSK, 16-QAM, 64-QAM)
- Modulation speed: Up to 300 Mbps
- TX Power: 27 dBm / 500 mW, depending on configuration and regulatory constraints
- RX Sensitivity 5GHz: -96dB@6.5Mbps; -75dB@300Mbps
- Antenna Type: 2x2 MIMO
- Antenna Gain: 14.6-16.1 dBi
- Antenna Polarization: Dual Linear
- Cross-pol Isolation: 22dB minimum
- Max VSWR: 1.6:1
- Horizontal Coverage: 40 degrees
- Vertical Coverage: 15 degrees
- Elevation Beamwidth: 15 deg.

### ELECTRICAL

- Power input: Passive POE from 12V DC to 24V DC
- Power consumption: Max 8W
- Power over Ethernet Injector: Included, 90/260V 50/60 Hz AC input

### ENVIRONMENTAL

- Operating Temperature: -30°C to +80°C
- Storage Temperature: -30°C to +80°C
- Humidity: 95% condensing
- Weather Rating: IP65
- Wind Survivability: 120 mph
- Shock & Vibration: ETSI 300-019-1.4
- Wind Loading @ 125 mph < 25lb

### PHYSICAL

- Interfaces: Two (2) Internal Ethernet  
10/100BaseT autosensing, RJ45
- Dimensions (mm): 294 (h) x 80 (w) x 30(d)
- Weight (Kg): 0.4
- Enclosure material: Outdoor UV Stabilized Plastic

### OPTIONAL SOFTWARE PLUG-INS

- Ethernet Capacity Plug-in up to 1 Mbps (included)
- Ethernet Capacity Plug-in up to 2.5 Mbps
- Ethernet Capacity Plug-in up to 5 Mbps
- Ethernet Capacity Plug-in up to 10 Mbps
- Ethernet Capacity Plug-in up to 30 Mbps
- Ethernet Capacity Plug-in up to 60 Mbps
- Unlimited Wired Ethernet Capacity Plug-in (up to 100 Mbps)
- 802.1Q VLAN Support
- AES-128 Encryption

## MITO Series General Characteristics:

### NETWORK

- Protocols: UDP, TCP, IP, RTP, RTCP, RTSP, HTTP, HTTPS, ICMP, ARP
- Medium Access Control (MAC) Protocols: Centralized  
Polling-based, Distributed CSMA/CA-based
- Web-based interface for remote management
- Multicast support
- UPnP support
- SNMP support
- 802.1Q VLAN Support

### SECURITY

- Full VPN compatibility
- Full compatibility with all encryption and authentication standards (AES, 3DES, RSA, HTTPS, SSL, etc.)
- AES-128 (FIPS-197 Compliant) Link-level Encryption



Copyright © 2005-2011 Fluidmesh Networks, LLC. All rights reserved. Fluidmesh is a registered trademark of Fluidmesh Networks, LLC. EasyMesh, FMQuadro, FluidMAX and FluidThrottle are trademarks of Fluidmesh Networks, LLC. All other brand or product names are the trademarks or registered trademarks of their respective holder(s). Information contained herein is subject to change without notice. The only warranties for Fluidmesh Networks products and services are set forth in the express warranty statements accompanying such products and services. Nothing herein should be construed as constituting an additional warranty. Fluidmesh Networks shall not be liable for technical or editorial errors or omissions contained herein.

## Fluidmesh 3100 with MITO Technology

### RADIO

- Frequency Bands: 5.15-5.25 and 5.725-5.825 GHz (US, FCC)  
5.470 - 5.725 GHz (Europe, ETSI)  
4.940 - 4.990 GHz (US, FCC)
- Modulation: OFDM (BPSK, QPSK, 16-QAM, 64-QAM)
- Modulation speed: Up to 300 Mbps
- TX Power: 27 dBm / 500 mW, depending on configuration and regulatory constraints
- RX Sensitivity 5GHz: -96dB@6.5Mbps; -75dB@300Mbps
- Antenna Type: 2x2 MIMO
- Antenna Gain: 16.1-17.1 dBi
- Polarization: Dual Linear
- Cross-pol Isolation: 22dB minimum
- Max VSWR: 1.5:1
- Horizontal Coverage: 90 degrees
- Vertical Coverage: 8 degrees
- Elevation Beamwidth: 8 deg.

### ELECTRICAL

- Power input: Passive POE from 12V DC to 24V DC
- Power consumption: Max 8W
- Power over Ethernet Injector: Included, 90/260V 50/60 Hz AC input

### ENVIRONMENTAL

- Operating Temperature: -30°C to +75°C
- Storage Temperature: -30°C to +75°C
- Humidity: 95% condensing
- Weather Rating: IP65
- Wind Survivability: 120 mph
- Shock & Vibration: ETSI 300-019-1.4
- Wind Loading @ 125 mph < 25lb

### PHYSICAL

- Interfaces: One (1) Internal Ethernet  
10/100BaseT autosensing, RJ45
- Dimensions (mm): 370 (h) x 80 (w) x 70(d)
- Weight (Kg): 1.6
- Enclosure material: Anodized Aluminum

### OPTIONAL SOFTWARE PLUG-INS

- Ethernet Capacity Plug-in up to 10 Mbps (included)
- Ethernet Capacity Plug-in up to 30 Mbps
- Ethernet Capacity Plug-in up to 60 Mbps
- Unlimited Wired Ethernet Capacity Plug-in (up to 100 Mbps)
- 802.1Q VLAN Support
- AES-128 Encryption

### APPROVALS

- FCC CFR 47 Part 15, class B
- Industry Canada RSS 210
- CE!

### SUPPLIED ACCESSORIES

- POE Injector 24VDC with US/EU/UK Power Cord
- Pole Mounting Kit (i.e. Pole Mounting Kit Max O.D. 2 in.)

### WARRANTY

- Two (2) years on parts and labor
- Three (3) years optional extended warranty plan with advanced replacement
- Five (5) years optional extended warranty plan with advanced replacement

Fluidmesh Networks LLC  
1359 Barclay Boulevard  
Buffalo Grove, IL 60089  
Phone - (617) 209-6080  
Fax - (866) 458-1522

www.fluidmesh.com  
info@fluidmesh.com

EMEA Headquarters (Italy)  
Tel. +39.02.0061.6189

UK Branch  
Tel. +44.2078.553.132

PERU Branch  
Tel. +51981425057

# NVR 20

## 8 or 16 IP Channel Network Video Recorder

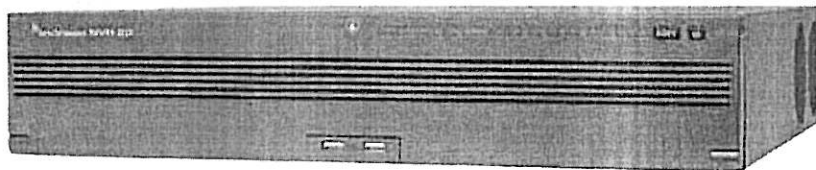

### OVERVIEW

The TruVision™ NVR 20 (TVN 20) is a network video recorder designed to support video streams from IP video cameras. IP camera support includes resolutions from standard resolution to 5 Megapixel from Interlogix and third party IP camera manufacturers. The NVR 20 also supports the Interlogix UltraView™ Encoder 10 H.264 for integrating existing analog cameras.

Up to 8 or 16 video inputs may be configured and internal hard drive capacity ranging from 2TB-16TB makes the TVN 20 ideal for extended storage or megapixel camera applications. Additionally, hard drives may be configured to provide redundant recording for multiple cameras.\*

Recording options include Continuous, Motion, and Alarm or combined scheduled recording modes. Motion recording utilizes an IP camera's built-in motion detection events. Alarms can be triggered from any of the 16 on-board alarm inputs or from alarm inputs that reside on the IP camera.

Software connectivity allows remote access to the full capabilities of the recorder via Web browser or TruVision Navigator. The TVN 20 is easy to configure through IP device auto-discovery tools, and embedded processor technology allows device administration as a network appliance.

\*Support from 3rd party IP cameras may vary.

### STANDARD FEATURES

#### IP Camera Support

- Up to 8 or 16 IP cameras based upon model
- CamPlus™ 2 IP, UltraView IP plus TruVision 1.3 and 2.0 megapixel cameras
- H.264 Axis, Arecont, ACTi and other IP camera manufacturers (VGA and Megapixel)
- UltraView Encoder 10 Single-channel H.264 Encoder

#### Recording Capabilities

- Continuous, Motion or Scheduled recording modes
- Event recording based upon native IP camera activity detection or via unit alarm input
- Video is stored in the native IP camera format
- Audio recording with capable IP cameras
- Redundant camera recording or independent storage groups for different durations

#### Hardware

- Compact rack mountable – 2 RU
- Up to 16TB of internal storage front accessible drives
- GB ethernet connectivity
- 16 on-board alarm inputs and 4 configurable alarm outputs
- Local USB archiving

#### Simple to configure and install

- TruVision device finder (discovery of select TruVision DVRs/NVRs and IP cameras)
- IP Camera auto-discovery in TVN 20 browser
- Configuration and viewing via TVN 20 browser or TruVision Navigator software
- No IP camera licensing

## Specifications

Physical	
Dimensions (W x H x D)	17.72 x 17.72 x 3.74 in. (450 x 450 x 95mm)
Weight	8-Ch 2TB: 21.98lbs (9.97kgs); 8-Ch 8TB: 26.61lbs (12.07kgs); 16-Ch 4TB: 23.52lbs (10.67kgs); 16-Ch 16TB: 32.78lbs (14.87kgs)
Input Voltage	100-240VAC, 6.3A, 50-60Hz
Power Consumption	8-Ch 2TB (8-IP Cameras) to 16-Ch 16TB (16 IP Cameras): 29.07W to 57.67W
Operating Temperature	32°-104°F (0°-40°C) 10-90% Humidity (non-condensing)
Hard Drives	8-Ch: 1, 2, 4 HDD SATA @ 2TB per drive 16-Ch: 2, 4, 8 HDD SATA @ 2TB per drive
Mounting	Rack Mount 19" – 2U (rack mount ears included)

Network & Connectors	
Type	10/100/1000 Base-T, RJ-45
Protocol	TCP, IP, UDP, ARP, RARP, PPP, PPPoE, DHCP, SNMP
Alarm Input	16 programmable NO/NC (Rear)
Alarm Output	4 Form C Relay (Rear)
USB	USB 2+, (2) Unit Front – for local archive-off
eSATA	Future Use (Rear)
RS-232	RJ-45 (Troubleshooting Only)
RS-485	Future Use (Rear)
Audio	No Connectors – from IP Camera (record only, if supported)

Video & Record Parameters	
# of Channels	8 or 16-Channel (based upon model)
Supported IP Compression	H.264, MPEG4 (depending on supported IP camera models)
Supported Resolutions	4CIF, VGA, SVGA, XGA, SXGA, UXGA, QXGA (depending on supported IP camera model)
Recording Modes	Continuous, Motion Activated or Scheduled (Motion activated recording based upon internal IP camera activity detection for supported models)

Miscellaneous	
NVR 20 Operating System	Linux
Health Monitoring	Various conditions including: HDD Fault/Failure, IP Address Conflicts, IP Camera Off-Line Notification, HDD Read/Write Failures, Network Fault
User Rights	3-Levels: Administrator, Operator, Guest
Remote Browser PC Requirements	<p><b>Processor:</b> Intel E6550 Dual Core 2.33 Ghz, 4MB Cache (Minimum); Intel i5 750 Quad Core 2.66 Ghz, 8MB Cache (Recommended)</p> <p><b>Memory:</b> 1GB RAM (Minimum) 4GB RAM (Recommended)</p> <p><b>Graphics Card:</b> HD Video with 256 MB HD Video with 1GB</p> <p><b>Operating System:</b> Windows 2000, Windows XP, Windows Vista</p> <p><b>Browser Environment:</b> Internet Explorer 6+ (ONLY – Internet Explorer)</p>

IP Camera Support – Refer to TVN 20 IP Camera Compatibility Chart for latest updates	
Interlogix	CamPlus™ 2, UltraView™ Encoder 10, UltraView IP, TruVision™ 1.3/2.0 MpX
Axis	216MFD, M1114, M3011, M3014, P1346E, P3301 (ONVIF), P3304 (ONVIF), P3343 (ONVIF), P3344 (ONVIF)
Arecont	AV1305, AV1315, AV1355, AV2105DN, AV2155, AV2805DN, AV2815, AV3105, AV3155, AV5105, AV5155
ACTi	TCM4301, TCM5311, TCM5611, TCM7411
Panasonic	NS201A, NS954, WV-NF285, WV-NP244, WV-NW484S

## Typical capacity configurations

Examples For A Single Type of Camera	Model	
	16 channel	8 channel
Max # of cams using VGA/4CIF only	16	8
Max # of cams using 1.3Mpx only	8	4
Max # of cams using 2.0Mpx only	4	2
Max # of cams using TruVision 2.0Mpx only	8	4
<b>Recommended Storage*</b>		
10 days	4TB	2TB
20 days	8TB	4TB
40 days	16TB	8TB

Examples for Mixed Camera Types-Standard Definition and 1.3Mpx Cameras	Model													
	16 channel							8 channel						
# of VGA/4CIF cams/encoders	16	14	12	10	8	6	4	2	0	8	6	4	2	0
# of 1.3Mpx cams	0	1	2	3	4	5	6	8	8	0	1	2	3	4
<b>Total Cameras</b>	<b>16</b>	<b>15</b>	<b>14</b>	<b>13</b>	<b>12</b>	<b>11</b>	<b>10</b>	<b>10</b>	<b>8</b>	<b>8</b>	<b>7</b>	<b>6</b>	<b>5</b>	<b>4</b>
<b>Recommended Storage*</b>														
10 days	4TB							2TB						
20 days	8TB							4TB						
40 days	16TB							8TB						

Examples for Mixed Camera Types-Standard Definition and 2.0Mpx Cameras	Model								
	16 channel					8 channel			
# of VGA/4CIF cams/encoders	16	12	8	4	0	8	4	0	
# of 2.0Mpx cams**	0	1	2	4	4	0	1	2	
<b>Total Cameras</b>	<b>16</b>	<b>13</b>	<b>10</b>	<b>8</b>	<b>4</b>	<b>8</b>	<b>5</b>	<b>2</b>	
<b>Recommended Storage*</b>									
10 days	4TB					2TB			
20 days	8TB					4TB			
40 days	16TB					8TB			

\*Storage estimates based on settings below and may vary by actual configuration and installation.

VGA/4CIF      25fps/30fps, Bit Rate: 2Mbps  
 1.3 Mpx        25fps/30fps, Bit Rate: 4Mbps  
 2.0 Mpx        12.5fps/15fps, Bit Rate: 2Mbps

**Additional performance possible when using TruVision 2.0 Mpx Cameras	Model								
	16 channel					8 channel			
# of 2.0Mpx cams 12.5 fsp/15fps or fewer, Bit Rate : 4 Mbps	0	2	4	6	8	0	2	4	

# NVR 20

8 or 16 IP Channel Network  
Video Recorder

North America  
T 888-437-3287

Asia  
T 852-2907-8196  
F 852-2142-5063

Australia  
T 61-3-9239-1200  
F 61-3-9239-1299

Europe  
T 32-2-725-1120  
T 32-2-721-4047

Latin America  
T 561-998-6100  
T 561-994-6572

## Ordering Information

TVN-2008-2T	TruVision NVR 20: 8-Ch IP Camera Network Video Recorder, 2TB Storage
TVN-2008-4T	TruVision NVR 20: 8-Ch IP Camera Network Video Recorder, 4TB Storage
TVN-2008-8T	TruVision NVR 20: 8-Ch IP Camera Network Video Recorder, 8TB Storage
TVN-2016-4T	TruVision NVR 20: 16-Ch IP Camera Network Video Recorder, 4TB Storage
TVN-2016-8T	TruVision NVR 20: 16-Ch IP Camera Network Video Recorder, 8TB Storage
TVN-2016-16T	TruVision NVR 20: 16-Ch IP Camera Network Video Recorder, 16TB Storage

## Dimensional Diagram

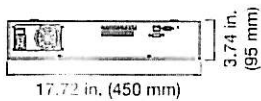
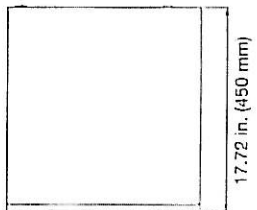

Specifications subject to change without notice.

© 2011 Interlogix, A UTC Fire & Security Company.  
All rights reserved.

106-3435 2011/07 (66641)



interlogix.com  
utcfireandsecurity.com

## HD55IP

www.honeywellvideo.com

### HIGH DEFINITION 720p VFAI LENS DAY/NIGHT H.264 RUGGED INDOOR/OUTDOOR MINIDOME IP CAMERA

Honeywell's latest addition to the Performance Series of IP-based products, the HD55IP is a 720p resolution, day/night rugged indoor/outdoor fixed minidome network camera engineered to provide extremely crisp images at minimal bandwidth. The HD55IP provides 720p resolution at full frame rate. Progressive scan technology and 2D edge enhancement provide outstanding clarity and definition. Digital Noise Reduction results in significant storage savings without sacrificing image quality in low light. The 1/4" progressive scan CMOS sensor offers the latest in digital video surveillance technology with accurate color rendition under a wide variety of lighting conditions. The HD55IP also supports the PSIA specification for interoperability between network video products.

The HD55IP integrates a camera and lens in an ultra compact, single piece, vandal-resistant unit for fast and easy installation in any application. The camera is designed to be surface mounted. Wall and pendant mount kits are also available.

A 3D axis gimbal capable of 360° of pan, 180° of tilt and 360° of horizontal rotation simplifies mechanical camera adjustment. The varifocal auto iris lens allows the field of view to be adjusted to suit the scene requirements, and an integrated analog output is provided for the installer to connect to a local test monitor while adjusting the scene.

A powerful and intuitive web client allows fine tuning of the camera and the auto iris levels.

The HD55IP supports dual video streams and multiple compression formats with rates up to 30 frames per second (25 fps for PAL systems). The digital compression parameters for the two video streams are independently configurable. The primary stream is dedicated to H.264. The secondary stream can be configured for H.264 or MJPEG. A third analog stream can be utilized as backup or for local viewing. It is also valuable when retrofitting onto an existing analog input DVR or encoder (full resolution not available).

With built-in low current Power over Ethernet (IEEE 802.3af), Class 1, power is supplied to the camera using standard network cabling, eliminating the need for a separate power supply and associated wiring. In retrofit situations where PoE switching does not exist, the unit can also be powered directly from 24 V AC.

#### Market Opportunities

The HD55IP is perfect for installations where excellent picture clarity at minimal bandwidth is required. At three times the resolution of standard analog cameras, yet with similar bandwidth requirements, the HD55IP can be retrofitted on many existing DVR/NVR installations without requiring additional storage. Its discreet, vandal-resistant, outdoor design is impact resistant and offers maximum protection against dust, dirt, and water. This provides optimum performance for both indoor and outdoor applications.

#### Key Benefits

- Outstanding image quality, 720p (1280 x 720) resolution
- 30 fps (25 fps PAL) progressive scan
- Day/Night, 3.3-12 mm VFAI lens
- Camera tamper detection
- Video motion detection
- PSIA support
- Dual digital video streams, independently configurable, H.264 and/or H.264/MJPEG
- Remote firmware updates
- Supports both dynamic and static IP address assignment
- Single model for surface mount applications
- Includes advanced IP locator software to make system setup easy
- Web server for remote setup of camera video and network parameters
- Choice of 24 V AC or PoE IEEE 802.3af Class 1 power inputs
- Rugged polycarbonate dome
- Wall and pendant mount kits available



HD  
PSIA



# HD551P

www.honeywellvideo.com

## SPECIFICATIONS

Like all cameras in the Performance Series, the HD551P network camera uses Honeywell technology for camera video motion detection, tamper detection, remote firmware updating and for secure storage of all camera settings. Video motion detection recognizes object motion within the field of view then a simple on-screen notification alerts the user. Camera tamper detection notifies the user when a camera's field of view is altered, blinded, or blurred. This ensures the video's integrity and alerts the customer to either a live event or a system problem that is causing disruption to the video stream. Honeywell's technology also allows users to remotely upload firmware to the camera. Setup is quick and easy and can be customized through a web client or from an NVR or DVR. The built-in web server provides password-protected access to the camera's video and network setup.



### System Diagram

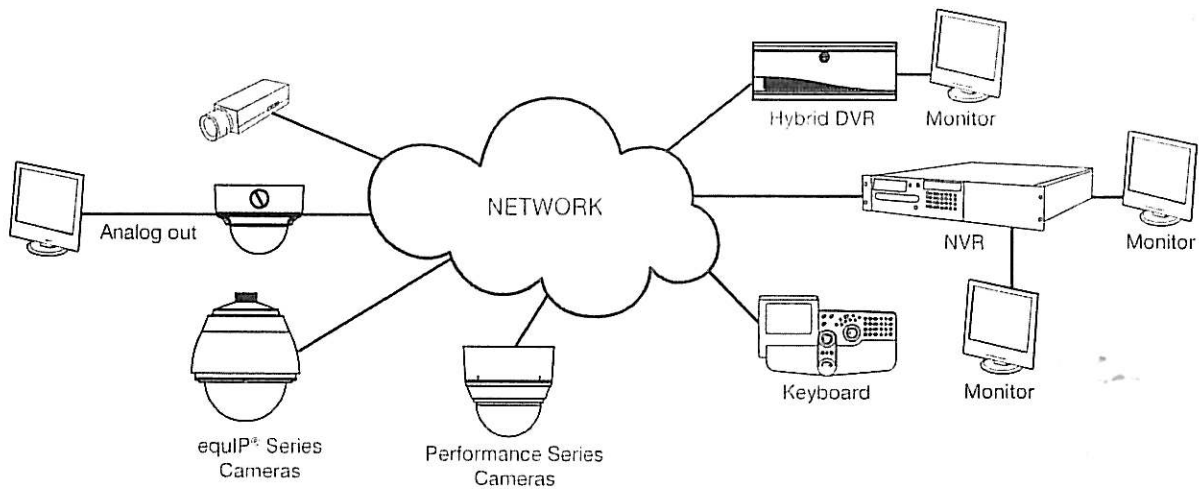

# HD55IP

www.honeywellvideo.com

## SPECIFICATIONS

Operational	
Video Standard	NTSC, PAL
Scanning System	Progressive scan
Image Sensor	1/4" CMOS
Number of Pixels (H x V)	1280 x 720
Minimum Illumination	0.25 lux @ 50 IRE, F1.6 0.11 lux @ 30 IRE, F1.6
Automatic Lens Control	DC Iris Level 1-25
Video Output (Aux)	1.0 Vp-p @ 75 ohms
S/N Ratio	50 dB or more (AGC off)
Auto Gain Control	Off/On, selectable (10-40 dB)
Automatic Electronic Shutter	1/60-1/24,500 sec (NTSC) 1/50-1/24,500 sec (PAL)
Lens Type	3.3-12 mm Varifocal Auto Iris, F1.6
White Balance	AWC, AWC Push, Manual
Electrical	
Input Voltage	24 V AC, PoE IEEE 802.3af, Class 1
Input Range	17-28 V AC
Surge Suppression	1.5 kW transient
Power Consumption	3.5 W (max)
Mechanical	
Dimensions (W x H)	6.1" x 4.6" (154.9 mm x 117.1 mm)
Weight	3.0 lb (1.3 kg) camera only
Construction	Housing: Die cast Aluminum Finish: Cool Gray Powder Coat Dome: Polycarbonate
Connector	Video Output (AUX): 2-pin Molex connector Power Input: Removable screw block Network: RJ45 connector

Environmental			
Temperature	Operating: -4°F to 122°F (-20°C to 50°C) Storage: -40°F to 158°F (-40°C to 70°C)		
Relative Humidity	0% to 85%, non-condensing		
Rating	IP66		
IP Specifications			
Video Compression	Dual stream H.264 and MJPEG		
Resolutions	H.264 Bitrate (Typical)*	Frame Rate	Storage/Day (GB)
1280 x 720	1.8 Mbps	30/25	18.98
800 x 450	1.2 Mbps	30/25	12.65
640 x 360	0.6 Mbps	30/25	6.33
320 x 180	0.21 Mbps	30/25	0.89
Frame Rate NTSC/PAL	Up to 30/25 fps video in all resolutions		
Video Streaming	Dual streaming: H.264 and MJPEG. Controllable frame rate and bandwidth. Constant or variable bit rate		
Security	Multiple user access levels with password protection		
Video Access from Web Browser	Full control of all camera settings, available to administrator		
Minimum Web Browsing Requirements	Pentium IV CPU 3.1 GHz or faster 1 GB RAM (32-bit) or 2 GB RAM (64-bit) Windows XP SP3, Windows 2003 Server R2 (32-bit), Windows 7 (32-/64-bit), Windows 2008 Server (32-/64-bit), Windows 2008 R2 (64-bit) Internet Explorer 6, 7, 8, or 9		
Installation and Management Maintenance	Honeywell IP Utility software identifies the IP address, checks status of device, firmware upgrades over HTTP		
Supported Protocols	HTTP, TCP, RTSP, RTP, UDP, ARP, DNS, RTCP, FTP, ICMP, DHCP, Bonjour, IGMP, Telnet		
Standards	PSIA support		
Regulatory			
Emissions	FCC, CE (EN55022)		
Immunity	CE (EN55024)		
Safety	EU: EN60950-1 North American ETL listed to UL/CSA 60950-1		

\*Actual bitrate is scene and motion dependent

# HD55IP

www.honeywellvideo.com

## SPECIFICATIONS

System Integration
<b>Open IP Integration</b>
PSIA support and open API for real interoperability between Honeywell and other manufacturers' IP-enabled security devices. Refer to the Honeywell Open Technology Alliance ( <a href="http://www.security.honeywell.com/hota/">http://www.security.honeywell.com/hota/</a> ) to learn more about our open and integrated solutions.

Accessories	
Housing and Mounts	
HD4CHIP-PK	Pendant Mount Bracket
HD4CHIP-WK	Wall Mount Bracket

HD55IP Dimensions

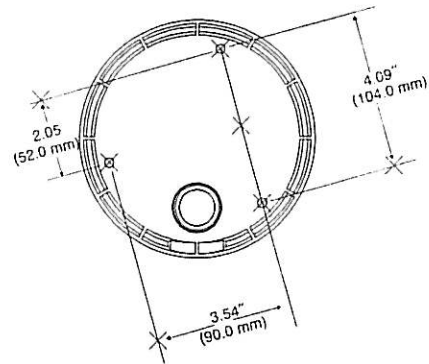
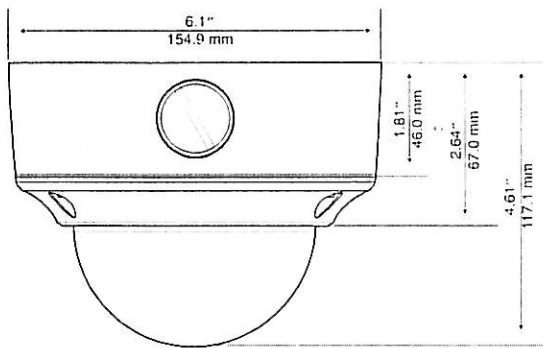

HD4CHIP-PK Pendant Mount

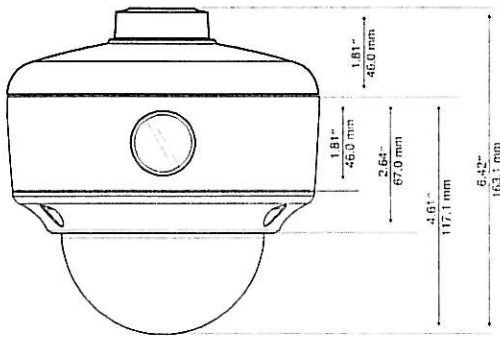

HD4CHIP-WK Wall Mount

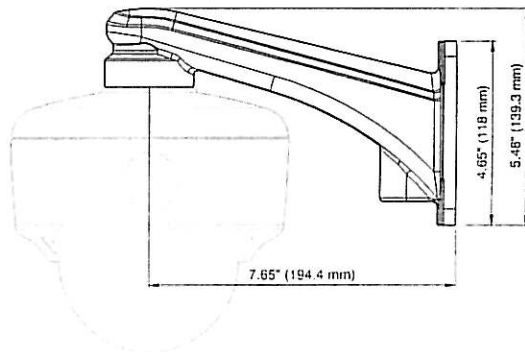

Ordering	
HD55IP	Network, Day/Night Rugged Fixed Minidome Camera, 1/4" Progressive Scan, CMOS, 720p Resolution, 3.3-12 mm VFAI Lens, 24 V AC or PoE IEEE 802.3af Class 1, H.264, NTSC
HD55IPX	Network, Day/Night Rugged Fixed Minidome Camera, 1/4" Progressive Scan, CMOS, 720p Resolution, 3.3-12 mm VFAI Lens, 24 V AC or PoE IEEE 802.3af Class 1, H.264, PAL

NOTE: Honeywell reserves the right, without notification, to make changes in product design or specifications.

Automation and Control Solutions  
 Honeywell Systems  
 2700 Blankenbaker Pkwy, Suite 150  
 Louisville, KY 40299  
 1.800.323.4576  
 www.honeywell.com

LHD55IP-D  
 December 2012  
 © 2011 Honeywell International Inc.

# CCTV SYSTEM QUOTES

GOOD

BETTER

BEST

Submitted By:

Kelly Sullivan, MidCo, Inc.

March 27, 2013

# CCTV SYSTEM QUOTES

PROPOSED BY:

MIDCO, INC.

221 SHORE COURT

BURR RIDGE, IL 60527

PREPARED FOR:

THE VILLAGE OF DARIEN PUBLIC  
WORKS

1041 S. FRONTAGE ROAD

DARIEN, IL 60561

**1**

CCTV System Quote - Good Solution

**2**

Good Solution Product Cut Sheets

**3**

CCTV System Quote - Better Solution

**4**

Better Solution Product Cut Sheets

**5**

CCTV System Quote - Best Solution

**6**

Best Solution Product Cut Sheets

**7**

Lightening Protection Cut Sheets

**8**

Bridge Access Point Cut Sheets



# CCTV System Quote

## Good Solution



# MidCo Inc. Proposal

MidCo Inc.  
 16W221 Shore Court  
 Burr Ridge, IL 60527  
 www.midcosystems.com

<b>Purchaser:</b>	City of Darien Public Works	<b>Quote Date:</b>	March 27, 2013
<b>Address:</b>	1041 S. Frontage Road Darien, IL (630) 353-8104	<b>Prepared By:</b>	Kelly Sullivan
<b>Phone:</b>		<b>E-Mail:</b>	ksullivan@midcosystems.com
<b>Fax:</b>		<b>Proposal #:</b>	132703KS-1
<b>Prepared For:</b>	Scott Coren	<b>E-Mail:</b>	scoren@darienil.gov

**Project:** CCTV System-Good **Total:** \$30,210.00  
 Tax Not Included

Qty	Mfg.	Part No.	Description
-----	------	----------	-------------

**CCTV System  
(Good)**

1	Exacq	1608-48-4000-DT	4 TB Hybrid Unit
2	Cisco	SRW208MP-K9-NA	8 Port POE Managed Switch
2	Pelco	MCS8-5	Camera Power Supplies

Cameras #1,4,5

3	Clinton	CE-VF1000-IR	Fixed IR Bullet Camera
---	---------	--------------	------------------------

Camera #2-License Plate

1	Arecont	AV3116DNv1	WDR 3 Megapixel Day/Night Camera
1	Arecont	HSG2	Outdoor Housing
1	Arecont	HSG2-WMT	Wall Mount for Housing
1	Arecont		Fujinon Zoom Lens
	Arecont	VIS-1040-S850-1	IR Unit
	Arecont	VIS-60-PWRS	Power Supply for IR Unit

Camera #3

1	Arecont	3255AM-IR-H	3 Megapixel Day/Night Camera
1	Arecont	MD-WMT2	Wall Mounts
1	Arecont	MD-CRMA	Corner Mounts

1	MidCo	Programming	Technical Support and Programming
1	MidCo	Drawings	Drafting and AutoCAD
1	MidCo	PM&ENG	Project Management and Engineering
1	MidCo	Training	Training
1	MidCo	Miscellaneous	Miscellaneous Connectors and Installation Material
1	Cable	1 Lot	Device Cabling

Price includes applicable installation labor unless otherwise noted. Price is exclusive of all conduit and electrical boxes. Our proposal includes adequate labor to connect, program and test circuits with your system. Troubleshooting network problems caused by 3rd party suppliers is not included with this proposal. Additional labor hours that are required as a result of the non-performance of these 3rd party devices will be invoiced at our prevailing rate.

Purchaser acknowledges receipt of MidCo's Terms and Conditions and Project Qualifications documents, understands them, and agrees to be bound by its provisions. Further, the purchaser agrees that it is the complete and exclusive statement of the agreement between the parties which superseded all proposals or prior agreements oral or written. Your sales price has a 4% cash payment discount included. If you would prefer to pay by credit card 4% will be added to your quoted purchase price.

MidCo Inc. Signature _____	Signature of Purchaser _____
Date _____	Date _____

This proposal valid for 15 days from Date of Proposal

Page 1 of 2

Phone # (630) 887-1800 - Fax# (630) 887-1962





# MidCo Inc. Proposal

MidCo Inc.  
 16W221 Shore Court  
 Burr Ridge, IL 60527  
 www.midcosystems.com

<b>Purchaser:</b>	City of Darien Public Works	<b>Proposal Date:</b>	March 27, 2013
<b>Address:</b>	1041 S. Frontage Road	<b>Prepared By:</b>	Kelly Sullivan
<b>City, St, Zip</b>	Darien, IL	<b>E-Mail:</b>	ksullivan@midcosystems.com
<b>Phone</b>	(630) 353-8104	<b>Proposal #:</b>	132703KS-1
<b>Fax:</b>		<b>E-Mail:</b>	scoren@darienil.gov
<b>Prepared For:</b>	Scott Coren		

**Project: CCTV System-Good**  
**Page 2**

Qty	Mfg.	Part No.	Description	
-----	------	----------	-------------	--

**NOTES**

Assumes that each building will have a network  
 Customer to provide network connection within 5  
 feet of Headend  
 IP addresses by customer  
 Power for cameras provided by others  
 Lift provided by others  
 Conduit not included  
 Monitors not included-can be added upon request  
 Assumes all work to be completed during normal  
 business hours, Monday-Friday

**OPTIONS**

\* Options include all necessary equipment & labor  
 \* Options not included in total

		<b>Recommended</b>	<b><u>LIGHTENING PROTECTION</u></b>	<b>\$1,538.00</b>
3	Ditek	DTK-PVP27B	Lightening Protection	
2	Ditek	MRJPOE	Lightening Protection	
2	Ditek	DTK-ILVLP-LV	Power Cable Protection	
			<b><u>Wireless Network at Each Building</u></b>	<b>\$1,512.00</b>
2	Engenius	ENH202	Outdoor Bridge	

NOTE: Network will be needed

Price includes applicable installation labor unless otherwise noted. Price is exclusive of all conduit and electrical boxes. Our proposal includes adequate labor to connect, program and test circuits with your system. Troubleshooting network problems caused by 3rd party suppliers is not included with this proposal. Additional labor hours that are required as a result of the non-performance of these 3rd party devices will be invoiced at our prevailing rate.

Purchaser acknowledges receipt of MidCo's Terms and Conditions and Project Qualifications documents, understands them, and agrees to be bound by its provisions. Further, the purchaser agrees that it is the complete and exclusive statement of the agreement between the parties which superseded all proposals or prior agreements oral or written. Your sales price has a 4% cash payment discount included. If you would prefer to pay by credit card 4% will be added to your quoted purchase price.

MidCo Inc. Signature _____	Signature of Purchaser _____
Date _____	Date _____



**Project Qualifications**  
**City of Darien Public Works - CCTV System-Good**

Included by MidCo	Not Incl. by MidCo	Item Description
	x	Supply A.C. Power from Breakers to Security Panel
	x	Supply A.C. Power, up to 25' to Security Panel
	x	Electrical Earth Ground
	x	Conduit with Pull string
	x	Conduit Stubs
	x	Painting of Exposed Electrical Conduit
	x	WireMold for Exposed Cabling
x		Standard Back boxes
	x	Special Back boxes
	x	Lighting / Surge protection
	x	Door Locking Hardware/Mechanisms
	x	Door Hardware Power (up to 0.33 amps per lock)
	x	UPS Emergency Power Source
	x	Man Lifts
	x	Job Trailer or Job Storage Gang box
	x	MidCo Inc. Standard Insurance
	x	Teleo / Data Closet Plywood Backboards
	x	Patching / Painting
	x	Ceiling Tile Removal/Replacement
	x	Performance and Payment Bond
	x	Required Permits and any additional Fee's
	x	Liquidated Damages
	x	Consequential Damages
	x	Any asbestos inspection or removal costs of any kind
	x	Based the pre-billing for items like Turnstiles, Gates, etc. to meet manufacture or supplier terms and conditions
	x	Minimum costs for add's, moves and changes on construction jobs of 10% overhead and 10% profit.
x		Subject to Site Testing and Conditions

Included by MidCo	Not Incl. by MidCo	Item Description
x		Plenum Cable
	x	PVC Cable
x		Wire Labels (For MidCo Supplied Cable)
	x	Abandoned Cable Removal
x		System Server - HDVR
	x	Client Workstation(s) - Computer Hardware
	x	Network Interface Units
x		Hubs / Routers/ Switches
	x	Fire alarm Relays as needed from building FAS vendor
	x	Cable from Fire Panel to Fire Relay
	x	Elevator cabling
	x	Security Console Cabinetry
x		Project Management
x		Training - up to 4 Hours
	x	Premium Time Work
x		Escorted System Testing ( 1 test)
x		System Drawings (Block Diagram)
	x	Panel (Typical Wiring) Drawings
	x	Device (Typical Wiring) Drawings
	x	Floor plans with Device Locations.
	x	Out of Town Travel,Hotel,Per Diem,Car Rental
	x	Freight
	x	Estimated Taxes

By Cust. YES	By Cust. NO	CUSTOMER SUPPLIED ITEMS Please fill out if applicable
x		Static IP addresses if needed
x		Alarm dedicated phone line
x		Customers Network Equipment

**CAD DRAWINGS:** In order for MidCo to supply system drawings or floor plan device layouts, AutoCAD backgrounds must be furnished to MidCo in file format (\*.dxf / \*.dwg) at no charge to MidCo by owner or owner's representative.

**POWER/GROUNDING and UPS System:** Dedicated, Computer Grade A.C. Power must be available for operation of Security Equipment. Dedicated A.C. circuit(s) must be provided appropriate for the amount of current draw for equipment being installed. Voltage levels and noise immunity must be equal to or better than industry standards and equipment manufacturer requirements. Also, an earth ground connection must be provided for proper grounding at equipment locations. Supplying earth ground from electrical supply is not included, and if needed will be installed on a Time and Material invoice basis. A UPS system is always required on all security panels and head-end computer equipment to maintain the MidCo Inc. warranty negotiated on each project.

**EXISTING DEVICES:** If applicable, existing field devices which are re-used are assumed to be in satisfactory operating condition. Troubleshooting and/or repair of existing devices will be performed by MidCo on a Time and Material invoice basis.

**EXISTING CABLE:** If applicable, existing wire and/or cabling which is re-used is assumed to be in satisfactory operating condition, and of equal or better technical specification than required by the manufacturer of installed equipment. Troubleshooting or replacement of sub-standard wire/cabling will be performed by MidCo on a Time and Material invoice basis.

**VIRUS PROTECTION:** Virus Protection for computer systems is a requirement of the customer, allowing consistency with other customer computer equipment. Routine virus definition updates are the responsibility of the customer. Service calls due to virus created problems are not covered under warranty protection, and will be subject to Time and Material invoicing.

**DATA BACKUP:** MidCo will backup system data at installation completion, and train customer on system data backups. Data re-entry due to lack of backup is not included in warranty coverage, and will be subject to Time and Material invoicing. It is recommended that the customer do periodic system and database backup's on a daily basis if possible.

**OPERATING SYSTEM:** If supplied by MidCo, computer operating system software will be current up to guidelines supplied by the application software manufacturer. Upgrades are the responsibility of the customer, but must be coordinated with MidCo and the application software manufacturer in order to insure application compatibility with operating system upgrades.

Notes:

Customer  
Signature/Date

MidCo Signature/Date

## TERMS AND CONDITIONS

### EXCLUSIVE WARRANTY AND REMEDY

MidCo's exclusive warranty is that Services will be performed in a workmanlike fashion and all parts provided by MidCo shall be free of defects in material and workmanship for a period of one year, or as otherwise stated on the front of this Agreement, from the date of either substantial installation completion, or beneficial use of system, whichever is sooner. MidCo further agrees that all Services performed without furnishing parts shall be free of defects for a period of thirty (30) days, unless otherwise noted. MidCo's warranty period applies during normal business hours, Monday through Friday, 8 a.m. to 4:30 p.m. C.S.T.

**IN THE EVENT MIDCO BREACHES THIS WARRANTY, MIDCO'S SOLE OBLIGATION AND CUSTOMER'S EXCLUSIVE REMEDY, SHALL BE TO HAVE MIDCO MAKE ALL NECESSARY ADJUSTMENTS, REPAIRS, OR REPLACEMENT OF PARTS WHICH WERE DEFECTIVE AT THE TIME OF INSTALLATION.** There are no other express or implied warranties concerning any Service, parts, supplies, or expendable items provided hereunder. MidCo does not guarantee that the operation of the equipment will be uninterrupted or error-free. **MIDCO DISCLAIMS THE IMPLIED WARRANTIES OF MERCHANTABILITY AND FITNESS FOR A PARTICULAR PURPOSE, THE FOREGOING SHALL BE THE SOLE REMEDY OF CUSTOMER FOR BREACH OF WARRANTY.**

### INSTALLATION SERVICES

MidCo will perform the following Services at MidCo's standard charges when installation is specified in this Service Order. MidCo shall install the equipment as listed in accordance with local electrical codes and manufacturer's specifications or as otherwise shown. All work will be completed, unless otherwise agreed to, during Seller's normal business hours. Customer agrees to furnish a dedicated, properly grounded, commercial power circuit.

**THIS AGREEMENT SHALL BECOME NULL AND VOID IF EQUIPMENT IS SERVICED OR RELOCATED BY PARTIES OTHER THAN MIDCO INC. WITHOUT THE WRITTEN CONSENT OF MIDCO INC.**

### ADDITIONAL CHARGES

Services performed as a result of any of the following conditions shall be subject to additional charges for labor, transportation and parts; alterations of equipment not authorized in writing by MidCo; failure of third party circuits; failure of cable, cable plants, or cable infrastructure(s), unless specifically warranted or covered on the face of this Agreement; expendable supply items, damage or failure resulting from improper use, including use by the Customer of any equipment or software in a manner not intended by the manufacturer or MidCo Inc., any acts other acts, events, programming alterations, additions, or deletions, which may adversely effect system integrity or performance, occasioned by the Customer or third-parties; use of third-party equipment in combination with system equipment not otherwise supplied, covered or previously authorized for such use by MidCo Inc. in writing.

Damage resulting from events commonly referred to as "acts of God", including, but not limited to, weather and weather-related damage, lightning strikes, flood damage, water damage, hail, tornado, hurricane, earthquake, fire, acts of terrorism or similar acts, damage resulting from misuse and/or abuse, in-transit damage, accident, neglect, power surge or failure, operating environment, or the use of supplies or accessories which are not in conformance with the equipment manufacturer's published specifications; site surveys; **OR EVENTS OTHER THAN NORMAL WEAR AND TEAR.**

### LIMITATION OF LIABILITY

**IN NO EVENT SHALL MIDCO BE LIABLE IN CONTRACT, TORT OR OTHERWISE FOR INCIDENTAL, CONSEQUENTIAL, SPECIAL OR INDIRECT DAMAGES, INCLUDING WITHOUT LIMITATION, LOST BUSINESS PROFITS NOR DAMAGE OR DESTRUCTION OF DATA EVEN IF IT HAS BEEN ADVISED OF THE POSSIBILITY OF SAME,** except as to personal injury. MidCo's maximum liability shall be limited in any event to the actual direct damages incurred by Customer, which are caused, solely by the acts or omissions of MidCo subject to a maximum liability of the lesser of the amount paid for the services performed under this Service Order (subject to a maximum of one twelve (12) months duration) of \$1,000.00. Customer agrees to provide MidCo with prompt written notification as to the specifics of any claim for damages and to provide MidCo with a reasonable opportunity to investigate. **NO LIMITATION AS TO DAMAGES FOR PERSONAL INJURY IS INTENDED.**

### SECURITY INTEREST

To secure payment and performance of all Purchaser's obligations hereunder. Purchaser hereby grants to Seller a security interest in and to the goods covered by this contract and in and to any additions and accessions thereto provided, never less, that the risk of any loss or damage to the goods shall pass to Purchaser upon shipment to Purchaser or upon delivery to Purchaser's premises, whichever is earlier. Until Seller has been paid in full, Purchaser shall not in any mannered sell, transfer, lease, mortgage or encumber its interest in the goods covered by this contract nor part with possession thereof, without the Seller's prior written consent.

### FORCE MAJEURE

The parties' performance under this Agreement is subject to acts of God, war, government regulation, threats or acts of terrorism or similar acts, governmental travel advisories, disaster, strikes, civil disorder, curtailment of transportation facilities, or any other cause beyond the parties' control, making it inadvisable, illegal or impossible to perform their obligations under the Agreement. Either party may cancel the Agreement for any one or more of such reasons upon ninety (90) days prior written notice to the other.

## PRICES

Prices shall be the price set forth on the face of this Agreement. All sales, property, excise and other federal, state, and local taxes (other than those based upon MidCo's net income), shall be paid by Customer. All invoices are payable within thirty (30) days of the date of the invoice. Customer shall make such arrangements for payment as MidCo may require and MidCo may suspend performance under this Agreement until such arrangements are made.

**PAST DUE AMOUNTS SHALL BE SUBJECT TO AN INTEREST CHARGE OF 1.5% PER MONTH**, or the highest rate permitted by law, plus all costs of collection. MidCo reserves the right to adjust the service charge in conformity with MidCo's standard charges in the event Customer changes the equipment or attaches additional features or equipment to the covered equipment after the date hereof.

## BILLING

Goods covered by this contract will be billed when installed or as otherwise specified. Labor, material and installation will be billed at MidCo's then-current labor rate upon completion of installation or upon the last day of each month in which installation is performed, at Seller's option. Purchaser agrees to pay Seller as follows: 50% down payment with order, 40% upon delivery of equipment and the remaining balance of 10% due net ten (10) days upon completion of installation. Past due amounts will be subject to an interest charge of 1.5% per month, or the highest rate permitted by law, plus all costs of collection. Prices and terms subject to change without notice. No returns will be allowed without written consent of the Seller.

## ENTIRE AGREEMENT

This Service Order Agreement sets forth the entire agreement of the parties with respect to the subject matter hereof and supersedes any prior agreement or negotiation between the parties. There is no other understanding, agreement, presentation, expressed or implied, statutory or otherwise, in any way limiting, extending, defining or relating to the provisions hereof. **NO AGREEMENT ALTERING, MODIFYING, OR EXTENDING THE TERMS OF THIS SERVICE ORDER SHALL BE VALID UNLESS IN WRITING, DULY SIGNED BY BOTH PARTIES HERETO.** The parties expressly acknowledge that they have not relied on any prior or contemporaneous oral or written representations or statements by the other party in connection with the subject matter of this Service Order.

Any term or condition of an offer set forth on any Purchase Order or any other document created by Customer of MidCo, which is inconsistent with any term or condition of this Service Order, shall be of no force or effect whatsoever. **NEITHER CUSTOMER NOR MIDCO SHALL BE BOUND BY ANY ORAL AGREEMENT OR REPRESENTATION IRRESPECTIVE OF BY WHOM OR WHEN MADE.**

## SEVERABILITY

Any provision or provisions of this Agreement which are unenforceable, invalid or contrary to law, or the inclusion of which would affect the validity or enforceability of this Agreement shall be of no force or effect, and in such event each and all of the remaining provisions of this Agreement shall subsist and remain and be fully effective according to the tenor of this Agreement the same as though any such invalid, unenforceable or unlawful provision or provisions had never been included in this Agreement.

## APPLICABLE LAW

This Agreement and each transaction contemplated hereunder shall be deemed to be made under the laws of the State of Illinois and shall be construed in accordance with the laws of said State.

# Good Solution Product Cut Sheets

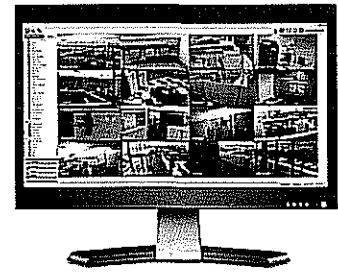
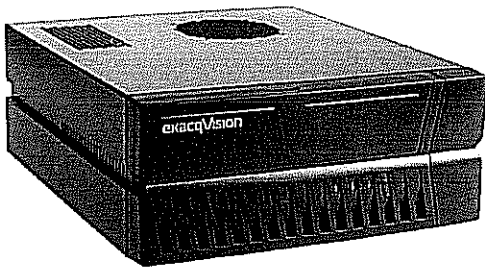

# exacqVision **A-Series**



**Hybrid Desktop**  
*Analog and IP Cameras*

## **exacqVision A-Series Desktop Hybrid Servers** *Compact, Reliable, Professional Grade Hybrid Systems*

### **Key Features & Benefits:**

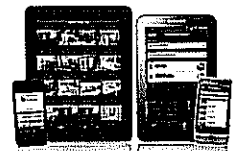
- **True Hybrid** — Seamlessly integrate your existing analog and IP cameras from all of the leading camera vendors onto one server for centralized management. Includes up to 32 IP cameras per server and 64 analog inputs with 8 IP channels.
- **8 IP Camera Licenses Included** — Cost-effective solution providing complete control for multiple servers simultaneously. Add additional IP licenses as needed.
- **Pre-Configured with Intuitive exacqVision Software** — Powerful yet easy-to-use exacqVision VMS client interface operates on Windows, Linux and Macintosh
- **Cross-Compatible Operating System** — A-Series servers are available with Windows or Linux operating system. Easy to use client is available for Windows, Linux and Mac. Servers can also be accessed via any major web browser using the free exacqVision web service. All servers and clients are cross compatible.
- **Complete Solution** — The A-Series desktop hybrid server features an Intel i3 processor to handle server, client and web service applications all from the same unit.
- **3-Year Hardware Warranty, 3-Year Software Subscription Agreement** — Receive quarterly software updates for all the latest advancements as they are released along with access to technical support. IP Camera licenses never expire.
- **Included Mobile App** — Manage and monitor video remotely at any time by downloading the exacq mobile app for iPhone, iPad and Android devices
- **Space-Saving Chassis** — Compact, sturdy chassis easily fits on top of a desk.



Camera, Alarm & Audio Settings	Desktop
IP Cameras	4 or 8 IP licenses included. Expandable to 64 cameras per server (data rate dependent)
IP Compression Format	Camera dependent
Analog Inputs	8/16/32
Analog Outputs	1 mux, BNC
Analog Compression	H.264/MPEG-4/MJPEG
Analog Frame Rate (NTSC)	240/480/960
Analog Frame Rate (PAL)	200/400/800
Serial Connections	RS-485 (PTZ) & RS-232 port
Alarm Inputs	8 TTL
Alarm Outputs	3TTL + 1 relay output
Audio Inputs	8/16/32
Audio Outputs	1
Storage & Memory	
RAM	2 GB (standard), 4 GB (optional)
Drive Bays	2
Storage Maximum (Internal)	Up to 4 TB
Features	
NIC	2
USB2 Ports	8 x USB 2.0
Monitor Output	1 VGA + 1 HDMI 1.4 + 1 DVI-D, maximum 2 simultaneous monitors
Processor	Intel® i3 (standard), Intel® i5 (optional)
Keyboard & Mouse	Included
DVD/CD RW	Included
Watchdog Timer	Included
Server Operating System	Windows 7 Pro on 30 GB HDD Partition or Linux Ubuntu 10.04 (kernel 3.0) embedded on 4GB flash drive
VMS Software Included	exacqVision Professional (standard), exacqVision Enterprise Server (optional)
Compatible Client Operating System	Windows 7, Vista, XP, Server 2003/2008 32-bit or 64-bit Linux (Ubuntu) Mac OS X 
Regulatory	CE (Class A), FCC (Class A), UL Listed
Warranty	3 years, parts & labor plus 3 years SSA included 
Size	
Dimensions (l x w x h)	15.675 x 13 x 5.375 in 39.7 x 33.1 x 14.6 cm
Weight	18.5 – 22 lbs. 8.4 – 10 kg
Requirements	
Operating Temperature	40° – 95°F (4.5° – 35°C)
Relative Humidity	5 – 95% RH (non-condensing)
Input Voltage	120/240 VAC auto-sensing
Power Consumption	<250 Watts (150 watts typical)
Power Cables	North America (standard), UK & EU (optional)

Specifications subject to change. Visit [www.exacq.com](http://www.exacq.com) for the most current product specifications.

Part Numbers	
Model #	Hard Drive
<b>8 Analog Inputs – 240 FPS Models</b>	
0804-24-0500-DT	500 GB
0804-24-1000-DT	1 TB
0804-24-2000-DT	2 TB
0804-24-4000-DT	4 TB
<b>16 Analog Inputs – 480 FPS Models</b>	
1608-48-0500-DT	500 GB
1608-48-1000-DT	1 TB
1608-48-2000-DT	2 TB
1608-48-4000-DT	4 TB
<b>32 Analog Inputs – 960 FPS Models</b>	
3208-96-0500-DT	500 GB
3208-96-1000-DT	1 TB
3208-96-2000-DT	2 TB
3208-96-4000-DT	4 TB



**Exacq Technologies USA**  
11955 Exit Five Parkway  
Fishers, IN 46037 USA

**Exacq Technologies Europe**  
Business & Technology Centre  
Bessemer Drive  
Stevenage, Herts SG1 2DX UK

+1.317.845.5710 USA  
+5255.56080817 Mexico  
+44.1438.310163 UK  
+44.1438.310163 Europe  
+852.8120.9275 Hong Kong

**exacq**<sup>®</sup>  
Technologies  
[www.exacq.com](http://www.exacq.com)

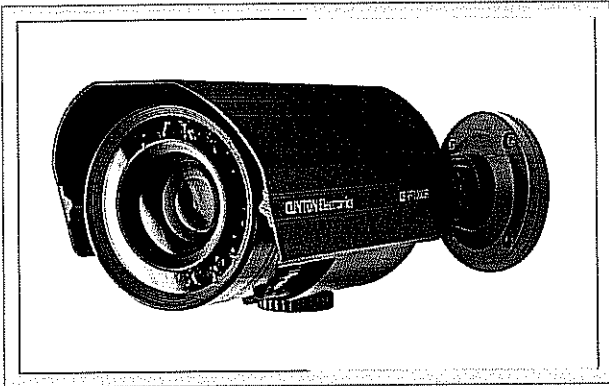
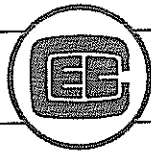

## CE-VF1000IR

### Long Range IR Bullet Camera

- SONY 1/3" CCD (Super HAD)
- 600 TVL Resolution
- 15 Giant IR LEDs (IR LED Adjustment Potentiometer)
- 5 ~ 50mm (F1.2) Lens (Externally Adjustable)
- S5 Digital Signal Processing
- Digital Noise Reduction (DNR)
- Sense Up Feature for Optimal Night Image
- Digital Image Stabilization (DIS)
- High Light Compensation (HLC)
- OSD Menu Control via CE-REMOTE
- Cable Through Bracket Design with Mounting Plate
- Weather Resistant
- DC12V / AC24V

### Dimensions

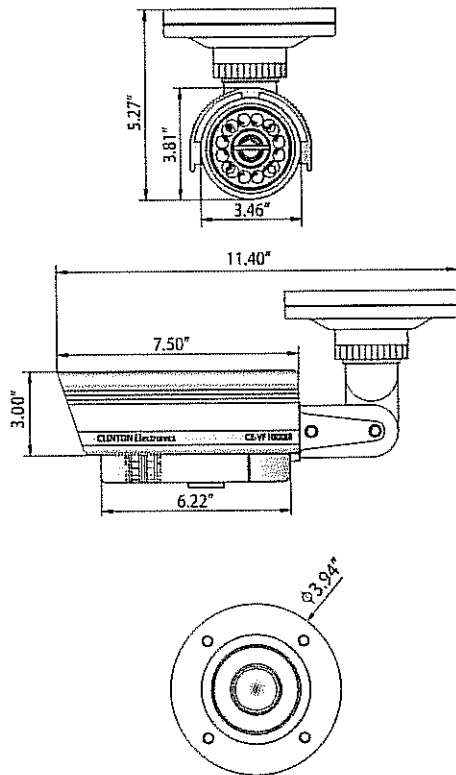

### Specifications

Image Sensor	1/3" CCD (Super HAD)
Resolution	600 TV Lines
IR LEDs	15 pcs of Giant IR LEDs
Effective Pixels	768 (H) x 494 (V)
Scanning System	2:1 Interlace
S/N Ratio	More than 50dB
Sync System	Internal / Line Lock
Scanning Frequency	15.734 KHz (H), 59.94 Hz (V)
Minimum Illumination	IR OFF 0.1 Lux / IR ON 0 Lux
Shutter Speed	1/60 ~ 1/100,000 sec.
Lens	5 ~ 50mm Vari-Focal (Externally Adjustable)
Video Output	1.0 Vp-p, 75Ω
Power Consumption	Max. 920mA (DC12V) with IR LEDs ON Max. 500mA (AC24V) with IR LEDs ON
Power Requirement	DC12V / AC24V
Operating Temperature	-20°F ~ 120°F
Operating Humidity	Within 95% RH
Dimensions	11.4" (L) x 3.94" (W) x 5.28" (H)
Weight	4.4 lbs.
Lens	DC Video
Exposure	Brightness / Shutter / AGC / Sens-Up / Return
White Balance Control	ATW / Manual / AWC->SET / Outdoor / Indoor
SSDR	Off / On
Backlight	Off / BLC / HLC
DNR3	Off / On
Day/Night	Auto / Color / B&W / External
Special	Image Adj / Monitor / Cam Title / Sync / Motion / Privacy / Comm Adj. / Language / Reset
Exit	Save / Not Save / Reset

Information in this document is subject to change

### Recommended Power Supply

CE-T24VAC800	1 Camera 20 watt AC24V
CE-T24VAC2000	1 Camera 50 watt AC24V

All Clinton Multi Camera Power Supplies

### Optional Accessories

#### CE-REMOTE

- Plugs directly into Camera
- Adjusts OSD Functions
- Test Monitor Connection





# AV2116DN/AV3116DN

**Arecont Vision**  
megapixel technology...  
beyond imagination

Full HD 1080p and 3-Megapixel Compact H.264 WDR IP MegaVideo Camera

**AV2116DNv1** Full HD 1080p WDR Day/Night

**AV3116DNv1** 3MP WDR Day/Night



## The True Wide Dynamic Range Camera

WDR up to 100dB Allowing Users to See Clearly in Shaded and Bright Light Conditions Simultaneously

Binned Mode Improves Low-Light Performance in 3MP Versions

## Arecont Vision Advantages:

- True Wide Dynamic Range Control
- True Day/Night Functionality with Removeable IR Cut Filter
- Dual Encoder H.264/MJPEG
- The Fastest Frame Rates on the Market
- Privacy Mask, Motion Detection and Flexible Cropping
- PSIA and ONVIF Conformant
- New User Friendly Web-Page
- Bit Rate Control to Control Bandwidth
- PoE and Auxillary Power: 12-48V DC/24V AC
- Forensic Zooming
- Compact Package



Specification sheets subject to change without notice.

Made in the USA



# AV2116DN/AV3116DN

## Specifications

### Model Numbers

- AV2116DNv1** Full HD 1080p Wide Dynamic Range, Day/Night  
**AV3116DNv1** 3MP Wide Dynamic Range, Day/Night

### Imaging

- 2.07-megapixel effective CMOS image sensor (AV2116)
- 3-megapixel CMOS image sensor (AV3116)
- 1/3.2" optical format
- 2.2 µm pixel pitch
- Progressive Scan
- Minimum illumination of:
  - Color (non-binned): 0.3 Lux @ F1.4
  - Color (binned): 0.15 Lux @ F1.4
  - Day/Night: 0 Lux, IR sensitive
- Wide Dynamic range up to 100 dB
- Maximum SNR 49 dB

### Full Field-of-View (FOV) Resolution

Model Numbers	Full FOV Resolution	1/4 Resolution
AV2116	1080p 1920 (H) x 1080 (V)	960 (H) x 540 (V)
AV3116	3MP 2048 (H) x 1536 (V)	1024 (H) x 768 (V)

### Cropped (FOV) Resolution

Flexible Cropping - Crop to 2 pixels in H.264 and 1 pixel in JPEG

- 1920x1200 WUXG (AV3116)
- 1920x1080 HDTV - 1080p (AV3116)
- 1600x1200 2MP (AV3116)
- 1280x1024 1.3MP
- 1280x720 HDTV - 720p
- 640x480 VGA

### Data Transmission

- Video frame rate up to:
  - 21fps @ 2048x1536 (AV3116)
  - 31fps @ 1600x1200 (AV3116)
  - 30fps @ 1920x1080
  - 41fps @ 1280x1024
- Video frame in binned mode up to:
  - 21fps @ 1024x768 (AV3116)
  - 27fps @ 800x600 (AV3116)
  - 31fps @ 860x540 (AV3116)
  - 32fps @ 640x512 (AV3116)
- Compression type
  - H.264 (MPEG-4, Part 10)/Motion JPEG
  - 21 levels of quality
- TFTP, HTTP, RTSP, RTP/TCP, RTP/UDP image transmission protocols
- 100Base-T Ethernet Network Interface
- Multi-streaming: 8 non-identical streams

### Electrical

- General purpose opto-coupled input and output
- Power over Ethernet (PoE): PoE 802.3af for camera
- Auxiliary power 12-48V DC, 24V AC
- Power consumption: 5.43 Watts maximum

### Compliance

- Class A FCC, Part 15; EN55022 Class A, EN55024, EN61000-3-2, EN61000-3-3 RoHS, REACH
- CE Mark, UL Listed

### Programmability

- Wide dynamic range switch control
- Binned Mode (AV3116)
- Flexible cropping
- On-camera real-time motion detection and privacy mask with 1024 detection zones
- Backlight compensation
- Auto multi-matrix white balance
- 50/60Hz selectable flicker control
- Electronic pan, tilt, zoom (PTZ)
- Electronic image flip: 180° rotation
- Resolution windowing down to 1x1 pixel for JPEG and 2x2 pixels for H.264
- Programmable shutter speed to help control motion blur
- MoonLight™ Mode: extended exposure and noise cancellation
- Programmable resolution, brightness, saturation, gamma, sharpness, tint
- Simultaneous delivery of full field-of-view and zoomed images
- Bandwidth and storage savings by running at 1/4 resolution
- Bit rate and bandwidth limitation control

### Industry Standard

- PSIA and ONVIF Conformant

### Environmental

- Operating temperature -5°C (23°F) to +50°C (122°F)
- Stable image temperature 0°C (32°F) to +50°C (122°F)
- Storage temperature -20°C (-4°F) to +60°C (140°F)
- Humidity 0% to 90% (non-condensing)

### Mechanical

- 3" W (76mm) x 2.5" H (63.5mm) x 1.25" D (31.7mm) (w/o lens)
- 5.8oz (164 grams) w/o lens
- C/CS lens mount

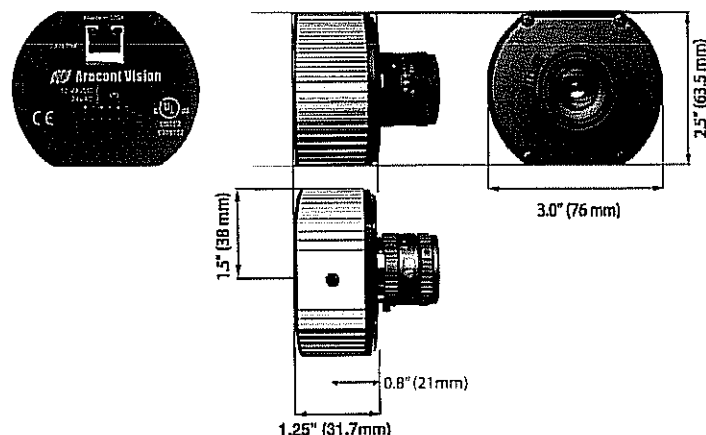

### Accessories

- HSG2: Outdoor IP67 housing with heater and dual fans
- D4SO: Outdoor 4" IP66, IK-10, dome housing

### Recommended Lenses

Manufacturer	Lenses	Focal Length (mm)	Format F-Stop	IR Coated	Horizontal FOV			
					AV3116DN		AV2116DN	
					Wide	Tele	Wide	Tele
Arecont Vision	MPL33-11	3.3-10.5	1/2.5", F1.4	No	78°	24°	73°	22°
Computer	T320312CS-MPIR	3-8	1/3", F1.2	Yes	85°	33°	79.6°	30.9°

\*Other MPL lenses not recommended for use with WDR cameras.

# AV3255/AV5255

3 Megapixel or 5 Megapixel H.264 Day/Night IP MegaDome<sup>®</sup> 2 Camera

## AV3255 Series

3MP Day/Night Remote Focus, Remote Zoom, Auto-Iris

AV3255AM	MD2 Base Model
AV3255AM-H	MD2 w/ Heater
AV3255AMIR	MD2 w/ IR LEDs
AV3255AMIR-H	MD2 w/ IR LEDs and Heater

## AV5255 Series

5MP Day/Night Remote Focus, Remote Zoom, Auto-Iris

AV5255AM	MD2 Base Model
AV5255AM-A	MD2 w/ Audio
AV5255AM-H	MD2 w/ Heater
AV5255AM-AH	MD2 w/Audio and Heater
AV5255AMIR	MD2 w/ IR LEDs
AV5255AMIR-A	MD2 w/ IR LEDs and Audio
AV5255AMIR-H	MD2 w/ IR LEDs and Heater
AV5255AMIR-AH	MD2 w/ IR LEDs, Audio and Heater



Remote Focus, Remote Zoom and  
Auto-Iris

The Fastest Frame Rates at 5MP and  
3MP Resolutions on the Market up to  
14fps @ 5MP and 21fps @ 3MP

Binned Mode to Increase Sensitivity  
and Low Light Performance

### Arecont Vision Advantages:

- All-in-One H.264 MegaDome Solution
- Remote Focus, Remote Zoom and Auto Iris Lens
- IP66 and Vandal Resistant Dome, IK10 Rated
- Total PoE Solution  
(No External Power Required for Heater and IR LEDs)
- True Day/Night Functionality with Removable IR Cut Filter
- PSIA and ONVIF Compliance
- New User Friendly Web-Page
- Easily Adjustable 3-axis Gimbal
- Dual Encoder H.264/MJPEG
- Privacy Mask, Motion Detection and Flexible Cropping
- Optional Audio, IR LEDs and Heater



Specification sheets subject to change without notice

Made in USA



# AV3255/AV5255

## Specifications

### Model Numbers:

<b>AV3255AM</b>	3MP MD2 Base Model
<b>AV3255AM-H</b>	3MP MD2 w/ Heater
<b>AV3255AMIR</b>	3MP MD2 w/ IR LEDs
<b>AV3255AMIR-H</b>	3MP MD2 w/ IR LEDs, Heater
<b>AV5255AM</b>	5MP MD2 Base Model
<b>AV5255AM-A</b>	5MP MD2 w/ Audio
<b>AV5255AM-H</b>	5MP MD2 w/ Heater
<b>AV5255AM-AH</b>	5MP MD2 w/ Audio, Heater
<b>AV5255AMIR</b>	5MP MD2 w/ IR LEDs
<b>AV5255AMIR-A</b>	5MP MD2 w/ IR LEDs, Audio
<b>AV5255AMIR-H</b>	5MP MD2 w/ IR LEDs, Heater
<b>AV5255AMIR-AH</b>	5MP MD2 w/ IR LEDs, Audio, Heater

### Imaging

- 3 megapixel effective CMOS image sensor (AV3255)
- 5 megapixel CMOS image sensor (AV5255)
- Progressive scan
- 1/2.5" optical format, 2.2  $\mu$ m pixel pitch
- Minimum illumination of:
  - Color (non-binned): 0.3 Lux @ F1.8
  - Color (binned): 0.15 Lux @ F1.8
  - Day/Night: 0 Lux, IR sensitive
- Dynamic range 70.1 dB
- Maximum SNR 44.1 dB

### Full Field of View (FOV) Resolution

Model Numbers	Full FOV Resolution	1/4 Resolution
AV3255	2048 (H) x 1536 (V)	1024 (H) x 768 (V)
AV5255	2592 (H) x 1944 (V)	1296 (H) x 972 (V)

### Lens

- 3.6-9mm, F1.8, remote focus, zoom and auto-iris lens
- HFOV = 71° - 25° (AV3255) / 96° - 36° (AV5255)

### Cropped (FOV) Resolution

- Flexible cropping - crop to 2 pixels in H.264 & 1 pixel in JPEG
- 2560x1600 QWXGA (AV5255)
- 2048x1536 3MP (AV5255)
- 1920x1080 HDTV-1080p
- 1280x1024 1.3MP
- 1280x720 HDTV - 720p
- 640x480 VGA

### Data Transmission

- Video frame rate up to:
  - AV5255:
    - 14fps @ 2592x1944
    - 16.5fps @ 2560x1600
  - AV3255/5255:
    - 21fps @ 2048x1536
    - 29fps @ 1920x1080
    - 41fps @ 1280x1024
- In binned mode up to:
  - AV5255:
    - 34fps @ 1296x972
    - 41fps @ 1280x800
  - AV3255/5255:
    - 47fps @ 1024x768
    - 64fps @ 960x540
    - 64fps @ 640x512
- Compression type
  - H.264 (MPEG-4, Part 10) / Motion JPEG
  - 21 levels of quality
- TFTP, HTTP, RTSP, RTP/TCP, RTP/UDP image transmission protocols
- 100Base-T Ethernet Network Interface
- Multi-streaming: 8 non-identical streams

### Environmental

- Operating temperature:
  - w/o Heater: -20°C (-4°F) to +50°C (122°F)
  - w/ Heater: -40°C (-40°F) to +50°C (122°F)
- Stable image temperature: 0°C (32°F) to +50°C (122°F)
- Storage temperature: -40°C (-40°F) to 60°C (140°F)
- Humidity 0% to 90% (non condensing)

### Compliance Information

- Compliance:
  - Class A FCC, Part 15; EN55022 Class A, EN55024, EN61000-3-2, EN61000-3-3, EN60950-1 RoHS, REACH, IK-10 (EN62262), IP66 (EN60529)
- CE Mark, UL Listed

### Programmability

- Remote focus, remote zoom and auto-iris
- Binned mode, flexible cropping and low light noise filter control
- Shutter speed: 1ms - 500ms
- Backlight compensation
- Auto multi-matrix white balance
- On-camera motion detection and privacy mask w/ 1024 detection zones
- 50/60Hz selectable flicker control
- Electronic pan, tilt, zoom (PTZ) and image flip - 180 degree rotation
- MoonLight™ mode - extended exposure & proprietary noise cancellation
- Programmable resolution, brightness, saturation, gamma, sharpness, tint
- Bit rate and bandwidth limitation control

### Camera Electrical

- General purpose opto-isolated input and output
- Power over Ethernet (PoE): PoE 802.3af for camera
- Auxiliary power 12-48V DC, 24V AC
- Power consumption:
  - 10.7 watts Base model / -AH model
  - 12.6 watts IR model / -IR-AH model

### Audio Electrical (-A models only)

- Streaming: Two-way
- Compression : G.711 PCM 8 kHz
- Input/output: External microphone input or line input / line output

### Heater Electrical (-H models only)

- Power Consumption: 2.28 W Max
- Switch: On: 4°C (32.9 °F), Off: 6.5 °C (43.7 °F)
- Total PoE Solution: No external power requirement

### IR Illuminator (-IR models only)

- 24 pcs 850nm LEDs / 15 meter IR distance (max) / 40° IR angle
- No external power required

### Industry standard

- PSIA compliance and ONVIF compliance

### Mechanical

- Casing
  - Die-casting aluminum chassis with 4" polycarbonate dome bubble
  - IP66 weather proof standard
  - Vandal resistant, IK10 rated
- Easily adjustable 3-axis camera gimbal w/ 360° pan, 90° tilt & 360° z-axis
- Total unit dimensions:
  - $\varnothing$ 5.5 x 4.9 in (H), bubble only:  $\varnothing$ 4.0 x 2.4 in (H)
  - $\varnothing$ 140.3 x 124.6 mm (H), bubble only:  $\varnothing$ 102 x 61.8 mm (H)
- 2.25 lbs (1.02kg)

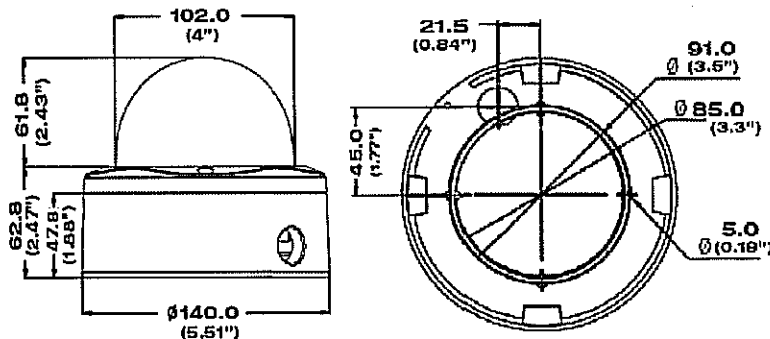

### Accessories:

- MD-WMT2: Wall mount w/ 1.5" NPT
- MD-CAP: Wall mount cap only w/ 1.5" NPT
- MD-CMT: Pendant mount
- MD-CRMA: Corner mount adapter
- MD-PMA: Pole mount adapter
- MD2-HK: Optional 2W heater kit
- SV-EBA: Electrical box adapter
- SV-JBA: Junction box adapter (for on-site installation)



Specification sheets subject to change without notice Revised 8.06.12 ©2011 Arecont Vision

# CCTV System Quote

## Better Solution



# MidCo Inc. Proposal

MidCo Inc.  
16W221 Shore Court  
Burr Ridge, IL 60527  
www.midcosystems.com

<b>Purchaser:</b>	City of Darien Public Works	<b>Quote Date:</b>	March 27, 2013
<b>Address:</b>	1041 S. Frontage Road Darien, IL (630) 353-8104	<b>Prepared By:</b>	Kelly Sullivan
<b>Phone:</b>		<b>E-Mail:</b>	ksullivan@midcosystems.com
<b>Fax:</b>		<b>Proposal #:</b>	132703KS-1
<b>Prepared For:</b>	Scott Coren	<b>E-Mail:</b>	scoren@darienil.gov

**Project:** CCTV System-Better **Total:** \$34,156.00  
Tax Not Included

Qty	Mfg.	Part No.	Description
<b>CCTV System (Better)</b>			
1	Exacq	1608-48-4000-DT	4 TB Hybrid Unit
2	Cisco	SRW208MP-1K9-NA	8 Port POE Managed Switch
2	Pelco	MCS8-5	Camera Power Supplies
<u>Cameras #1,3,4,5</u>			
4	Arecont	3255AM-IR-H	3 Megapixel Day/Night Camera
4	Arecont	MD-WMT2	Wall Mounts
4	Arecont	MD-CRMA	Corner Mounts
<u>Camera #2-License Plate</u>			
1	Arecont	AV3116DNv1	WDR 3 Megapixel Day/Night Camera
1	Arecont	HSG2	Outdoor Housing
1	Arecont	HSG2-WMT	Wall Mount for Housing
1	Arecont		Fujinon Zoom Lens
1	Arecont	VIS-1040-S850-1	IR Unit
1	Arecont	VIS-60-PWRS	Power Supply for IR Unit
1	MidCo	Programming	Technical Support and Programming
1	MidCo	Drawings	Drafting and AutoCAD
1	MidCo	PM&ENG	Project Management and Engineering
1	MidCo	Training	Training
1	MidCo	Miscellaneous	Miscellaneous Connectors and Installation Material
1	Cable	1 Lot	Device Cabling

Price includes applicable installation labor unless otherwise noted. Price is exclusive of all conduit and electrical boxes. Our proposal includes adequate labor to connect, program and test circuits with your system. Troubleshooting network problems caused by 3rd party suppliers is not included with this proposal. Additional labor hours that are required as a result of the non-performance of these 3rd party devices will be invoiced at our prevailing rate.

Purchaser acknowledges receipt of MidCo's Terms and Conditions and Project Qualifications documents, understands them, and agrees to be bound by its provisions. Further, the purchaser agrees that it is the complete and exclusive statement of the agreement between the parties which superseded all proposals or prior agreements oral or written. Your sales price has a 4% cash payment discount included. If you would prefer to pay by credit card 4% will be added to your quoted purchase price.

MidCo Inc. Signature _____	Signature of Purchaser _____
Date _____	Date _____



# MidCo Inc. Proposal

MidCo Inc.  
16W221 Shore Court  
Burr Ridge, IL 60527  
www.midcosystems.com

<b>Purchaser:</b>	City of Darien Public Works	<b>Proposal Date:</b>	March 27, 2013
<b>Address:</b>	1041 S. Frontage Road	<b>Prepared By:</b>	Kelly Sullivan
<b>City, St, Zip</b>	Darien, IL	<b>E-Mail:</b>	ksullivan@midcosystems.com
<b>Phone</b>	(630) 353-8104	<b>Proposal #:</b>	132703KS-1
<b>Fax:</b>			
<b>Prepared For:</b>	Scott Coren	<b>E-Mail:</b>	scoren@darienil.gov

Project: CCTV System-Better

Page 2

Qty	Mfg.	Part No.	Description
-----	------	----------	-------------

**NOTES**

Assumes that each building will have a network  
Customer to provide network connection within 5  
feet of Headend  
IP addresses by customer  
Power for cameras provided by others  
Lift provided by others  
Conduit not included  
Monitors not included-can be added upon request  
Assumes all work to be completed during normal  
business hours, Monday-Friday

**OPTIONS**

\* Options include all necessary equipment & labor  
\* Options not included in total

5	Ditek	Recommended MR.IPOE	<u>LIGHTENING PROTECTION</u> Lightening Protection	\$1,299.00
2	Engenius	ENH202	<u>Wirelss Network at Each Building</u> Outdoor Bridge	\$1,512.00

NOTE: Network will be needed

Price includes applicable installation labor unless otherwise noted. Price is exclusive of all conduit and electrical boxes. Our proposal includes adequate labor to connect, program and test circuits with your system. Troubleshooting network problems caused by 3rd party suppliers is not included with this proposal. Additional labor hours that are required as a result of the non-performance of these 3rd party devices will be invoiced at our prevailing rate.

Purchaser acknowledges receipt of MidCo's Terms and Conditions and Project Qualifications documents, understands them, and agrees to be bound by its provisions. Further, the purchaser agrees that it is the complete and exclusive statement of the agreement between the parties which superseded all proposals or prior agreements oral or written. Your sales price has a 4% cash payment discount included. If you would prefer to pay by credit card 4% will be added to your quoted purchase price.

MidCo Inc. Signature _____	Signature of Purchaser _____
Date _____	Date _____

*This proposal valid for 15 days from Date of Proposal*      *Page 2 of 2*      *Phone # (630) 887-1800 - Fax# (630) 887-1962*



**Project Qualifications**

**City of Darien Public Works - CCTV System-Better**

Included by MidCo	Not Incl. by MidCo	Item Description
	x	Supply A.C. Power from Breakers to Security Panel
	x	Supply A.C. Power, up to 25' to Security Panel
	x	Electrical Earth Ground
	x	Conduit with Pull string
	x	Conduit Stubs
	x	Painting of Exposed Electrical Conduit
	x	WireMold for Exposed Cabling
x		Standard Back boxes
	x	Special Back boxes
	x	Lightning / Surge protection
	x	Door Locking Hardware/Mechanisms
	x	Door Hardware Power (up to 0.33 amps per lock)
	x	UPS Emergency Power Source
	x	Man Lifts
	x	Job Trailer or Job Storage Gang box
	x	MidCo Inc. Standard Insurance
	x	Telco / Data Closet Plywood Backboards
	x	Patching / Painting
	x	Ceiling Tile Removal/Replacement
	x	Performance and Payment Bond
	x	Required Permits and any additional Fee's
	x	Liquidated Damages
	x	Consequential Damages
	x	Any asbestos inspection or removal costs of any kind
	x	Based the pre-billing for items like Turnstiles, Gates, etc. to meet manufacture or supplier terms and conditions
	x	Minimum costs for add's, moves and changes on construction jobs of 10% overhead and 10% profit.
x		Subject to Site Testing and Conditions

Included by MidCo	Not Incl. by MidCo	Item Description
x		Plenum Cable
	x	PVC Cable
x		Wire Labels (For MidCo Supplied Cable)
	x	Abandoned Cable Removal
x		System Server - Computer Hardware
	x	Client Workstation(s) - Computer Hardware
	x	Network Interface Units
x		Hubs / Routers/ Switches
	x	Fire alarm Relays as needed from building FAS vendor
	x	Cable from Fire Panel to Fire Relay
	x	Elevator cabling
	x	Security Console Cabinetry
x		Project Management
x		Training - up to XX Hours
	x	Premium Time Work
x		Escorted System Testing ( 1 test)
x		System Drawings (Block Diagram)
	x	Panel (Typical Wiring) Drawings
	x	Device (Typical Wiring) Drawings
	x	Floor plans with Device Locations.
	x	Out of Town Travel,Hotel,Per Diem,Car Rental
	x	Freight
	x	Estimated Taxes

By Cust. YES	By Cust. NO	CUSTOMER SUPPLIED ITEMS
		Please fill out if applicable
x		Static IP addresses if needed
x		Alarm dedicated phone line
x		Customers Network Equipment

**CAD DRAWINGS:** In order for MidCo to supply system drawings or floor plan device layouts, AutoCAD backgrounds must be furnished to MidCo in file format (\*.dxf / \*.dwg) at no charge to MidCo by owner or owner's representative.

**A.C. POWER/GROUNDING and UPS System:** Dedicated, Computer Grade A.C. Power must be available for operation of Security Equipment. Dedicated A.C. circuit(s) must be provided appropriate for the amount of current draw for equipment being installed. Voltage levels and noise immunity must be equal to or better than industry standards and equipment manufacturer requirements. Also, an earth ground connection must be provided for proper grounding at equipment locations. Supplying earth ground from electrical supply is not included, and if needed will be installed on a Time and Material invoice basis. A UPS system is always required on all security panels and head-end computer equipment to maintain the MidCo Inc. warranty negotiated on each project.

**EXISTING DEVICES:** If applicable, existing field devices which are re-used are assumed to be in satisfactory operating condition. Troubleshooting and/or repair of existing devices will be performed by MidCo on a Time and Material invoice basis.

**EXISTING CABLE:** If applicable, existing wire and/or cabling which is re-used is assumed to be in satisfactory operating condition, and of equal or better technical specification than required by the manufacturer of installed equipment. Troubleshooting or replacement of sub-standard wire/cabling will be performed by MidCo on a Time and Material invoice basis.

**VIRUS PROTECTION:** Virus Protection for computer systems is a requirement of the customer, allowing consistency with other customer computer equipment. Routine virus definition updates are the responsibility of the customer. Service calls due to virus created problems are not covered under warranty protection, and will be subject to Time and Material invoicing.

**DATA BACKUP:** MidCo will backup system data at installation completion, and train customer on system data backups. Data re-entry due to lack of backup is not included in warranty coverage, and will be subject to Time and Material invoicing. It is recommended that the customer do periodic system and database backup's on a daily basis if possible.

**OPERATING SYSTEM:** If supplied by MidCo, computer operating system software will be current up to guidelines supplied by the application software manufacturer. Upgrades are the responsibility of the customer, but must be coordinated with MidCo and the application software manufacturer in order to insure application compatibility with operating system upgrades.

Notes:

Customer  
Signature/Date

MidCo Signature/Date



## TERMS AND CONDITIONS

### EXCLUSIVE WARRANTY AND REMEDY

MidCo's exclusive warranty is that Services will be performed in a workmanlike fashion and all parts provided by MidCo shall be free of defects in material and workmanship for a period of one year, or as otherwise stated on the front of this Agreement, from the date of either substantial installation completion, or beneficial use of system, whichever is sooner. MidCo further agrees that all Services performed without furnishing parts shall be free of defects for a period of thirty (30) days, unless otherwise noted. MidCo's warranty period applies during normal business hours, Monday through Friday, 8 a.m. to 4:30 p.m. C.S.T.

**IN THE EVENT MIDCO BREACHES THIS WARRANTY, MIDCO'S SOLE OBLIGATION AND CUSTOMER'S EXCLUSIVE REMEDY, SHALL BE TO HAVE MIDCO MAKE ALL NECESSARY ADJUSTMENTS, REPAIRS, OR REPLACEMENT OF PARTS WHICH WERE DEFECTIVE AT THE TIME OF INSTALLATION.** There are no other express or implied warranties concerning any Service, parts, supplies, or expendable items provided hereunder. MidCo does not guarantee that the operation of the equipment will be uninterrupted or error-free. **MIDCO DISCLAIMS THE IMPLIED WARRANTIES OF MERCHANTABILITY AND FITNESS FOR A PARTICULAR PURPOSE, THE FOREGOING SHALL BE THE SOLE REMEDY OF CUSTOMER FOR BREACH OF WARRANTY.**

### INSTALLATION SERVICES

MidCo will perform the following Services at MidCo's standard charges when installation is specified in this Service Order. MidCo shall install the equipment as listed in accordance with local electrical codes and manufacturer's specifications or as otherwise shown. All work will be completed, unless otherwise agreed to, during Seller's normal business hours. Customer agrees to furnish a dedicated, properly grounded, commercial power circuit.

**THIS AGREEMENT SHALL BECOME NULL AND VOID IF EQUIPMENT IS SERVICED OR RELOCATED BY PARTIES OTHER THAN MIDCO INC. WITHOUT THE WRITTEN CONSENT OF MIDCO INC.**

### ADDITIONAL CHARGES

Services performed as a result of any of the following conditions shall be subject to additional charges for labor, transportation and parts; alterations of equipment not authorized in writing by MidCo; failure of third party circuits; failure of cable, cable plants, or cable infrastructure(s), unless specifically warranted or covered on the face of this Agreement; expendable supply items, damage or failure resulting from improper use, including use by the Customer of any equipment or software in a manner not intended by the manufacturer or MidCo Inc., any acts other acts, events, programming alterations, additions, or deletions, which may adversely effect system integrity or performance, occasioned by the Customer or third-parties; use of third-party equipment in combination with system equipment not otherwise supplied, covered or previously authorized for such use by MidCo Inc. in writing.

Damage resulting from events commonly referred to as "acts of God", including, but not limited to, weather and weather-related damage, lightning strikes, flood damage, water damage, hail, tornado, hurricane, earthquake, fire, acts of terrorism or similar acts, damage resulting from misuse and/or abuse, in-transit damage, accident, neglect, power surge or failure, operating environment, or the use of supplies or accessories which are not in conformance with the equipment manufacturer's published specifications; site surveys; **OR EVENTS OTHER THAN NORMAL WEAR AND TEAR.**

### LIMITATION OF LIABILITY

**IN NO EVENT SHALL MIDCO BE LIABLE IN CONTRACT, TORT OR OTHERWISE FOR INCIDENTAL, CONSEQUENTIAL, SPECIAL OR INDIRECT DAMAGES, INCLUDING WITHOUT LIMITATION, LOST BUSINESS PROFITS NOR DAMAGE OR DESTRUCTION OF DATA EVEN IF IT HAS BEEN ADVISED OF THE POSSIBILITY OF SAME,** except as to personal injury. MidCo's maximum liability shall be limited in any event to the actual direct damages incurred by Customer, which are caused, solely by the acts or omissions of MidCo subject to a maximum liability of the lesser of the amount paid for the services performed under this Service Order (subject to a maximum of one twelve (12) months duration) of \$1,000.00. Customer agrees to provide MidCo with prompt written notification as to the specifics of any claim for damages and to provide MidCo with a reasonable opportunity to investigate. **NO LIMITATION AS TO DAMAGES FOR PERSONAL INJURY IS INTENDED.**

### SECURITY INTEREST

To secure payment and performance of all Purchaser's obligations hereunder. Purchaser hereby grants to Seller a security interest in and to the goods covered by this contract and in and to any additions and accessions thereto provided, never less, that the risk of any loss or damage to the goods shall pass to Purchaser upon shipment to Purchaser or upon delivery to Purchaser's premises, whichever is earlier. Until Seller has been paid in full, Purchaser shall not in any mannered sell, transfer, lease, mortgage or encumber its interest in the goods covered by this contract nor part with possession thereof, without the Seller's prior written consent.

### FORCE MAJEURE

The parties' performance under this Agreement is subject to acts of God, war, government regulation, threats or acts of terrorism or similar acts, governmental travel advisories, disaster, strikes, civil disorder, curtailment of transportation facilities, or any other cause beyond the parties' control, making it inadvisable, illegal or impossible to perform their obligations under the Agreement. Either party may cancel the Agreement for any one or more of such reasons upon ninety (90) days prior written notice to the other.

## PRICES

Prices shall be the price set forth on the face of this Agreement. All sales, property, excise and other federal, state, and local taxes (other than those based upon MidCo's net income), shall be paid by Customer. All invoices are payable within thirty (30) days of the date of the invoice. Customer shall make such arrangements for payment as MidCo may require and MidCo may suspend performance under this Agreement until such arrangements are made.

**PAST DUE AMOUNTS SHALL BE SUBJECT TO AN INTEREST CHARGE OF 1.5% PER MONTH**, or the highest rate permitted by law, plus all costs of collection. MidCo reserves the right to adjust the service charge in conformity with MidCo's standard charges in the event Customer changes the equipment or attaches additional features or equipment to the covered equipment after the date hereof.

## BILLING

Goods covered by this contract will be billed when installed or as otherwise specified. Labor, material and installation will be billed at MidCo's then-current labor rate upon completion of installation or upon the last day of each month in which installation is performed, at Seller's option. Purchaser agrees to pay Seller as follows: 50% down payment with order, 40% upon delivery of equipment and the remaining balance of 10% due net ten (10) days upon completion of installation. Past due amounts will be subject to an interest charge of 1.5% per month, or the highest rate permitted by law, plus all costs of collection. Prices and terms subject to change without notice. No returns will be allowed without written consent of the Seller.

## ENTIRE AGREEMENT

This Service Order Agreement sets forth the entire agreement of the parties with respect to the subject matter hereof and supersedes any prior agreement or negotiation between the parties. There is no other understanding, agreement, presentation, expressed or implied, statutory or otherwise, in any way limiting, extending, defining or relating to the provisions hereof. **NO AGREEMENT ALTERING, MODIFYING, OR EXTENDING THE TERMS OF THIS SERVICE ORDER SHALL BE VALID UNLESS IN WRITING, DULY SIGNED BY BOTH PARTIES HERETO.** The parties expressly acknowledge that they have not relied on any prior or contemporaneous oral or written representations or statements by the other party in connection with the subject matter of this Service Order.

Any term or condition of an offer set forth on any Purchase Order or any other document created by Customer of MidCo, which is inconsistent with any term or condition of this Service Order, shall be of no force or effect whatsoever. **NEITHER CUSTOMER NOR MIDCO SHALL BE BOUND BY ANY ORAL AGREEMENT OR REPRESENTATION IRRESPECTIVE OF BY WHOM OR WHEN MADE.**

## SEVERABILITY

Any provision or provisions of this Agreement which are unenforceable, invalid or contrary to law, or the inclusion of which would affect the validity or enforceability of this Agreement shall be of no force or effect, and in such event each and all of the remaining provisions of this Agreement shall subsist and remain and be fully effective according to the tenor of this Agreement the same as though any such invalid, unenforceable or unlawful provision or provisions had never been included in this Agreement.

## APPLICABLE LAW

This Agreement and each transaction contemplated hereunder shall be deemed to be made under the laws of the State of Illinois and shall be construed in accordance with the laws of said State.

# Better Solution Product Cut Sheets

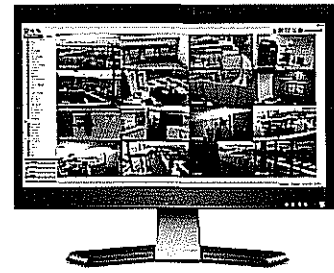
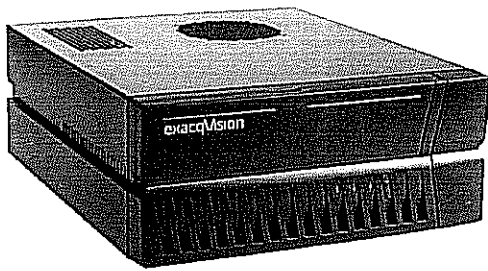

# exacqVision **A-Series**



**Hybrid Desktop**  
*Analog and IP Cameras*

## **exacqVision A-Series Desktop Hybrid Servers** *Compact, Reliable, Professional Grade Hybrid Systems*

### **Key Features & Benefits:**

- **True Hybrid** — Seamlessly integrate your existing analog and IP cameras from all of the leading camera vendors onto one server for centralized management. Includes up to 32 IP cameras per server and 64 analog inputs with 8 IP channels.
- **8 IP Camera Licenses Included** — Cost-effective solution providing complete control for multiple servers simultaneously. Add additional IP licenses as needed.
- **Pre-Configured with Intuitive exacqVision Software** — Powerful yet easy-to-use exacqVision VMS client interface operates on Windows, Linux and Macintosh
- **Cross-Compatible Operating System** — A-Series servers are available with Windows or Linux operating system. Easy to use client is available for Windows, Linux and Mac. Servers can also be accessed via any major web browser using the free exacqVision web service. All servers and clients are cross compatible.
- **Complete Solution** — The A-Series desktop hybrid server features an Intel i3 processor to handle server, client and web service applications all from the same unit.
- **3-Year Hardware Warranty, 3-Year Software Subscription Agreement** — Receive quarterly software updates for all the latest advancements as they are released along with access to technical support. IP Camera licenses never expire.
- **Included Mobile App** — Manage and monitor video remotely at any time by downloading the exacq mobile app for iPhone, iPad and Android devices
- **Space-Saving Chassis** — Compact, sturdy chassis easily fits on top of a desk.



Camera, Alarm & Audio Settings	Desktop
IP Cameras	4 or 8 IP licenses included. Expandable to 64 cameras per server (data rate dependent)
IP Compression Format	Camera dependent
Analog Inputs	8/16/32
Analog Outputs	1 mux, BNC
Analog Compression	H.264/MPEG-4/MJPEG
Analog Frame Rate (NTSC)	240/480/960
Analog Frame Rate (PAL)	200/400/800
Serial Connections	RS-485 (PTZ) & RS-232 port
Alarm Inputs	8 TTL
Alarm Outputs	3TTL + 1 relay output
Audio Inputs	8/16/32
Audio Outputs	1
Storage & Memory	
RAM	2 GB (standard), 4 GB (optional)
Drive Bays	2
Storage Maximum (Internal)	Up to 4 TB
Features	
NIC	2
USB2 Ports	8 x USB 2.0
Monitor Output	1 VGA + 1 HDMI 1.4 + 1 DVI-D, maximum 2 simultaneous monitors
Processor	Intel® i3 (standard), Intel® i5 (optional)
Keyboard & Mouse	Included
DVD/CD RW	Included
Watchdog Timer	Included
Server Operating System	Windows 7 Pro on 30 GB HDD Partition or Linux Ubuntu 10.04 (kernel 3.0) embedded on 4GB flash drive
VMS Software Included	exacqVision Professional (standard), exacqVision Enterprise Server (optional)
Compatible Client Operating System	Windows 7, Vista, XP, Server 2003/2008 32-bit or 64-bit Linux (Ubuntu) Mac OS X 
Regulatory	CE (Class A), FCC (Class A), UL Listed
Warranty	3 years, parts & labor plus 3 years SSA included 
Size	
Dimensions (l x w x h)	15.675 x 13 x 5.375 in 39.7 x 33.1 x 14.6 cm
Weight	18.5 – 22 lbs. 8.4 – 10 kg
Requirements	
Operating Temperature	40° – 95°F (4.5° – 35°C)
Relative Humidity	5 – 95% RH (non-condensing)
Input Voltage	120/240 VAC auto-sensing
Power Consumption	<250 Watts (150 watts typical)
Power Cables	North America (standard), UK & EU (optional)

Part Numbers	
Model #	Hard Drive
<b>8 Analog Inputs – 240 FPS Models</b>	
0804-24-0500-DT	500 GB
0804-24-1000-DT	1 TB
0804-24-2000-DT	2 TB
0804-24-4000-DT	4 TB
<b>16 Analog Inputs – 480 FPS Models</b>	
1608-48-0500-DT	500 GB
1608-48-1000-DT	1 TB
1608-48-2000-DT	2 TB
1608-48-4000-DT	4 TB
<b>32 Analog Inputs – 960 FPS Models</b>	
3208-96-0500-DT	500 GB
3208-96-1000-DT	1 TB
3208-96-2000-DT	2 TB
3208-96-4000-DT	4 TB

Specifications subject to change. Visit [www.exacq.com](http://www.exacq.com) for the most current product specifications.



**Exacq Technologies USA**  
11955 Exit Five Parkway  
Fishers, IN 46037 USA

**Exacq Technologies Europe**  
Business & Technology Centre  
Bessemer Drive  
Stevenage, Herts SG1 2DX UK

+1.317.845.5710 USA  
+5255.56080817 Mexico  
+44.1438.310163 UK  
+44.1438.310163 Europe  
+852.8120.9275 Hong Kong

**exacq**<sup>®</sup>  
Technologies  
[www.exacq.com](http://www.exacq.com)

# AV3255/AV5255

3 Megapixel or 5 Megapixel H.264 Day/Night IP MegaDome<sup>®</sup> 2 Camera

## AV3255 Series

3MP Day/Night Remote Focus, Remote Zoom, Auto-Iris

AV3255AM	MD2 Base Model
AV3255AM-H	MD2 w/ Heater
AV3255AMIR	MD2 w/ IR LEDs
AV3255AMIR-H	MD2 w/ IR LEDs and Heater

## AV5255 Series

5MP Day/Night Remote Focus, Remote Zoom, Auto-Iris

AV5255AM	MD2 Base Model
AV5255AM-A	MD2 w/ Audio
AV5255AM-H	MD2 w/ Heater
AV5255AM-AH	MD2 w/Audio and Heater
AV5255AMIR	MD2 w/ IR LEDs
AV5255AMIR-A	MD2 w/ IR LEDs and Audio
AV5255AMIR-H	MD2 w/ IR LEDs and Heater
AV5255AMIR-AH	MD2 w/ IR LEDs, Audio and Heater



Remote Focus, Remote Zoom and  
Auto-Iris

The Fastest Frame Rates at 5MP and  
3MP Resolutions on the Market up to  
14fps @ 5MP and 21fps @ 3MP

Binned Mode to Increase Sensitivity  
and Low Light Performance

### Arecont Vision Advantages:

- All-in-One H.264 MegaDome Solution
- Remote Focus, Remote Zoom and Auto Iris Lens
- IP66 and Vandal Resistant Dome, IK10 Rated
- Total PoE Solution  
(No External Power Required for Heater and IR LEDs)
- True Day/Night Functionality with Removable IR Cut Filter
- PSIA and ONVIF Compliance
- New User Friendly Web-Page
- Easily Adjustable 3-axis Gimbal
- Dual Encoder H.264/MJPEG
- Privacy Mask, Motion Detection and Flexible Cropping
- Optional Audio, IR LEDs and Heater



Specification sheets subject to change without notice

Made in USA



# AV3255/AV5255

## Specifications

### Model Numbers:

<b>AV3255AM</b>	3MP MD2 Base Model
<b>AV3255AM-H</b>	3MP MD2 w/ Heater
<b>AV3255AMIR</b>	3MP MD2 w/ IR LEDs
<b>AV3255AMIR-H</b>	3MP MD2 w/ IR LEDs, Heater
<b>AV5255AM</b>	5MP MD2 Base Model
<b>AV5255AM-A</b>	5MP MD2 w/ Audio
<b>AV5255AM-H</b>	5MP MD2 w/ Heater
<b>AV5255AM-AH</b>	5MP MD2 w/ Audio, Heater
<b>AV5255AMIR</b>	5MP MD2 w/ IR LEDs
<b>AV5255AMIR-A</b>	5MP MD2 w/ IR LEDs, Audio
<b>AV5255AMIR-H</b>	5MP MD2 w/ IR LEDs, Heater
<b>AV5255AMIR-AH</b>	5MP MD2 w/ IR LEDs, Audio, Heater

### Imaging

- 3 megapixel effective CMOS image sensor (AV3255)
- 5 megapixel CMOS image sensor (AV5255)
- Progressive scan
- 1/2.5" optical format, 2.2  $\mu$ m pixel pitch
- Minimum illumination of:
  - Color (non-binned): 0.3 Lux @ F1.8
  - Color (binned): 0.15 Lux @ F1.8
  - Day/Night: 0 Lux, IR sensitive
- Dynamic range 70.1 dB
- Maximum SNR 44.1 dB

### Full Field of View (FOV) Resolution

Model Numbers	Full FOV Resolution	1/4 Resolution
AV3255	2048 (H) x 1536 (V)	1024 (H) x 768 (V)
AV5255	2592 (H) x 1944 (V)	1296 (H) x 972 (V)

### Lenses

- 3.6-9mm, F1.8, remote focus, zoom and auto-iris lens
- HFOV = 71° - 25° (AV3255) / 96° - 36° (AV5255)

### Cropped (FOV) Resolution

- Flexible cropping - crop to 2 pixels in H.264 & 1 pixel in JPEG
- 2560x1600 QWXGA (AV5255)
- 2048x1536 3MP (AV5255)
- 1920x1080 HDTV-1080p
- 1280x1024 1.3MP
- 1280x720 HDTV - 720p
- 640x480 VGA

### Data Transmission

- Video frame rate up to:
  - AV5255:
    - 14fps @ 2592x1944
    - 16.5fps @ 2560x1600
  - AV3255/5255:
    - 21fps @ 2048x1536
    - 29fps @ 1920x1080
    - 41fps @ 1280x1024
- In binned mode up to:
  - AV5255:
    - 34fps @ 1296x972
    - 41fps @ 1280x800
  - AV3255/5255:
    - 47fps @ 1024x768
    - 64fps @ 960x540
    - 64fps @ 640x512
- Compression type
  - H.264 (MPEG-4, Part 10) / Motion JPEG
  - 21 levels of quality
- TFTP, HTTP, RTSP, RTP/TCP, RTP/UDP image transmission protocols
- 100Base-T Ethernet Network Interface
- Multi-streaming: 8 non-identical streams

### Environmental

- Operating temperature:
  - w/o Heater: -20°C (-4°F) to +50°C (122°F)
  - w/ Heater: -40°C (-40°F) to +50°C (122°F)
- Stable image temperature: 0°C (32°F) to +50°C (122°F)
- Storage temperature: -40°C (-40°F) to 60°C (140°F)
- Humidity 0% to 90% (non condensing)

### Compliance Information

- Compliance:
  - Class A FCC, Part 15; EN55022 Class A, EN55024, EN61000-3-2, EN61000-3-3, EN60950-1 RoHS, REACH, IK-10 (EN62262), IP66 (EN60529)
- CE Mark, UL Listed

### Programmability

- Remote focus, remote zoom and auto-iris
- Binned mode, flexible cropping and low light noise filter control
- Shutter speed: 1ms - 500ms
- Backlight compensation
- Auto multi-matrix white balance
- On-camera motion detection and privacy mask w/ 1024 detection zones
- 50/60Hz selectable flicker control
- Electronic pan, tilt, zoom (PTZ) and image flip - 180 degree rotation
- MoonLight™ mode - extended exposure & proprietary noise cancellation
- Programmable resolution, brightness, saturation, gamma, sharpness, tint
- Bit rate and bandwidth limitation control

### Camera Electrical

- General purpose opto-isolated input and output
- Power over Ethernet (PoE): PoE 802.3af for camera
- Auxiliary power 12-48V DC, 24V AC
- Power consumption:
  - 10.7 watts Base model / -AH model
  - 12.6 watts IR model / -IR-AH model

### Audio Electrical (-A models only)

- Streaming: Two-way
- Compression : G.711 PCM 8 kHz
- Input/output: External microphone input or line input / line output

### Heater Electrical (-H models only)

- Power Consumption: 2.28 W Max
- Switch: On: 4°C (32.9 °F), Off: 6.5 °C (43.7 °F)
- Total PoE Solution: No external power requirement

### IR Illuminator (-IR models only)

- 24 pcs 850nm LEDs / 15 meter IR distance (max) / 40° IR angle
- No external power required

### Industry standard

- PSIA compliance and ONVIF compliance

### Mechanical

- Casing
  - Die-casting aluminum chassis with 4" polycarbonate dome bubble
  - IP66 weather proof standard
  - Vandal resistant, IK10 rated
- Easily adjustable 3-axis camera gimbal w/ 360° pan, 90° tilt & 360° z-axis
- Total unit dimensions:
  - $\varnothing$ 5.5 x 4.9 in (H), bubble only:  $\varnothing$ 4.0 x 2.4 in (H)
  - $\varnothing$ 140.3 x 124.6 mm (H), bubble only:  $\varnothing$ 102 x 61.8 mm (H)
- 2.25 lbs (1.02kg)

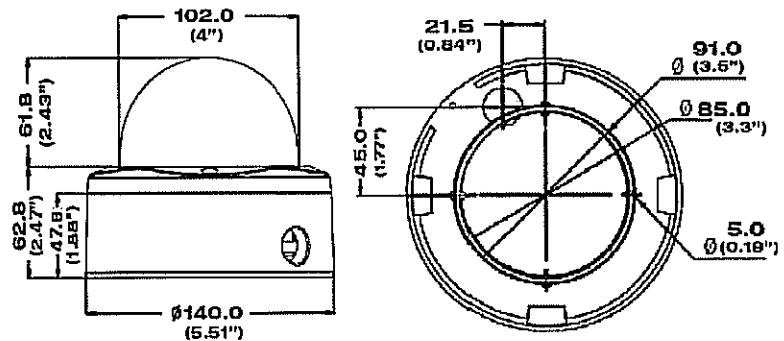

### Accessories:

- MD-WMT2: Wall mount w/ 1.5" NPT
- MD-CAP: Wall mount cap only w/ 1.5" NPT
- MD-CMT: Pendant mount
- MD-CRMA: Corner mount adapter
- MD-PMA: Pole mount adapter
- MD2-HK: Optional 2W heater kit
- SV-EBA: Electrical box adapter
- SV-JBA: Junction box adapter (for on-site installation)



Specification sheets subject to change without notice Revised 8.06.12 ©2011 Arecont Vision

# AV2116DN/AV3116DN

**Arecont Vision**  
megapixel technology...  
beyond imagination

Full HD 1080p and 3-Megapixel Compact H.264 WDR IP MegaVideo Camera

**AV2116DNv1** Full HD 1080p WDR Day/Night

**AV3116DNv1** 3MP WDR Day/Night



## The True Wide Dynamic Range Camera

WDR up to 100dB Allowing Users to See Clearly in Shaded and Bright Light Conditions Simultaneously

Binned Mode Improves Low-Light Performance in 3MP Versions

## Arecont Vision Advantages:

- True Wide Dynamic Range Control
- True Day/Night Functionality with Removeable IR Cut Filter
- Dual Encoder H.264/MJPEG
- The Fastest Frame Rates on the Market
- Privacy Mask, Motion Detection and Flexible Cropping
- PSIA and ONVIF Conformant
- New User Friendly Web-Page
- Bit Rate Control to Control Bandwidth
- PoE and Auxiliary Power: 12-48V DC/24V AC
- Forensic Zooming
- Compact Package



Specification sheets subject to change without notice.

Made in the USA





# AV2116DN/AV3116DN

## Specifications

### Model Numbers

- AV2116DNv1** Full HD 1080p Wide Dynamic Range, Day/Night  
**AV3116DNv1** 3MP Wide Dynamic Range, Day/Night

### Imaging

- 2.07-megapixel effective CMOS image sensor (AV2116)
- 3-megapixel CMOS image sensor (AV3116)
- 1/3.2" optical format
- 2.2 µm pixel pitch
- Progressive Scan
- Minimum illumination of:
  - Color (non-binned): 0.3 Lux @ F1.4
  - Color (binned): 0.15 Lux @ F1.4
  - Day/Night: 0 Lux, IR sensitive
- Wide Dynamic range up to 100 dB
- Maximum SNR 49 dB

### Full Field-of-View (FOV) Resolution

Mode Numbers	Full FOV Resolution	1/4 Resolution
AV2116	1080p 1920 (H) x 1080 (V)	960 (H) x 540 (V)
AV3116	3MP 2048 (H) x 1536 (V)	1024 (H) x 768 (V)

### Cropped (FOV) Resolution

- Flexible Cropping - Crop to 2 pixels in H.264 and 1 pixel in JPEG
- 1920x1200 WUXG (AV3116)
  - 1920x1080 HDTV - 1080p (AV3116)
  - 1600x1200 2MP (AV3116)
  - 1280x1024 1.3MP
  - 1280x720 HDTV - 720p
  - 640x480 VGA

### Data Transmission

- Video frame rate up to:
  - 21fps @ 2048x1536 (AV3116)
  - 31fps @ 1600x1200 (AV3116)
  - 30fps @ 1920x1080
  - 41fps @ 1280x1024
- Video frame in binned mode up to:
  - 21fps @ 1024x768 (AV3116)
  - 27fps @ 800x600 (AV3116)
  - 31fps @ 860x540 (AV3116)
  - 32fps @ 640x512 (AV3116)
- Compression type
  - H.264 (MPEG-4, Part 10)/Motion JPEG
  - 21 levels of quality
- TFTP, HTTP, RTSP, RTP/TCP, RTP/UDP image transmission protocols
- 100Base-T Ethernet Network Interface
- Multi-streaming: 8 non-identical streams

### Electrical

- General purpose opto-coupled input and output
- Power over Ethernet (PoE): PoE 802.3af for camera
- Auxiliary power 12-48V DC, 24V AC
- Power consumption: 5.43 Watts maximum

### Compliance

- Class A FCC, Part 15; EN55022 Class A, EN55024, EN61000-3-2, EN61000-3-3 RoHS, REACH
- CE Mark, UL Listed

### Programmability

- Wide dynamic range switch control
- Binned Mode (AV3116)
- Flexible cropping
- On-camera real-time motion detection and privacy mask with 1024 detection zones
- Backlight compensation
- Auto multi-matrix white balance
- 50/60Hz selectable flicker control
- Electronic pan, tilt, zoom (PTZ)
- Electronic image flip: 180° rotation
- Resolution windowing down to 1x1 pixel for JPEG and 2x2 pixels for H.264
- Programmable shutter speed to help control motion blur
- MoonLight™ Mode: extended exposure and noise cancellation
- Programmable resolution, brightness, saturation, gamma, sharpness, tint
- Simultaneous delivery of full field-of-view and zoomed images
- Bandwidth and storage savings by running at 1/4 resolution
- Bit rate and bandwidth limitation control

### Industry Standard

- PSIA and ONVIF Conformant

### Environmental

- Operating temperature -5°C (23°F) to +50°C (122°F)
- Stable image temperature 0°C (32°F) to +50°C (122°F)
- Storage temperature -20°C (-4°F) to +60°C (140°F)
- Humidity 0% to 90% (non-condensing)

### Mechanical

- 3" W (76mm) x 2.5" H (63.5mm) x 1.25" D (31.7mm) (w/o lens)
- 5.8oz (164 grams) w/o lens
- C/CS lens mount

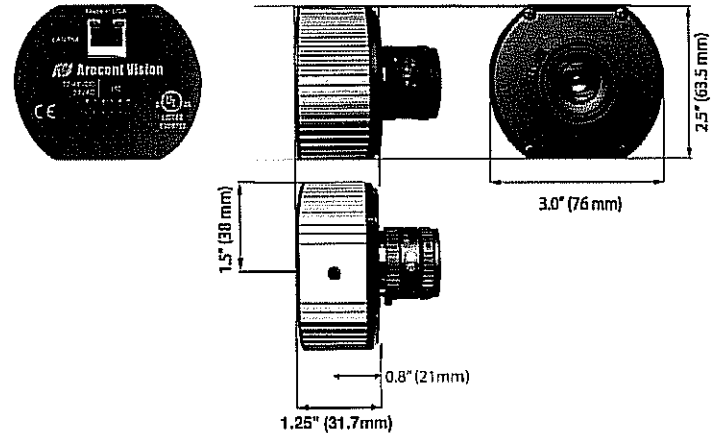

### Accessories

- HSG2: Outdoor IP67 housing with heater and dual fans
- D4SO: Outdoor 4" IP66, IK-10, dome housing

### Recommended Lenses

Manufacturer	Lenses	Focal Length (mm)	Format F-Stop	IR Coated	Horizontal FOV			
					AV3116DN		AV2116DN	
					Wide	Tele	Wide	Tele
Arecont Vision	MPL33-11	3.3-10.5	1/2.5", F1.4	No	78°	24°	73°	22°
Computer	T3Z0312CS-MPIR	3-8	1/3", F1.2	Yes	85°	33°	79.6°	30.9°

\*Other MPL lenses not recommended for use with WDR cameras.

# CCTV System Quote

## Best Solution



# MidCo Inc. Proposal

MidCo Inc.  
 16W221 Shore Court  
 Burr Ridge, IL 60527  
 www.midcosystems.com

<b>Purchaser:</b>	City of Darien Public Works	<b>Quote Date:</b>	March 27, 2013
<b>Address:</b>	1041 S. Frontage Road Darien, IL (630) 353-8104	<b>Prepared By:</b>	Kelly Sullivan
<b>Phone:</b>		<b>E-Mail:</b>	ksullivan@midcosystems.com
<b>Fax:</b>		<b>Proposal #:</b>	132703KS-1
<b>Prepared For:</b>	Scott Coren	<b>E-Mail:</b>	scoren@darienil.gov

**Project: CCTV System-Best**

**Total: \$45,671.00**  
 Tax Not Included

Qty	Mfg.	Part No.	Description
<b>CCTV System (Best)</b>			
1	Exacq	1608-48-4000-DT	4 TB Hybrid Unit
2	Cisco	SRW208MP-K9-NA	8 Port POE Managed Switch
2	Pelco	MCS8-5	Camera Power Supplies
<u>Cameras #1,3,4,5</u>			
4	Arecont	AV8185DN-HB	8 Megapixel 180 Camera
4	Arecont	SV-WMT	Wall Mounts
4	Arecont	VIS-1040-S850-1	IR Units
<u>Camera #2-License Plate</u>			
1	Arecont	AV3116DNv1	WDR 3 Megapixel Day/Night Camera
1	Arecont	HSG2	Outdoor Housing
1	Arecont	HSG2-WMT	Wall Mount for Housing
1	Arecont		Fujinon Zoom Lens
1	Arecont	VIS-1040-S850-1	IR Unit
4	Arecont	VIS-60-PWRS	Power Supply for IR Units
1	MidCo	Programming	Technical Support and Programming
1	MidCo	Drawings	Drafting and AutoCAD
1	MidCo	PM&ENG	Project Management and Engineering
1	MidCo	Training	Training
1	MidCo	Miscellaneous	Miscellaneous Connectors and Installation Material
1	Cable	1 Lot	Device Cabling

Price includes applicable installation labor unless otherwise noted. Price is exclusive of all conduit and electrical boxes. Our proposal includes adequate labor to connect, program and test circuits with your system. Troubleshooting network problems caused by 3rd party suppliers is not included with this proposal. Additional labor hours that are required as a result of the non-performance of these 3rd party devices will be invoiced at our prevailing rate.

Purchaser acknowledges receipt of MidCo's Terms and Conditions and Project Qualifications documents, understands them, and agrees to be bound by its provisions. Further, the purchaser agrees that it is the complete and exclusive statement of the agreement between the parties which superseded all proposals or prior agreements oral or written. Your sales price has a 4% cash payment discount included. If you would prefer to pay by credit card 4% will be added to your quoted purchase price.

MidCo Inc. Signature _____	Signature of Purchaser _____
Date _____	Date _____



# MidCo Inc. Proposal

MidCo Inc.  
16W221 Shore Court  
Burr Ridge, IL 60527  
www.midcosystems.com

<b>Purchaser:</b>	City of Darien Public Works	<b>Proposal Date:</b>	March 27, 2013
<b>Address:</b>	1041 S. Frontage Road	<b>Prepared By:</b>	Kelly Sullivan
<b>City, St, Zip</b>	Darien, IL	<b>E-Mail:</b>	ksullivan@midcosystems.com
<b>Phone</b>	(630) 353-8104	<b>Proposal #:</b>	132703KS-1
<b>Fax:</b>		<b>E-Mail:</b>	scoren@darienil.gov
<b>Prepared For:</b>	Scott Coren		

Project: CCTV System-Best  
Page 2

Qty	Mfg.	Part No.	Description	
-----	------	----------	-------------	--

**NOTES**

Assumes that each building will have a network  
Customer to provide network connection within 5  
feet of Headend  
IP addresses by customer  
Power for cameras provided by others  
Lift provided by others  
Conduit not included  
Monitors not included-can be added upon request  
Assumes all work to be completed during normal  
business hours, Monday-Friday

**OPTIONS**

\* Options include all necessary equipment & labor  
\* Options not included in total

5	Ditek	Recommended MRJPOE	<u>LIGHTENING PROTECTION</u> Lightening Protection	\$1,299.00
---	-------	-----------------------	---	------------

2	Engenius	ENH202	<u>Wireless Network at Each Building</u> Outdoor Bridge	\$1,512.00
---	----------	--------	--	------------

NOTE: Network will be needed

Price includes applicable installation labor unless otherwise noted. Price is exclusive of all conduit and electrical boxes. Our proposal includes adequate labor to connect, program and test circuits with your system. Troubleshooting network problems caused by 3rd party suppliers is not included with this proposal. Additional labor hours that are required as a result of the non-performance of these 3rd party devices will be invoiced at our prevailing rate.

Purchaser acknowledges receipt of MidCo's Terms and Conditions and Project Qualifications documents, understands them, and agrees to be bound by its provisions. Further, the purchaser agrees that it is the complete and exclusive statement of the agreement between the parties which superseded all proposals or prior agreements oral or written. Your sales price has a 4% cash payment discount included. If you would prefer to pay by credit card 4% will be added to your quoted purchase price.

MidCo Inc. Signature _____	Signature of Purchaser _____
Date _____	Date _____

*This proposal valid for 15 days from Date of Proposal* Page 2 of 2 Phone # (630) 887-1800 - Fax# (630) 887-1962



**Project Qualifications**  
**City of Darien Public Works - CCTV System-Best**

Included by MidCo	Not Incl. by MidCo	Item Description
	x	Supply A.C. Power from Breakers to Security Panel
	x	Supply A.C. Power, up to 25' to Security Panel
	x	Electrical Earth Ground
	x	Conduit with Pull string
	x	Conduit Stubs
	x	Painting of Exposed Electrical Conduit
	x	WireMold for Exposed Cabling
x		Standard Back boxes
	x	Special Back boxes
	x	Lighting / Surge protection
	x	Door Locking Hardware/Mechanisms
	x	Door Hardware Power (up to 0.33 amps per lock)
	x	UPS Emergency Power Source
	x	Man Lifts
	x	Job Trailer or Job Storage Gang box
	x	MidCo Inc. Standard Insurance
	x	Telco / Data Closet Plywood Backboards
	x	Patching / Painting
	x	Ceiling Tile Removal/Replacement
	x	Performance and Payment Bond
	x	Required Permits and any additional Fee's
	x	Liquidated Damages
	x	Consequential Damages
	x	Any asbestos inspection or removal costs of any kind
	x	Based the pre-billing for items like Turnstiles, Gates, etc. to meet manufacture or supplier terms and conditions
	x	Minimum costs for add's, moves and changes on construction jobs of 10% overhead and 10% profit.
x		Subject to Site Testing and Conditions

Included by MidCo	Not Incl. by MidCo	Item Description
x		Plenum Cable
	x	PVC Cable
x		Wire Labels (For MidCo Supplied Cable)
	x	Abandoned Cable Removal
x		System Server - Computer Hardware
	x	Client Workstation(s) - Computer Hardware
	x	Network Interface Units
x		Hubs / Routers/ Switches
	x	Fire alarm Relays as needed from building FAS vendor
	x	Cable from Fire Panel to Fire Relay
	x	Elevator cabling
	x	Security Console Cabinetry
x		Project Management
x		Training - up to 4 Hours
	x	Premium Time Work
x		Escorted System Testing ( 1 test)
x		System Drawings (Block Diagram)
	x	Panel (Typical Wiring) Drawings
	x	Device (Typical Wiring) Drawings
	x	Floor plans with Device Locations.
	x	Out of Town Travel,Hotel,Per Diem,Car Rental
	x	Freight
	x	Estimated Taxes

By Cust. YES	By Cust. NO	CUSTOMER SUPPLIED ITEMS
		Please fill out if applicable
x		Static IP addresses if needed
x		Alarm dedicated phone line
x		Customers Network Equipment

**CAD DRAWINGS:** In order for MidCo to supply system drawings or floor plan device layouts, AutoCAD backgrounds must be furnished to MidCo in file format (\*.dxf / \*.dwg) at no charge to MidCo by owner or owner's representative.

**A.C POWER/GROUNDING and UPS System:** Dedicated, Computer Grade A.C. Power must be available for operation of Security Equipment. Dedicated A.C. circuit(s) must be provided appropriate for the amount of current draw for equipment being installed. Voltage levels and noise immunity must be equal to or better than industry standards and equipment manufacturer requirements. Also, an earth ground connection must be provided for proper grounding at equipment locations. Supplying earth ground from electrical supply is not included, and if needed will be installed on a Time and Material invoice basis. A UPS system is always required on all security panels and head-end computer equipment to maintain the MidCo Inc. warranty negotiated on each project.

**EXISTING DEVICES:** If applicable, existing field devices which are re-used are assumed to be in satisfactory operating condition. Troubleshooting and/or repair of existing devices will be performed by MidCo on a Time and Material invoice basis.

**EXISTING CABLE:** If applicable, existing wire and/or cabling which is re-used is assumed to be in satisfactory operating condition, and of equal or better technical specification than required by the manufacturer of installed equipment. Troubleshooting or replacement of sub-standard wire/cabling will be performed by MidCo on a Time and Material invoice basis.

**VIRUS PROTECTION:** Virus Protection for computer systems is a requirement of the customer, allowing consistency with other customer computer equipment. Routine virus definition updates are the responsibility of the customer. Service calls due to virus created problems are not covered under warranty protection, and will be subject to Time and Material invoicing.

**DATA BACKUP:** MidCo will backup system data at installation completion, and train customer on system data backups. Data re-entry due to lack of backup is not included in warranty coverage, and will be subject to Time and Material invoicing. It is recommended that the customer do periodic system and database backup's on a daily basis if possible.

**OPERATING SYSTEM:** If supplied by MidCo, computer operating system software will be current up to guidelines supplied by the application software manufacturer. Upgrades are the responsibility of the customer, but must be coordinated with MidCo and the application software manufacturer in order to insure application compatibility with operating system upgrades.

Notes:

Customer  
Signature/Date

MidCo Signature/Date

## TERMS AND CONDITIONS

### EXCLUSIVE WARRANTY AND REMEDY

MidCo's exclusive warranty is that Services will be performed in a workmanlike fashion and all parts provided by MidCo shall be free of defects in material and workmanship for a period of one year, or as otherwise stated on the front of this Agreement, from the date of either substantial installation completion, or beneficial use of system, whichever is sooner. MidCo further agrees that all Services performed without furnishing parts shall be free of defects for a period of thirty (30) days, unless otherwise noted. MidCo's warranty period applies during normal business hours, Monday through Friday, 8 a.m. to 4:30 p.m. C.S.T.

**IN THE EVENT MIDCO BREACHES THIS WARRANTY, MIDCO'S SOLE OBLIGATION AND CUSTOMER'S EXCLUSIVE REMEDY, SHALL BE TO HAVE MIDCO MAKE ALL NECESSARY ADJUSTMENTS, REPAIRS, OR REPLACEMENT OF PARTS WHICH WERE DEFECTIVE AT THE TIME OF INSTALLATION.** There are no other express or implied warranties concerning any Service, parts, supplies, or expendable items provided hereunder. MidCo does not guarantee that the operation of the equipment will be uninterrupted or error-free. **MIDCO DISCLAIMS THE IMPLIED WARRANTIES OF MERCHANTABILITY AND FITNESS FOR A PARTICULAR PURPOSE, THE FOREGOING SHALL BE THE SOLE REMEDY OF CUSTOMER FOR BREACH OF WARRANTY.**

### INSTALLATION SERVICES

MidCo will perform the following Services at MidCo's standard charges when installation is specified in this Service Order. MidCo shall install the equipment as listed in accordance with local electrical codes and manufacturer's specifications or as otherwise shown. All work will be completed, unless otherwise agreed to, during Seller's normal business hours. Customer agrees to furnish a dedicated, properly grounded, commercial power circuit.

**THIS AGREEMENT SHALL BECOME NULL AND VOID IF EQUIPMENT IS SERVICED OR RELOCATED BY PARTIES OTHER THAN MIDCO INC. WITHOUT THE WRITTEN CONSENT OF MIDCO INC.**

### ADDITIONAL CHARGES

Services performed as a result of any of the following conditions shall be subject to additional charges for labor, transportation and parts; alterations of equipment not authorized in writing by MidCo; failure of third party circuits; failure of cable, cable plants, or cable infrastructure(s), unless specifically warranted or covered on the face of this Agreement; expendable supply items, damage or failure resulting from improper use, including use by the Customer of any equipment or software in a manner not intended by the manufacturer or MidCo Inc., any acts other acts, events, programming alterations, additions, or deletions, which may adversely effect system integrity or performance, occasioned by the Customer or third-parties; use of third-party equipment in combination with system equipment not otherwise supplied, covered or previously authorized for such use by MidCo Inc. in writing.

Damage resulting from events commonly referred to as "acts of God", including, but not limited to, weather and weather-related damage, lightning strikes, flood damage, water damage, hail, tornado, hurricane, earthquake, fire, acts of terrorism or similar acts, damage resulting from misuse and/or abuse, in-transit damage, accident, neglect, power surge or failure, operating environment, or the use of supplies or accessories which are not in conformance with the equipment manufacturer's published specifications; site surveys; **OR EVENTS OTHER THAN NORMAL WEAR AND TEAR.**

### LIMITATION OF LIABILITY

**IN NO EVENT SHALL MIDCO BE LIABLE IN CONTRACT, TORT OR OTHERWISE FOR INCIDENTAL, CONSEQUENTIAL, SPECIAL OR INDIRECT DAMAGES, INCLUDING WITHOUT LIMITATION, LOST BUSINESS PROFITS NOR DAMAGE OR DESTRUCTION OF DATA EVEN IF IT HAS BEEN ADVISED OF THE POSSIBILITY OF SAME,** except as to personal injury. MidCo's maximum liability shall be limited in any event to the actual direct damages incurred by Customer, which are caused, solely by the acts or omissions of MidCo subject to a maximum liability of the lesser of the amount paid for the services performed under this Service Order (subject to a maximum of one twelve (12) months duration) of \$1,000.00. Customer agrees to provide MidCo with prompt written notification as to the specifics of any claim for damages and to provide MidCo with a reasonable opportunity to investigate. **NO LIMITATION AS TO DAMAGES FOR PERSONAL INJURY IS INTENDED.**

### SECURITY INTEREST

To secure payment and performance of all Purchaser's obligations hereunder. Purchaser hereby grants to Seller a security interest in and to the goods covered by this contract and in and to any additions and accessions thereto provided, never less, that the risk of any loss or damage to the goods shall pass to Purchaser upon shipment to Purchaser or upon delivery to Purchaser's premises, whichever is earlier. Until Seller has been paid in full, Purchaser shall not in any mannered sell, transfer, lease, mortgage or encumber its interest in the goods covered by this contract nor part with possession thereof, without the Seller's prior written consent.

### FORCE MAJEURE

The parties' performance under this Agreement is subject to acts of God, war, government regulation, threats or acts of terrorism or similar acts, governmental travel advisories, disaster, strikes, civil disorder, curtailment of transportation facilities, or any other cause beyond the parties' control, making it inadvisable, illegal or impossible to perform their obligations under the Agreement. Either party may cancel the Agreement for any one or more of such reasons upon ninety (90) days prior written notice to the other.

## PRICES

Prices shall be the price set forth on the face of this Agreement. All sales, property, excise and other federal, state, and local taxes (other than those based upon MidCo's net income), shall be paid by Customer. All invoices are payable within thirty (30) days of the date of the invoice. Customer shall make such arrangements for payment as MidCo may require and MidCo may suspend performance under this Agreement until such arrangements are made.

**PAST DUE AMOUNTS SHALL BE SUBJECT TO AN INTEREST CHARGE OF 1.5% PER MONTH**, or the highest rate permitted by law, plus all costs of collection. MidCo reserves the right to adjust the service charge in conformity with MidCo's standard charges in the event Customer changes the equipment or attaches additional features or equipment to the covered equipment after the date hereof.

## BILLING

Goods covered by this contract will be billed when installed or as otherwise specified. Labor, material and installation will be billed at MidCo's then-current labor rate upon completion of installation or upon the last day of each month in which installation is performed, at Seller's option. Purchaser agrees to pay Seller as follows: 50% down payment with order, 40% upon delivery of equipment and the remaining balance of 10% due net ten (10) days upon completion of installation. Past due amounts will be subject to an interest charge of 1.5% per month, or the highest rate permitted by law, plus all costs of collection. Prices and terms subject to change without notice. No returns will be allowed without written consent of the Seller.

## ENTIRE AGREEMENT

This Service Order Agreement sets forth the entire agreement of the parties with respect to the subject matter hereof and supersedes any prior agreement or negotiation between the parties. There is no other understanding, agreement, presentation, expressed or implied, statutory or otherwise, in any way limiting, extending, defining or relating to the provisions hereof. **NO AGREEMENT ALTERING, MODIFYING, OR EXTENDING THE TERMS OF THIS SERVICE ORDER SHALL BE VALID UNLESS IN WRITING, DULY SIGNED BY BOTH PARTIES HERETO.** The parties expressly acknowledge that they have not relied on any prior or contemporaneous oral or written representations or statements by the other party in connection with the subject matter of this Service Order.

Any term or condition of an offer set forth on any Purchase Order or any other document created by Customer of MidCo, which is inconsistent with any term or condition of this Service Order, shall be of no force or effect whatsoever. **NEITHER CUSTOMER NOR MIDCO SHALL BE BOUND BY ANY ORAL AGREEMENT OR REPRESENTATION IRRESPECTIVE OF BY WHOM OR WHEN MADE.**

## SEVERABILITY

Any provision or provisions of this Agreement which are unenforceable, invalid or contrary to law, or the inclusion of which would affect the validity or enforceability of this Agreement shall be of no force or effect, and in such event each and all of the remaining provisions of this Agreement shall subsist and remain and be fully effective according to the tenor of this Agreement the same as though any such invalid, unenforceable or unlawful provision or provisions had never been included in this Agreement.

## APPLICABLE LAW

This Agreement and each transaction contemplated hereunder shall be deemed to be made under the laws of the State of Illinois and shall be construed in accordance with the laws of said State.

# Best Solution Product Cut Sheets



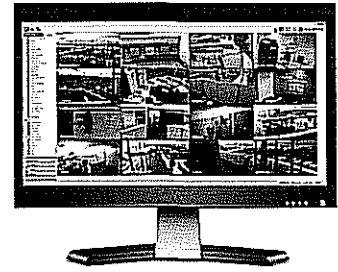
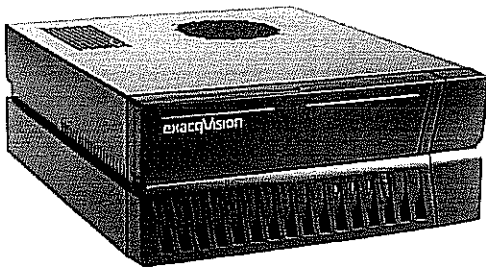

# exacqVision **A-Series**



**Hybrid Desktop**  
**Analog and IP Cameras**

## **exacqVision A-Series Desktop Hybrid Servers** *Compact, Reliable, Professional Grade Hybrid Systems*

### **Key Features & Benefits:**

- **True Hybrid** — Seamlessly integrate your existing analog and IP cameras from all of the leading camera vendors onto one server for centralized management. Includes up to 32 IP cameras per server and 64 analog inputs with 8 IP channels.
- **8 IP Camera Licenses Included** — Cost-effective solution providing complete control for multiple servers simultaneously. Add additional IP licenses as needed.
- **Pre-Configured with Intuitive exacqVision Software** — Powerful yet easy-to-use exacqVision VMS client interface operates on Windows, Linux and Macintosh
- **Cross-Compatible Operating System** — A-Series servers are available with Windows or Linux operating system. Easy to use client is available for Windows, Linux and Mac. Servers can also be accessed via any major web browser using the free exacqVision web service. All servers and clients are cross compatible.
- **Complete Solution** — The A-Series desktop hybrid server features an Intel i3 processor to handle server, client and web service applications all from the same unit.
- **3-Year Hardware Warranty, 3-Year Software Subscription Agreement** — Receive quarterly software updates for all the latest advancements as they are released along with access to technical support. IP Camera licenses never expire.
- **Included Mobile App** — Manage and monitor video remotely at any time by downloading the exacq mobile app for iPhone, iPad and Android devices
- **Space-Saving Chassis** — Compact, sturdy chassis easily fits on top of a desk.



Camera, Alarm & Audio Settings	Desktop
IP Cameras	4 or 8 IP licenses included. Expandable to 64 cameras per server (data rate dependent)
IP Compression Format	Camera dependent
Analog Inputs	8/16/32
Analog Outputs	1 mux, BNC
Analog Compression	H.264/MPEG-4/MJPEG
Analog Frame Rate (NTSC)	240/480/960
Analog Frame Rate (PAL)	200/400/800
Serial Connections	RS-485 (PTZ) & RS-232 port
Alarm Inputs	8 TTL
Alarm Outputs	3TTL + 1 relay output
Audio Inputs	8/16/32
Audio Outputs	1
Storage & Memory	
RAM	2 GB (standard), 4 GB (optional)
Drive Bays	2
Storage Maximum (Internal)	Up to 4 TB
Features	
NIC	2
USB2 Ports	8 x USB 2.0
Monitor Output	1 VGA + 1 HDMI 1.4 + 1 DVI-D, maximum 2 simultaneous monitors
Processor	Intel® i3 (standard), Intel® i5 (optional)
Keyboard & Mouse	Included
DVD/CD RW	Included
Watchdog Timer	Included
Server Operating System	Windows 7 Pro on 30 GB HDD Partition or Linux Ubuntu 10.04 (kernel 3.0) embedded on 4GB flash drive
VMS Software Included	exacqVision Professional (standard), exacqVision Enterprise Server (optional)
Compatible Client Operating System	Windows 7, Vista, XP, Server 2003/2008 32-bit or 64-bit Linux (Ubuntu) Mac OS X 
Regulatory	CE (Class A), FCC (Class A), UL Listed
Warranty	3 years, parts & labor plus 3 years SSA included 
Size	
Dimensions (l x w x h)	15.675 x 13 x 5.375 in 39.7 x 33.1 x 14.6 cm
Weight	18.5 – 22 lbs. 8.4 – 10 kg
Requirements	
Operating Temperature	40° – 95°F (4.5° – 35°C)
Relative Humidity	5 – 95% RH (non-condensing)
Input Voltage	120/240 VAC auto-sensing
Power Consumption	<250 Watts (150 watts typical)
Power Cables	North America (standard), UK & EU (optional)

Specifications subject to change. Visit [www.exacq.com](http://www.exacq.com) for the most current product specifications.

Part Numbers	
Model #	Hard Drive
8 Analog Inputs – 240 FPS Models	
0804-24-0500-DT	500 GB
0804-24-1000-DT	1 TB
0804-24-2000-DT	2 TB
0804-24-4000-DT	4 TB
16 Analog Inputs – 480 FPS Models	
1608-48-0500-DT	500 GB
1608-48-1000-DT	1 TB
1608-48-2000-DT	2 TB
1608-48-4000-DT	4 TB
32 Analog Inputs – 960 FPS Models	
3208-96-0500-DT	500 GB
3208-96-1000-DT	1 TB
3208-96-2000-DT	2 TB
3208-96-4000-DT	4 TB



**Exacq Technologies USA**  
11955 Exit Five Parkway  
Fishers, IN 46037 USA

**Exacq Technologies Europe**  
Business & Technology Centre  
Bessemer Drive  
Stevenage, Herts SG1 2DX UK

+1.317.845.5710 USA  
+5255.56080817 Mexico  
+44.1438.310163 UK  
+44.1438.310163 Europe  
+852.8120.9275 Hong Kong

**exacq**<sup>®</sup>  
Technologies  
[www.exacq.com](http://www.exacq.com)

# AV2116DN/AV3116DN

**Arecont Vision**  
megapixel technology...  
beyond imagination

Full HD 1080p and 3-Megapixel Compact H.264 WDR IP MegaVideo Camera

**AV2116DNv1** Full HD 1080p WDR Day/Night

**AV3116DNv1** 3MP WDR Day/Night



## The True Wide Dynamic Range Camera

WDR up to 100dB Allowing Users to  
See Clearly in Shaded and Bright Light  
Conditions Simultaneously

Binned Mode Improves Low-Light  
Performance in 3MP Versions

## Arecont Vision Advantages:

- True Wide Dynamic Range Control
- True Day/Night Functionality with Removeable IR Cut Filter
- Dual Encoder H.264/MJPEG
- The Fastest Frame Rates on the Market
- Privacy Mask, Motion Detection and Flexible Cropping
- PSIA and ONVIF Conformant
- New User Friendly Web-Page
- Bit Rate Control to Control Bandwidth
- PoE and Auxiliary Power: 12-48V DC/24V AC
- Forensic Zooming
- Compact Package

PSIA ONVIF

Specification sheets subject to change without notice.

Made in the USA



# AV2116DN/AV3116DN

## Specifications

### Model Numbers

- AV2116DNv1** Full HD 1080p Wide Dynamic Range, Day/Night  
**AV3116DNv1** 3MP Wide Dynamic Range, Day/Night

### Imaging

- 2.07-megapixel effective CMOS image sensor (AV2116)
- 3-megapixel CMOS image sensor (AV3116)
- 1/3.2" optical format
- 2.2 µm pixel pitch
- Progressive Scan
- Minimum illumination of:
  - Color (non-binned): 0.3 Lux @ F1.4
  - Color (binned): 0.15 Lux @ F1.4
  - Day/Night: 0 Lux, IR sensitive
- Wide Dynamic range up to 100 dB
- Maximum SNR 49 dB

### Full Field-of-View (FOV) Resolution

Mode Numbers	Full FOV Resolution	1/4 Resolution
AV2116	1080p 1920 (H) x 1080 (V)	960 (H) x 540 (V)
AV3116	3MP 2048 (H) x 1536 (V)	1024 (H) x 768 (V)

### Cropped (FOV) Resolution

- Flexible Cropping - Crop to 2 pixels in H.264 and 1 pixel in JPEG
- 1920x1200 WUXG (AV3116)
  - 1920x1080 HDTV - 1080p (AV3116)
  - 1600x1200 2MP (AV3116)
  - 1280x1024 1.3MP
  - 1280x720 HDTV - 720p
  - 640x480 VGA

### Data Transmission

- Video frame rate up to:
  - 21fps @ 2048x1536 (AV3116)
  - 31fps @ 1600x1200 (AV3116)
  - 30fps @ 1920x1080
  - 41fps @ 1280x1024
- Video frame in binned mode up to:
  - 21fps @ 1024x768 (AV3116)
  - 27fps @ 800x600 (AV3116)
  - 31fps @ 860x540 (AV3116)
  - 32fps @ 640x512 (AV3116)
- Compression type
  - H.264 (MPEG-4, Part 10)/Motion JPEG
  - 21 levels of quality
- TFTP, HTTP, RTSP, RTP/TCP, RTP/UDP image transmission protocols
- 100Base-T Ethernet Network Interface
- Multi-streaming: 8 non-identical streams

### Electrical

- General purpose opto-coupled input and output
- Power over Ethernet (PoE): PoE 802.3af for camera
- Auxiliary power 12-48V DC, 24V AC
- Power consumption: 5.43 Watts maximum

### Compliance

- Class A FCC, Part 15; EN55022 Class A, EN55024, EN61000-3-2, EN61000-3-3 RoHS, REACH
- CE Mark, UL Listed

### Programmability

- Wide dynamic range switch control
- Binned Mode (AV3116)
- Flexible cropping
- On-camera real-time motion detection and privacy mask with 1024 detection zones
- Backlight compensation
- Auto multi-matrix white balance
- 50/60Hz selectable flicker control
- Electronic pan, tilt, zoom (PTZ)
- Electronic image flip: 180° rotation
- Resolution windowing down to 1x1 pixel for JPEG and 2x2 pixels for H.264
- Programmable shutter speed to help control motion blur
- MoonLight™ Mode: extended exposure and noise cancellation
- Programmable resolution, brightness, saturation, gamma, sharpness, tint
- Simultaneous delivery of full field-of-view and zoomed images
- Bandwidth and storage savings by running at 1/4 resolution
- Bit rate and bandwidth limitation control

### Industry Standard

- PSIA and ONVIF Conformant

### Environmental

- Operating temperature -5°C (23°F) to +50°C (122°F)
- Stable image temperature 0°C (32°F) to +50°C (122°F)
- Storage temperature -20°C (-4°F) to +60°C (140°F)
- Humidity 0% to 90% (non-condensing)

### Mechanical

- 3" W (76mm) x 2.5" H (63.5mm) x 1.25" D (31.7mm) (w/o lens)
- 5.8oz (164 grams) w/o lens
- C/CS lens mount

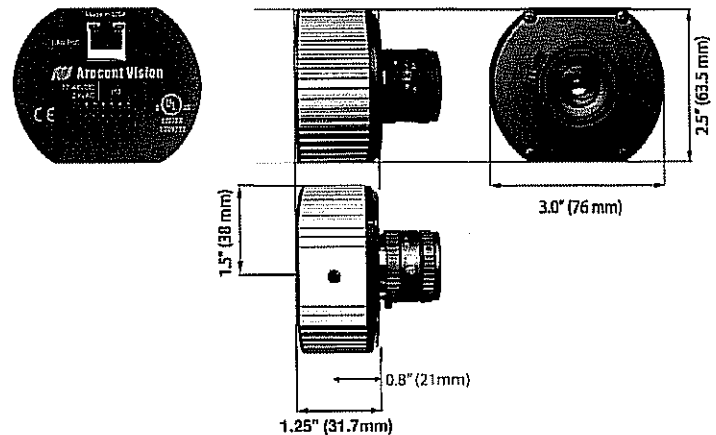

### Accessories

- HSG2: Outdoor IP67 housing with heater and dual fans
- D4SO: Outdoor 4" IP66, IK-10, dome housing

### Recommended Lenses

Manufacturer	Lenses	Focal Length (mm)	Format F-Stop	IR Coated	Horizontal FOV			
					AV3116DN		AV2116DN	
					Wide	Tele	Wide	Tele
Arecont Vision	MPL33-11	3.3-10.5	1/2.5", F1.4	No	78°	24°	73°	22°
Computer	T3Z0312CS-MPIR	3-8	1/3", F1.2	Yes	85°	33°	79.6°	30.9°

\*Other MPL lenses not recommended for use with WDR cameras.

# AV8185DN

**Arecont Vision**  
megapixel technology...  
beyond imagination

8 Megapixel H.264 Day/Night 180° Panoramic IP-camera

AV8185DN (Day/Night)

AV8185DN - HB (Day/Night with Heater & Blower)

## Arecont Vision Advantages:

### All-in-one H.264 Day/Night SurroundVideo Solution

- Integrated four 2 megapixel cameras, IR corrected lenses, Day/Night switchers and IP66 dome housing
- Vandal resistant aluminum chassis with 5.5" polycarbonate dome bubble
- Easily adjustable 2-axis camera gimbal with 360° pan and 90° tilt
- Supports both H.264 and MJPEG at full resolutions and full frame rates
- Heater and blower kit versions for cold climate environments
- Hard ceiling mount and Surface mount with optional pendant mount and wall mount
- IP66 weatherproofing standard

### ±0.5° Vertical Alignment to Locate Sensor Position

- Electrical alignment of four sensors

### H.264 (MPEG4, Part 10) Compression Standard

- Simultaneous support of both H.264 and MJPEG
- 10x average bandwidth and storage reduction over MJPEG

### World's First H.264 Day/Night Panoramic Megapixel Cameras

- 8 megapixel 180° field of view

### Bit Rate Control

- Maintain desired bandwidth and storage size

### Real Time Streaming Protocol (RTSP)

- Allows for compatibility with media players such as Apple QuickTime, Windows Media Player, VLC Player, etc.

### Superior Low Light Performance

- 1/2" CMOS sensor

### High Definition Panoramic 180° Imaging

- No de-warping software required
- Unparalleled High Definition Resolution - 1600 x 1200
- Resolution up to 1600(H) x 1200(V) per sensor
- Total resolution: 6400(H) x 1200(V) - (4 x 2 MP)
- Substitute up to twenty-four analog cameras

### Fastest Megapixel Image Rates

- Up to 22fps per channel

### Forensic Zooming

- Zoom live or after-event while recording full field of view in HD ... replace PTZ devices

### Reduced Overall System Cost

- Less cameras to install, less wiring, no external power (POE), less DVR licensing fees

### Other key features:

- Moonlight™ Mode - extended exposure and proprietary noise cancellation
- Up to four regions of interest for simultaneous panoramic and digital PTZ viewing and recording
- Image cropping to discard unnecessary scene and more



H.264 Day/Night SurroundVideo® Series

The AV8185DN Day/Night network camera is a part of Arecont Vision's full line of H.264 megapixel cameras. This fully compliant implementation of H.264 (MPEG 4, Part 10) is capable of sustaining over 80 billion operations per second and maintaining full motion progressive scan 1600 x 1200 video at 22 fps. Part of the SurroundVideo® line of cameras, it offers bandwidth and storage efficiency of 10X greater on average over MJPEG counterparts.

Learn more about our products at [www.arecontvision.com](http://www.arecontvision.com)

[www.arecontvision.com](http://www.arecontvision.com)    [avsales@arecontvision.com](mailto:avsales@arecontvision.com)    +1.818.937.0700    877.CAMERA.8

# AV8185DN

8 Megapixel H.264 Day/Night 180° Panoramic IP-camera

## Specifications

### Model Numbers:

**AV8185DN - Day/Night**

**AV8185DN-HB - Day/Night w/Heater & Blower**

AV8185DN: 180° Field of View

### Imaging

- Four 2 megapixel CMOS image sensors
- 1600(H) x 1200(V) pixel array each sensor
- 1/2" optical format
- Bayer mosaic RGB filter
- Minimum illumination of:
  - Color: 0.2 lux @ F2.0
  - Day/Night: 0 lux, IR sensitive
- Dynamic range 61 dB
- Maximum SNR 50 dB
- Moonlight™ mode - extended exposure and proprietary noise cancellation

### Full Field of View (FOV) Resolutions

- 1600(H)x1200(V) x 4      8 megapixel total
- 800(H)x600(V) x 4      2 MP total (1/4 resolution)

### Data Transmission

- Video frame rate up to:
  - 88 fps @ 800x600
  - 22 fps @ 1600x1200
  - 5.5 fps @ 6400x1200
- Compression type
  - H.264 (MPEG4, Part 10)
  - Motion JPEG
  - 21 levels of quality
- TFTP, HTTP, RTSP, RTP/TCP, RTP/UDP image transmission protocols
- 100Base-T Ethernet Network Interface
- Data rate
  - bit rate control from 100Kbps to 10Mbps
  - bit rate control available for full view, multi-view and archive
  - unthrottled data rate up to 55Mbps
- Multi-streaming: 8 non-identical streams

### Programmability

- +/- 5° Electrical Vertical Alignment to adjust vertical position of sensor image
- Auto exposure (AE) and Gain Control (AGC) >120dB
- On-camera motion detection with 64 detection zones
- Programmable backlight compensation
- Auto multi-matrix white balance
- 50/60Hz selectable flicker control
- Electronic pan, tilt, zoom (PTZ)
- Electronic image rotation - upside-down image turn
- Resolution windowing down to 32x32 pixels window
- Programmable motion blurring control for low-light mode
- Moonlight™ mode - extended exposure and proprietary noise cancellation
- Programmable resolution, brightness, saturation, gamma, sharpness, tint
- Up to four regions of interest for simultaneous panoramic and digital PTZ viewing and recording

### Electrical

- General purpose opto-coupled input and output
- Power over Ethernet (PoE): PoE 802.3af
- Auxiliary power: 12-48VDC and 24VAC
- Power consumption 9 Watts maximum

### Mechanical

- Easily adjustable 2-axis camera gimbal with 360° pan and 90° tilt
- Hard ceiling mount and surface mount embedded
- Die-cast aluminum chassis with 5.5" vandal resistant polycarbonate dome bubble
- Conduit fit 3/4" NPT standard
- Total Unit dimensions:
  - Ø6.8 x 6.9 in (H), bubble only: Ø5.5 x 3.4 in (H)
  - Ø175 x 176 mm (H), bubble only: Ø140 x 87 mm (H)
  - 2.0 lbs (0.91 kg)

### Regulatory Approvals

- FCC Class A
- CE and RoHS compliant

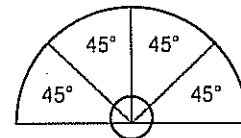

### Heater & Blower Electrical

- Voltage Input: 12V to 20V DC/24VAC (separate power required)
- Power Output: 11W Max (DC12V); 13W Max (AC24V)
- Heater Switch: On: 17°C (62.6 °F), Off: 30 °C (86 °F)
- Blower Switch: On: 10°C (50°F), Off: 15 °C (59 °F)
- Blower Switch: On: 50°C (122 °F), Off: 45 °C (113°F)

### Environmental

- IP66 weatherproofing standard
- Operating temperature:
  - No Heater: 0°C (32 °F) to +55°C (131 °F)
  - With Heater: -20°C (-4 °F) to +55°C (131 °F)
- Storage temperature - 40 °C (-40 °F) to 60 °C (140 °F)
- Humidity 0% to 90% (non condensing)

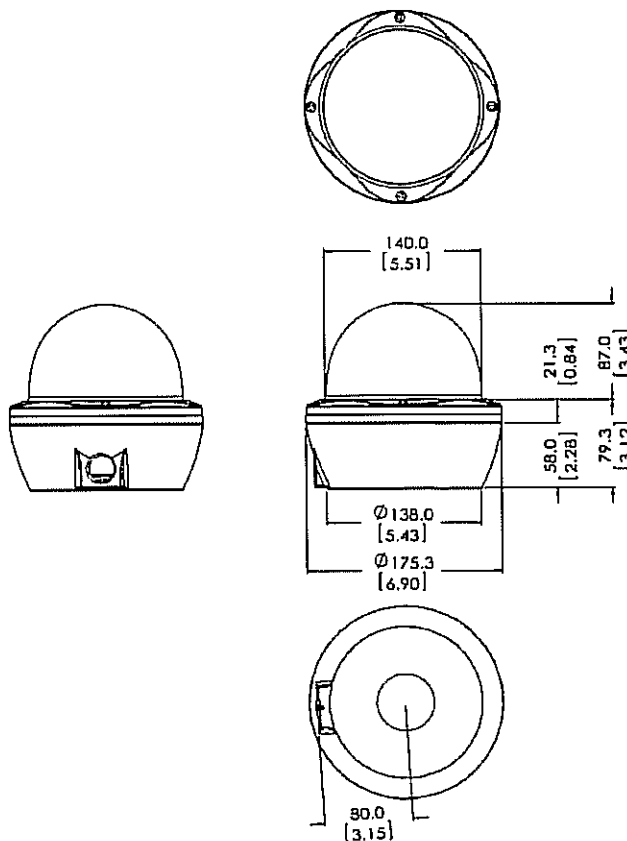

### Accessories:

- SV-WMT - Indoor/Outdoor Wall Mount
- SV-CMT - Indoor/Outdoor Ceiling Mount
- SV-FMA - Indoor/Outdoor Flush Mount Adapter
- MD-PMA - Indoor/Outdoor Pole Mount Adapter
- MD-CRMA - Indoor/Outdoor Corner Mount Adapter
- MV-EBA - Indoor/Outdoor Electrical Box Adapter

**Arecont Vision**  
megapixel technology...  
beyond imagination

Revised on 12.13.10

Made in USA

www.arecontvision.com

avsales@arecontvision.com

+1.818.937.0700

877.CAMERA.8

Arecont Vision reserves the right to change products or specifications without notice

©2008 Arecont Vision

High-Resolution • Panoramic Field of View • Greater FOV

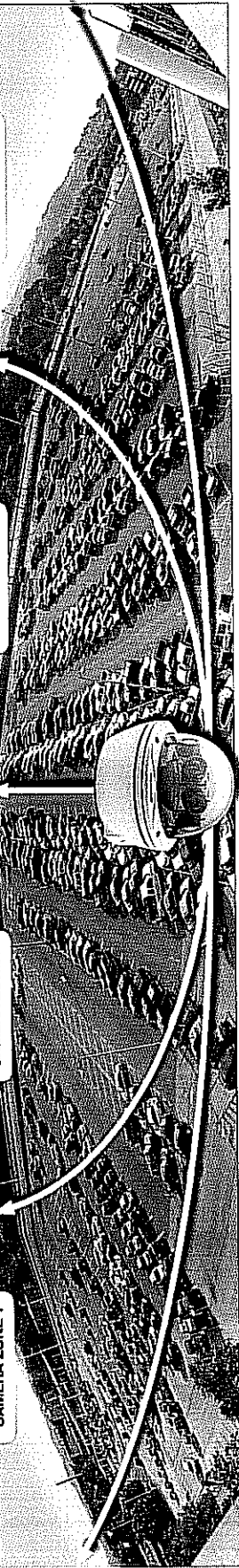

CAMERA ZONE 1

CAMERA ZONE 2

CAMERA ZONE 3

CAMERA ZONE 4

An area typically requiring multiple PTZ cameras or multiple fixed cameras can be covered with a single panoramic camera. It delivers comprehensive coverage with a dynamic field-of-view that is not possible in a fixed camera. A single camera can monitor multiple lanes of traffic, multiple lanes of a road and multiple lanes of a highway. For applications that require critical data like license plate recognition, combine the panoramic camera with single sensor integrated cameras at entrance and exit points.

Compliant H.264 Compression

- Compliant implementation of H.264 allows MJPEG, H.264 and H.264+ to be used with secondary energy storage.
- H.264 and MJPEG dual compression support with 4:1:1 video storage.
- Decrease the CPU load both at the client (decompression) and at the server (storage) side.
- Lower bandwidth and storage relative to MJPEG.
- Bi-rate coded to maintain desired bandwidth and storage life.
- Full frame Steady Picture (FPS) allows for compatibility with network servers such as Apple QuickTime, VCL and others.

Privacy Mask



Allows the ability to select multiple regions of an arbitrary shape and place the video. It is automatically built into all PTZ and PIP products, and features an on-board web browser.

H.264 Decompression (example)



CMP with live video in MJPEG - 20% with live video in H.264

Product Comparison

Model	Resolution	Field of View	Zoom	PTZ	IP	Power	Weight	Dimensions	Accessories
H.264	1080P	120°	10x	•	•	•	•	•	•
H.264	720P	120°	10x	•	•	•	•	•	•
H.264	480P	120°	10x	•	•	•	•	•	•
H.264	360P	120°	10x	•	•	•	•	•	•
H.264	288P	120°	10x	•	•	•	•	•	•
H.264	216P	120°	10x	•	•	•	•	•	•
H.264	144P	120°	10x	•	•	•	•	•	•
H.264	108P	120°	10x	•	•	•	•	•	•
H.264	720P	120°	10x	•	•	•	•	•	•
H.264	480P	120°	10x	•	•	•	•	•	•
H.264	360P	120°	10x	•	•	•	•	•	•
H.264	288P	120°	10x	•	•	•	•	•	•
H.264	216P	120°	10x	•	•	•	•	•	•
H.264	144P	120°	10x	•	•	•	•	•	•
H.264	108P	120°	10x	•	•	•	•	•	•

Configurations



Model H.264  
Resolution 1080P



Model H.264  
Resolution 720P



Model H.264  
Resolution 480P



Model H.264  
Resolution 360P



Model H.264  
Resolution 288P



Model H.264  
Resolution 216P



Model H.264  
Resolution 144P



Model H.264  
Resolution 108P

Allows higher resolution (up to 1080P) stream to be used in previous version.



Allows the ability to select multiple regions of an arbitrary shape and place the video. It is automatically built into all PTZ and PIP products, and features an on-board web browser.

Enhanced Low Light Performance

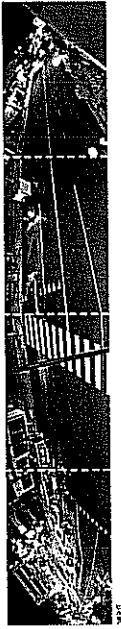

The latest addition to the SmartView family are the new Day/Night Low Light cameras which provide comprehensive field of view and excellent low light performance. The cameras' Day/Night sensors are designed to provide low light performance in high contrast environments. For optimal low light performance, the camera can be set to auto.

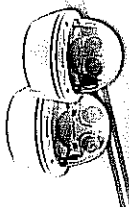

**Arecont Vision**  
megapixel technology...  
beyond imagination

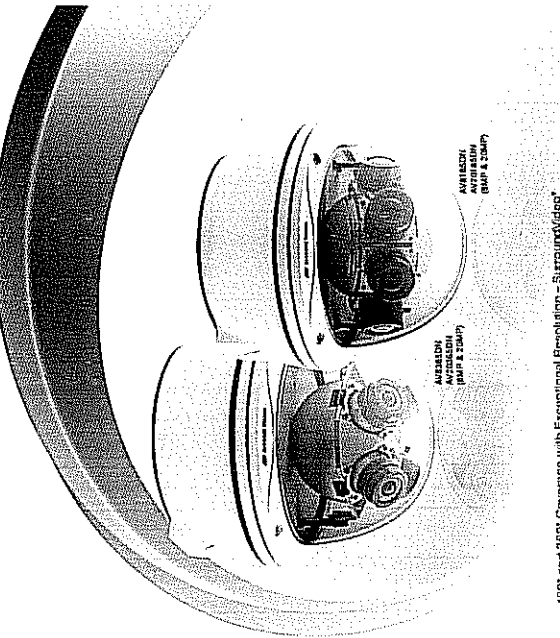

## SurroundVideo Megapixel IP Cameras

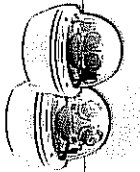

### 180° and 360° Coverage with Exceptional Resolution - SurroundVideo™

AVI8031 SurroundVideo™ Day/Night views recorded cameras from an alternate station for wide area surveillance. Available in 180° and 360° panoramic configurations. SurroundVideo™ cameras feature 8 and 20 megapixel cameras that deliver H.264 and H.264P cameras based in a central recording platform. A single SurroundVideo™ camera can monitor multiple cameras. At a glance, these cameras are easy to install, easy to use, and easy to maintain.

- 180° and 360° panoramic configurations
- 8 and 20 megapixel cameras
- H.264 and H.264P compression
- 100% uptime
- 24/7 operation
- 100% uptime
- 100% uptime
- 100% uptime
- 100% uptime
- 100% uptime
- 100% uptime
- 100% uptime

Corporate Headquarters  
 Arecont Vision  
 16650 Via Arroyo, Suite 100  
 Chino Hills, CA 91709  
 • 1 (818) 637-4744  
 www.arecontvision.com



- | Global Sales Team:   | Latin America:  | Asia Pacific:   | Middle East / Africa:   |
|--|---|---|---|
| <b>North America:</b><br>www.arecontvision.com<br>sales@arecontvision.com<br>1 (818) 637-4744<br>www.arecontvision.com | <b>Latin America:</b><br>latin@arecontvision.com<br>1 (818) 637-4744<br>www.arecontvision.com | <b>Asia Pacific:</b><br>asia@arecontvision.com<br>1 (818) 637-4744<br>www.arecontvision.com | <b>Middle East / Africa:</b><br>me@arecontvision.com<br>1 (818) 637-4744<br>www.arecontvision.com |

### Arecont Vision megapixel technology... beyond imagination™

www.arecontvision.com • 1 (818) 637-4744

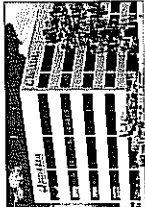

Arecont Vision is the leading provider of megapixel IP cameras and IP recording products. All products are made in the USA.



# LIGHTENING PROTECTION CUT SHEETS

(Listed as an option)



## DTK-PVP Series

### Fixed Camera Surge Protector General Product Specifications

DITEK's PVP27B protects all the sensitive feeds to fixed cameras, not just the video cable. Simple to install, the PVP27B series protects 24 Volt power conductors and video conductors in one compact package. With the lowest video let through voltage (and best surge protection) on the market, the PVP27B provides ideal surge protection for today's sensitive, high-quality fixed cameras. Models are available for Coax and Twisted Pair video connections.

DTK-PVP27BTPV

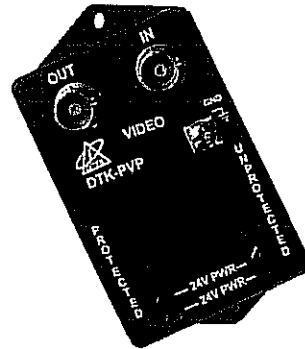
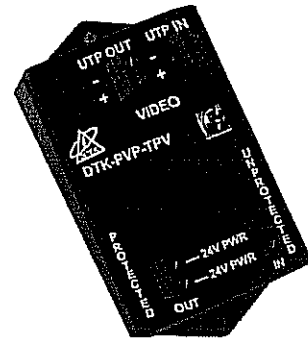

DTK-PVP27B

### DTK-PVP27B    DTK-PVP27BTPV

#### Product Features

- Protects power and video conductors in one package
- 5 Amp, 24V circuit protects power feeds to camera, heater, blower, defroster
- Multi-stage, SAD technology, hybrid design provides the best possible protection
- Single point ground improves protection and speeds installation
- Protect standard Coax or Twisted Pair video connections
- Ten Year Limited Warranty

#### Product Selector

- Coax connected camera:     **DTK-PVP27B**
- Twisted pair video camera: **DTK-PVP27BTPV**



# DTK-PVP Series

## Fixed Camera Surge Protector General Product Specifications



### Specifications:

	DTK-PVP27B	DTK-PVP27TPV
Connection Method (Video):	BNC	#22 - #14 AWG Screw Terminals
Connection Method (Power/Data):	#22 - #14 AWG Screw Terminals	
Video Band Pass:	0Hz - 10MHz	0Hz - 2GHz
Impedance:	75 Ω	n/a
Modes Protected (Video):	Center - Shield Shield - G	Positive - G Negative - G
Modes Protected (Power):	All Lines to Ground	
Service Voltage (Video):	2V peak - peak	
Service Voltage (Power):	24V AC/DC	
Clamping (Video):	2.8VDC	6.8VDC
Clamping (Power):	33VAC / 47VDC	
Surge Current (Video):	Center - Shield 10kA (8/20μs) Shield - Ground 150A (10/100μs)	114A/pair (10/100μs)
Surge Current (Power):	2,000 Amps	
Temperature Range:	-40°F to 158°F (-40°C to 70°C)	
Housing:	ABS	
Dimensions:	3.86" x 2.09" x 1.37" (98mm x 53mm x 35mm)	
Weight:	2.56 ounces (73 grams)	

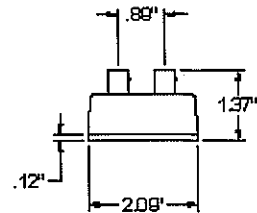
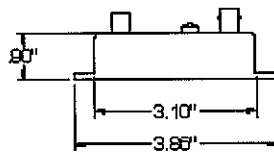
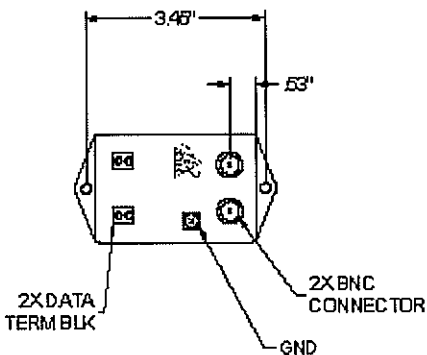



# DTK-MRJPOE

**Power Over Ethernet Power/Video/Data Surge Protection  
Gigabit Ethernet General Product Specifications**

DITEK's MRJPOE protects circuits that use state-of-the-art Power Over Ethernet connections. This point of use surge protector can be installed either at the equipment end or ahead of injectors or midspan devices. The DTK-MRJPOE is ideal surge protection for PoE DVRs, NVRs, cameras, telephones and access control systems.

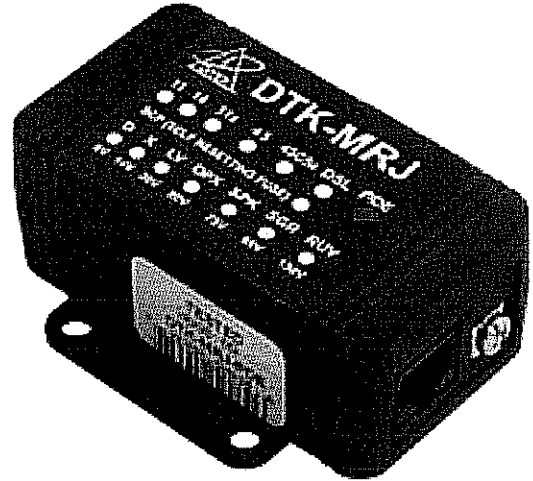

## DTK-MRJPOE

### Product Features

- Protects power, video and data on fixed or PTZ cameras
- RJ45 connection with external grounding screw
- Ethernet data speed without signal degradation
- Multi-stage, SAD technology, hybrid design provides the best possible protection
- Complies with IEEE Std. 802.3af and 802.3at for PoE
- Available as a single device or 12-Port, 1U Rack Mount (DTK-RM12POE)
- PoE Plus ready for high-wattage applications
- Ten Year Limited Warranty

### Performance Data

	DTK-MRJPOE
Service Voltage	48V
MCOV	64V
Clamp Voltage	72V
Peak Surge Current	30A/pair

### Specifications

**Agency Approvals:** UL497B

**Standards Compliance:**

CAT5e, EIA/TIA568A, EIA/TIA568B

**Connection Method:** RJ45 In/Out

**Pinout:** All 8 pins are protected

**Data Rate:** Gigabit Ethernet

**Max Continuous Current:** 1.5 Amps

**Dissipation:** 3,000W/pair (10/1000µs impulse)

**Protection Modes:** Line-Ground (All)

**Operating Temperature:** -40°F - 158°F (-40°C - 70°C)

**Maximum Humidity:** 95% non-condensing

**Dimensions:** 1.7" x 3.0" x 1.2"

(43mm x 76mm x 30mm)

**Weight:** 4oz (113g)

**Housing:** ABS



**ACKNOWLEDGEMENT & REFUSAL OF  
SURGE / LIGHTNING PROTECTION**

This is to certify that on this day the \_\_\_\_ of \_\_\_\_\_, 20 \_\_, I was advised to include surge protection devices with my installation of selected electronic and or electrical equipment. The protection that was proposed includes but may not be limited to the following:

**Fire:**

\_\_\_\_ Power, voice, signal and data line surge protection for Fire Alarm control panels including SLC, PIV, NAC, IDC signaling loops, Power, Communicators and IP DAC's.

**Surveillance:**

\_\_\_\_ Surge protection and battery backup for IP & Analog Surveillance systems to include head end equipment i.e. Switches, DVR or NVR's, fixed / pan tilt zoom cameras and network / backplane infrastructure.

**Power:**

\_\_\_\_ AC power surge protection for electrical main panels, distribution panels, sub panels, and electrical outlets.

**Access Control & Intrusion:**

\_\_\_\_ Surge protection for power, data, or network connections for access control systems, control panels, intrusion alarms, or other computerized equipment.

**Residential:**

\_\_\_\_ Surge protection for residential applications to include electrical panels, modem/phone/fax equipment, computer system connections, DSS/Cable TV devices, and home theater systems.

**Declination Statement:**

**I have declined the installation of surge protection devices as offered above. I understand that equipment damage resulting from a storm related event, lightning strike or from transient surges due to temporary over voltages, load & grid switching, capacitor bank discharges and other man-made causes may not be covered under original equipment manufacturers' product warranties.**

**I accept and assume full and complete responsibility for any transient surge damage that may occur to my installed equipment. I also agree to hold the installation company harmless and free of obligation in accordance with my decision.**

\_\_\_\_\_  
Customer Authorized Signature

\_\_\_\_\_  
Date

\_\_\_\_\_  
Servicing Representative Signature

\_\_\_\_\_  
Date

# BRIDGE ACCESS POINT CUT SHEETS

(Listed as an option)

# ENH202

## Business Class, Outdoor, Long Range, 802.11b/g/n Bridge/Access Point



### Key Differentiators

#### DESIGNED FOR OUTDOOR DEPLOYMENTS

IP65 waterproof housing and cable accessory kit protects against moisture, rain and dew

#### DESIGN FOR OUTDOOR DEPLOYMENT WITH IP65 WATERPROOF HOUSING AGAINST MOISTURE, RAIN

Cable accessory kit prevents rain and dew getting into the device from cable connection

#### UP TO 300Mbps

Compliant with 802.11n standard for connection rate up to 300Mbps - 6x the speed of similar 802.11g devices and backward compatible to 11g

#### INTERNAL HIGH-GAIN 10dBi DIRECTIONAL ANTENNA

#### MULTIPLE SSIDS WITH VLAN BINDING

Permits different levels of network access when activating multiple SSID broadcasts. Individual SSIDs can be linked to existing VLANs to control user or department access

#### EASY TO DEPLOY

Includes signal strength LED indicators, pole mount and PoE injector kit

### Ideal For:

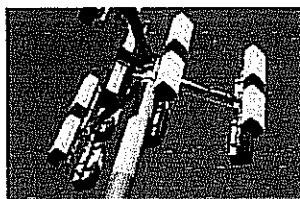

OUTDOOR WIFI  
OUTDOOR CPE

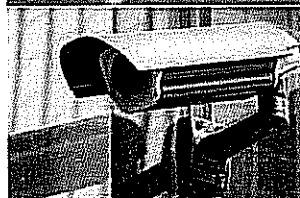

OUTDOOR WIRELESS  
IP SURVEILLANCE CAMERA



OUTDOOR WIRELESS  
SIGNAGE

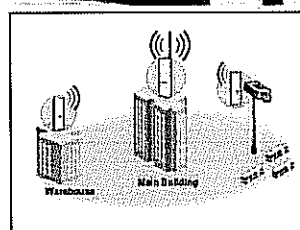

POINT-TO-MULTIPOINT  
COMMUNICATION

EnGenius®

# ENH202 – Technical Specifications

Specifications may change without notice.

## HARDWARE SPECIFICATIONS

MCU/RF	Atheros AR7240/AR9283
Memory	32 MB
Flash	8 MB
Physical Interface	10/100 Fast Ethernet port x 2 Reset button x 1
LED Indicators	Power Status LAN (10/100Mbps) WLAN (Wireless is up) 3 x Link Quality (Client Bridge mode)
Power Requirement	Active Ethernet (Power over Ethernet) Proprietary PoE design Power Adapter 24VAC / 0.6A

## RF SPECIFICATIONS

Wireless standard	IEEE802.11 b/g/n		
Frequency	2.412 ~ 2.472GHz (b/g/n)		
Modulation Technologies	IEEE 802.11b: DQPSK, DQPSK, CCK IEEE 802.11g: BQSK, QPSK, 16-QAM, 64-QAM IEEE 802.11n: BQSK, QPSK, 16-QAM, 64-QAM		
Operating Channels	11 channels		
Transmit Power	802.11b(2.412 ~ 2.472GHz)	802.11g(2.412 ~ 2.472GHz)	802.11n(2.412 ~ 2.472GHz)
	29 dBm @ 1Mbps 29 dBm @ 2Mbps 29 dBm @ 5.5Mbps 29 dBm @ 11Mbps	29 dBm @ 6Mbps 29 dBm @ 9Mbps 29 dBm @ 12Mbps 29 dBm @ 18Mbps 27 dBm @ 24Mbps 26 dBm @ 36Mbps 25 dBm @ 48Mbps 24 dBm @ 54Mbps	29 dBm @ MCS8 / MCS9 29 dBm @ MCS1 / MCS5 29 dBm @ MCS2 / MCS10 29 dBm @ MCS3 / MCS11 26dBm @ MCS4 / MCS12 25 dBm @ MCS5 / MCS13 24 dBm @ MCS6 / MCS14 23 dBm @ MCS7 / MCS15
Receiver Sensitivity	802.11b(2.412 ~ 2.472GHz)	802.11g(2.412 ~ 2.472GHz)	802.11n(2.412 ~ 2.472GHz)
	-97 dBm @ 1Mbps -95 dBm @ 2Mbps -92 dBm @ 5.5Mbps -89 dBm @ 11Mbps	-96 dBm @ 6Mbps -92 dBm @ 9Mbps -89 dBm @ 12Mbps -85 dBm @ 18Mbps -81 dBm @ 24Mbps -79 dBm @ 36Mbps -76 dBm @ 48Mbps -75 dBm @ 54Mbps	-95 dBm @ MCS8 / MCS9 -92 dBm @ MCS1 / MCS5 -87 dBm @ MCS2 / MCS10 -85 dBm @ MCS3 / MCS11 -80 dBm @ MCS4 / MCS12 -79 dBm @ MCS5 / MCS13 -74 dBm @ MCS6 / MCS14 -73 dBm @ MCS7 / MCS15
Antenna	Built-in 10dBi directional antenna ; Dual-polarity		

## SOFTWARE SPECIFICATIONS

Topology	Infrastructure, ad-hoc
Protocol	IEEE802.3, 802.3u, 802.11 b/g/n (2.4 GHz)
Operation Mode	Access Point/Client Bridge/WDS bridge/WDS AP/WDS ST/Client Router
LAN	DHCP server/client
VPN	VPN Pass-through
Networking	PPPoE, PPTP, DHCP client, spanning tree, Channel bandwidth
Security	WEP encryption – 64/128/152 bit WPA/WPA2 Personal (WPA-PSK uses TKIP or AES) WPA/WPA2 Enterprise (WPA-EAP usesTKIP) 802.1x Authenticator Hide SSID in beacons MAC address filtering, up to 50 fields Wireless STA (Client) connected list

## MANAGEMENT

Configuration	Web-based configuration
Firmware Upgrade	Firmware upgrade via browser
Administrator Setting	Administrator password change
Reset Setting	Reboot; Reboot to factory default
SNMP	V1, V2c
MIB	MIB I, MIB II(RFC1213), Private MIB
Backup & Restore	Configuration backup, configuration restore
Diagnosis	Ping & Trace Route,
Time Setting	Manual; Auto; NTP

## ENVIRONMENT & PHYSICAL

Temperature Range	Operation: -4°F ~ 158°F (-20°C ~ 70°C) Storage: -22°F ~ 176°F (-30°C ~ 80°C)
Humidity (non-condensing)	0%~90% typical
Dimensions	Length: 10.24" (260mm) Width : 3.31" (84mm) Height: 2.17" (55mm)
Weight	0.9 lb

## CONTENT OF PACKAGE - ENH202

- PoE Injector (EPE-24R)
- Power Adaptor
- CD with User's Manual
- QIG
- Mounting Set
- Special screw set

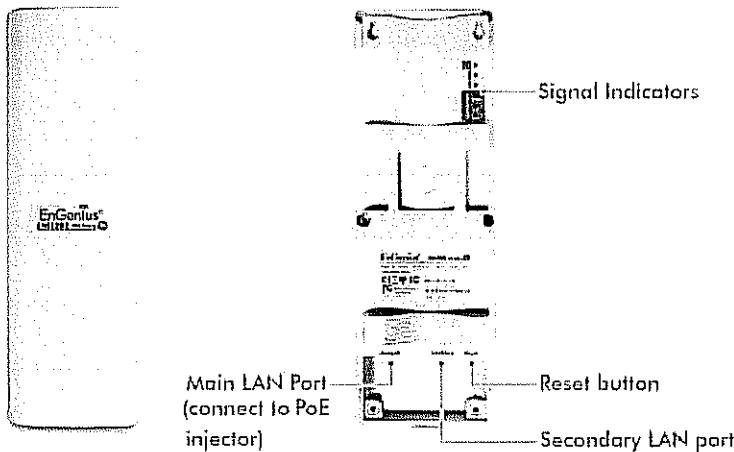

ENH202 H Polarization H Plane

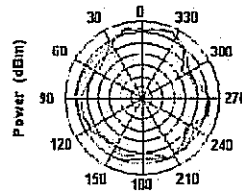

ENH202 H Polarization E Plane

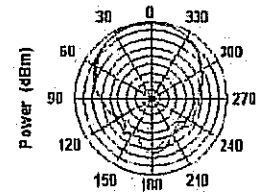

ENH202 V Polarization H Plane

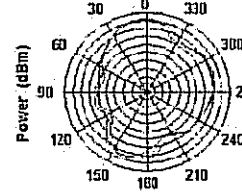

ENH202 V Polarization E Plane

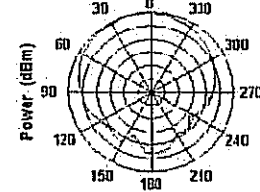

EnGenius Technologies 1580 Scenic Avenue • Costa Mesa, CA 92626, USA  
888.735.7888

EnGenius



## ENH202 Application Diagrams

### Introducing ENH202

*Business Class High-Speed Long Range Outdoor Wireless N Access Point/Client Bridge*

EnGenius ENH202 is a high power long range wireless Access point/bridge with 800mW power output and up to 300 Mbps max. wireless data rate.

Designed for outdoor application, the IP55 rated device is perfect for high-speed wireless network link, connecting IP camera or outdoor digital signs to office building hundreds or thousand apart.

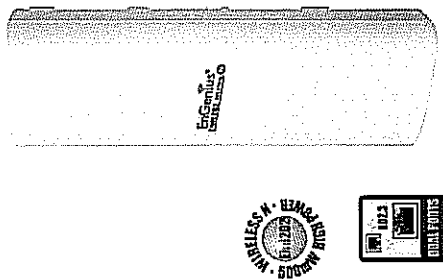

### Outdoor Wireless Point-to-Point Link Example Building-to-Building Wireless Connection

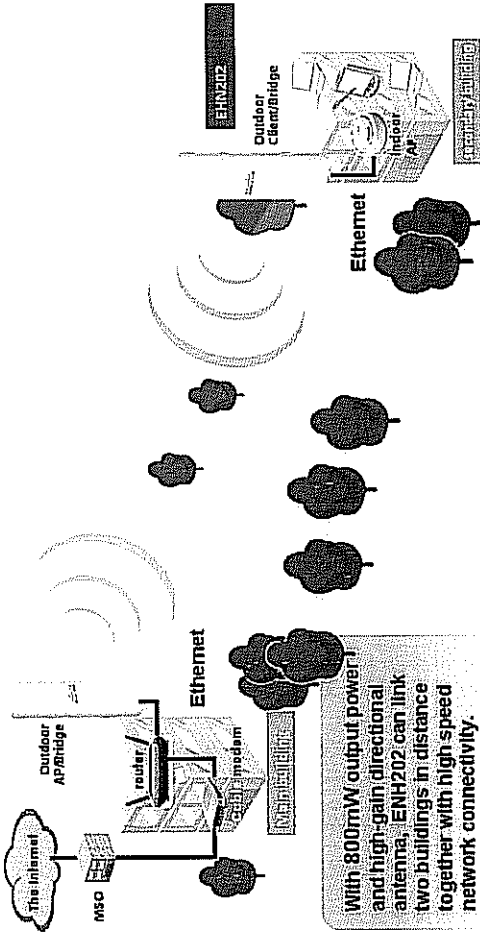

### Application 2 – Specialty wireless application

### Outdoor Digital Signage Wireless Connection

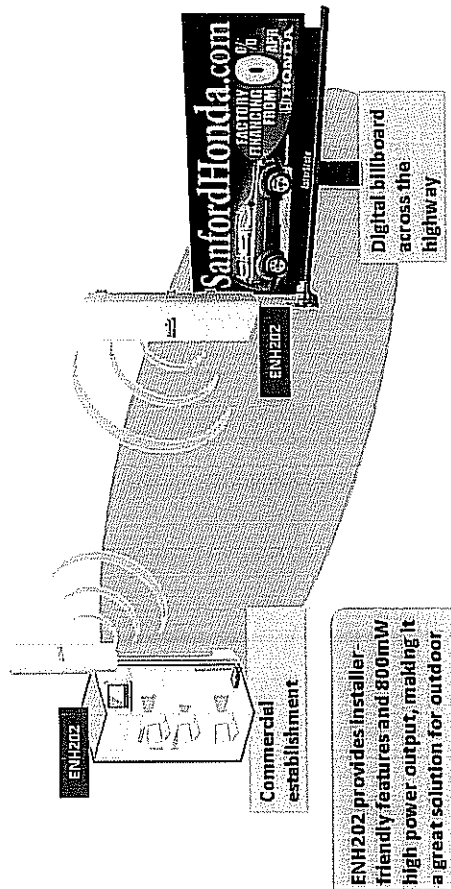

### Application 3 – Specialty wireless application

### Outdoor IP Security Camera Connection

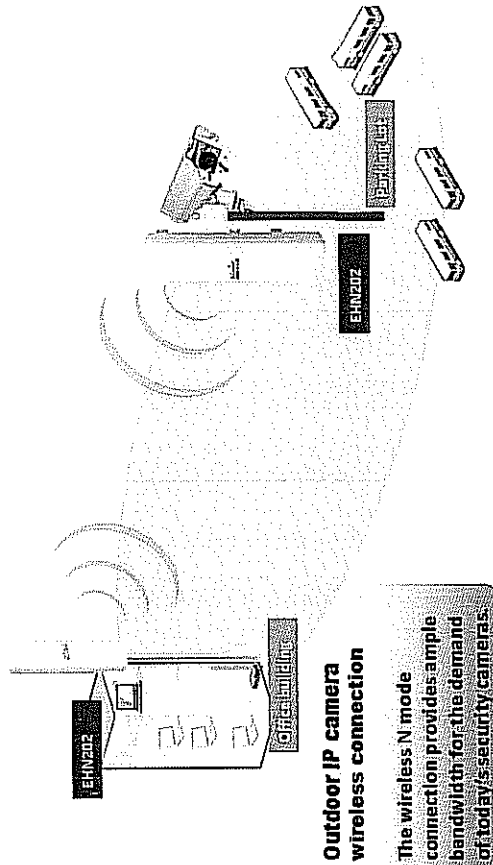

**AGENDA MEMO**

**City Council**

**April 15, 2013**

**ISSUE STATEMENT**

Adoption of a resolution temporarily waiving certain building permit fees.

**RESOLUTION**

**BACKGROUND/HISTORY**

At the April 1, 2013, Workshop Session, Mayor Weaver requested the temporary waiver of certain building permit fees be extended from December 1, 2013 to April 30, 2014. The City Council approved the building fee waiver at the March 18, 2013 City Council Meeting under Resolution No. R-23-13. The building fee holiday would continue to waive the building permit fees for residents and business property owners. Direct *out of pocket* expenses that are associated with the permit, such as Plan Review fees, would not be waived.

The staff has estimated that the City would reduce the budgeted revenue for building permit fees by \$35,000. This estimate is based on the applicable permit fees that were collected from May to April 30, 2012. Attached and labeled as [Exhibit A](#) is the proposed fee schedule for building permits related items which includes the recommended permit fees to be waived or not waived.

Below is the revised projection for the Building Permit Fee line item:

<b>ACCOUNT NUMBER</b>	<b>ACCOUNT DESCRIPTION</b>	<b>FY 13/14 BUDGET</b>	<b>PROPOSED REDUCTION</b>	<b>REVISED BUDGET</b>
01-00-3240	Building Permit Fees	\$ 35,000	\$ (35,000)	\$ 0

**COMMITTEE RECOMMENDATION**

This item was not reviewed before any Committee.

**ALTERNATE CONSIDERATION**

As directed by the City Council.

**DECISION MODE**

This item will be placed on the April 15, 2013 for formal consideration by the City Council.

**A RESOLUTION TEMPORARILY WAIVING BUILDING PERMIT FEES TO ENCOURAGE HOME IMPROVEMENTS, MAINTENANCE AND UPGRADES THROUGH APRIL 30, 2014**

**WHEREAS**, the City of Darien is a home rule unit of local government pursuant to the provisions of Article VII, Section 6, of the Illinois Constitution of 1970; and

**WHEREAS**, as a home rule unit of local government, the City may exercise any power and perform any function pertaining to its government except as limited by Article VII, Section 6; and

**WHEREAS**, the City of Darien Building Code assesses various permit fees; and

**WHEREAS**, in order to encourage home improvements on a short-term basis and assess the overall effectiveness of this program on a long-term basis, the City Council has determined it is in the best interests of the City to temporarily waive building permit fees for the current year; and

**WHEREAS**, with the home improvement season upon us, the City Council determines it is appropriate to now formalize and implement this policy direction;

**NOW, THEREFORE, BE IT RESOLVED BY THE CITY COUNCIL OF THE CITY OF DARIEN, DU PAGE COUNTY, ILLINOIS**, as follows:

**SECTION 1: “Building Permit Fees Waived” Declared.** The City Council hereby extends temporarily waiving building permit fees in order to encourage the improvements, maintenance and upgrade of dwellings within the City through April 30, 2014. This resolution hereby rescinds Resolution No. R-23-13 approved on March 18, 2013. No permit fees will be charged or assessed by the City for any of the categories of work for which a building permit is required as defined per [“Exhibit A”](#):

**SECTION 2: Other Permitting Requirements in Effect.** This temporary waiving of permit fees applies only to certain building permit fees. Building permits are still required for all work as designated by the City Code. Any person who fails to obtain a permit or permits work in violation of the building permit is subject to all fines and penalties as set forth in the City Code.

**SECTION 3: Effective Date; Sunset; Re-Evaluation.** This Building Permit Fee Waiver shall continue to be in effect to and including April 30, 2014. Thereafter, all fees as specified in the City Code shall resume in full force and effect.

**SECTION 4: Monitoring.** The City Administrator is hereby directed to monitor the cost and effectiveness of the Waiver of Building Permit Fees and report back to the City Council from time to

time.

**SECTION 5:** This Resolution and each of its terms shall be the effective legislative act of a home rule municipality without regard to whether such Resolution should (a) contain terms contrary to the provisions of current or subsequent non-preemptive state law, or (b) legislate in a manner or regarding a matter not delegated to municipalities by state law. It is the intent of the corporate authorities of the City of Darien that, to the extent the terms of this Resolution should be inconsistent with any non-preemptive state law, this Resolution shall supersede state law in that regard within its jurisdiction.

**SECTION 6:** This Resolution shall be in full force and effect from and after its passage and approval, and shall subsequently be published in pamphlet form as provided by law.

**PASSED BY THE CITY COUNCIL OF THE CITY OF DARIEN, DU PAGE COUNTY, ILLINOIS, this 15<sup>th</sup> day of April 2013.**

AYES: \_\_\_\_\_

NAYS: \_\_\_\_\_

ABSENT: \_\_\_\_\_

**APPROVED BY THE MAYOR OF THE CITY OF DARIEN, DU PAGE COUNTY, ILLINOIS, this 15<sup>th</sup> day of April 2013.**

\_\_\_\_\_  
KATHLEEN MOESLE WEAVER, MAYOR

ATTEST:

\_\_\_\_\_  
JOANNE E. RAGONA, CITY CLERK

APPROVED AS TO FORM:

\_\_\_\_\_  
CITY ATTORNEY

**MUNICIPAL SERVICES DEPARTMENT PERMIT FEE WAIVER SCHEDULE 3/19/13 – 12/31/13**

Permit Type	Permit Fee in Code	Outside Vendor Inspection Fees	Plan Review/ Bond Fee	Total Current Permit Fee	Permit Fee Holiday	Total Revised Permit Fee
Air Conditioner Replacement	\$50.00	\$25.00		\$75.00	(\$50.00)	\$25.00
Deck	\$50.00	\$0	\$115.00	\$165.00	(\$50.00)	\$115.00
Demolition	\$100.00	\$0		\$100.00	(\$100.00)	\$0
Driveways	\$75.00	\$0	\$175 refundable bond	\$250.00	(\$75.00)	\$175 refundable bond
Fence	\$25.00	\$0		\$25.00	(\$25.00)	\$0
Landscaping/Grading	\$50.00	\$0		\$50.00	(\$50.00)	\$0
Lawn sprinkler system	\$50.00	\$35.00		\$85.00	(\$50.00)	\$35.00
Patio – Cement or Paver brick	\$50.00	\$0		\$50.00	(\$50.00)	\$0
Roof	\$50.00	\$0		\$50.00	(\$50.00)	\$0
Private sidewalk/service walk	\$50.00	\$0		\$50.00	(\$50.00)	\$0
Shed	\$50.00	\$0		\$50.00	(\$50.00)	\$0
Parking Lots	\$100.00	\$0		\$100.00	(\$100.00)	\$0
Pool (above ground)	\$50.00	\$25.00	\$0	\$75.00	(\$50.00)	\$25.00

**PERMITS NOT UNDER CONSIDERATION FOR PERMIT FEE HOLIDAY**

	Permit Fee in Code	Outside Vendor Inspection Fee	Plan Review Fee	Total Fee
Water Tap On	\$1725.00	\$0	\$0	\$1725.00
Detached Garage	\$100.00	\$200.00	\$115.00	\$315.00*
Basement remodel (10,000) (avg)	\$150.00	\$270.00 (min)	\$115.00	\$385.00*
Sign Permits (avg)	\$260.00	(In permit fee)	\$65.00	\$325.00
Single Family Residence New (200,000) (avg)	\$2000.00	(In permit fee)	\$315.00	\$2315.00
Residential Additions (20,000) (avg)	\$200.00	\$270.00 (min)	\$215.00	\$485.00
Commercial, Office, Industrial Alteration/Buildout (220,000.00) (avg)	\$2700.00	(In permit fee)	\$650.00 (avg)	\$3350.00
<b>Inspection fees paid to outside vendors:</b>	Electric \$25.00 ea	Plumbing \$35.00 ea	All other residential \$50.00ea	All other commercial \$100.00 ea

\*When inspection fees paid to outside vendors exceeds the permit fees allowed under the code the greater fee is charged.

**AGENDA MEMO**  
**City Council**  
**April 15, 2013**

**ISSUE STATEMENT**

Resolution confirming City's intent to discontinue the funding of crossing guard services for District 61 beginning May 1<sup>st</sup>, 2014.

**RESOLUTION**

**BACKGROUND/HISTORY**

At the Police Committee meeting on May 3, 2012, the committee discussed a proposal from the Andy Frain Company to provide crossing guard services in place of part time city employees. The committee asked why the city pays for the crossing guards for district 61. I advised that we have paid for the crossing guards historically but was not aware of any intergovernmental agreement covering this. We do not pay for crossing guards for districts 63, 66, or private schools. The committee asked that, prior to any decision on the Andy Frain proposal, I contact school district 61 and ask that they take over the crossing guard services. Since the committee is a sub group of the city council I advised the full city council at the May 7, 2012 council meeting. School District 61's position is that crossing guard services are a police function and the expense to fund these services should be the city's responsibility.

During the FYE 14 budget meetings the city council continued the discussion on discontinuing the funding of crossing guard services for district 61. A majority of the aldermen (4 to 3) supported the city continuing to fund crossing guard services in FYE 14. During the April 4<sup>th</sup>, 2013 council meeting, the council approved the city budget but continued the discussion of discontinuing the funding of crossing guards in the **FYE 15** budget. Staff was directed to place this issue on the April 15, 2013 council meeting for formal consideration.

**STAFF RECOMMENDATION**

As directed by the council.

**ALTERNATE CONSIDERATION**

As directed by the council.

**DECISION MODE**

This item will be placed on the April 15, 2013, city council agenda for formal consideration.

**RESOLUTION STATING THE POSITION OF THE MAYOR AND CITY COUNCIL  
REGARDING THE  
CITY OF DARIEN'S FUNDING OF CROSSING GUARDS FOR SCHOOL DISTRICT 61**

**WHEREAS**, corporate boundaries of the City of Darien contain portions of 3 separate elementary/middle grade school districts including 61,63, and 66; and

**WHEREAS** the City of Darien currently pays for crossing guards for only one local school district, district 61; and

**WHEREAS** the city council has made a determination that local school districts have the responsibility for providing students with the ability to safely get to and from school, including funding crossing guard services if necessary; and

**WHEREAS**, the city council has determined that beginning May 1, 2014, the city will no longer fund crossing guards for District 61; and

**WHEREAS**, the city is giving over one year of notice so school district 61 has a reasonable period of time to plan for the funding and implementation of crossing guard services by May 1, 2014; and

**NOW, THEREFORE, BE IT RESOLVED THAT THE MAYOR AND CITY COUNCIL OF THE CITY OF DARIEN, DUPAGE COUNTY ILLINOIS**, as follows:

**SECTION ONE**, it is the intention of the Darien City Council to fund the District 61 crossing guards until April 30, 2014 and encourage district 61 to fund their crossing guard program beginning May 1, 2014; and

**SECTION TWO**, that the city administrator is directed to forward of certified copy of this resolution upon approval

**PASSED BY THE CITY COUNCIL OF THE CITY OF DARIEN, DU PAGE COUNTY, ILLINOIS**, this 15<sup>th</sup> day of April, 2013.

AYES: \_\_\_\_\_

NAYS: \_\_\_\_\_

ABSENT: \_\_\_\_\_

**APPROVED BY THE MAYOR OF THE CITY OF DARIEN, DU PAGE COUNTY,  
ILLINOIS, this 15th day of April, 2013.**

\_\_\_\_\_  
KATHLEEN MOESLE WEAVER, MAYOR

ATTEST:

\_\_\_\_\_  
JOANNE E. RAGONA, CITY CLERK

APPROVED AS TO FORM:

\_\_\_\_\_  
CITY ATTORNEY