

AGENDA
Municipal Services Committee
March 27, 2023
6:00 P.M. – Council Chambers

1. **Call to Order & Roll Call**
2. **Establishment of Quorum**
3. **Old Business**
4. **New Business**
 - a. **PZC2023-01 Noe (6805 Scotch Pine Trail)** - Petitioner seeks approval of a Variation from Section 5A-7-3-6 (A) of the Zoning Ordinance.
 - b. **Resolution** - Authorizing the disposal of surplus property.
 - c. **Resolution** - Authorizing the purchase of one new trailer, Model No. P8CAM164STTXW Tilt Trailer, from A&W Trailer LLC in the amount of \$15,039.
 - d. **Resolution** - Authorizing the purchase and delivery of one new sewer grate set, from L&G Welding Services, Inc., in the amount of \$7,060.
 - e. **Resolution** – Accepting a proposal from TAPCO for the purchase of a Pedestrian Crosswalk Signalization System for a mid-block crosswalk application at Clarendon Hills Road and Roger Road in an amount not to exceed \$11,779.02.
 - f. **Resolution** – Accepting a proposal from Dorner Company for the City’s water system in an amount not to exceed \$54,935 to re-build internal critical components of pump control valves and altitude valves.
 - g. **Resolution** – Waiving the competitive bid process and accepting a quote from Landmark Construction Services, Inc., for the City Hall Balcony Deck Remodel Project at 1702 Plainfield Road for the removal of the existing balcony and the material and installation of the replacement balcony deck, in an amount not to exceed \$85,000.00.
 - h. **Motion** - A contingency in the amount of \$5,000 due to unforeseen structural deficiencies items that may be encountered during the building construction.
 - i. **Minutes** – **February 27, 2023** Municipal Services Committee
5. **Director’s Report**
6. **Next scheduled meeting – April 24, 2023**
7. **Adjournment**

AGENDA MEMO
MUNICIPAL SERVICES COMMITTEE
MARCH 27, 2023

CASE

PZC2023-01

Variation (Rear Yard Setback)
 Don & Joan Noe – 6805 Scotch Pine Trail

ISSUE STATEMENT

Petitioners Don & Joan Noe seek approval of a variation request from Section 5A-7-3-6 (A) of the City Zoning Code to allow for an addition to an existing single-family residence, with the addition being a sunroom. Property is located within the R-3 Multi-Family Residence Zoning District and the Variation request is to the following standard in the R-3 District:

- Zoning Section 5A-7-3-6 (A): R-3 District Rear Yard Requirement.

GENERAL INFORMATION

Petitioner/Owner:	Don & Joan Noe
Property Location:	6805 Scotch Pine Trail
PIN Number:	09-22-301-038
Existing Zoning:	Multi-Family Residence District (R-3)
Existing Land Use:	Single Family
Comprehensive Plan:	Medium Density Residential (Existing/Future)
Surrounding Zoning & Uses	
North:	Multi-Family Residence District (R-3); Multi-Family
East:	Single Family Residence District (R-2); School
South:	Multi-Family Residence District (R-3); Single Family
West:	Multi-Family Residence District (R-3); Single Family
Size of Property:	0.29 Acres
Floodplain:	According to the DuPage County Parcel Viewer System, there is no floodplain on the subject site.
Natural Features:	N/A
Transportation:	The petition site gains access off Scotch Pine Trail, which is a private drive stemming from Bavarian Lane.

PETITIONER DOCUMENTS (ATTACHED TO MEMO)

- 1) **APPLICATION**
- 2) **JUSTIFICATION NARRATIVE**
- 3) **SITE PLAN**
- 4) **FLOOR PLAN**
- 5) **BUILDING ELEVATION**

CITY STAFF DOCUMENTS (ATTACHED TO MEMO)

- 6) **LOCATION MAP & AERIAL IMAGE**
- 7) **SITE PHOTOS**

PLANNING OVERVIEW/DISCUSSION

The subject property was platted in 1986 and is part of the Woodlands of Darien Subdivision. The parcel is improved with a single-family residence and unenclosed deck in the rear yard. The property is primarily flat and does not contain any natural features or floodplain. According to the submitted application and site plan, the petitioner is proposing a sunroom addition on the rear part of the residence where the deck is currently located.

The residence maintains a distance slightly greater than 30' from the rear property line (eastern lot line) while the existing deck is 18.2' from the rear lot line. The proposed sunroom would replace the deck and have a setback no less than 18.2' from the rear lot line. Given the property's zoning designation, which is R-3 Multi-Family Residence District, there is a required rear yard setback of 30'. Therefore, the petitioner has submitted this variation which requests approval to construct the sunroom resulting in an encroachment of 11.8'.

Site Plan Review & Findings of Fact

City staff has reviewed the petitioner submitted documents and staff does not have any review comments on the site plan. Additionally, the petitioner was asked to submit *Findings of Fact* that would support the requested variation. Those findings are attached to this memo under the submitted Justification Narrative.

PZC MEETING – 03/15/2023

The Planning and Zoning Commission reviewed this petition at its March 15, 2023 meeting. The petitioner was present and answered questions after staff's introduction of the case.

The Planning and Zoning Commission determined the case met the Decision Criteria and forwarded the case with a favorable recommendation to the Municipal Services Committee with a vote of 6-0, subject to the following conditions:

- 1) **The proposed deck location shown on the submitted site plan is compliant.**
- 2) **Applicant shall resubmit variance request if the project scope changes due to HOA denial.**

ALTERNATE CONSIDERATION

As recommended/directed by the Municipal Services Committee.

DECISION MODE

This item will be placed on the April 3, 2023 City Council agenda for formal consideration.



ZONING APPLICATION

RECEIVED

FEB 06 2023

Community Development
City of Darien

CITY OF DARIEN

1702 Plainfield Road, Darien, IL 60561

www.darienil.us 630-852-5000

CONTACT INFORMATION

Donald & Joan Noe

Applicant's Name

Donald & Joan Noe

Owner's Name

6805 Scotch Pine Trail, Darien, IL

Address, City, State, Zip Code

60561

6805 Scotch Pine Trail Darien, IL

Address, City, State, Zip Code

60561

815-718-2768 / 815-718-9193

Telephone

815-718-2768 / 815-718-9193

Telephone

noe.don6@gmail.com/noe.joan6@gmail.com

Email

noe.don6@gmail.com/noe.joan6@gmail.com

Email

PROPERTY INFORMATION

6805 Scotch Pine Trail

Property address

09-22-301-038

PIN Number(s)

R-3

Zoning District

Residential

Current Land Use(s)

(Attach additional information per the Submittal Checklist.)

REQUEST

Brief description of the zoning approval requested. (Contact the City Planner for guidance.)

[SEE ATTACHED LETTER]

Donald Noe

Applicant Signature

As Notary Public, in and for DuPage County in Illinois, I do hereby certify that Donald Noe is personally known by me to be the same person whose name is subscribed above and has appeared before me this day in person and acknowledged that they have signed this document as their own free and voluntary act, for the purposes therein set forth.

Given under my hand and seal, this 6 day of February 2023

For office use only	
Date Received:	02/06/23
Case Number:	PZC2023-01
Fee Paid:	\$360.00
Hearing Date:	03/15/23

Dorothy M. Hathaway
Notary Public



February 3rd, 2023

To The City of Darien and the Planning and Zoning Commission

We, Donald, and Joan Noe, are requesting a variance to the existing zoning standards for our home. We currently live at 6805 Scotch Pine Trail, located in the Woodlands subdivision.

Our specific request is for the approval of a zoning variance for our property so we may add a sunroom to the back of our home. Currently there is a deck occupying the space we would like to convert to a sunroom. Because our lot is quite shallow, this request would require us to impinge upon the required 30 feet of our lot line. From our perspective or knowledge, there is no other suitable or reasonable way to redesign the proposed improvements. As noted on the Platt survey, there is even less space available on the three other sides of the house.

There is no other option for us to expand our space, giving us the opportunity to enjoy the outside for all four seasons, instead of only summer with the existing deck. This request will not create a neighbor problem. As one can note, the back of our lot faces a street. Because of this location, there would be no infringement upon the outdoor space of a "backyard" neighbor. The current deck structure is at 18.2 feet from the lot line. The new sunroom will remain 18.2 feet from the lot line.

With the addition of the sunroom, even though it will be a variance from the typical 30 feet from the lot line, there is no foreseeable negative impact to the neighborhood due to the existing location of our home. The addition of this sunroom will enhance the aesthetic value of our home, and most importantly, provide us the opportunity to benefit from enjoying the outdoors year-round, and the health benefits it is known to offer seniors.

VARIATION CRITERIA

The variation request must address the following criteria for approval:

1. Whether the general character of the property will be adversely altered.
2. Whether the overall value of the property will be improved and there will not be any potential adverse effects on the neighboring properties.
3. Whether the alleged need for the variation has been created by any person presently having a proprietary interest in the premises.
4. Whether the proposed variation will impair an adequate supply of light and air in adjacent property, substantially increase congestion in the public streets, increase the danger of fire or endanger the public safety.
5. Whether the proposed variation will adversely alter the essential character of the neighborhood.

EXACTA

ILLINOIS SURVEYORS, INC.

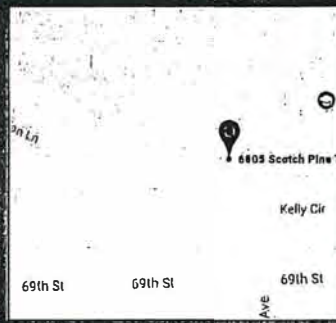

PROPERTY ADDRESS: 6805 SCOTCH PINE TRAIL DARIEN, ILLINOIS 60561

SURVEY NUMBER: IL1707.3294

FIELD WORK DATE: 7/24/2017

REVISION DATE(S): (REV.0 7/26/2017)

17073294
BOUNDARY SURVEY
DUPAGE COUNTY

LOT 23 IN WOODLANDS OF DARIEN, BEING A SUBDIVISION IN THE NORTHWEST 1/4 OF THE SOUTHWEST 1/4 OF SECTION 22, TOWNSHIP 38 NORTH, RANGE 11, EAST OF THE THIRD PRINCIPAL MERIDIAN, ACCORDING TO THE PLAT THEREOF RECORDED JULY 22, 1986 AS DOCUMENT R86-79970, IN DUPAGE COUNTY, ILLINOIS.

PROPOSED SUBROCKA

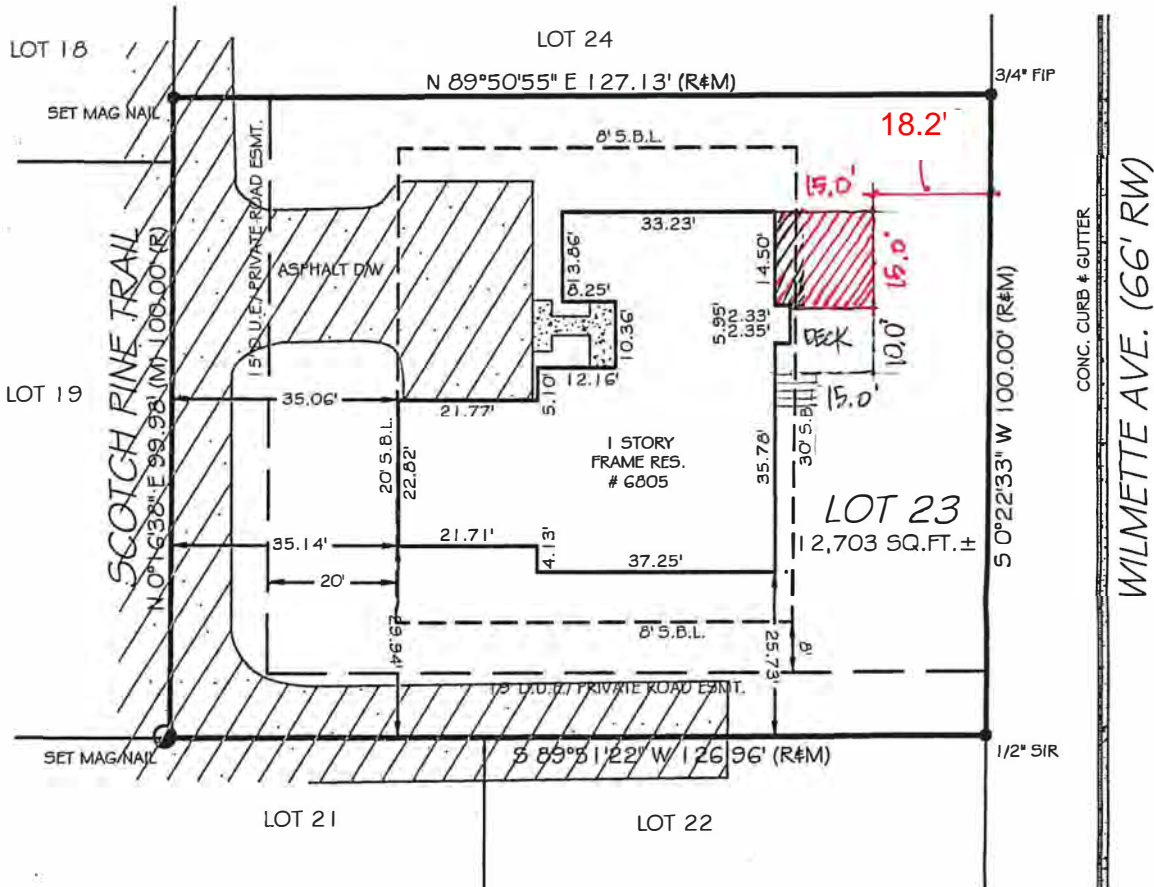

STATE OF ILLINOIS } ss
COUNTY OF DuPAGE

THIS IS TO CERTIFY THAT THIS PROFESSIONAL SERVICE CONFORMS TO THE CURRENT ILLINOIS MINIMUM STANDARDS FOR A BOUNDARY SURVEY. GIVEN UNDER MY HAND AND SEAL THIS 26TH DAY OF JULY, 2017 AT 312 S. HALE STREET IN WHEATON, IL 60187.

ILLINOIS PROFESSIONAL LAND SURVEYOR No. 2971
LICENSE EXPIRES 11/30/2018
EXACTA LAND SURVEYORS LB# 5763



GRAPHIC SCALE (In Feet)
1 inch = 30' ft.



THE ABOVE SURVEY IS A PROFESSIONAL SERVICE IN COMPLIANCE WITH THE MINIMUM STANDARDS OF THE STATE OF ILLINOIS. NO IMPROVEMENTS SHOULD BE MADE ON THE BASIS OF THIS PLAT ALONE. PLEASE REFER ALSO TO YOUR DEED, TITLE POLICY AND LOCAL ORDINANCES. COPYRIGHT BY EXACTA ILLINOIS SURVEYORS. THIS DOCUMENT MAY ONLY BE USED BY THE PARTIES TO WHICH IT IS CERTIFIED. PLEASE DIRECT QUESTIONS OR COMMENTS TO EXACTA ILLINOIS SURVEYORS, INC. AT THE NUMBER IN THE BOTTOM RIGHT CORNER.

POINTS OF INTEREST
NONE VISIBLE

CLIENT NUMBER: 17-125434

DATE: 7/26/2017

BUYER: CATHERINE CLIFFORD

SELLER: PAUL GAY

CERTIFIED TO: CATHERINE CLIFFORD; ADVISORS TITLE NETWORK;
MTEAM MORTGAGE GROUP

Exacta Proudly Supports
THE cara PROGRAM
transforming lives...
www.thecaraprogram.org

Since 1991, The Cara Program has placed more than 4,800 motivated adults into more than 8,000 quality jobs, catalyzing the same number of families to stop the transfer of poverty from one generation to the next.

EXACTA
ILLINOIS SURVEYORS, INC.

LB# 184005763

www.exactachicago.com
P: (773) 305-4010 • F: (773) 305-4011
316 East Jackson Street, Morris, IL 60450

NOE RESIDENCE

DARIEN, IL
01/31/23

9/1 2-2-23

THIS DESIGN CONCEPT DRAWING IS THE PROPERTY OF BRADFORD & KENT BUILDERS, INC. AND IS SOLELY INTENDED TO COMMUNICATE THE CONCEPT OF THE PROJECT TO THE CLIENT. THE ARCHITECTURAL WORKING DRAWINGS WILL DETERMINE FINAL DIMENSIONS, PROJECT DESIGN, AND SCOPE OF WORK. ALL DRAWINGS WILL BE SUBMITTED TO THE CLIENT FOR THEIR APPROVAL PRIOR TO CONSTRUCTION.

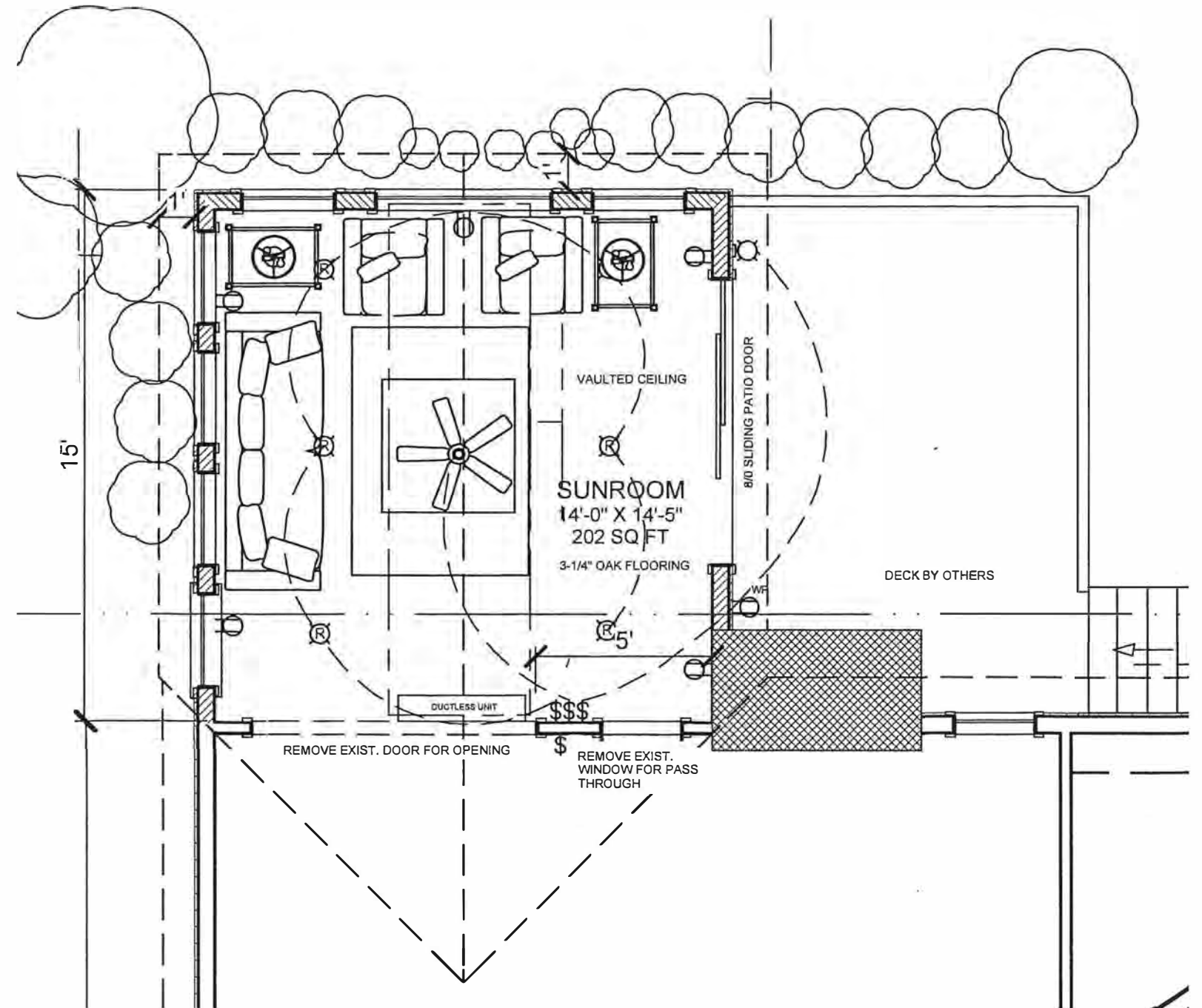

NOE RESIDENCE



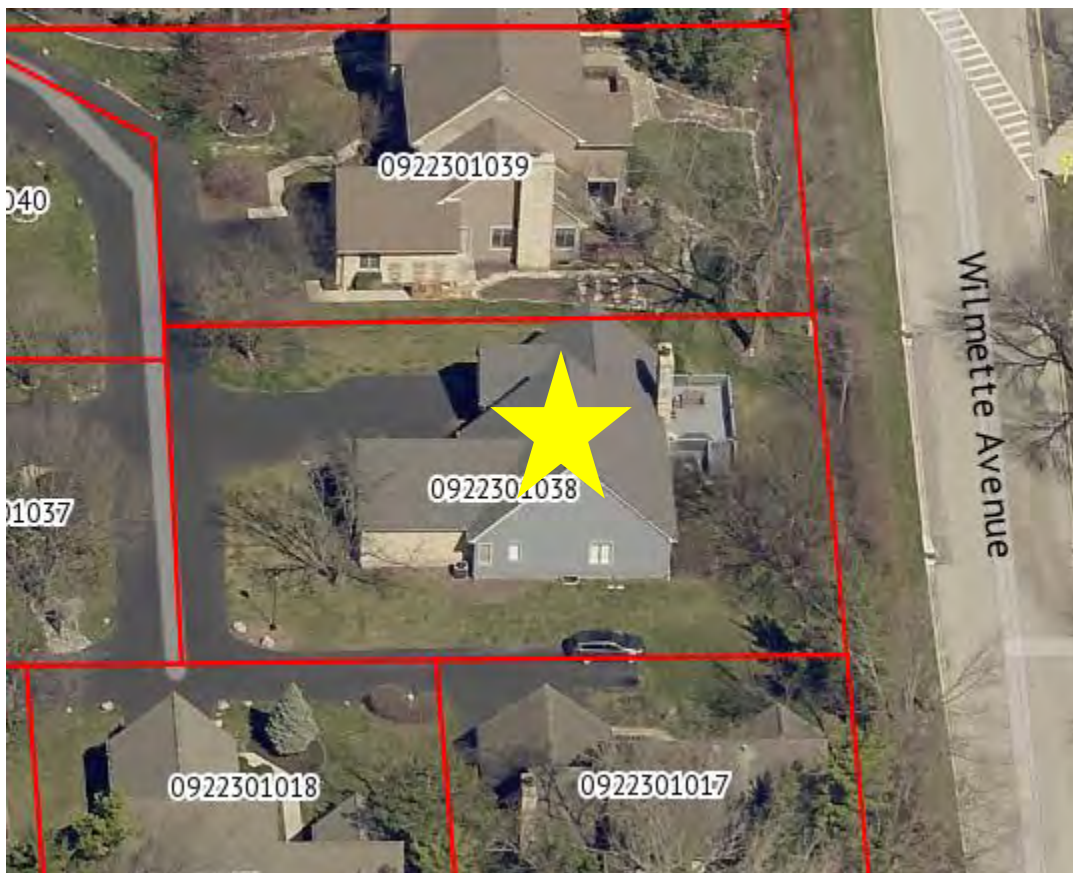
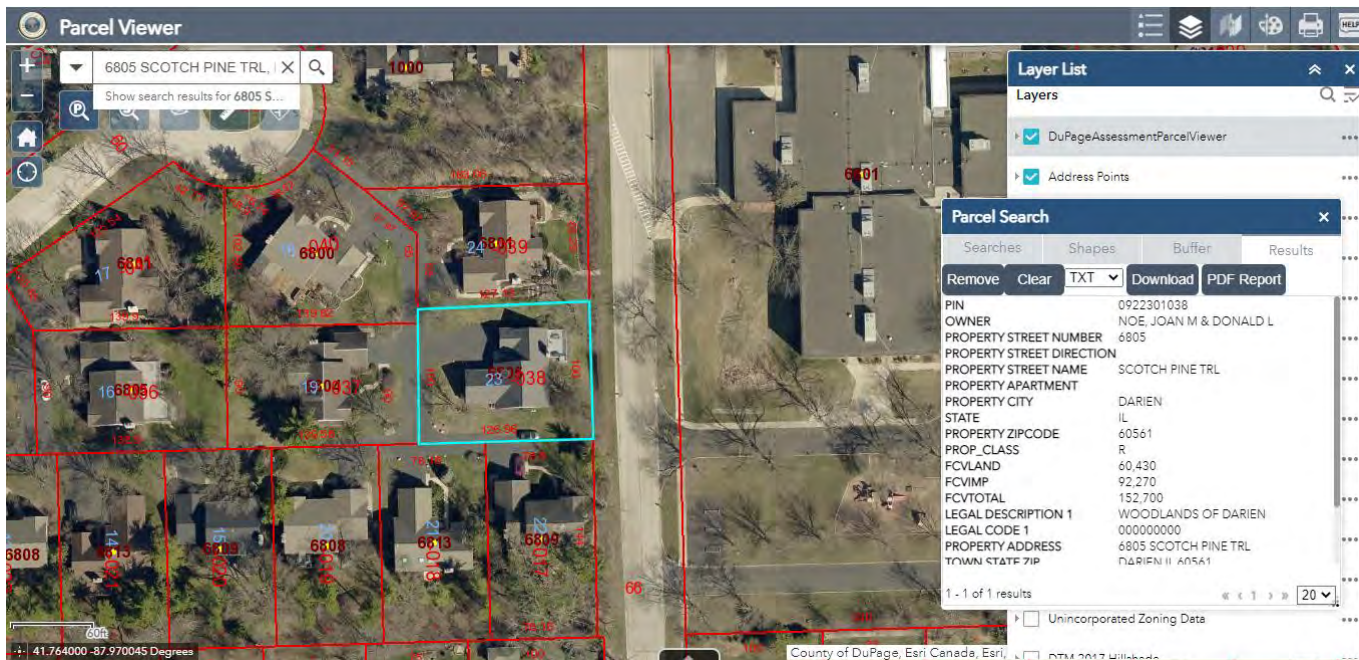





AGENDA MEMO
Municipal Services Committee
March 27, 2023

ISSUE STATEMENT

Approval of an [ordinance](#) authorizing the disposal of surplus property.

BACKGROUND/HISTORY

Staff is requesting that the following property be declared as surplus property and auctioned utilizing the services of GovDeals, Inc,

	ITEM	MODEL or VIN #	QUANTITY	EXPLANATION
1	Mohawk LMF-12 12,000lb vehicle lift	Serial #9101106	1	No Longer Serviceable
2	Honda EV6010 RV Generator – Gas	Serial #ECB-1014449	1	No Longer Needed
3	Reed Hydraulic Pipe Cutter UPC636	Serial #518 H	1	No Longer Needed
4	Wachs electric power valve turner	Serial #3116-270	1	No Longer Needed
5	Rex/Wheeler hydraulic pipe cutter	Serial #3890	1	No Longer Needed
6	Snap-On rolling tool chest w/side box		1	Replaced
7	Matco top drawer box	Serial #S11-00026	1	Replaced
8	Gatorcam w/camera & hose reel	Serial #70/GC2025R-512-8-689	1	Replaced
9	HP Laser Jet Printer	P1606dn	1	Replaced

Many of the above items may not have any value and pending auction results will be disposed of if not sold.

STAFF RECOMMENDATION

Staff recommends the approval of an ordinance authorizing approval of an ordinance authorizing the disposal of surplus property.

ALTERNATE CONSIDERATION

As recommended by the Committee.

DECISION MODE

This item will be placed on the April 3, 2023 City Council Agenda for formal approval.



CITY OF DARIEN

DU PAGE COUNTY, ILLINOIS

ORDINANCE NO. _____

**AN ORDINANCE AUTHORIZING THE SALE
OF PERSONAL PROPERTY
OWNED BY THE CITY OF DARIEN**

**ADOPTED BY THE
MAYOR AND CITY COUNCIL**

OF THE

CITY OF DARIEN

THIS 3rd DAY OF APRIL 2023

**Published in pamphlet form by authority
of the Mayor and City Council of the City
of Darien, DuPage County, Illinois, this
3rd day of April 2023.**

**AN ORDINANCE AUTHORIZING THE SALE
OF PERSONAL PROPERTY OWNED BY THE CITY OF DARIEN**

WHEREAS, in the opinion of at least three fourths of the corporate authorities of the City of Darien, it is no longer necessary or useful, or for the best interests of the City of Darien, to retain ownership of the personal property hereinafter described; and

WHEREAS, it has been determined by the Mayor and City Council of the City of Darien to sell said personal property at a Public Auction or dispose of said property.

NOW, THEREFORE, BE IT ORDAINED BY THE CITY COUNCIL OF THE CITY OF DARIEN, DU PAGE COUNTY, ILLINOIS, IN THE EXERCISE OF ITS HOME RULE POWERS, as follows:

SECTION 1: The Mayor and City Council of the City of Darien find that the following described personal property, now owned by the City of Darien, is no longer necessary or useful to the City of Darien and the best interests of the City of Darien will be served by auctioning it using Gov Deals, Inc or disposing of said property.

	ITEM	MODEL#	QUANTITY	EXPLANATION
1	Mohawk LMF-12 12,000lb vehicle lift	Serial #9101106	1	No Longer Serviceable
2	Honda EV6010 RV Generator – Gas	Serial #ECB-1014449	1	No Longer Needed
3	Reed Hydraulic Pipe Cutter UPC636	Serial #518 H	1	No Longer Needed
4	Wachs electric power valve turner	Serial #3116-270	1	No Longer Needed
5	Rex/Wheeler hydraulic pipe cutter	Serial #3890	1	No Longer Needed
6	Snap-On rolling tool chest w/side box		1	Replaced
7	Matco top drawer box	Serial #S11-00026	1	Replaced
8	Gatorcam w/camera & hose reel	Serial #70/GC2025R-512-8-689	1	Replaced
9	HP Laser Jet Printer	P1606dn	1	Replaced

ORDINANCE NO. _____

SECTION 2: The City Administrator is hereby authorized and directed to sell the aforementioned personal property, now owned by the City of Darien. Items will be auctioned using GovDeals, Inc or disposing of said property.

SECTION 3: This Ordinance and each of its terms shall be the effective legislative act of a home rule municipality without regard to whether such Ordinance should (a) contain terms contrary to the provisions of current or subsequent non-preemptive state law, or (b) legislate in a manner or regarding a matter not delegated to municipalities by state law. It is the intent of the corporate authorities of the City of Darien that to the extent that the terms of this Ordinance should be inconsistent with any non-preemptive state law, that this Ordinance shall supersede state law in that regard within its jurisdiction.

SECTION 4: This Ordinance shall be in full force and effect from and after its passage and approval as provided by law.

PASSED BY THE CITY COUNCIL OF THE CITY OF DARIEN, DU PAGE COUNTY, ILLINOIS, this 3rd day of April, 2023.

AYES: _____

NAYS: _____

ABSENT: _____

APPROVED BY THE MAYOR OF THE CITY OF DARIEN, DU PAGE COUNTY, ILLINOIS, this 3rd day of April, 2023.

JOSEPH MARCHESE, MAYOR

ATTEST:

JOANNE E. RAGONA, CITY CLERK

APPROVED AS TO FORM:

CITY ATTORNEY

AGENDA MEMO
Municipal Services Committee
March 27, 2023

ISSUE STATEMENT

A [resolution](#) authorizing the purchase of one new trailer, Model No. P8CAM164STTXW Tilt Trailer, from A&W Trailer LLC in an amount not to exceed \$15,039.

BACKGROUND/HISTORY

The existing trailer utilized within the Water Department, is approximately 22 years in age and has served its useful life. The trailer continues to rust and the metal is fatiguing in locations.

Attached as [Attachment A](#) is the rating sheet.

Staff requested competitive quotes for the trailer and received three quotes. Below, please find the results of the competitive quotes for the trailer.

VENDOR	COST
A &W Auto Truck Trailer	\$ 15,039
Knapheide Equipment Co.	\$ 15,542
Detro Trailers LLC	\$ 16,475

The lead time for the trailer is approximately 6-8 weeks.

The FY23/24 budget included funding for the proposed trailer and would be expended from the following account:

ACCOUNT NUMBER	ACCOUNT DESCRIPTION	FY 23-24 BUDGET	PROPOSED EXPENDITURE	PROPOSED BALANCE
02-50-4815	Capital Purchases-Equipment	\$ 20,000	\$ 15,039	\$ 4,961

STAFF RECOMMENDATION

Staff recommends approval of a resolution authorizing the purchase of one (1) new trailer, Model No. P8CAM164STTXW Tilt Trailer, from A&W Truck Trailer LLC in an amount not to exceed \$15,039

ALTERNATE CONSIDERATION

As directed by the Committee.

DECISION MODE

This item will be placed on the April 3, 2023 City Council agenda for formal consideration. .

CRITERIA FOR REPLACING CITY VEHICLES AND EQUIPMENT

UNIT NO	411	DEPARTMENT	Water	DATE	
MODEL YEAR	2001	MODEL	Trailer		3-19-23
CURRENT MILEAGE		CURRENT HOURS	None		
			MAXIMUM POINTS	VEHICLE SCORE	
AGE					
	Department		Water		
	Life Expectancy		15		
	Age as of Report Date		22		
	AGE: Meets Requirements		20		20
USAGE					
	MILES				
	HOURS		None		
	ATTACHMENT C OF THE VEHICLE REPLACEMENT POLICY				
	USAGE: Meets Requirements		20		20
TYPE OF SERVICE					
	1-LIGHT DUTY				
	10-CRITICAL DUTY				
	SERVICE: Meets Requirements		15		5
RELIABILITY					
	RELIABILITY: Frequency or Visits for Service				
	RELIABILITY: Meets Requirements		15		10
MAINTENANCE AND REPAIR COSTS					
	REPAIRS: Cost per Mile/Hours Exceeds Vehicle in Class				
	ORIGINAL PURCHASE PRICE		unknown		
	LIFE TO DATE REPAIR COST		0		
	PERCENTAGE OF REPAIRS TO PURCHASE PRICE		0		

UNIT NO	411	DEPARTMENT		DATE	
MODEL YEAR		MODEL			
CURRENT MILEAGE		CURRENT HOURS			
			MAXIMUM POINTS	VEHICLE SCORE	
PERCENTAGES OF REPAIR POINTS	POINTS				
1 THROUGH 20	2				
21 THROUGH 40	4				
41 THROUGH 60	6				
61 THROUGH 80	8				
81 THROUGH 100	10				
	REPAIRS: Meets Requirements		10		0
CONDITION:					
	CONDITION OF ENGINE COMPONENTS (MAJOR REPAIRS NEEDED OR ANTICIPATED), BODY (BODY SHEET METAL RUSTED, STRUCTURAL COMPONENTS)				
	CONDITION: Meets Requirements		15		15
TECHNOLOGICAL ADVANCEMENTS	FUEL EMISSIONS, SAFETY FEATURES, ERGONOMICS		5		5
TOTAL POINTS			100		75

CITY OF DARIEN
 Repair Transaction Cost Detail

Equipment#	Repair Order#	Date	Meter(1)	Shop Loc/ Rep Class	Rep Reason/ Rep Site			
411	0000028883	06/30/10	(off)	01/01	08/01			
	<u>Group-System</u>			<u>Mech/Vendor</u>	<u>Work Acc</u>	<u>Part(\$)</u>	<u>Labor(\$)</u>	<u>Hours</u>
	01-PMC - PREV. MAINT.			001		0.00	14.00	0.50
411	0000029121	01/17/11	(off)	01/01	08/01			
	01-PMC - PREV. MAINT.			002		0.00	3.75	0.25
411	0000029373	08/19/11	(off)	01/01	08/01			
	01-PMC - PREV. MAINT.			002		0.00	3.75	0.25
411	0000029672	03/23/12	(off)	01/01	08/01			
	01-PMC - PREV. MAINT.			002		0.00	7.50	0.50
411	0000030012	12/20/12	(off)	01/01	08/01			
	01-PMC - PREV. MAINT.			002		0.00	7.50	0.50
				<u>Grand Total</u>		<u>0.00</u>	<u>36.50</u>	<u>2.00</u>

RESOLUTION NO. _____

**A RESOLUTION AUTHORIZING THE PURCHASE OF ONE NEW TRAILER,
MODEL NO. P8CAM164STTXW TILT TRAILER, FROM A&W TRAILER LLC
IN THE AMOUNT OF \$15,039**

**BE IT RESOLVED BY THE CITY COUNCIL OF THE CITY OF DARIEN, DU
PAGE COUNTY, ILLINOIS**, as follows:

SECTION 1: The City Council of the City of Darien hereby authorizes the purchase of one new trailer, Model No. P8CAM164STTXW Tilt Trailer, from A&W Trailer LLC in an amount not to exceed \$15,039, copy of which is attached hereto as "[Exhibit A](#)".

SECTION 2: This Resolution shall be in full force and effect from and after its passage and approval as provided by law.

**PASSED BY THE CITY COUNCIL OF THE CITY OF DARIEN, DU PAGE
COUNTY, ILLINOIS**, this 3rd day of April, 2023.

AYES: _____

NAYS: _____

ABSENT: _____

**APPROVED BY THE MAYOR OF THE CITY OF DARIEN, DU PAGE COUNTY,
ILLINOIS**, this 3rd day of April, 2023.

JOSEPH MARCHESE, MAYOR

ATTEST:

JOANNE E. RAGONA, CITY CLERK

APPROVED AS TO FORM

CITY ATTORNEY

A&W Trailer LLC
 17W411 N. Frontage Rd.
 Darien, IL 60561
 630-964-8897

TRAILER QUOTE

Date	Estimate #
2/24/2023	624

Name / Address
CITY OF DARIEN 1041 S. FRONTAGE DARIEN, IL 60561 630-514-5602

Description	Qty	Rate	Total	P.O. No.	Project	PROJECT
CAM SUPERLINE		14,799.00	14,799.00T			
TRADE IN		0.00	0.00			
LICENSE/TRANSFER "M PLATE"		10.00	10.00			
TITLE OR TRANSFER OF TITLE		155.00	155.00			
DOC FEE		50.00	50.00T			
ELECTRONIC FILE FEE		25.00	25.00T			
VIN#		0.00	0.00			
MODEL P8CAM164STTXW (16' TILT 4' FLAT)		0.00	0.00			
2023		0.00	0.00			
		0.00	0.00			
ALL DEPOSITS ARE NON REFUNDABLE.		0.00	0.00			
ALL CHECKS ARE SUBJECT AT ADVANCE APPROVAL.						
DELAYS IN SHIPPING AND BUILD TIMES ARE NOT THE RESPONSIBILITY OF A&W TRAILER LLC.						
TRAILER SALE			15,039.00			
LEAD TIMES ARE 6-8 WEEKS						
				Subtotal		\$15,039.00
FAX # 630-964-4644				EMAIL; AWTRAILER@GMAIL.COM		Sales Tax (0.0%) \$0.00
				Total		\$15,039.00

AGENDA MEMO
Municipal Services Committee
March 27, 2023

ISSUE STATEMENT

A [resolution](#) authorizing the purchase and delivery of one new sewer grate set, from L&G Welding Services, Inc., in an amount not to exceed \$7,060.

BACKGROUND/HISTORY

The proposed grate would be utilized to replace an existing grate in Pinewood Park adjacent to Portsmouth Drive. The grate serves as an outfall to an underground storm sewer infrastructure. The grate continues to collect upstream debris, tree branches, leaves, mowed turf clippings and general trash. During the significant rain events as the grate becomes restricted the surrounding area is inundated with localized street flooding on Portsmouth along with adjacent properties. While the Department maintains the grates prior to and post rain events, heavy equipment is required to remove the grate during the event to allow storm water to recede and remove the debris from the grate. Staff proposes replacing the existing grate with a more suitable grate that will trap less material and allow for more efficient maintenance.

Staff requested competitive quotes for the drainage grates and received two responses. Below, please find the results of the competitive quotes for the grates.

VENDOR	COST
L&G Welding Services, Inc.	\$ 7,060.00
Oostman Fabricating & Welding, Inc.	\$ 18,872.70
D & B Fabricators	No response

The FY22/23 budget included funding for the grates and would be expended from the following account:

ACCOUNT NUMBER	ACCOUNT DESCRIPTION	FY 22-23 BUDGET	PROPOSED EXPENDITURE	PROPOSED BALANCE
01-30-4374	Drainage Projects	\$ 22,500	\$ 7,060	\$ 15,440

STAFF RECOMMENDATION

Staff recommends approval of a resolution authorizing the purchase and delivery of one new sewer grate set, from L&G Welding Services, Inc., in the amount of \$7,060.

ALTERNATE CONSIDERATION

As directed by the Committee.

DECISION MODE

This item will be placed on the April 3, 2023 City Council agenda for formal consideration. .



RESOLUTION NO. _____

A RESOLUTION AUTHORIZING THE PURCHASE AND DELIVERY OF ONE NEW SEWER GRATE SET, FROM L&G WELDING SERVICES, INC., IN THE AMOUNT OF \$7,060

BE IT RESOLVED BY THE CITY COUNCIL OF THE CITY OF DARIEN, DU PAGE COUNTY, ILLINOIS, as follows:

SECTION 1: The City Council of the City of Darien hereby authorizes the purchase and delivery of one new sewer grate set, from L&G Welding Services, Inc., in the amount of \$7,060, a copy of which is attached hereto as "[Exhibit A](#)".

SECTION 2: This Resolution shall be in full force and effect from and after its passage and approval as provided by law.

PASSED BY THE CITY COUNCIL OF THE CITY OF DARIEN, DU PAGE COUNTY, ILLINOIS, this 3rd day of April 2023.

AYES: _____

NAYS: _____

ABSENT: _____

APPROVED BY THE MAYOR OF THE CITY OF DARIEN, DU PAGE COUNTY, ILLINOIS, this 3rd day of April 2023.

JOSEPH MARCHESE, MAYOR

ATTEST:

JOANNE E. RAGONA, CITY CLERK

APPROVED AS TO FORM

CITY ATTORNEY



ESTIMATE

L&G Welding Services, Inc
 64 Devonwood Ave
 Romeoville, IL 60446

info@lgweldingservicesinc.com
 +1 7794359807
 lgweldingservicesinc.com



City of Darien

Bill to

City of Darien
 Jeff Corneils
 1401 S Frontage Rd
 Darien, IL 60561

Estimate details

Estimate no.: 1003

	Product or service	Amount
1.	Parts 11'6"x4'9" and 39"x39" sewer metal guards fabrication and deliver to painting and job location	1 unit × \$2,200.00 \$2,200.00
2.	Parts 1 1/2" SCH40 Galvanized pipe	15 units × \$270.00 \$4,050.00
3.	Parts 3/8x2"x20' Galvanized flat bar	3 units × \$270.00 \$810.00
4.	Repair Service	\$0.00
5.		\$0.00
6.		\$0.00
7.	tax exempt E99974487	\$0.00
	Total	\$7,060.00

AGENDA MEMO
Municipal Services Committee
March 27, 2023

ISSUE STATEMENT

A [resolution](#) accepting a proposal from TAPCO for the purchase of a Pedestrian Crosswalk Signalization System for a mid-block crosswalk application at Clarendon Hills Road and Roger Road in an amount not to exceed \$11,779.02.

BACKGROUND/HISTORY

In 2017, The City commissioned Kenig, Lindgren, O'Hara, Aboona, Inc. (KLOA), traffic engineering consultants, to provide a study for the pedestrian crosswalk. See [Attachment A](#), for the full report.

In summary the study area segment of Clarendon Hills Road carries approximately 11,700 vehicles per day and is comprised primarily of automobiles and small vans. The common peak hour when traffic levels were the highest were between 4:45pm and 5:45pm. The report further suggests that Community Park has a high use between the hours of 3:00pm and 6:00pm Monday through Friday.

The study concludes a mid-block pedestrian crossing on Clarendon Hills Road is not warranted. The conclusion is based on Transit Cooperative Research Program (TCRP) 112/National Cooperative Highway Research Program (NCHRP) 562 guidelines and Institute of Transportation Engineers (ITE) criteria. Guidance from the Manual on Uniform Traffic Control Devices, MUTCD, however, leaves the determination on the appropriateness of a crosswalk on the findings of an engineering study, which is represented by the attached report. Based on the gathered information, the City could install the crosswalk, and it is recommended to be installed at Roger Road.

The recommendation is contingent upon the installation of several supplemental measures that will increase pedestrian safety, improve visibility of the crossing to motorists, calm traffic speeds, and draw pedestrians to the crosswalk instead of crossing Clarendon Hills Road at other unmarked locations. These measures include a raised refuge island, pedestrian crossing signs, advance pedestrian crossing and/or Park Zone signs, and sidewalk extensions and relocations.

Staff has partnered with TAPCO to build the pedestrian signal unit for our application and is further discounted through the OMNIA Partners, Public Sector Partnership; Contract #2020-200. See [Attachment B](#). The proposed expenditure would be expended from the following account:

ACCOUNT NUMBER	ACCOUNT DESCRIPTION	FY 22/23 BUDGET	EXPENDITURE
25-35-4380	Capital Pedestrian Signal	\$15,000.00	\$11,229.02
25-35-4380	Capital Pedestrian Signal Estimated Shipping		\$ 500.00
	TAPCO TOTAL		\$11,779.02
25-35-4380	Electric, Signage, Misc.		\$ 3,200.00
TOTALS		\$15,000.00	\$14,929.02

STAFF RECOMMENDATION

Staff recommends approval of a resolution accepting a proposal from TAPCO for the purchase of a Pedestrian Crosswalk Signalization System for a mid-block crosswalk application at Clarendon Hills Road and Roger Road in an amount not to exceed \$11,779.02.

ALTERNATE CONSIDERATION

As recommended by the Municipal Services Committee.

DECISION MODE

This item will be placed on the April 3, 2023 City Council agenda for formal consideration.

MEMORANDUM TO: Daniel Gombac
City of Darien

FROM: Michael A. Werthmann, PE, PTOE
Principal

DATE: September 19, 2017

SUBJECT: Evaluation of Midblock Crosswalk Location
71st Street at Community Park
Darien, Illinois

This memorandum provides a summary of an evaluation performed by Kenig, Lindgren, O'Hara, Aboona, Inc. (KLOA, Inc.) regarding the most appropriate location for a midblock crosswalk on 71st Street serving Community Park. Community Park is located on the west side of Clarendon Hills Road between Plainfield Road and 71st Street. The park currently has one pedestrian entrance on 71st Street which is located at the western end of the park approximately 760 feet west of Clarendon Hills Road. 71st Street is a residential collector road that has one lane in each direction and is under stop sign control at its intersection with Clarendon Hills Road and all-way stop sign control at its intersection with Bentley Avenue. Parking is generally permitted on both sides of the road.

If the City desires to install a midblock crosswalk, the most appropriate location is at the pedestrian entrance at the western end of the park given the following:

- This location will provide direct access to the only pedestrian entrance along 71st Street. A pedestrian entrance is located on Clarendon Hills Road just south of 71st Street. However, this pedestrian entrance is served via the existing crosswalk on 71st Street at Clarendon Hills Road.
- Given the existing crosswalk at Clarendon Hills Road, the preferred midblock crosswalk location will result in crosswalks at both the east and west ends of the park which (1) provides optimal access to/from the entire park and (2) better serves the neighborhood.

If the midblock crosswalk is installed, it should be designed as illustrated in **Figure A** and summarized below:

- The midblock crosswalk should consist of a high visibility ladder style crosswalk.
- In order to reduce the crossing distance, enhance the pedestrian visibility, improve the pedestrian sight lines, and to install traffic calming along 71st Street, curb extensions should be installed on both the north and south sides of 71st Street serving the midblock crosswalk. The curb extension can be provided via striping and bollards or, preferably, raised concrete extensions.

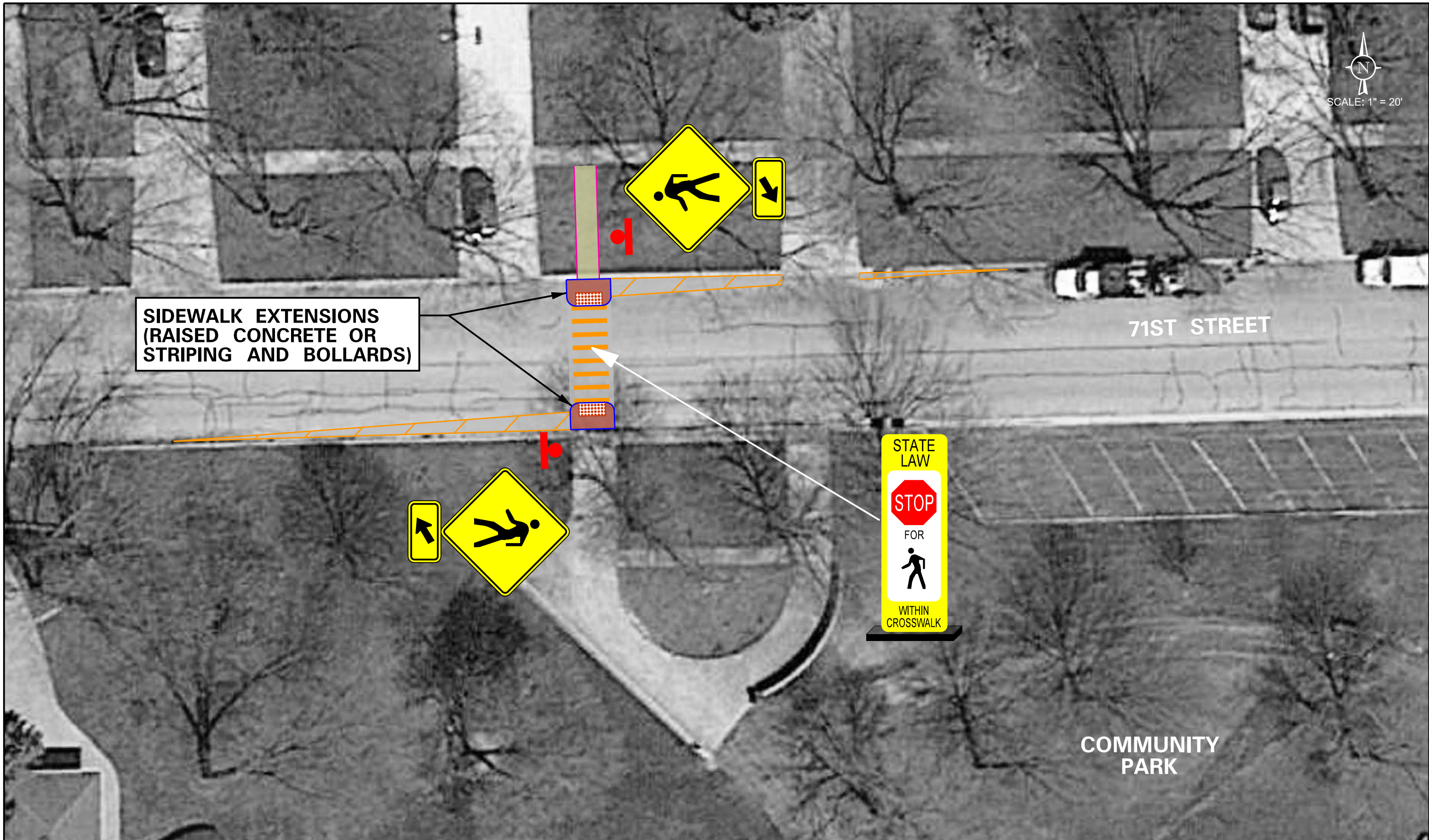

SIDEWALK EXTENSIONS
(RAISED CONCRETE OR
STRIPING AND BOLLARDS)

71ST STREET

COMMUNITY
PARK

- With or without curb extensions, on-street parking should be restricted a minimum of 10 feet on both the east and west sides of the midblock crosswalk on both sides of 71st Street. With the curb extensions, the parking restrictions could be implied with edge line channelization as shown in Figure A. Without the curb extensions, the parking restrictions should be posted with “No Parking” signs.
- Two-sided “Pedestrian Crossing Warning” signs (W11-2) with diagonal downward pointing arrow plaques (W16-7P) should be installed on both the north and south sides of 71st Street at the crosswalk.
- An “In-Street Pedestrian Crossing” Sign (R1-6A) can be utilized within the middle of the crosswalk indicating that it is a State Law that vehicles stop for pedestrians within the midblock crosswalk. The sign can be removed during the winter months to avoid damage by snow plows.
- Additional sidewalk with ADA ramps will need to be installed along the north side of 71st Street connecting the existing sidewalk system to the proposed midblock crosswalk.

An engineer’s opinion of probable costs was developed by Christopher B. Burke Engineering, Ltd. and is provided in a separate letter.



TAPCO® | **OMNIA**®
Safe travels.® | PARTNERS
Public Sector Partnership

VALUE OF WORKING WITH OMNIA PARTNERS, PUBLIC SECTOR

OMNIA Partners, Public Sector is the nation's largest and most experienced cooperative purchasing organization for public sector procurement, working with over 90,000 cities, counties, municipalities, state agencies, higher education institutions and more.

With OMNIA Partners, Public Sector, you get a viable contract that enables you to purchase equally, regardless of size. You also get vetted vendors, no annual cost, free freight, a faster and smoother procurement process and competitive pricing on thousands of products. This includes over 18,000 TAPCO products, from cones to barricades to delineators and more.



WHAT TAPCO HAS TO OFFER

As an industry-leading innovator serving the United States and beyond, TAPCO manufactures, services and distributes a wide portfolio of traffic and parking safety solutions designed to increase safe travels for all. Since 1956, we have set the standard for delivering reliable, cutting-edge traffic safety enhancements.

From our world-renowned line of LED-enhanced BlinkerSign® solutions to our pedestrian crossing products and early detection warning systems, safety is at the heart of all TAPCO innovations.

TAPCO & OMNIA PARTNERS, PUBLIC SECTOR PROGRAM

Contract #2020-200

5-year initial term, March 1, 2020 – February 28, 2025

Option to renew for five additional one-year periods

Lead Agency: Barron County, WI

Eligible Agencies:

- States and state agencies
- Public and private primary education institutions
- Public and private higher education institutions
- Special districts
- Cities, counties and municipalities
- Nonprofits and charitable organizations

POPULAR CONTRACT SOLUTIONS

24/7 FLASHING ALERTS & STATIC SIGNS

- Standard and custom flashing signs
- Flashing red and amber beacons
- MUTCD-compliant static signs

PEDESTRIAN SAFETY SOLUTIONS

- Pedestrian crosswalk systems
- In-road warning lights
- SafeWalk® Crosswalk Illuminator
- Delineator posts

DRIVER AWARENESS SOLUTIONS

- Wrong-way alert systems
- Curve warning systems
- Dynamic message signs
- Overheight warning systems

WORK ZONE SAFETY SOLUTIONS

- Message boards
- Barricades and traffic cones
- Truck-mounted attenuators
- Channelizers

SCHOOL ZONE WARNING SOLUTIONS

- Programmable flashing beacons
- School speed limit flashing signs
- Driver feedback signs

PARKING SOLUTIONS

- License plate recognition systems
- SmartPark management software
- Card readers
- Blankout signs

REQUEST A CUSTOM QUOTE



Visit: tapconet.com

Call: (800) 236-0112





 **TAPCO**[®]
Safe travels.[®]

 (800) 236-0112  TAPCOnet.com

OMNIA Partners Government Purchasing Alliance Contract Provides Traffic Control Products & Solutions at Best Value Pricing

TAPCO was competitively solicited and publicly awarded a national cooperative contract for traffic and parking solutions by Barron County, Wisconsin, which is made available through OMNIA Partners, Public Sector (subsidiary U.S. Communities) Contract #2020-200

Who is OMNIA Partners, Public Sector?

OMNIA Partners, Public Sector is the nation’s largest and most experienced cooperative purchasing organization dedicated to public sector procurement. Their immense purchasing power have produced a comprehensive portfolio of cooperative contracts and partnerships, making OMNIA Partners, Public Sector the most valued and trusted resource for organizations nationwide.

Why OMNIA Partners, Public Sector?

Through the economies of scale created by OMNIA Partners, Public Sector, our participants now have access to an extensive portfolio of competitively solicited and publicly awarded agreements. The lead agency contracting process continues to be the foundation on which we are founded. OMNIA Partners, Public Sector offers value and resources to state and local government, higher education, K-12 education and non-profits.

Purchases made through contract #2020-200:

- Have reduced administrative and time costs related to the bid solicitation process
- Feature exclusive discounted pricing on more than 18,500 TAPCO products
- Sponsored by more than 90 state and regional organizations
- Public purchasing professional oversight
- Approved products and pricing

Generally, the following agencies are eligible:

- Counties, Cities, Towns and Villages
- State Agencies
- Public Schools (K-12, Colleges and Universities)
- Nonprofit Organizations (including private K-12 Schools)

To enroll or order: contact your TAPCO representative

Phone: (855) 437-5535

Email: OMNIAPartners@tapconet.com

URL: <https://www.omniapartners.com/publicsector/contracts/supplier-contracts/tapco>

[Click Here to Visit TAPCO and OMNIA Partners Page](#)

TAPCO OMNIA Partners Contract Facts & Benefits

<p>Master agreement is held by a lead public agency with OMNIA Partners.</p>	→	<p>OMNIA Partners program meets state statutes for both the competitive solicitation and public agency consent.</p>
<p>Master agreement is competitively solicited and open solicitations are advertised in national publications.</p>	→	<p>Nothing precludes vendors from bidding on a OMNIA Partners’ program contract.</p>
<p>Master agreement is awarded by the soliciting public agency with the support of other advisory board members.</p>	→	<p>Advisory board oversight ensures master agreement is compliance with regional and national requirements and the solicitations remain transparent and objective.</p>
<p>OMNIA Partners is the only cooperative purchasing program founded and sponsored by NACo, NLC, ASBO and USCM.</p>	→	<p>These four national public organizations offer support for the program and recognize the value of the most favorable public agency pricing on high-quality products and services.</p>
<p>TAPCO’s master agreement was nationally solicited and competitively awarded by Barron County, WI based on respondents to the public solicitation.</p>	→	<p>The number, variety and quality of respondents affirms the solicitation package was unbiased and comprehensive.</p>
<p>The master agreement was awarded based on TAPCO being the lowest bidder on three pricing scenarios.</p>	→	<p>The master agreement ensures compliance with state procurement requirements to best overall supplier government pricing.</p>
<p>TAPCO provides traffic control products and related products and solutions.</p>	→	<p>TAPCO saves the public agency time, resources, and money at every step while providing one point of contact for the entire project.</p>

TAPCO Products & Solutions for State, Local and Educational Organizations

Intelligent Warning Systems

- Radar Driver Feedback Signs
- BlinkerBeacon™
- BlinkerSign®
- Rectangular Rapid Flashing Beacon

Parking & ITS Solutions

- Prefabricated Shelters
- Network, Traffic Management
- Hydraulic Slide and Swing Gate Operators
- Phone Entry Systems and Access Keypads
- Parking Gate Operators and Accessories
- Valet Stations
- Cloud-based Parking Management
- Clearance Tubes and Gate Arm Guards
- Traffic Spike Systems
- Message Display Boards
- Solar Cellular Communication

Industrial Products

- Industrial Sweepers
- Barricades
- Standard Guardrail
- Dock Bumpers and Lights
- Wheel Chocks and Cable Protectors
- Structural Protectors and Guards
- Warning Whips and Accessories
- Location Marking and Floor Signage
- Portable Work Lights
- Mats and Mirrors
- Emergency Washing Stations

Work Zone Products & Safety Apparel

- High Visibility Vest and Apparel
- Eye and Ear Protection, First Aid
- Emergency Response Gear
- Cones and Barrier Webbing
- Flags and Barricade Tape
- Channelizers and Barricades
- Cushions, Barriers and Attenuators
- Roll-up/Rigid Sign Stands and Signs
- Traffic Paddles
- LED Light Bars and Beacons
- Message, Radar Feedback Boards

Delineators, Traffic Items and Markers

- Surface Mount and Portable Delineators
- Modular Delineator and Sign Systems
- Ground Mount Delineators and Drivers
- Hydrants
- Vehicle Stops, Parking Barriers and Posts
- Snow and Utility Markers
- Speed Humps, Tables, and Bumps
- Bollards and Bollard Covers
- Reflective and Pavement Markings
- Pavement , Chalk and Aerosol Stripers
- Pavement and Turf Paint

Signs & Digital Signmaking Products

- MUTCD, Federal and Government Signs
- Retail Signage
- Street Name Signs
- Sign Hardware and Blanks
- Reflective Sheeting and Tape
- Films and Overlays
- Sign Making Accessories
- Retroreflectometers
- Sign Design Software
- Cutting Plotters and Imaging Scanners
- Silkscreening Equipment

Post, Poles, and Anchors

- Posts and Poles
- V-Loc® Breakaway Post Anchors
- Pole/Post Packages
- Decorative Post Coverings
- Pole/Post Bases

Streetscape, Parks and Recreation

- Decorative Poles and Bases
- Custom Signs and Sign Frames
- Decorative Fencing and Mailboxes
- Recycled Park Benches and Tables
- Luminaires
- Receptacles
- Bicycle Parking Racks and Signage
- Drinking Fountains
- Information Displays
- Flags



Pedestrian Crosswalk System: Rectangular Rapid-Flashing Beacon



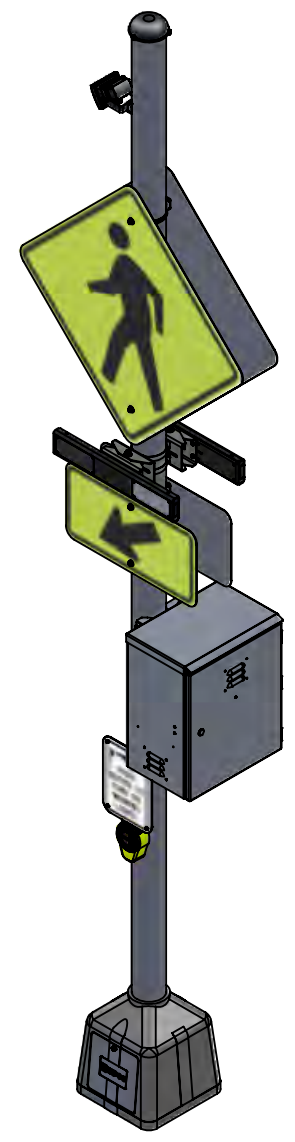
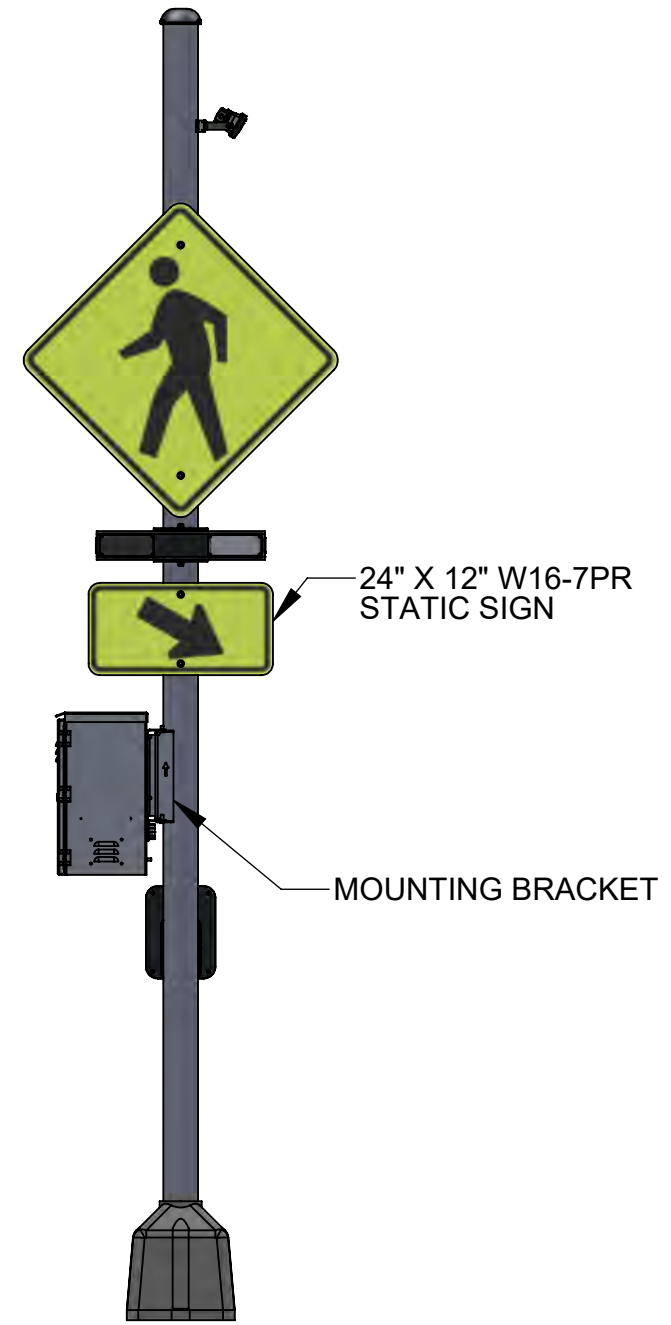
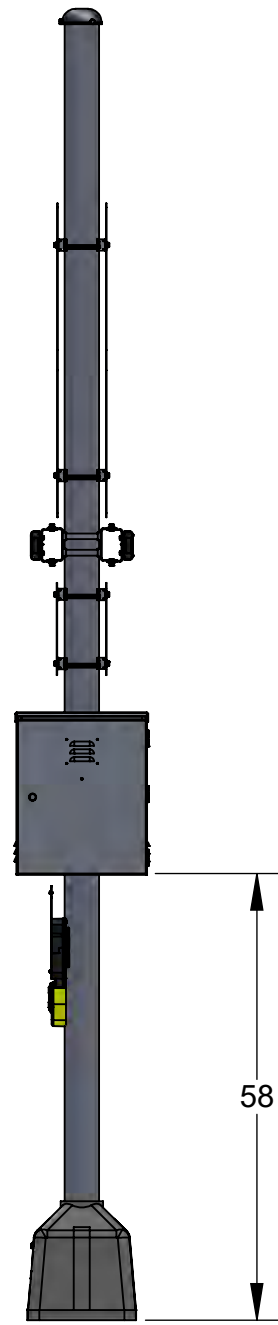
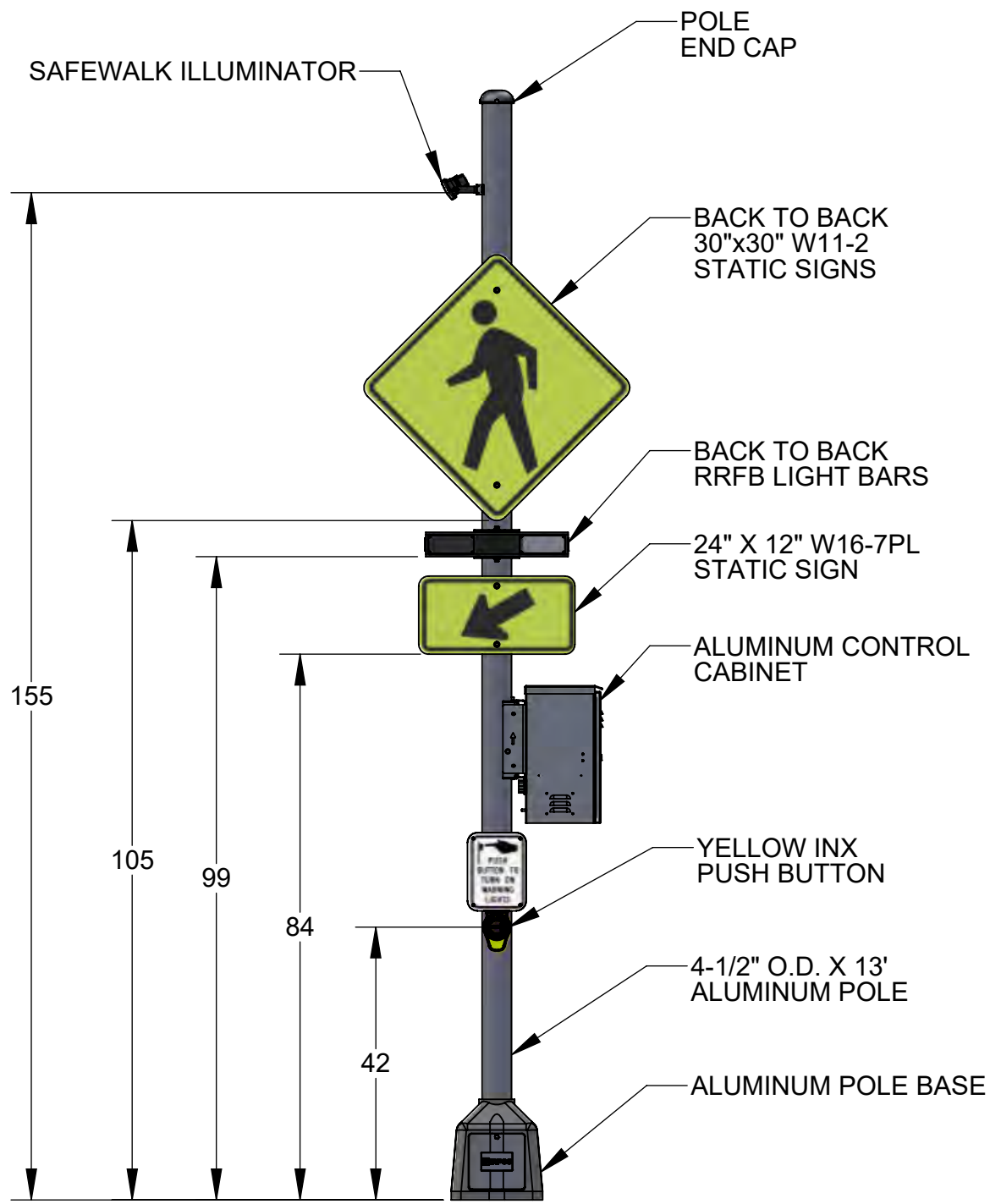

- NOTES:
1. CONTROL CABINET HEIGHT MAY VARY.
 2. WORM CLAMPS ARE PROVIDED, STANDARD 3/4" S/S BANDING IS RECOMMENDED
 3. J-BOLTS NOT SHOWN
 4. ALL DIMENSIONS ARE FOR REFERENCE ONLY.

REV.	DESCRIPTION	ECO	BY	DATE
A	INITIAL RELEASE	-	JP	03/08/2023

DIMENSIONS ARE INCH AND TOLERANCES ARE AS FOLLOWS UNLESS OTHERWISE SPECIFIED

.X	±0.1
.XX	±0.02
.XXX	±0.008
ANGLES	±1°

DESIGNED BY	DD	DATE	03/08/2023
DRAWN BY	DD	DATE	03/08/2023
APPROVED BY	JP	DATE	03/08/2023

TAPCO
TRAFFIC & PARKING CONTROL CO., INC.

5100 West Brown Deer Rd
Brown Deer, WI 53223 USA

7840 North 86th Street
Milwaukee, WI 53224 USA

TITLE: AC B2B RRFB ILLUMINATOR PED XING 13' POLE ARRANGEMENT

SIZE	DOCUMENT NO.	REVISION
B	(SEE TABLE FOR P/N) SD0951	A

SCALE: 1:25 REFERENCE: Q23001293 SHT 1 of 1

THIS DRAWING IS THE PROPERTY OF TAPCO (Traffic & Parking Control Company, INC.) AND SHALL NOT BE DUPLICATED WITHOUT PERMISSION

IWS CONTROLLER

SPECIFICATIONS

POWER	6V and 12VDC with power indicator light
INPUTS	2 digital inputs
OUTPUTS	2x two-channel (able to drive two warnings per output)
PROGRAMMABILITY	Locally using serial input (RS232) or remotely using BlinkLink® via cell modem
PROGRAM ACTIVATION OPTIONS	24/7, Dusk 'til Dawn, BlinkLink® Scheduling, Time Clock, Custom Input
LED-WARNING CONTROL COMPATIBILITY	BlinkerSign®, BlinkerBeacon™, RRFB-XL2™
DIMMABILITY	Auto-adjustable via solar panel (6V systems) Auto-adjustable via photocell sensor (12V systems)
INTERNAL SYSTEM CLOCK	Integrated with on-board battery backup
SELF-DIAGNOSTIC CAPABILITY	Internal temperature monitor
DAYLIGHT SAVING TIME	User programmable
OPERATING TEMPERATURE RANGE	-40°F to 176°F (-40°C to 80°C)
ENCLOSURE	IP67 rated
ENCLOSURE DIMENSIONS	3.2"W x 3.7"H x 2.5"D



1-phase Type 2 Surge Protector DS240 series



CITEL

**Imax
40 kA**



DS240-400

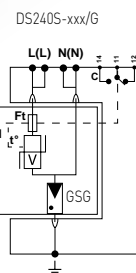
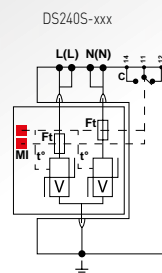
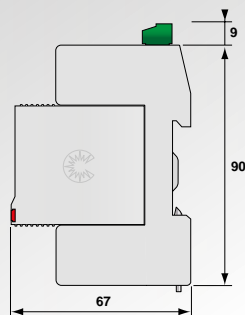

V : High energy varistor
Ft : Thermal fuse
MI: Remote signaling contact
t° : Thermal disconnection system
GSG : Specific gas tube
MI : Disconnection indicator

- Compact single-phase Type 2
- In : 20 kA
- Imax : 40 kA
- Common/Differential mode
- Pluggable module
- Remote signaling contact (option)
- Complies with EN 61643-11 and IEC 61643-11
- UL1449 ed.4

DS240 S-xxx/G

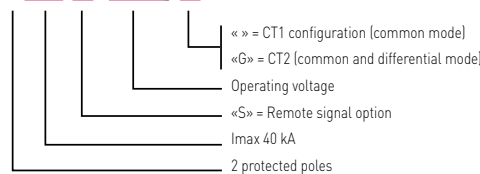

Characteristics

CITEL Model	DS240-400	DS240-230	DS240-230/G	DS240-120	DS240-120/G
Description	Compact 1-phase Type 2 Surge Protector - 230 V - Pluggable			Compact 1-phase Type 2 Surge Protector - 120 V - Pluggable	
Network	230 V single phase	230 V single phase	230 V single phase	120 V single phase	120 V single phase
Connection mode	L/PE and N/PE	L/PE and N/PE	L/N and N/PE	L/PE and N/PE	L/N and N/PE
AC system	IT	TN	TT-TN	TN	TT-TN
Max. AC operating voltage	Uc 440 Vac	255 Vac	255 Vac	150 Vac	150 Vac
Temporary Over Voltage (TOV) Characteristics - 5 sec.	UT 580 Vac withstand	335 Vac withstand	335 Vac withstand	180 Vac withstand	180 Vac withstand
Temporary Over Voltage (TOV) Characteristics - 120 mn	UT 770 Vac disconnection	440 Vac disconnection	440 Vac disconnection	230 Vac disconnection	230 Vac disconnection
Temporary Over Voltage N/PE (TOV HT)	UT -	-	1200 V/300A/200 ms withstand	-	1200 V/300A/200 ms withstand
Residual current - Leakage current at Uc	Ipe < 1 mA	< 1 mA	None	< 1 mA	None
Max. Load current (if connection serie)	IL 20 A	20 A	20 A	20 A	20 A
Follow current	If None	None	None	None	None
Nominal discharge current - 15 x 8/20 µs impulses	In 20 kA	20 kA	20 kA	20 kA	20 kA
Max. discharge current -max. withstand @ 8/20 µs by pole	Imax 40 kA	40 kA	40 kA	40 kA	40 kA
Protection level CM/DM @In (8/20µs) and @ 6kV (1.2/50µs)	Up 1.8 kV	1.25 kV	1.5/1.25 kV	0.9 kV	1.5/0.9 kV
Admissible short-circuit current	Iscrr 10000 A	10000 A	10000 A	10000 A	10000 A
Associated disconnectors					
Thermal disconnector	internal				
Fuses	Fuses Type gG - 50 A*				
Installation ground fault breaker	Type "S" or delayed				
Mechanical characteristics					
Dimensions	see diagram				
Connection to Network	by screw terminals: 1.5-10mm ² (L/N) or 2.5-25mm ² (PE)				
Disconnection indicator	2 mechanical indicators	2 mechanical indicators	1 mechanical indicator	2 mechanical indicators	1 mechanical indicator
Remote signaling of disconnection	Option DS240S-400 : output on changeover contact	Option DS240S-230 : output on changeover contact	Option DS240S-230/G : output on changeover contact	Option DS240S-120 : output on changeover contact	Option DS240S-120/G : output on changeover contact
Spare unit	DSM240-400	DSM240-230	DSM240-230/G	DSM240-120	DSM240-120/G
Mounting	Symmetrical rail 35 mm (EN60715)				
Operating temperature	-40/+85°C				
Protection rating	IP20				
Housing material	Thermoplastic UL94-V0				
Standards compliance	IEC 61643-11 / EN 61643-11 / UL1449 ed.4/EN 50539-11				
Certification	UL / CSA /EAC	UL / CSA /EAC	UL / CSA /EAC / TUV SUD	UL / CSA /EAC	UL / CSA /EAC
Part number	311401	311701	311721	311601	311621

*Note: Rating in compliance with NF C15-100 art. 534.1.5.3. An order to increase service continuity, higher rating can be used. For further information, please consult product instructions.

**Note: CM = Common mode (L/PE or N/PE)/ DM = Differential mode (L/N)





- Features :
 - Universal AC input/Full range
 - Protections: Short circuit / Overload / Over voltage
 - Cooling by free air convection
 - Can be installed on DIN rail TS-35/7.5 or 15
 - Class I, Div 2 Hazardous Locations T4
 - LED indicator for power on
 - DC OK relay contact
 - No load power consumption<0.75W
 - 100% full load burn-in test
 - 3 years warranty



SPECIFICATION

MODEL	MDR-60-5	MDR-60-12	MDR-60-24	MDR-60-48	
OUTPUT	DC VOLTAGE	5V	12V	24V	48V
	RATED CURRENT	10A	5A	2.5A	1.25A
	CURRENT RANGE	0 ~ 10A	0 ~ 5A	0 ~ 2.5A	0 ~ 1.25A
	RATED POWER	50W	60W	60W	60W
	RIPPLE & NOISE (max.) Note.2	80mVp-p	120mVp-p	150mVp-p	200mVp-p
	VOLTAGE ADJ. RANGE	5 ~ 6V	12 ~ 15V	24 ~ 30V	48 ~ 56V
	VOLTAGE TOLERANCE Note.3	±2.0%	±1.0%	±1.0%	±1.0%
	LINE REGULATION	±1.0%	±1.0%	±1.0%	±1.0%
	LOAD REGULATION	±1.5%	±1.0%	±1.0%	±1.0%
	SETUP, RISE TIME Note.5	500ms, 30ms/230VAC 500ms, 30ms/115VAC at full load			
HOLD UP TIME (Typ.)	50ms/230VAC 20ms/115VAC at full load				
INPUT	VOLTAGE RANGE	85 ~ 264VAC 120 ~ 370VDC			
	FREQUENCY RANGE	47 ~ 63Hz			
	EFFICIENCY (Typ.)	78%	86%	88%	87%
	AC CURRENT (Typ.)	1.8A/115VAC 1A/230VAC			
	INRUSH CURRENT (Typ.)	COLD START 30A/115VAC 60A/230VAC			
	LEAKAGE CURRENT	<1mA / 240VAC			
PROTECTION	OVERLOAD	105 ~ 150% rated output power Protection type : Constant current limiting, recovers automatically after fault condition is removed			
	OVER VOLTAGE	6.25 ~ 7.25V	15.6 ~ 18V	31.2 ~ 36V	57.6 ~ 64.8V
		Protection type : Shut down o/p voltage, re-power on to recover			
FUNCTION	DC OK SIGNAL	Relay contact rating(max.): 30V/1A resistive			
ENVIRONMENT	WORKING TEMP.	-20 ~ +70°C (Refer to "Derating Curve")			
	WORKING HUMIDITY	20 ~ 90% RH non-condensing			
	STORAGE TEMP., HUMIDITY	-40 ~ +85°C, 10 ~ 95% RH			
	TEMP. COEFFICIENT	±0.03%/°C (0 ~ 50°C)			
	VIBRATION	Component : 10 ~ 500Hz, 2G 10min./1cycle, period for 60min. each along X, Y, Z axes ; Mounting : Compliance to IEC60068-2-6			
SAFETY & EMC (Note 4)	SAFETY STANDARDS	UL508, UL60950-1, TUV EN60950-1, Class I, Div. 2 Group A, B, C, D Hazardous Locations T4 approved			
	WITHSTAND VOLTAGE	I/P-O/P:3KVAC I/P-FG:2KVAC O/P-FG:0.5KVAC			
	ISOLATION RESISTANCE	I/P-O/P, I/P-FG, O/P-FG:>100M Ohms / 500VDC / 25°C / 70% RH			
	EMC EMISSION	Compliance to EN55011, EN55022 (CISPR22), EN61204-3 Class B, EN61000-3-2,-3			
	EMC IMMUNITY	Compliance to EN61000-4-2, 3, 4, 5, 6, 8, 11, EN55024, EN61000-6-2, EN61204-3, heavy industry level, criteria A			
OTHERS	MTBF	299.2K hrs min. MIL-HDBK-217F (25°C)			
	DIMENSION	40*90*100mm (W*H*D)			
	PACKING	0.33Kg; 42pcs/14.8Kg/0.82CUFT			
NOTE	1. All parameters NOT specially mentioned are measured at 230VAC input, rated load and 25°C of ambient temperature. 2. Ripple & noise are measured at 20MHz of bandwidth by using a 12" twisted pair-wire terminated with a 0.1uf & 47uf parallel capacitor. 3. Tolerance : includes set up tolerance, line regulation and load regulation. 4. The power supply is considered a component which will be installed into a final equipment. The final equipment must be re-confirmed that it still meets EMC directives. For guidance on how to perform these EMC tests, please refer to "EMI testing of component power supplies." (as available on http://www.meanwell.com) 5. Length of set up time is measured at first cold start. Turning ON/OFF the power supply may lead to increase of the set up time.				

Case No.962A Unit:mm

Mechanical Specification

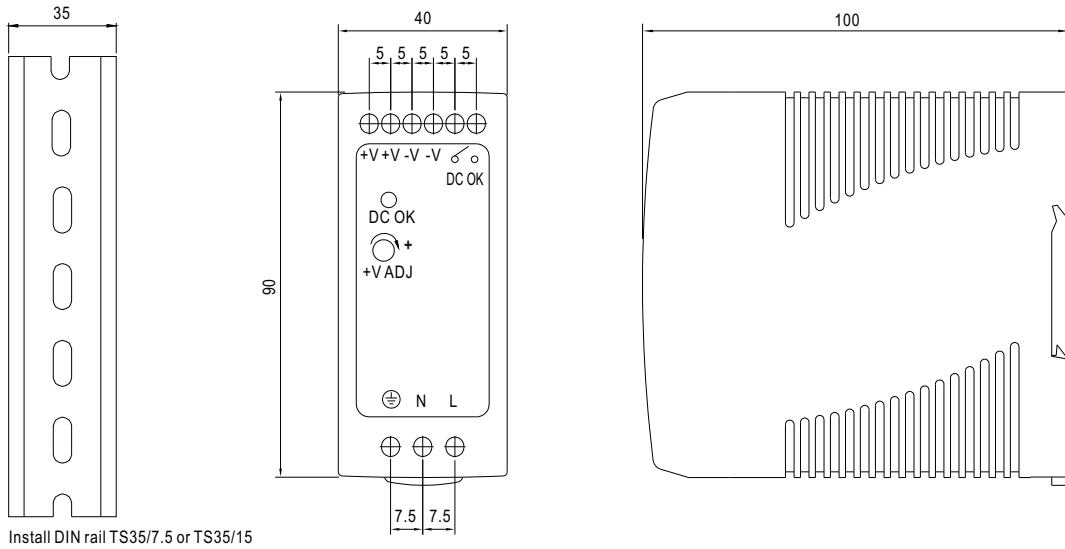

Block Diagram

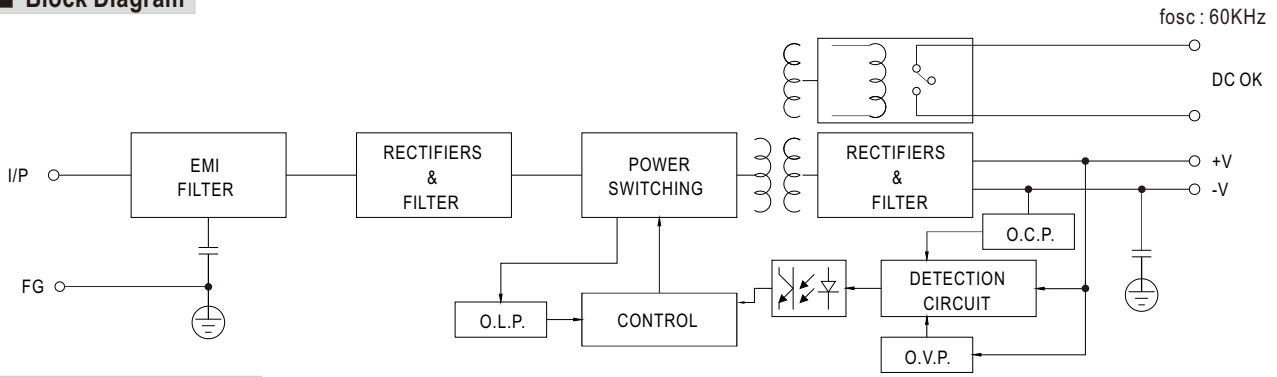

DC OK Relay Contact

Contact Close	PSU turns on / DC OK.
Contact Open	PSU turns off / DC Fail.
Contact Ratings (max.)	30V/1A resistive load.

Derating Curve

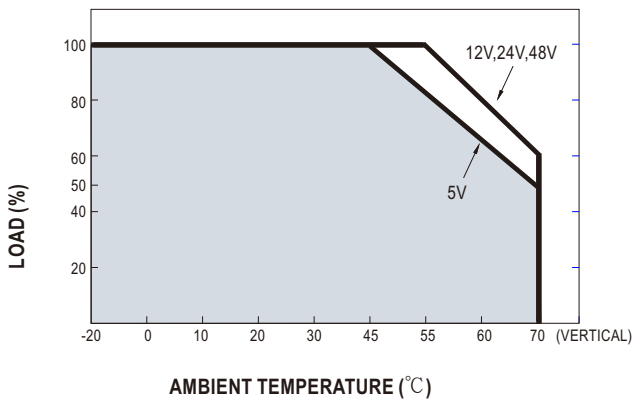

Output Derating VS Input Voltage

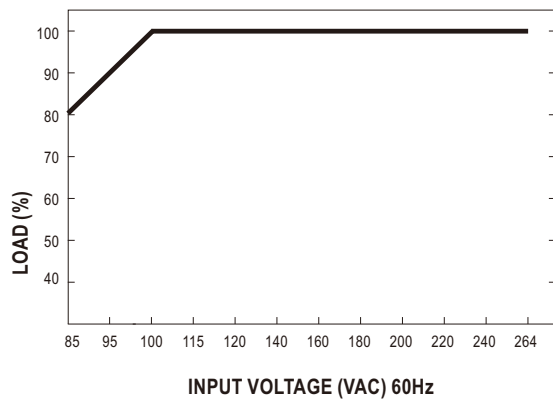

Mouser Electronics

Authorized Distributor

Click to View Pricing, Inventory, Delivery & Lifecycle Information:

[Mean Well:](#)

[MDR-60-12](#) [MDR-60-48](#) [MDR-60-24](#) [MDR-60-5](#)

LARGE CABINET & MOUNTING BRACKETS

CABINET SPECIFICATIONS

CERTIFICATION	NEMA 3R type
MATERIAL	0.125" aluminum
MOUNTING OPTIONS	6 stainless steel studs for various mounting bracket options including banding, U-bolt, wall-mount, square pole and wood post.
HINGES	3 tamper-resistant stainless steel hinges
ACCESS	Replaceable #2 traffic lock with keys
VENTING	Screened vents on cabinet side and door
DRAINAGE	Screened drain holes on bottom of cabinet
UV RESISTANT LABEL	Applied to exterior of cabinet outlining model number, serial number, date of manufacture as well as any applicable regulatory information
CONTROL PANEL	All circuit components are attached or connected to removable control panel for maintenance
DOOR MOUNTED POUCH	Contains system documents
ENCLOSURE DIMENSIONS	17.5"W x 21.1"H x 11.6"D



FRONT



BACK

ROUND POLE BANDING BRACKET

MATERIAL	Aluminum
POLE TYPE	2 $\frac{3}{8}$ " and larger round poles
HARDWARE TO MOUNT TO CABINET	Stainless steel hardware provided
HARDWARE TO MOUNT TO POLE	Customer supplied banding up to $\frac{3}{4}$ " width. Worm drive clamp provided to assist with install.
BRACKET QUANTITY PER CABINET	3
DIMENSIONS	6.8"W x 3.7"H x 1.1"D

SQUARE POLE BOLT-THROUGH BRACKET

MATERIAL	Aluminum
POLE TYPE	2" to 6" square poles
HARDWARE TO MOUNT TO CABINET	Stainless steel hardware provided
HARDWARE TO MOUNT TO POLE	Stainless steel hardware provided specific to pole size
BRACKET QUANTITY PER CABINET	3
DIMENSIONS	Bolt length dependent upon pole size

MULTI-PURPOSE BRACKET

MATERIAL	Aluminum
POLE TYPE	2 $\frac{3}{8}$ " - 4 $\frac{1}{2}$ " round pole, square wood post or wall mount
HARDWARE TO MOUNT TO CABINET	Stainless steel hardware provided
HARDWARE TO MOUNT TO POLE	Customer supplied hardware for wall mounting. Stainless steel U-bolts provided for round pole mount. Lag bolts provided for square wood post mount.
BRACKET QUANTITY PER CABINET	2
DIMENSIONS	7"W x 7.2"H x 0.7"D



ROUND POLE BANDING BRACKET



SQUARE POLE BOLT-THROUGH BRACKET



MULTI-PURPOSE BRACKET



(800) 236-0112

TAPCOnet.com

UNIVERSAL SIDE-OF-POLE CABINET MOUNTING BRACKET

UNIVERSAL MOUNTING BRACKET

MATERIAL	5052-H32 Aluminum
MOUNTING HARDWARE INCLUDED	U-bolts and Straight Bolts, 3/8-16" (2) 3.5"L, (1) 4.5x6, (1), 4x5.5, (1) 3.5x4.5, (1) 2.375x3.5 (HK01AA)
MOUNTING METHODS ACCEPTED	Through bolts, u-bolts, banding
ACCEPTED POLE TYPES	2-3/8", 3", 3-1/2", 4", 4-1/2" Round, 2" Square Perforated Post
COMPATIBLE CABINETS	Small: 108766-PEM Medium: 108045-PEM (shown) Large: 120652-PEM
HUB EXTENSION	Threaded Pipe Extension (2), 3/4" x 2.5" SCH 40 Aluminum and 1-1/4" x 2.5" SCH 40 Aluminum
BRACKET TO CABINET HARDWARE	Nut, serrated flange, 5/16-18 SS
SECURITY HARDWARE	Tamper Resistant Screw, 1/4-20X0.75, BH Torx
SECURITY HARDWARE TOOL	Torx Driver, T-27 Pin Head, 1/4" Hex Driver
WEIGHT	7 lbs.
DIMENSIONS	12.54"Lx8.14"Wx3.5"D



FRONT - OPEN



FRONT - CLOSED



BACK - CLOSED

RECTANGULAR RAPID FLASHING BEACON: RRFB-XL2™

SPECIFICATIONS

POWER	Low voltage, current controlled from TAPCO controller
DIMMING	Variable based on photocell sensor input or 6V solar panel
LIGHT BAR HOUSING	Black powder-coated aluminum
VEHICLE LED MODULES	7"W x 3"H; 2 arrays of 8 amber LEDs spaced 7" apart, SAE J595 Class 1 Certified
PEDESTRIAN LED MODULES	0.5"W x 1.75"H side-viewable, flash simultaneously with vehicle LED (optional, one or both sides)
LED COLOR	Amber
FLASH PATTERNS	Interim Approval 21 compliant Wig-Wag plus Simultaneous (WW + S)
VISIBILITY	Daytime: more than 1,000 feet Nighttime: more than 1 mile
UNIVERSAL MOUNTING BRACKET	Articulates up to 30° Mounts to most common size metal or wood posts
MOUNTING HARDWARE	Banding to round pole, U-bolt to round pole, bolt to square pole
LIFE EXPECTANCY	100,000 hours
OPERATING TEMPERATURE RANGE	-40°F to 122°F (-40°C to 50°C)
LIGHT BAR DIMENSIONS	22"W x 4"H x 1.5"D



SIDE



TOP



8 7 6 5 4 3 2 1

REVISIONS				
REV.	DESCRIPTION	DATE	ECN #	AUTHOR/APPROVED
A	RELEASED FOR SUBMITTAL	5/2/2018	N/A	A.K./J.P.

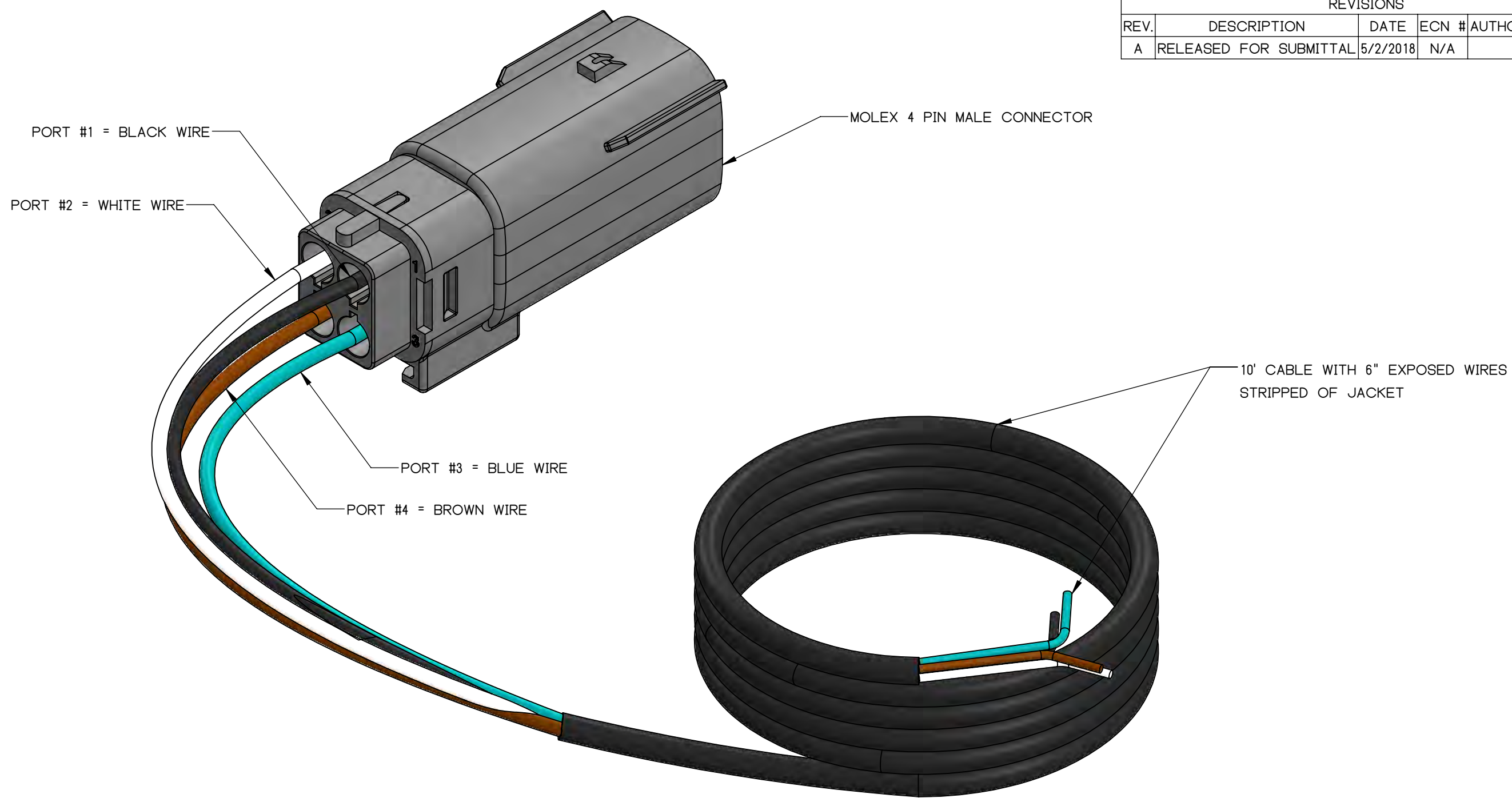

<small>ENGINEERING SPECIFICATIONS 136760</small>		
MATERIAL	MATERIAL <NOT SPECIFIED>	INTERPRET GEOMETRIC TOLERANCING PER: ASME Y14.5-2009
FINISH		REFERENCE: Q1802295

TOLERANCE UNLESS OTHERWISE SPECIFIED		TITLE: WIRE HARNESS, RRFB, 10' OF 4C W/MOLEX CONNECTOR			
HOLE ϕ	$\pm .003$	DESIGNED BY:		SIZE	DWG. NO.
DEC.	INCH	DRAWN BY:	A. KAVANAUGH	B	136760
X	$\pm .030$	CHECKED BY:	J. PATTERSON		
XX	$\pm .015$			REV	WEIGHT:
XXX	$\pm .005$			A	SCALE: 2:1
ANGULAR	$\pm 0.5^\circ$				SHEET 1 OF 1

PROPRIETARY AND CONFIDENTIAL THE INFORMATION CONTAINED IN THIS DRAWING IS THE SOLE PROPERTY OF TAPCO. ANY REPRODUCTION IN PART OR AS A WHOLE WITHOUT THE WRITTEN PERMISSION OF TAPCO IS PROHIBITED.

8 7 6 5 4 3 2 1

Polara iNX Push button

SPECIFICATIONS

POWER	10 to 24VDC
PUSH BUTTON	ADA compliant. Field adjustable directional arrow is standard; bidirectional and blank buttons available. Optional adjustable locator tone
ACTIVATION CONFIRMATION	Yellow LEDs and voice confirmation activated when push button is pressed; custom message available
PUSH BUTTON HOUSING	Yellow powder coat finish is standard; black and green available
SPEAKER	Field replaceable, weather resistant, 10-watt audio amplifier Maximum volume: 100 dB at 1 meter
INSTRUCTIONAL SIGN	9" x 12" is standard; larger signs available; braille available. Retroreflective sheeting with tamper-resistant mounting screws
OPERATING FORCE	Three adjustable settings: .5 to 3.5 pounds
IDLE CURRENT DRAW	~9mA @ 12 VDC
PEAK CURRENT DRAW	~500mA (@15VDC) with voice message at maximum
ENCLOSURE	NEMA 250 Type 4X Powdercoated cast aluminum cover and backplate
CONNECTIVITY	Bluetooth 5.0 Polara Field Service app for customization
WIRING	6 conductor
OPERATING TEMPERATURE RANGE	-30°F to 165°F (-34°C to 74°C)
DIMENSIONS	9"W x 18.2"L x 2.6"H



SAFEWALK™ CROSSWALK ILLUMINATOR

FEATURES AND BENEFITS

Increase pedestrian visibility at poorly lit, two-lane crossings with the SafeWalk™ Crosswalk Illuminator – a simple safety enhancement to TAPCO Pedestrian Crosswalk Systems.

- Flood light illuminates the approach area of the crosswalk
- Beam light projects outward, illuminating the middle of the crosswalk
- Activates concurrently with LED-enhanced warning alerts
- Adjustable brackets allow for precise light focus at most crossings
- Rugged enclosure to withstand weather and surrounding environment

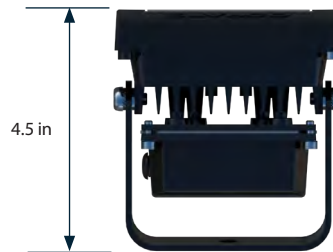

Bottom View

SPECIFICATIONS

POWER INPUT	12VDC
POWER CONSUMPTION	700mA to 1.4A
LIGHT DISTANCE	6 by 15 feet per illuminator
INSTALLATION HEIGHT	12 to 15 feet
HOUSING	Aluminum and weather resistant polycarbonate
OPERATING TEMPERATURE RANGE	-40°F to 176°F (-40°C to 80°C)



SYSTEM CAPABILITIES

COMPATIBILITY	RRFB, Blinkersign® and BinkerBeacon™ Pedestrian Crosswalk Systems
LIGHT VITALITY	2 LEDs engineered to light up a crosswalk
LIGHT DURATION	Varies based on preprogrammed settings - works in conjunction with warning alerts
WIND LOAD RATING	Up to 120 mph*

*Dependent upon pole size and system arrangement



(800) 236-0112

TAPCOnet.com



1.875"R

W11-2

30 in

30 in

30" Diamond, 1.875" Rad
w/(2) 3/8" holes 30" apart on center
Sheeting: DG3 Fluor. Yellow-green

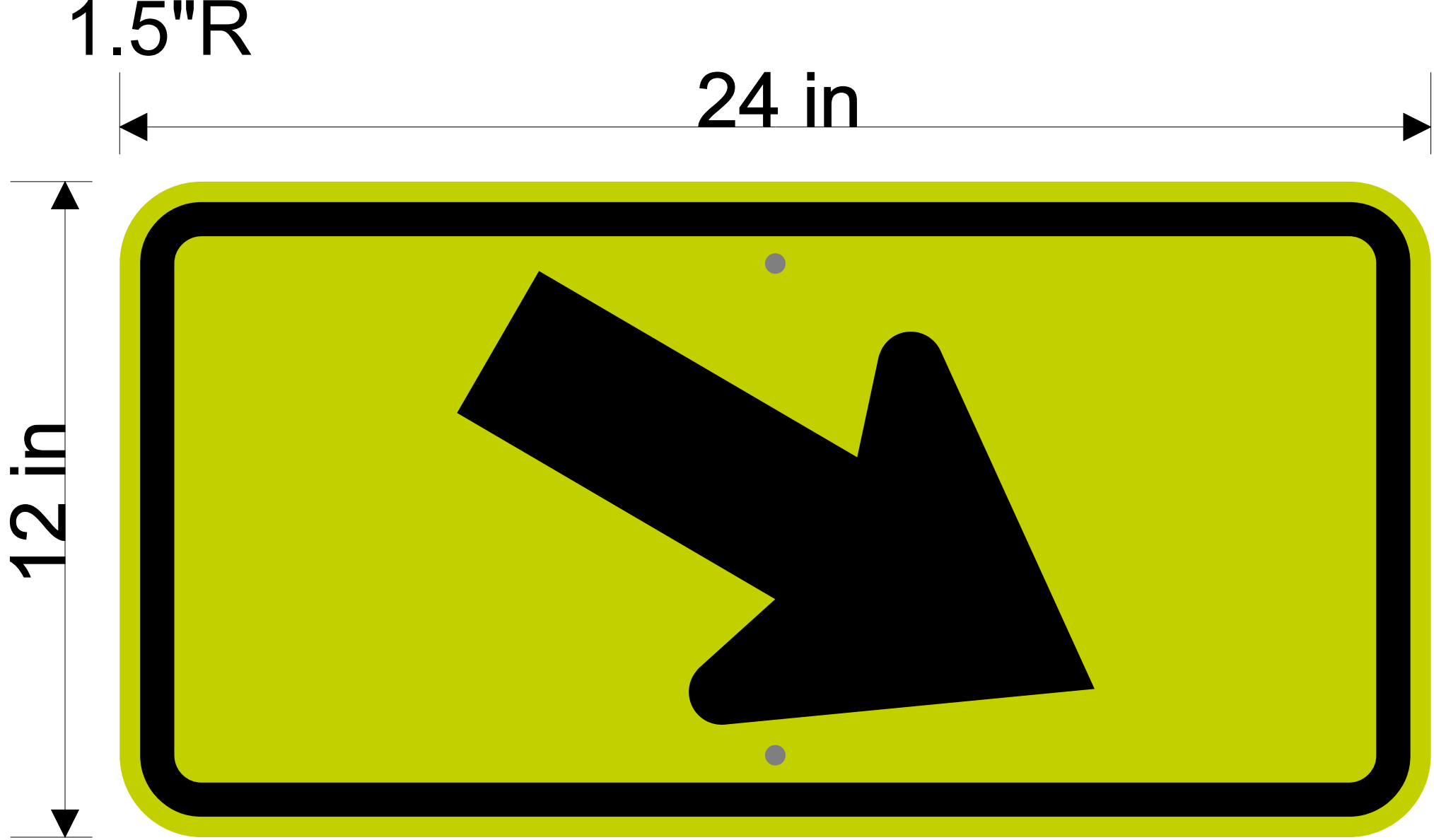

24"x12" .080 gauge, 1.5" Rad
w/(2) 3/8" holes 1.5" in
Sheeting: DG3 Fluor. Yellow-green

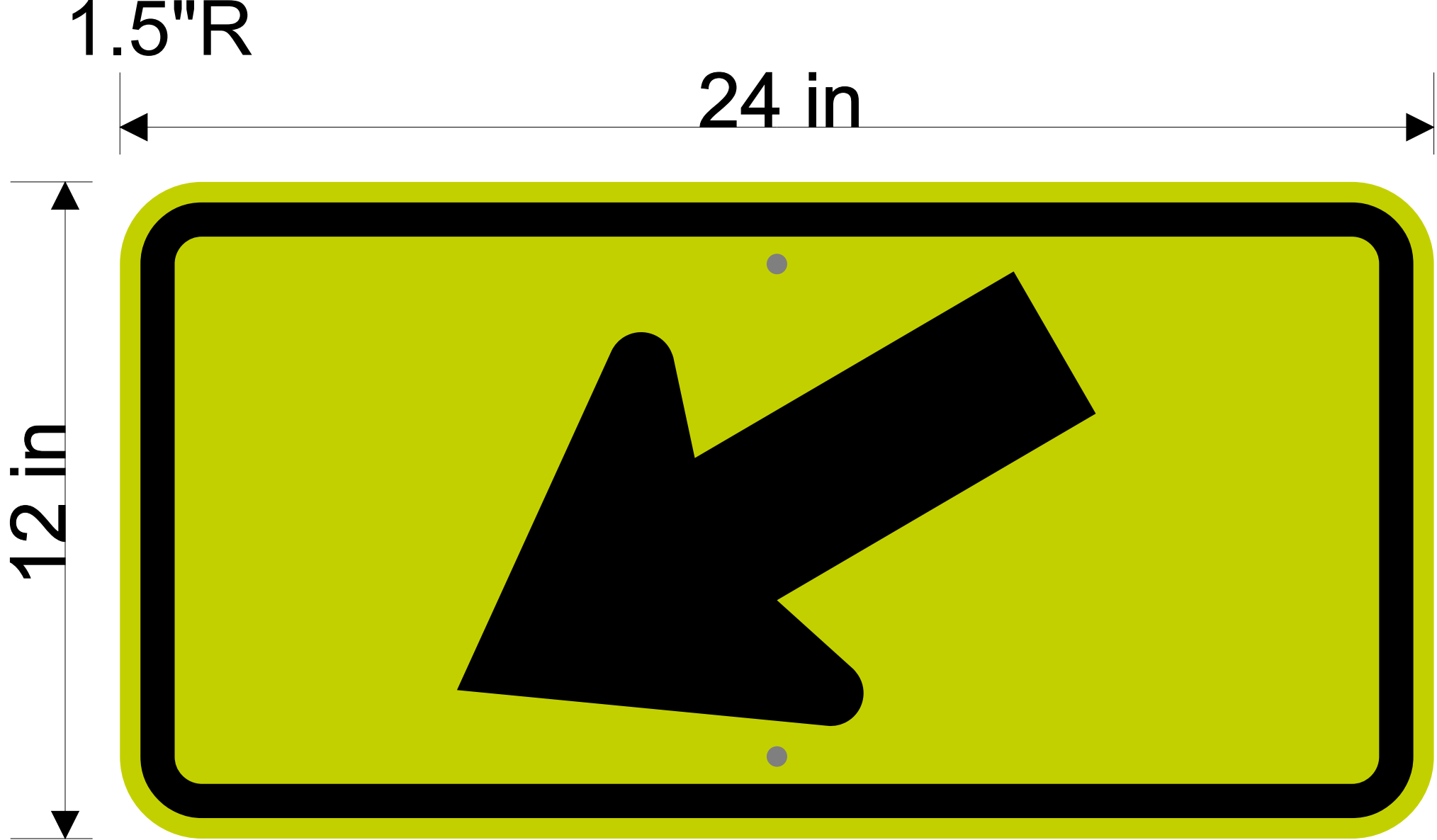

24"x12" .080 gauge, 1.5" Rad
w/(2) 3/8" holes 1.5" in
Sheeting: DG3 Fluor. Yellow-green

Pedestal Bases and Traffic Signal Standards

The TAPCO pedestal base is designed in accordance with the current AASHTO Specification for the Design and Construction of Structural Supports for Traffic Signals, Signs and Highway Light to withstand a 3 second gust wind speed of 90 miles per hour. These standards and tests for compliance were developed by the Wisconsin Department of Transportation.

Traffic Signal Standard

Pipes are cleaned of all mill scale, oil and foreign material. They are stocked unpainted, yet are able to be powder coated or anodized with color of your choice. They are made of Schedule 80 aluminum alloy 6061-T6 manufactured in accordance with ASTM B429. Pipe is threaded on one end. The outside dimensions are 4.5". Standard lengths are 3.5', 4', 8', 9', 10', 11', 13' and 15'.

Pedestal Base

The TP-358 series base is used for mounting traffic signals, flasher assemblies or traffic control equipment. The base assembly is arranged to mount on a concrete base, attached by four internal galvanized anchor bolts (standard is 1"x42"). The square cast aluminum base is made of aluminum alloy 319 in accordance with WISDOT specifications. It includes an 8.5" square handhole cover that is also made of aluminum alloy 319. The door is secured by a 5/16"-18x1" stainless hex head bolt. They are stocked unpainted, yet are able to be powder coated or anodized with color of your choice. The base is FHWA certified and meets AASHTO break away requirements.

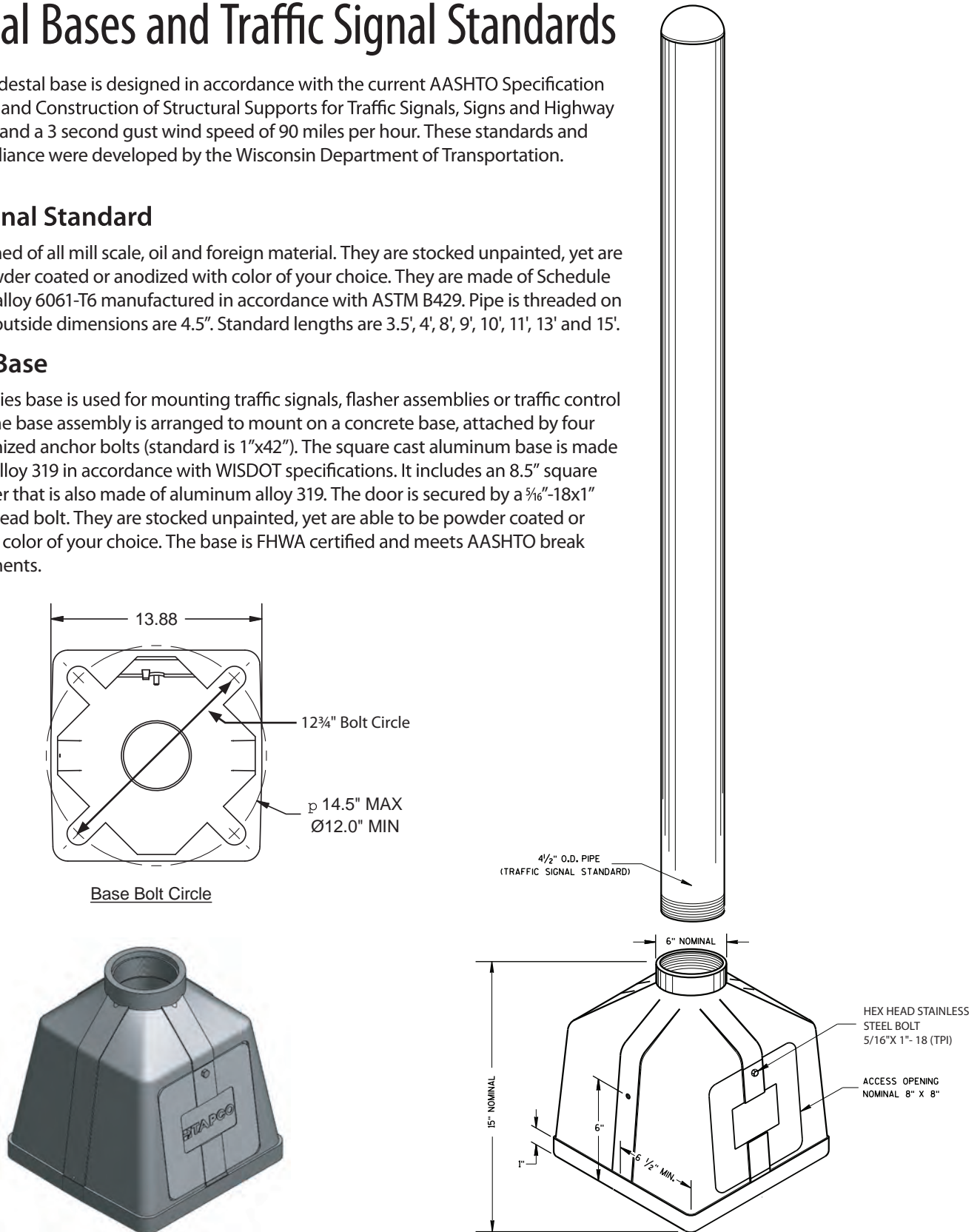

8 7 6 5 4 3 2 1

REVISIONS				
REV.	DESCRIPTION	DATE	CC #	AUTHOR/APPROVED
A	INITIAL RELEASE	-	-	--/--
B	SWITCHED 037-00016 TO 140153	6/17/2019	CC-120	C.G./J.R.P.
C	SWITCHED 140153 TO 037-00016	6/21/2019	CC-250	C.G./J.R.P.

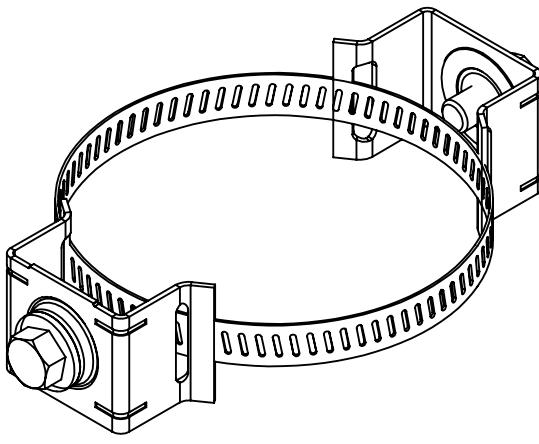
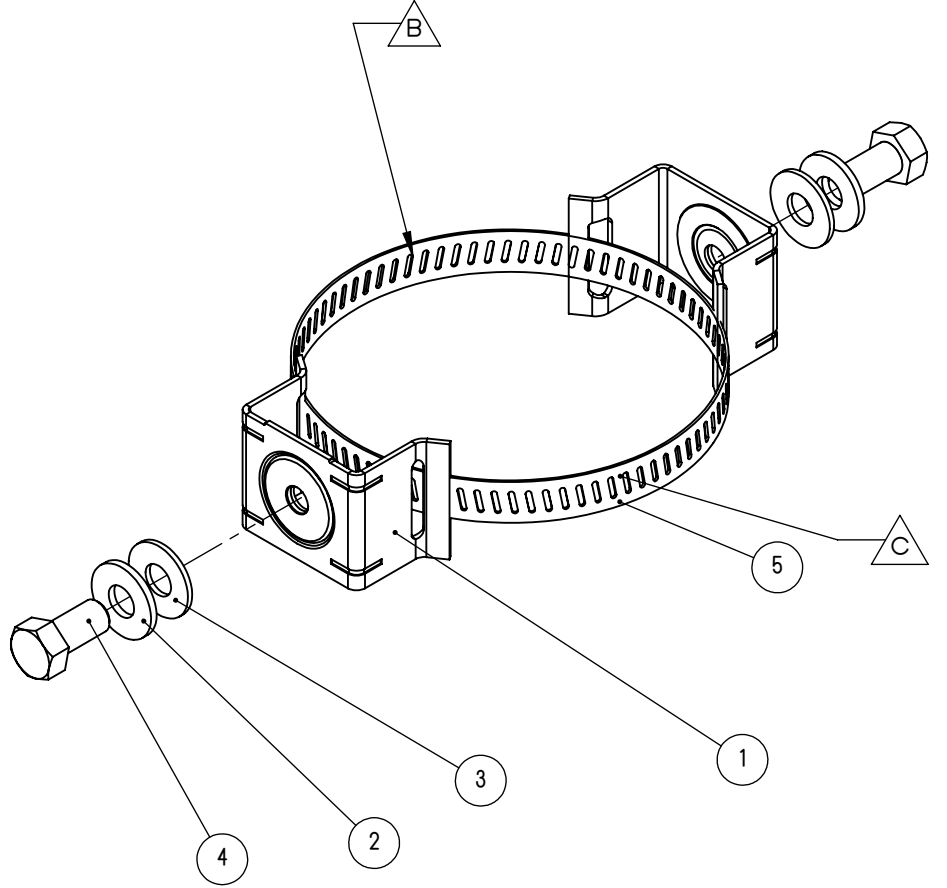

ITEM NO.	PART NUMBER	DESCRIPTION	DWG QTY.	KIT QTY	UNITS
6	126997 (NOT SHOWN)	BAG, RECLOSABLE 10"X12" 2 MIL S-1701	1	1	EA
5	037-00016	SNAP-LOK ASSY, WORM CLAMP 2 TO 12-1/4DIA X 9/16W	1	2	EA
4	763-00042	BOLT 3/8-16X3/4 HEX S/S	2	4	EA
3	052-00295	NYLON WASHER 5/16" X 7/8" OD	2	4	EA
2	052-00295	NYLON WASHER 5/16" X 7/8" OD	2	4	EA
1	035-00008	FLARED LEG BRACKET, NO BOLT, NO WASHER D02299	2	4	EA



MATERIAL	STAINLESS STEEL	INTERPRET GEOMETRIC TOLERANCING PER: ASME Y14.5-2009
FINISH	RAW	REFERENCE:

TOLERANCE UNLESS OTHERWISE SPECIFIED	
HOLE ϕ	$\pm .003$
DEC.	INCH
X	$\pm .030$
XX	$\pm .015$
XXX	$\pm .005$
ANGULAR	$\pm 0.5^\circ$

TITLE: SIGN MOUNTING KIT, BANDED, FLARE LEG, STANDARD, FOR MOUNTING B2B STATIC SIGNS TO A LARGE POLE					
DESIGNED BY:	TAPCO	SIZE	DWG. NO.	REV	WEIGHT:
DRAWN BY:	C. GRAVES	6/21/2019	B	107265	C
CHECKED BY:	J. PATTERSON	6/24/2019			SCALE: 1:2

PROPRIETARY AND CONFIDENTIAL THE INFORMATION CONTAINED IN THIS DRAWING IS THE SOLE PROPERTY OF TAPCO. ANY REPRODUCTION IN PART OR AS A WHOLE WITHOUT THE WRITTEN PERMISSION OF TAPCO IS PROHIBITED. SHEET 1 OF 1

8 7 6 5 4 3 2 1



RESOLUTION NO. _____

A RESOLUTION ACCEPTING A PROPOSAL FROM TAPCO FOR THE PURCHASE OF A PEDESTRIAN CROSSWALK SIGNALIZATION SYSTEM FOR A MID-BLOCK CROSSWALK APPLICATION AT CLARENDON HILLS ROAD AND ROGER ROAD IN AN AMOUNT NOT TO EXCEED \$11,779.02

BE IT RESOLVED BY THE CITY COUNCIL OF THE CITY OF DARIEN, DU PAGE COUNTY, ILLINOIS, as follows:

SECTION 1: The City Council of the City of Darien hereby accepts a proposal from TAPCO for the purchase of a Pedestrian Crosswalk Signalization System for a mid-block crosswalk application at Clarendon Hills Road and Roger Road in an amount not to exceed \$11,779.02, a copy of which is attached hereto as "**Exhibit A**".

SECTION 2: This Resolution shall be in full force and effect from and after its passage and approval as provided by law.

PASSED BY THE CITY COUNCIL OF THE CITY OF DARIEN, DU PAGE COUNTY, ILLINOIS, this 3rd day of April 2023.

AYES: _____

NAYS: _____

ABSENT: _____

APPROVED BY THE MAYOR OF THE CITY OF DARIEN, DU PAGE COUNTY, ILLINOIS, this 3rd day of April 2023.

JOSEPH MARCHESE, MAYOR

ATTEST:

JOANNE E. RAGONA, CITY CLERK

APPROVED AS TO FORM

CITY ATTORNEY



TAPCO

Safe travels.

SALES QUOTE

Traffic and Parking Control Co., Inc.
 5100 West Brown Deer Rd
 Brown Deer, WI 53223
 Phone No.:800-236-0112
 E-Mail: info@tapconet.com

SALES QUOTE DATE

3/9/2023

SALES QUOTE NUMBER

Q23001293

CUSTOMER NO.

C12455

Page: 1

BILL TO

City of Darien
 Dan Gombac
 Public Works Department
 1041 S. Frontage Road
 Darien, IL 60561
 United States of America

SHIP TO

City of Darien- Public Works
 Dan Gombac
 1041 S. Frontage Road
 Darien, IL 60561
 United States of America

SHIP VIA	TERMS	SALESPERSON	VALID UNTIL
BEST RATE	Net 30 DAYS	Deidre Jones	4/8/2023

Item/Description	U/M	Quantity	Unit Price	Total Price
2180-CUSTOM Controller, Dual Legacy, 120VAC, 120652, Hollow, Polara APS, SW, 6 Light Bars Max	Each	1	2,520.00	2,520.00
142048 Universal Cabinet Mounting Bracket, SOP Cabinets 108766, 108045, 120652, Includes U-Bolt Hardware	Each	1	157.46	157.46
138089 RRFB, Dimmable, Assembly with Universal Mounting Kit	Each	4	517.50	2,070.00
140259 Wire Harness, Dimmable RRFB, 50' of Cable w/ Male Connector	Each	2	110.66	221.32
143402 SafeWalk Illuminator Assembly with Mounting Kit	Each	2	261.00	522.00
144162 Push Button, iNX, No Braille, Yellow Single Arrow, 9"x12" R10-25 Faceplate	Each	2	675.00	1,350.00
146153-50 Cable, Bulk, 6C 18AWG, Outdoor/Burial Rated, ICEA E2 Color, 50 foot pre-cut length	Each	2	105.30	210.60
373-05075 W11-2,30"x30"x.080 DG3 FYG,Pedestrian Crossing (Symbol) Fed Spec - Fluorescent Yellow-Green Sign	Each	4	110.66	442.64
373-01757	Each	2	40.46	80.92

All prices are listed in US Dollar (USD)
 For terms and conditions, please visit <https://tapconet.com/terms-conditions>



SALES QUOTE

Traffic and Parking Control Co., Inc.
 5100 West Brown Deer Rd
 Brown Deer, WI 53223
 Phone No.:800-236-0112
 E-Mail: info@tapconet.com

SALES QUOTE DATE

3/9/2023

SALES QUOTE NUMBER

Q23001293

CUSTOMER NO.

C12455

Page: 2

BILL TO

City of Darien
 Dan Gombac
 Public Works Department
 1041 S. Frontage Road
 Darien, IL 60561
 United States of America

SHIP TO

City of Darien- Public Works
 Dan Gombac
 1041 S. Frontage Road
 Darien, IL 60561
 United States of America

SHIP VIA	TERMS	SALESPERSON	VALID UNTIL
BEST RATE	Net 30 DAYS	Deidre Jones	4/8/2023

Item/Description	U/M	Quantity	Unit Price	Total Price
W16-7PR,24"x12"x.080 DG3 FYG,Down Diagonal Right Arrow (Fed Spec) Sign				
373-01759	Each	2	40.46	80.92
W16-7PL,24"x12"x.080 DG3 FYG,Down Diagonal Left Arrow (Fed Spec) Sign				
373-13	Each	2	904.50	1,809.00
Standard Aluminum Pole, 13' Schedule 40 6061-T6 4.5" O.D. T.O.E.				
203-00014	Each	2	216.00	432.00
Base,Aluminum Square Pedestal, No Paint Door, SP-5444-PNC				
3177-00042	Each	8	40.46	323.68
J-Bolt,1"x 42"+4" ATSM F1554 GR-105 92k 12" Thread Full Galvanized with Nut & Lock Washer				
030-00006	Each	8	5.36	42.88
Washer Flat 1-1/16"ID x2.5OD"x.125" Galvanized For 1" A/B, for use w/item # 111644 (not incl)				
107265	Each	4	41.40	165.60
Sign Mounting Kit, Banded, Flared Leg, Standard For Mounting B2B Static Signs to a Large Pole				
IWS-ENGDSG	Days	2	400.00	800.00
Design Engineering Services				

Plus Shipping and Handling

Furnish only quote. Installation is not included.

All prices are listed in US Dollar (USD)
 For terms and conditions, please visit <https://tapconet.com/terms-conditions>



SALES QUOTE

Traffic and Parking Control Co., Inc.
 5100 West Brown Deer Rd
 Brown Deer, WI 53223
 Phone No.:800-236-0112
 E-Mail: info@tapconet.com

SALES QUOTE DATE

3/9/2023

SALES QUOTE NUMBER

Q23001293

CUSTOMER NO.

C12455

Page: 3

BILL TO

City of Darien
 Dan Gombac
 Public Works Department
 1041 S. Frontage Road
 Darien, IL 60561
 United States of America

SHIP TO

City of Darien- Public Works
 Dan Gombac
 1041 S. Frontage Road
 Darien, IL 60561
 United States of America

SHIP VIA	TERMS	SALESPERSON	VALID UNTIL
BEST RATE	Net 30 DAYS	Deidre Jones	4/8/2023

Item/Description	U/M	Quantity	Unit Price	Total Price
------------------	-----	----------	------------	-------------

TAPCO will make every effort to ship all systems in normal process; however, as a result of global supply chain constraints some components might be impacted by extended lead times.

Custom System and not returnable

Thank you! Deidre Jones
 Email: Deidre.jones@tapconet.com
 Phone: 262-649-5227

TAPCO OMNIA Partners Contract # 2020-200

Subtotal:	11229.02
Invoice Discount:	0.00
Total Sales Tax:	0.00
Total:	11,229.02

All prices are listed in US Dollar (USD)
 For terms and conditions, please visit <https://tapconet.com/terms-conditions>

AGENDA MEMO
Municipal Services Committee
March 27, 2023

ISSUE STATEMENT

A **resolution** accepting a proposal from Dorner Company for the City’s water system in an amount not to exceed \$54,935 to re-build internal critical components of pump control valves and altitude valves.

BACKGROUND/HISTORY

The proposed expenditure is for the maintenance of the City’s water variable speed water pumps. The pumps are independent inline components of the water system utilized to deliver potable water to maintain pressures. The pumps are further regulated by automated pump control valves that regulate the amount of water to satisfy pressures to the system and tanks. The additional 3 valves, referred to as altitude valves regulate the amount of water that is delivered to the 3 spheroid tanks throughout town.

The maintenance is considered preventive maintenance and consists of rebuilding the various valves and critical components. See attached sheet labeled as **Exhibit A** for additional rebuilding specifications.

The City requested competitive quotes for the rebuilding of the valves and received two responses.

VENDOR	LUMP SUM COST
Dorner Company	\$54,935
Omni Pump Repair	\$97,530
Metropolitan Pump	no quote

References for the proposed awarded vendor, Dorner Company, were verified with very good responses.

The budgeted expenditure would be expended from the following account:

ACCOUNT NUMBER	ACCOUNT DESCRIPTION	FY23-24	PROPOSED EXPENDITURE	PROPOSED BALANCE
02-50-4231	Maintenance Water System Cla Valve/Altitude Valves	\$50,000	\$54,935	(\$4,935) *

*The shortfall of the expense has been reviewed and the account will be in a position to absorb the shortfall.

STAFF RECOMMENDATION

Staff recommends accepting a proposal from Dorner Company for the City’s water system in an amount not to exceed \$54,935 to re-build internal critical components of pump control valves and altitude valves.

ALTERNATE DECISION

As recommended by the Committee.

DECISION MODE

This item will be placed on the April 3, 2023 City Council agenda for formal consideration.



RESOLUTION NO. _____

A RESOLUTION ACCEPTING A PROPOSAL FROM DORNER COMPANY FOR THE CITY’S WATER SYSTEM IN AN AMOUNT NOT TO EXCEED \$54,935 TO RE-BUILD INTERNAL CRITICAL COMPONENTS OF PUMP CONTROL VALVES AND ALTITUDE VALVES

BE IT RESOLVED BY THE CITY COUNCIL OF THE CITY OF DARIEN, DU PAGE COUNTY, ILLINOIS, as follows:

SECTION 1: The City Council of the City of Darien hereby accepts a proposal from Dorner Company for the City’s water system in an amount not to exceed \$54,935 to re-build internal critical components of pump control valves and altitude valves, a copy of which is attached hereto as **“Exhibit A”** and is by this reference expressly incorporated herein.

SECTION 2: This Resolution shall be in full force and effect from and after its passage and approval as provided by law.

PASSED BY THE CITY COUNCIL OF THE CITY OF DARIEN, DU PAGE COUNTY, ILLINOIS, this 3rd day of April 2023.

AYES: _____

NAYS: _____

ABSENT: _____

APPROVED BY THE MAYOR OF THE CITY OF DARIEN, DU PAGE COUNTY, ILLINOIS, this 3rd day of April 2023.

JOSEPH MARCHESE, MAYOR

ATTEST:

JOANNE E. RAGONA, CITY CLERK

APPROVED AS TO FORM:

CITY ATTORNEY

DORNER QUOTATION

To: Village of Darien
 Attn: Dennis Cable
 Ref: Cla-Val Repairs

Date: 2/9/2023
 Proposal No. Q306clda
 Page: one of one
 Industry Code: 4952

FOB: Factory
 Terms: N30
 Delivery: 3-4 Weeks

Make Order To: Dorner Company
 N61 W23043 Silver Spring Dr.
 Sussex, WI 53089

Phone No: (262) 932-2100
 Fax No: (262) 932-2101

By: **Jim Ozimek**

Item	Quan.	Description	Unit Price	Total
Pump Control Valves				
1	3	8" Cla-Val Model 136-03-755A Pump Control Valve Repair. Includes: Main Valve Rebuild Kit, X105LCW Limit Switch Assembly, 102C-3H Three Way Pilot Valve, Internal Strainer, 3/4" Swing Check Valve, and Solenoid Valve. Includes Labor Cost For Factory Authorized Technician.	\$ 5,731	\$ 17,194
Altitude Valves				
2	1	8" Cla-Val Model 210-03 Altitude Valve Repair. Includes: Main Valve Rebuild Kit, Replacement Stainless Steel Hardware, CDS6A Altitude Pilot Repair Kit with Lower Stem, 3/8" 81-01 Pilot Check Valve, CVC Flow Control, CV Speed Control, Replacemtn X117D Valve Position Transmitter, and Internal Strainer. Includes Labor Cost For Factory Authorized Technician.	\$ 11,589	\$ 11,589
3	2	12" Cla-Val Model 210-03 Altitude Valve Repair. Includes: Main Valve Rebuild Kit, Replacement Stainless Steel Hardware, CDS6A Altitude Pilot Repair Kit with Lower Stem, 3/8" 81-01 Pilot Check Valve, CVC Flow Control, CV Speed Control, Replacemtn X117D Valve Position Transmitter, and Internal Strainer. Includes Labor Cost For Factory Authorized Technician.	\$ 13,076	\$ 26,152
Total				\$ 54,935

Notes: Prices quoted are FOB Factory with freight pre-pay + add. Quote valid for 30 days. Delivery times are estimated and are not guaranteed.

AGENDA MEMO
Municipal Services Committee
March 27, 2023

ISSUE STATEMENT

A [resolution](#) waiving the competitive bid process and accepting a quote from Landmark Construction Services, Inc., for the City Hall Balcony Deck Remodel Project at 1702 Plainfield Road for the removal of the existing balcony and the material and installation of the replacement balcony deck, in an amount not to exceed \$85,000.00.

AND

A motion for a contingency in the amount of \$5,000 due to unforeseen structural deficiencies items that may be encountered during the building construction.

BACKGROUND

The Budgets for FY22/23 and FY23/24 include funds to remove and replace the City Hall Balcony Deck facing Plainfield Road. The existing balcony’s structure is deteriorating and requires an updated look. Batistich Architects has provided an architectural plan, see [Attachment A](#).

The scope of the work includes the following:

- Staging/Mobilization
- Concrete-Footings Flatwork
- Guard Rail For Deck Railings For Ada Ramp
- Structural Framing-Carpentry
- Balcony Deck Roofing(EDPM-Tapered)
- Exterior Gypsum Board
- Painting
- Landscaping

Staff requested competitive quotes for the bid opening on March 15, 2023. In light of no submitted bids, staff contacted Landmark Construction Services, Inc., and negotiated a quote in the amount of \$85,000, see [Attachment B](#), from a previous pre bid estimate. References for Landmark Construction have been verified with favorable responses.

While the FY22/23 Budget was approved for a \$35,000 architect’s estimate, a preliminary quote was received prior to a bid request in an amount of \$90,000. The revised estimate has been included in the FY23/24 Budget for \$95,000. Much of the increase continues to be due to economic supply and demand issues. Pending FY23/24 Budget approval, the proposed expenditure from the following accounts:

ACCOUNT NUMBER	ACCOUNT DESCRIPTION	FY 23/24 BUDGET	PROPOSED EXPENDITURE	BALANCE
01-30-4223	MAINTENANCE – BUILDING CITY HALL PROJECT	\$95,000	\$85,000	\$10,000
01-30-4223	MAINTENANCE – BUILDING CITY HALL PROJECT - CONTINGENCY		\$ 5,000	\$ 5,000
TOTALS		\$95,000	\$90,000	\$ 5,000

STAFF RECOMMENDATION

Staff recommends approval of a resolution waiving the competitive bid process and accepting a quote from Landmark Construction Services, Inc., for the City Hall Balcony Deck Remodel Project at 1702 Plainfield Road for the removal of the existing balcony and the material and installation of the replacement balcony deck, in an amount not to exceed \$85,000.00.

AND

A motion for a contingency in the amount of \$5,000 due to unforeseen structural deficiencies items that may be encountered during the building construction.

ALTERNATE CONSIDERATION

As directed by the Municipal Services Committee.

DECISION MODE

This item will be placed on the April 3, 2023 City Council agenda for formal approval.

SOUTH ENTRY IMPROVEMENTS:

DARIEN CITY HALL 1702 PLAINFIELD RD. DARIEN, IL

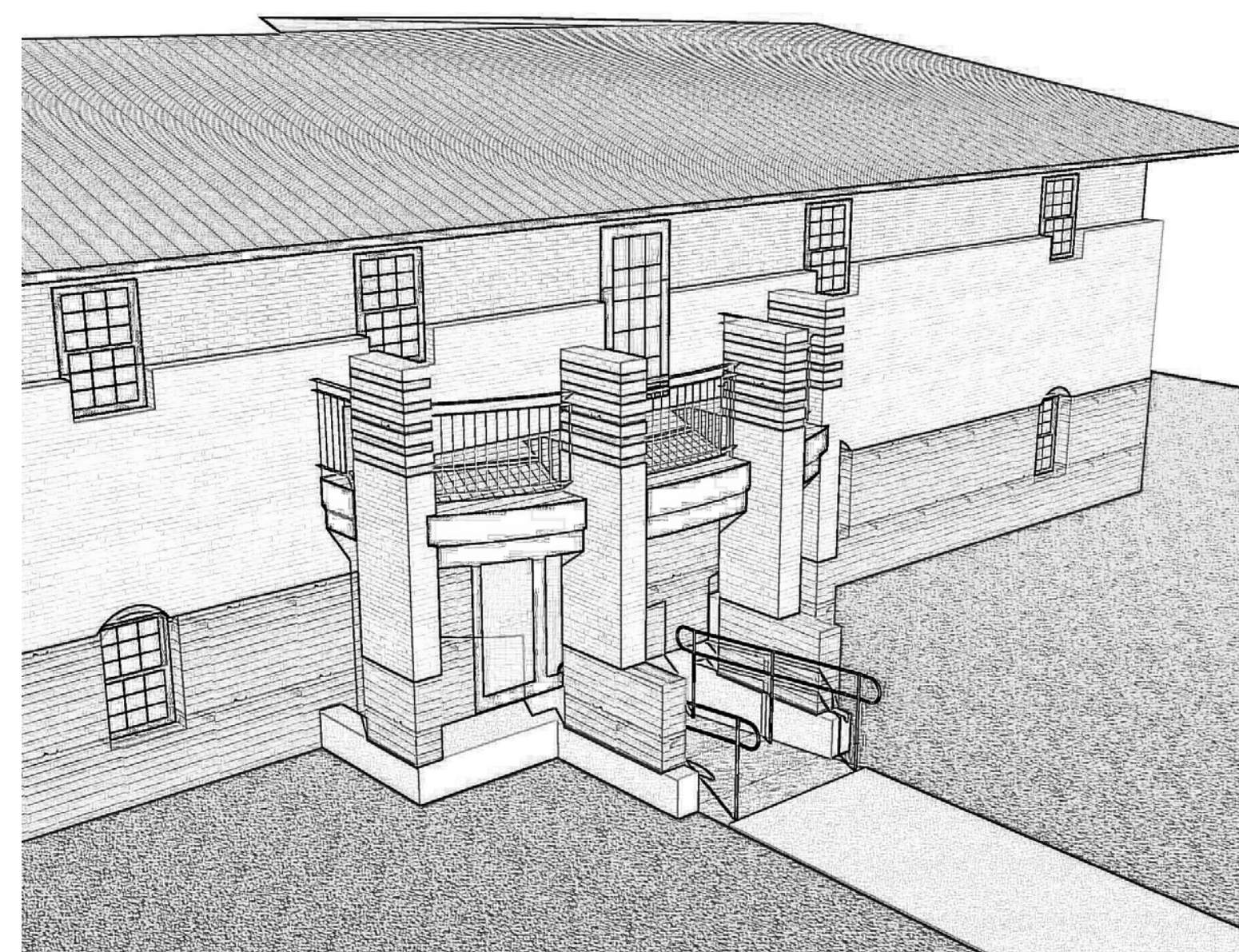

FRONT (SOUTH) ELEVATION

SCALE: 1/8" = 1'-0"

SIDE (EAST) ELEVATION

SCALE: 1/8" = 1'-0"

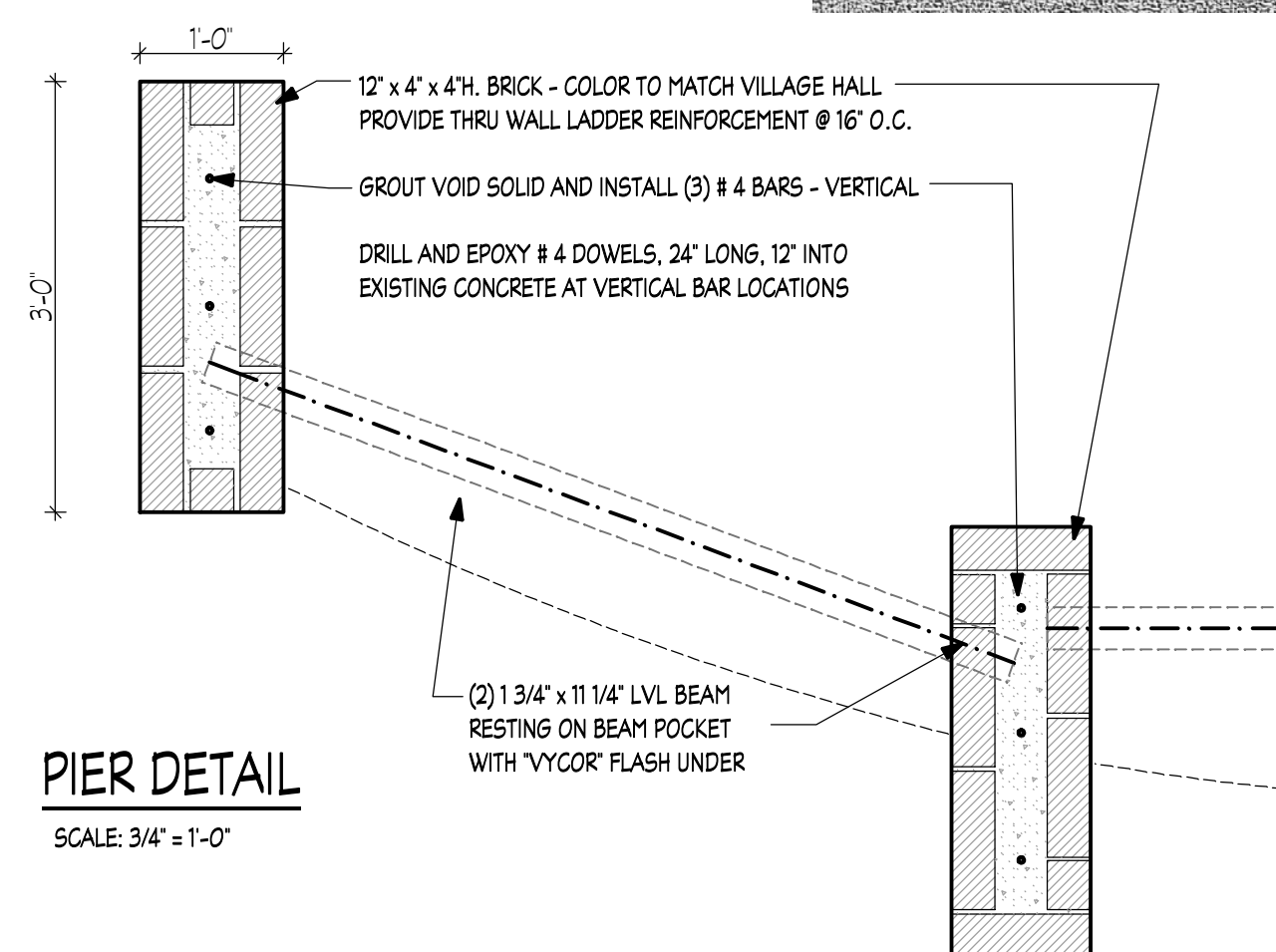

PIER DETAIL

SCALE: 3/4" = 1'-0"

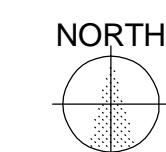
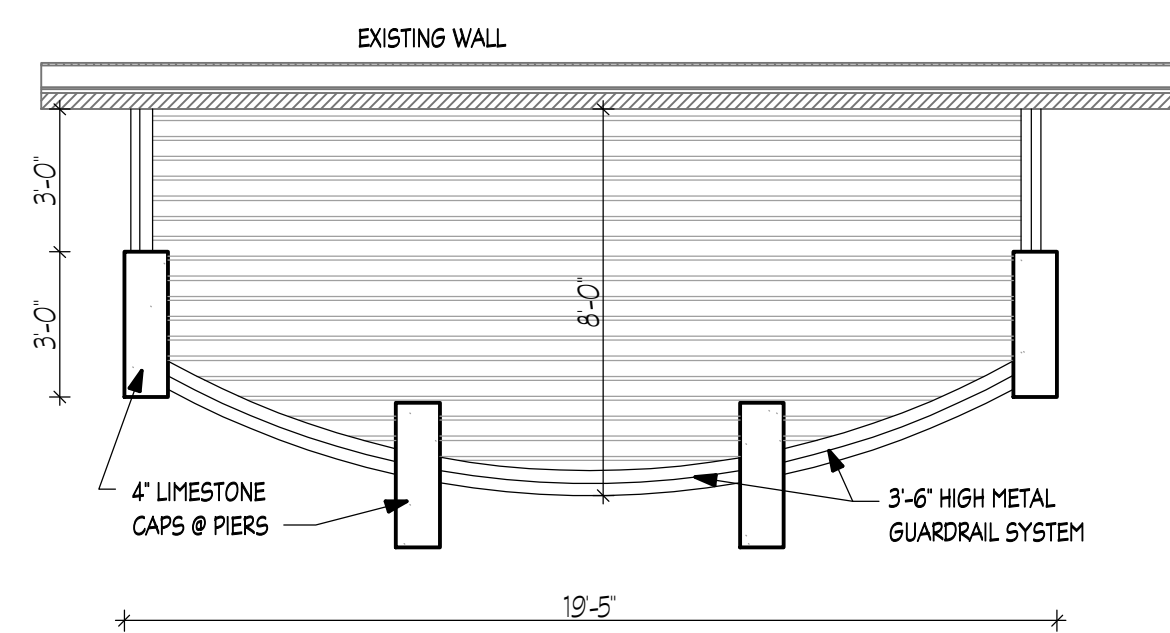

BALCONY PLAN

SCALE: 1/4" = 1'-0"

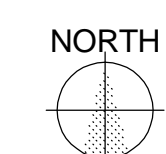
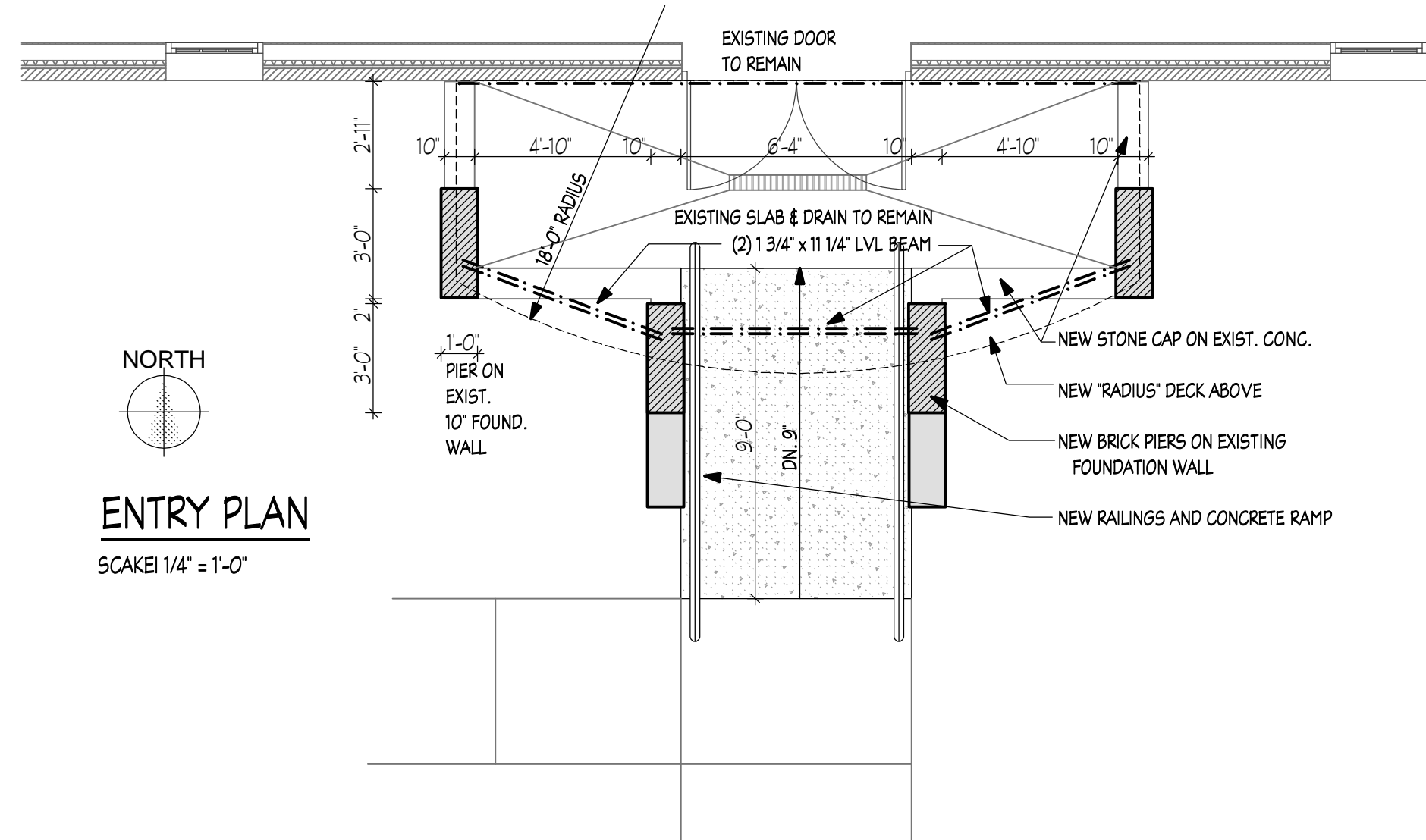

ENTRY PLAN

SCALE: 1/4" = 1'-0"

CONCRETE NOTES

ALL CONCRETE WORK IS TO BE IN COMPLIANCE WITH A.C.I. 318.02.

ALL FOOTINGS SHALL BEAR ON SOLID, UNDISTURBED SOIL OF 3,000 P.S.F. BEARING CAPACITY. NO CONCRETE SHALL BE POURED IN EXCAVATIONS CONTAINING WATER OR SOLID GROUND.

ALL CONCRETE SHALL HAVE A MINIMUM ULTIMATE COMPRESSIVE STRENGTH OF 3000 P.S.I. AT 28 DAYS, 3" MINIMUM SLUMP, WITH A MINIMUM OF 6 BAGS OF CEMENT PER CUBIC YARD OF CONCRETE, NOT MORE THAN 6 GALLONS OF WATER PER BAG OF CEMENT.

REINFORCING BAR MATERIAL SHALL CONFORM TO A.S.T.M. A 615, GRADE 60. WELDED WIRE FABRIC SHALL CONFORM TO A.S.T.M. A 185.

REINFORCING DESIGN AND PLACEMENT SHALL BE ACCORDING TO A.C.I. 315. PROVIDE FOUNDATION WALL CORNER BAR EQUAL IN SIZE TO HORIZONTAL REINFORCING. PROVIDE CHAIRS TO SUPPORT REINFORCING. PROVIDE A MINIMUM OF 2" COVER ON ALL REINFORCING UNLESS OTHERWISE SPECIFIED.

BUILT-UP ITEMS SUCH AS INSERTS, ANCHOR BOLTS, SLEEVES, ETC. SHALL BE COORDINATED WITH OTHER TRADES PRIOR TO PLACEMENT OF CONCRETE.

MASONRY NOTES

NEW FACE BRICK IS TO MATCH THE EXISTING FACE BRICK

HOLLOW CONCRETE BLOCK UNITS SHALL BE PER ASTM C 90. MINIMUM NET AREA COMPRESSIVE STRENGTH OF CMU = 2000 PSI

MORTAR IS TO CONFORM TO ASTM C 270 TYPE N WITH A MINIMUM COMPRESSIVE STRENGTH OF 750 P.S.I. MATCH MORTAR COLOR WITH THAT OF THE EXISTING MORTAR

MASONRY REINFORCEMENT PER ASTM A 82, DUR-O-WAL OR EQUAL GALVANIZED TRUSS TYPE ADJUSTABLE JOINT REINFORCING WITH EYES FOR CAVITY INSULATED WALLS AT 16' O.C.

LAY MASONRY UNITS PLUMB AND TRUE TO LINES

LAY WITH COMPLETELY FILLED MORTAR JOINTS

DO NOT FURROW BED JOINTS

CALCIUM CHLORIDE OR SIMILAR ADMIXTURES SHALL NOT BE USED EXCEPT WHEN APPROVED IN WRITING BY THE ARCHITECT.

MASONRY WALLS SHALL BE ADEQUATELY BRACED AGAINST WIND DURING CONSTRUCTION AND UNTIL FRAMING MEMBERS ARE IN PLACE

GROUT NOTES

GROUT FOR VERTICAL REINF. WALLS, BOND BEAMS, FILLED BLOCK, AND ANCHOR BOLTS SHALL CONFORM TO THE FOLLOWING

- 1 PORTLAND CEMENT - 1 PART BY VOLUME
- 2 HYDRATED LIME OR LIME PUTTY - 1/10 PART BY VOLUME
- 3 CLEAN SHARP SAND - 3 TIMES THE SUM OF VOLUMES 1 AND 2.

GROUT SHALL DEVELOP A COMPRESSIVE STRENGTH OF 3000 PSI IN 28 DAYS

GROUT SHALL BE PUDDLED AS NECESSARY TO ENSURE A COMPLETE BOND. PERMIT SUFFICIENT TIME BETWEEN LIFTS TO AVOID BLOWOUTS

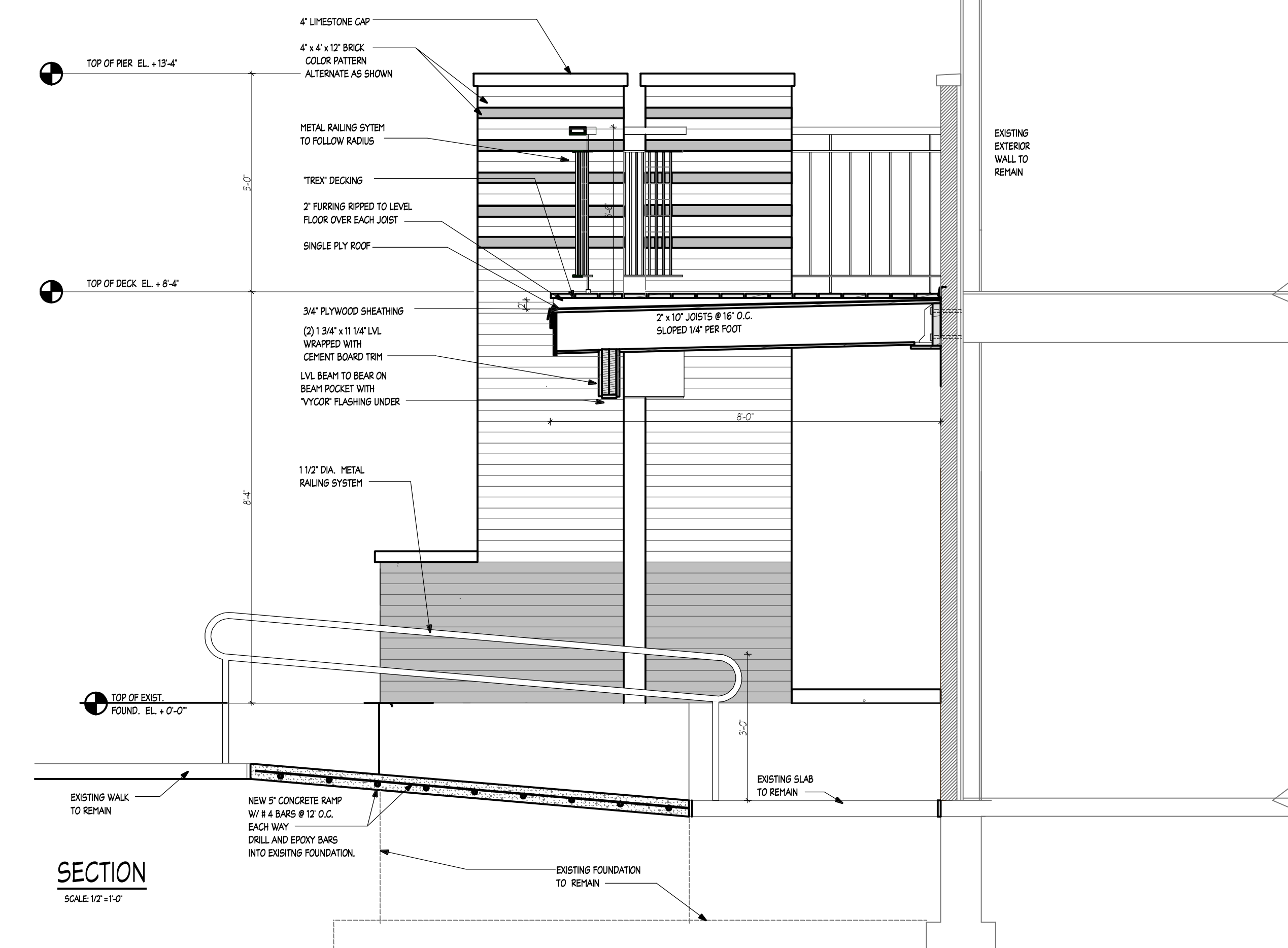

SECTION

SCALE: 1/2" = 1'-0"

n. battistich, architects
MEADOWBROOK OFFICE CENTER
16W475 S. FRONTAGE RD., SUITE 201
BURK RIDGE, IL 60527 (630) 966-1773
IL DESIGN FIRM LIC. NO. 184.004493

I HEREBY CERTIFY THAT THESE PLANS WERE PREPARED BY ME OR UNDER MY SUPERVISION AND THAT THEY COMPLY TO THE BEST OF MY KNOWLEDGE AND BELIEF WITH THE REQUIREMENTS OF THE APPLICABLE BUILDING CODES

DO NOT SCALE DRAWINGS
CONTRACTOR SHALL VERIFY ALL PLAN DIMENSIONS AND SHALL BE RESPONSIBLE FOR ANY DISCREPANCIES BEFORE PROCEEDING WITH WORK OR BE RESPONSIBLE FOR SAME

DATE	DRAWN BY	SCALE	APPROVED BY

REVISIONS

PLAN No.	SHEET No.





SOUTH ENTRY IMPROVEMENTS
DARIEN CITY HALL
1702 Plainfield Road
Darien, IL 60561

PROJECT COST ESTIMATE
January 31, 2023

General conditions.....	\$ 3,500
Demolition.....	\$ 3,500
Landscape restoration (allowance).....	\$ 2,000
Concrete work.....	\$ 8,755
Masonry.....	\$ 29,800
Railings (alum balcony, SS handrail).....	\$ 9,960
Structural framing/carpentry.....	\$ 14,750
Roofing (EDPM – tapered).....	\$ 5,300
Exterior gypsum board.....	\$ 1,600
Painting.....	\$ 1,185
	<u>Subtotal</u> \$ 80,350
	General Liability Insurance <u>\$ 650</u>
	Total \$ 81,000
	G.C.Fee <u>\$ 9,000</u>
	Project Total \$ 90,000

Exclusions: Tax, decking, electrical

RESOLUTION NO. _____

A RESOLUTION WAIVING THE COMPETITIVE BID PROCESS AND ACCEPTING A QUOTE FROM LANDMARK CONSTRUCTION SERVICES, INC., FOR THE CITY HALL BALCONY DECK REMODEL PROJECT AT 1702 PLAINFIELD ROAD FOR THE REMOVAL OF THE EXISTING BALCONY AND THE MATERIAL AND INSTALLATION OF THE REPLACEMENT BALCONY DECK, IN AN AMOUNT NOT TO EXCEED \$85,000.00

BE IT RESOLVED BY THE CITY COUNCIL OF THE CITY OF DARIEN, DU PAGE COUNTY, ILLINOIS, as follows:

SECTION 1: The City Council of the City of Darien hereby authorizes waiving the competitive bid process and accepting a quote from Landmark Construction Services, Inc., for the City Hall Balcony Deck Remodel Project at 1702 Plainfield Road for the removal of the existing balcony and the material and installation of the replacement balcony deck, in an amount not to exceed \$85,000.00, a copy of which is attached hereto as "[Exhibit A](#)".

SECTION 2: This Resolution shall be in full force and effect from and after its passage and approval as provided by law.

PASSED BY THE CITY COUNCIL OF THE CITY OF DARIEN, DU PAGE COUNTY, ILLINOIS, this 3rd day of April, 2023.

AYES: _____

NAYS: _____

ABSENT: _____

APPROVED BY THE MAYOR OF THE CITY OF DARIEN, DU PAGE COUNTY, ILLINOIS, this 3rd day of April, 2023.

JOSEPH MARCHESE, MAYOR

ATTEST:

JOANNE E. RAGONA, CITY CLERK

APPROVED AS TO FORM:

CITY ATTORNEY



SECTION II

BIDDER SUMMARY SHEET

2023 City Hall Balcony Deck Remodel Project

Firm Name: LANDMARK CONSTRUCTION SERVICES, INC.

Address: 18606 S. 81ST AVENUE

City, State, Zip Code: TINLEY PARK, ILLINOIS 60487

Contact Person: JAY BRADARICH

FEIN #: 36-1085996

Phone: (708) 342-0466 Fax: (708) 342-0468

Mobile: (708) 774-0070

E-mail Address: JAYB@LANDMARKCSI.COM

RECEIPT OF ADDENDA: The receipt of the following addenda is hereby acknowledged:

Addendum No. NONE, Dated _____

Addendum No. NONE, Dated _____

Schedule of Prices for:

SUMMARY SCHEDULE

All bids shall be sealed and returned prior to the bid opening at 9:00 a.m. on Wednesday, March 15, 2023 at the City of Darien, 1702 Plainfield Road, Darien, Illinois, 60561.

NO.	DESCRIPTION	QUANTITY	UNIT	TOTAL COST
1.	DEMOLITION STAGING/MOBILIZATION	1	LUMP SUM	7,189
2.	CONCRETE-FOOTINGS FLATWORK	1	LUMP SUM	9,130
3.	GUARD RAIL FOR DECK RAILINGS FOR ADA RAMP	1	LUMP SUM	10,507
4 5	MASONRY CARPENTRY	1 1	LUMP SUM LUMP SUM	32,074 15,484
6	BALCONY DECK ROOFING(EDPM-Tapered)	1	LUMP SUM	5,309
7	EXTERIOR GYPSUM BOARD	1	LUMP SUM	1,770
8	PAINTING	1	LUMP SUM	1,325
9	LANDSCAPING	1	LUMP SUM	2,212
10.	TOTAL PROJECT COST			\$85,000

Total Project Cost in written form: EIGHTY-FIVE THOUSAND DOLLARS

Below, please find an item description of the abovementioned:

- 1 - This item will include the following:
 - Mobilization/Staging
 - Portable bathroom
 - Dumpster(s)
 - Barricades/safety cones as required
 - Unit of measurement for pay item is lump sum

- 2- This item will include the following:
 - Removal of existing concrete sidewalk
 - Placement of forms
 - Placement and finishing of the footings and /or concrete sidewalk
 - Unit of measurement for pay item is lump sum

- 3 - This item will include the following:
 - Guard rail and handrail system for balcony deck-commercial grade-powder coated color to be determined
 - Handrail system for ramp to comply with the American with Disabilities Act for sidewalk at ramps and the insertion of the truncated dome if required.
 - Unit of measurement for pay item is lump sum

4. THIS ITEM TO INCLUDE THE FOLLOWING:
- ALL STRUCTURAL PINPOINT PIERS AS SHOWN OR CALLED FOR AND AS REQUIRED.
 - UNIT OF MEASUREMENT FOR PAY IS LUMP SUM
- 5- This item will include the following:
- All structural and framing materials and approved fasteners as required
 - Placement and finishing as required of all structural and framing
 - Unit of measurement for pay item is lump sum
- 6- This item will include the following:
- Balcony roof deck system preparation and installation of EDPM-Tapered
 - Placement and finishing as required
 - Unit of measurement for pay item is lump sum
- 7- This item will include the following:
- Exterior rated gypsum board, vapor barrier as required and fasteners
 - Placement and finishing as per manufacturers specification
 - Unit of measurement for pay item is lump sum
- 8- This item will include the following:
- Painting-prime and two coats of a Sherwin Williams or equivalent paint system
 - Placement and finishing to dovetail to existing façade. Color to be determined
 - Unit of measurement for pay item is lump sum
- 9- This item will include the following:
- Landscaping-All disturbed landscaping will require replacement in alike and turf restoration will consist of 4-inches of topsoil, sod and starter fertilizer.
 - Unit of measurement for pay item is lump sum
- 10- The contract shall be awarded on a **Total Sum** based on the unit cost of 1-8.

END OF SPECIFICATION

Firm Name: JAY M. BRADANCH, SR.

Signature of Authorized Representative: 

Title: PRESIDENT Date: 3-16-23

ACCEPTANCE: This proposal is valid for 120 calendar days from the date of submittal.

CITY OF DARIEN

CONTRACT

This Contract is made this 16th day of MARCH, 2023 by and between the City of Darien (hereinafter referred to as the "CITY") and LANDMARK CONSTRUCTION SERVICES, INC. (Hereinafter referred to as the "CONTRACTOR").

WITNESSETH

In consideration of the promises and covenants made herein by the CITY and the CONTRACTOR (hereinafter referred to collectively as the "PARTIES"), the PARTIES agree as follows:

SECTION 1: THE CONTRACT DOCUMENTS: This Contract shall include the following documents (hereinafter referred to as the "CONTRACT DOCUMENTS") however this Contract takes precedence and controls over any contrary provision in any of the CONTRACT DOCUMENTS. The Contract, including the CONTRACT DOCUMENTS, expresses the entire agreement between the PARTIES and where it modifies, adds to or deletes provisions in other CONTRACT DOCUMENTS; the Contract's provisions shall prevail. Provisions in the CONTRACT DOCUMENTS unmodified by this Contract shall be in full force and effect in their unaltered condition.

The Invitation to Bid

The Instructions to the Bidders

This Contract

The Terms and Conditions

The Bid as it is responsive to the CITY'S bid requirements

All Certifications required by the City

Certificates of insurance

Performance and Payment Bonds as may be required by the CITY *(NOT INCLUDED IN BID)*

SECTION 2: SCOPE OF THE WORK AND PAYMENT: The CONTRACTOR agrees to provide labor, equipment and materials necessary to provide the services as described in the CONTRACT DOCUMENTS and further described below:

Unit Pricing for the 2023 Balcony Deck Remodeling Project (Hereinafter referred to as the "WORK") and the CITY agrees to pay the CONTRACTOR pursuant to the provisions of the Local Government Prompt Payment Act (50 ILCS 505/1 *et seq.*) the following amount for performance of the described unit prices.

SECTION 3: ASSIGNMENT: CONTRACTOR shall not assign the duties and obligations involved in the performance of the WORK which is the subject matter of this Contract without the written consent of the CITY.

SECTION 4: TERM OF THE CONTRACT: This Contract shall commence on the date of its execution. The WORK shall commence upon receipt of a Notice to Proceed and continue for the period specified. This Contract shall terminate upon completion of the WORK, but may be terminated by either of the PARTIES for default upon failure to cure after ten (10) days prior written notice of said default from the aggrieved PARTY. The CITY, for its convenience, may terminate this Contract with thirty (30) days prior written notice.

SECTION 5: INDEMNIFICATION AND INSURANCE: The CONTRACTOR shall indemnify and hold harmless the CITY, its officials, officers, directors, agents, employees and representatives and assigns, from lawsuits, actions, costs (including attorneys' fees), claims or liability of any character, incurred due to the alleged negligence of the CONTRACTOR, brought because of any injuries or damages received or sustained by any person, persons or property on account of any act or omission, neglect or misconduct of said CONTRACTOR, its officers, agents and/or employees arising out

of, or in performance of any of the provisions of the CONTRACT DOCUMENTS, including any claims or amounts recovered for any infringements of patent, trademark or copyright; or from any claims or amounts arising or recovered under the "Worker's Compensation Act" or any other law, ordinance, order or decree. In connection with any such claims, lawsuits, actions or liabilities, the CITY, its officials, officers, directors, agents, employees, representatives and their assigns shall have the right to defense counsel of their choice. The CONTRACTOR shall be solely liable for all costs of such defense and for all expenses, fees, judgments, settlements and all other costs arising out of such claims, lawsuits, actions or liabilities. The Contractor shall not make any settlement or compromise of a lawsuit or claim, or fail to pursue any available avenue of appeal of any adverse judgment, without the approval of the City and any other indemnified party. The City or any other indemnified party, in its or their sole discretion, shall have the option of being represented by its or their own counsel. If this option is exercised, then the Contractor shall promptly reimburse the City or other indemnified party, upon written demand, for any expenses, including but not limited to court costs, reasonable attorneys' and witnesses' fees and other expenses of litigation incurred by the City or other indemnified party in connection therewith. Execution of this Contract by the CITY is contingent upon receipt of Insurance Certificates provided by the CONTRACTOR in compliance with the CONTRACT DOCUMENTS.

SECTION 6: COMPLIANCE WITH LAWS: The bidder shall at all times observe and comply with all laws, ordinances and regulations of the federal, state, local and City governments, which may in any manner affect the preparation of bids or the performance of the Contract. Bidder hereby agrees that it will comply with all requirements of the Illinois Human Rights Act, 775 ILCS 5/1-101 et seq., including the provision dealing with sexual harassment and that if awarded the Contract will not engage in any prohibited form of discrimination in employment as defined in that Act and will require that its subcontractors agree to the same restrictions. The contractor shall maintain, and require that its subcontractors maintain, policies of equal employment opportunity which shall prohibit discrimination against any employee or applicant for employment on the basis of race, religion, color, sex, national origin, ancestry, citizenship status, age, marital status, physical or mental disability unrelated to the individual's ability to perform the essential functions of the job, association with a person with a disability, or unfavorable discharge from military service. Contractors and all subcontractors shall comply with all requirements of the Act and of the Rules of the Illinois Department of Human Rights with regard to posting information on employees' rights under the Act. Contractors and all subcontractors shall place appropriate statements identifying their companies as equal opportunity employers in all advertisements for workers to be employed in work to be performed. Not less than the Prevailing Rate of Wages as found by the City of Darien or the Department of Labor shall be paid to laborers, workmen, and mechanics performing work under the Contract. If awarded the Contract, contractor must comply with all provisions of the Illinois Prevailing Wage Act, including, but not limited to, providing certified payroll records to the Municipal Services Department. Contractor and subcontractors shall be required to comply with all applicable federal laws, state laws and regulations regarding minimum wages, limit on payment to minors, minimum fair wage standards for minors, payment of wage due employees, and health and safety of employees. Contractor and subcontractor are required to pay employees all rightful salaries, medical benefits, pension and social security benefits pursuant to applicable labor agreements and federal and state statutes and to further require withholdings and deposits therefore. The CONTRACTOR shall obtain all necessary local and state licenses and/or permits that may be required for performance of the WORK and provide those licenses to the CITY prior to commencement of the WORK if applicable.

SECTION 7: NOTICE: Where notice is required by the CONTRACT DOCUMENTS

it shall be considered received if it is delivered in person, sent by registered United States mail, return receipt requested, delivered by messenger or mail service with a signed receipt, sent by facsimile or e-mail with an acknowledgment of receipt, to the following:

City of Darien
1702 Plainfield Road
Darien, IL 60561
Attn: Director of Municipal Services

SECTION 8: STANDARD OF SERVICE: Services shall be rendered to the highest professional standards to meet or exceed those standards met by others providing the same or similar services in the Chicagoland area. Sufficient competent personnel shall be provided who with supervision shall complete the services required within the time allowed for performance. The CONTRACTOR'S personnel shall, at all times present a neat appearance and shall be trained to handle all contact with City residents or City employees in a respectful manner. At the request of the Director of Municipal Services or a designee, the CONTRACTOR shall replace any incompetent, abusive or disorderly person in its employ.

SECTION 9: PAYMENTS TO OTHER PARTIES: The CONTRACTOR shall not obligate the CITY to make payments to third parties or make promises or representations to third parties on behalf of the CITY without prior written approval of the City Administrator or a designee.

SECTION 10: COMPLIANCE: CONTRACTOR shall comply with all of the requirements of the Contract Documents, including, but not limited to, the Illinois Prevailing Wage Act where applicable and all other applicable local, state and federal statutes, ordinances, codes, rules and regulations.

SECTION 11: LAW AND VENUE: The laws of the State of Illinois shall govern this Contract and venue for legal disputes shall be DuPage County, Illinois.

SECTION 12: MODIFICATION: This Contract may be modified only by a written amendment signed by both PARTIES.

FOR: THE CITY

FOR: THE CONTRACTOR

By: _____

By:  _____

Print Name: _____

Print Name: JAY M. BLAWIECK, SR.

Title: Mayor

Title: PRESIDENT

Date: _____

Date: 3-16-23

**MINUTES
CITY OF DARIEN
MUNICIPAL SERVICES COMMITTEE MEETING
February 27, 2023**

PRESENT: Alderman Thomas Belczak -Chairman, Alderman Eric Gustafson, Alderman Joseph Kenny, Dan Gombac – Director

ABSENT: None

ESTABLISH QUORUM

Chairperson Thomas Belczak called the meeting to order at 6:01 p.m. at the City of Darien City Hall, 1702 Plainfield Road, Darien, Illinois. Chairperson Belczak declared a quorum present.

NEW BUSINESS

a. Resolution - Approving the 2023 City of Darien Zoning Map for publication.

Mr. Dan Gombac, Director reported that every year the City updates the Zoning Map to show all the properties approved during the previous calendar year. He reported that the Committee received a listing of the nine approvals in 2022, including one special use, two special use variation cases, and six additional variation cases.

There was no one in the audience wishing to present public comment.

Alderman Kenny made a motion, and it was seconded by Alderman Gustafson approving a Resolution for the 2023 City of Darien Zoning Map for publication.

Upon voice vote, the MOTION CARRIED UNANIMOUSLY 3-0.

b. Ordinance – Approval to amend the liquor code to expand the number of Class D liquor licenses from ten (10) to eleven (11) for a sale and serve liquor license at Harmi Sushi.

Mr. Dan Gombac, Director reported that Mayor Marchese received a request from Harmi Sushi restaurant for a sale and serve liquor license for on-site consumption only of beer and wine. He reported that the license required for the request is a D License and would increase the number of D licenses from ten to eleven and that Mayor Marchese as Liquor Commissioner has indicated he supports the request.

There was no one in the audience wishing to present public comment.

Alderman Gustafson made a motion, and it was seconded by Alderman Kenny approval of an Ordinance to amend the liquor code to expand the number of Class D liquor licenses from ten (10) to eleven (11) for a sale and serve liquor license at Harmi Sushi.

Upon voice vote, the MOTION CARRIED UNANIMOUSLY 3-0.

c. Resolution – Authorizing the Mayor to enter into a contract with Orange Crush, LLC for the 2023 Street Program as per the following schedule of pricing, pending 2023/24 Budget approval; Base bid - \$,206,402.75; alternate 1 - patching - \$108,000.00; alternate 2 – Darien Club Dr., Limerick Ct., and Galway Ct.; for a total of \$1,897,642.50.

Mr. Dan Gombac, Director reported that this year's 2023 Street Maintenance Program includes 5.2 miles to be resurfaced. He reported that typically the City averages approximately 5 miles of resurfacing per year but that this year's program includes the following,

Alternate 1 - Patching \$108,000.00 – Includes the removal and replacement of road base throughout the City due to failing base.

Alternate 2 – Darien Club Dr., Limerick Ct., and Galway Ct.

Mr. Gombac reported that six bids were received and that the lowest responsive bid for the Base Bid was Orange Crush, LLC in the amount of \$1,206,402.75. He reported that with the Base Bid, Alternate 1 and 2 Orange Crush, LLC is the awarded responsive bidder, pending budget approval: \$1,897,642.50. He further reported that Orange Crush, LLC has completed satisfactory work for the City.

There was no one in the audience wishing to present public comment.

Alderman Kenny made a motion, and it was seconded by Alderman Gustafson approval of a Resolution authorizing the Mayor to enter into a contract with Orange Crush, LLC for the 2023 Street Program as per the following schedule of pricing, pending 2023/24 Budget approval; Base bid - \$,206,402.75; alternate 1 - patching - \$108,000.00; alternate 2 – Darien Club Dr., Limerick Ct., and Galway Ct.; for a total of \$1,897,642.50.

Upon voice vote, the MOTION CARRIED UNANIMOUSLY 3-0.

d. Resolution - Accepting the unit price proposal for analytical soil testing fees from Clean Soils Consulting, LLC at the proposed unit prices for certain waste for a period of May 1, 2023 through April 30, 2024.

Mr. Dan Gombac, Director reported that during the year, the department generates excavated materials from various Public Works projects, such as water main breaks, valve and hydrant replacements, landscape restorations and ditching projects. He reported that the Clean Construction or Demolition Debris (CCDD) law requires the Illinois EPA to propose rules to establish technical requirements for CCDD facilities; set operating standards for uncontaminated soil fill operations; and develop standards for the maximum allowable concentrations of chemical constituents in uncontaminated soil generated during construction or demolition activities and used as fill material.

Mr. Gombac reported that competitive quotes for the required analytical testing services were received and that the lowest bid was provided by Clean Soils Consulting, LLC. He reported that the pricing is to be held in place from May 1, 2023 to April 30, 2024 and that the expenditure

will come from the Water, Street and Capital accounts, depending on the specific project generating the waste. Mr. Gombac reported that total estimated costs for all maintenance and budgetary programs for this item are \$26,000.00.

There was no one in the audience wishing to present public comment.

Alderman Gustafson made a motion, and it was seconded by Alderman Kenny approval of a Resolution accepting the unit price proposal for analytical soil testing fees from Clean Soils Consulting, LLC at the proposed unit prices for certain waste for a period of May 1, 2023 through April 30, 2024.

Upon voice vote, the MOTION CARRIED UNANIMOUSLY 3-0.

e. Resolution – Awarding a contract to Yellowstone Landscape Group in an amount not to exceed \$178,267.50 for the City's 2023/24 Tree Trimming and Removal Program.

Mr. Dan Gombac, Director reported that the proposed tree trimming program consists of trimming approximately 1,750 parkway trees, approximately 65 tree removals and stump grinding. He reported that this year's program includes contract pricing for the Private Property Tree Trimming Program to all the residents.

There was no one in the audience wishing to present public comment.

Alderman Kenny made a motion, and it was seconded by Alderman Gustafson approval of a Resolution awarding a contract to Yellowstone Landscape Group in an amount not to exceed \$178,267.50 for the City's 2023/24 Tree Trimming and Removal Program.

Upon voice vote, the MOTION CARRIED UNANIMOUSLY 3-0.

f. Resolution - Authorizing the Mayor to execute a contract extension with SKC Construction, Inc. in an amount not to exceed \$227,580.00 for the 2023 Crack Fill Program.

Mr. Dan Gombac, Director reported that the FY 23/24 Budget includes funds for the 2023 Crack Fill Program. He reported that crack sealing is a routine maintenance treatment that will significantly delay roadway deterioration.

There was some discussion regarding marketing the program in Direct Connect.

There was no one in the audience wishing to present public comment.

Alderman Kenny made a motion, and it was seconded by Alderman Gustafson approval of a Resolution authorizing the Mayor to execute a contract extension with SKC Construction, Inc. in an amount not to exceed \$227,580.00 for the 2023 Crack Fill Program.

Upon voice vote, the MOTION CARRIED UNANIMOUSLY 3-0.

g. Resolution - Approving a contract extension with SKC Construction, Inc. in an amount not to exceed \$15,000 for the 2023 city hall parking lot seal coating and striping.

Mr. Dan Gombac, Director reported that in 2022, the City of Darien teamed up with local public agencies and solicited competitive bids, collectively and that this would be the first extension of a three-year program. He reported that the City Hall parking lot is scheduled for sealcoating and striping this year and would be awarded to the proposed vendor at the submitted unit prices.

There was no one in the audience wishing to present public comment.

Alderman Gustafson made a motion, and it was seconded by Alderman Kenny approval of a Resolution approving a contract extension with SKC Construction, Inc. in an amount not to exceed \$15,000 for the 2023 city hall parking lot seal coating and striping.

Upon voice vote, the MOTION CARRIED UNANIMOUSLY 3-0.

h. Resolution – Accepting a proposal from Rags Electric to install a backup electrical disconnect and generator plug-in at the 75th Street Pumping Station in an amount of \$11,155.00.

Mr. Dan Gombac, Director reported that the City's water system has the capability to flow through two incoming lines from the DuPage Water Commission transmission lines, one adjacent to the Plainfield Road water tower and the second line is adjacent to the pumping station located on 75th Street, fronting Home Depot. He reported that in the event of a power loss, a backup diesel generator is on standby at the Plainfield Road pumping station and that the generator will run the entire plant in the event of a power loss from ComEd.

Mr. Gombac reported that the 75th Street Pumping Station is equipped with pumps that were installed several years ago to maintain optimal system pressure for the southwest quadrant of town and that the facility does not have any backup power capabilities. He reported that the proposed backup electrical switching equipment would allow for a mobile generator to be brought in, in the event additional pumps are required to satisfy water demand.

There was no one in the audience wishing to present public comment.

Alderman Kenny made a motion, and it was seconded by Alderman Gustafson approval of a Resolution accepting a proposal from Rags Electric to install a backup electrical disconnect and generator plug-in at the 75th Street Pumping Station in an amount of \$11,155.00.

Upon voice vote, the MOTION CARRIED UNANIMOUSLY 3-0.

i. Motion - Authorizing a contingency in the amount of \$2,000 for restoration and unforeseen work that may be required for the backup electrical disconnect.

Mr. Dan Gombac, Director reported that a contingency in the amount of \$2,000 for restoration and unforeseen work that may be required for the backup electrical disconnect.

There was no one in the audience wishing to present public comment.

Alderman Kenny made a motion, and it was seconded by Alderman Gustafson authorizing a contingency in the amount of \$2,000 for restoration and unforeseen work that may be required for the backup electrical disconnect.

Upon voice vote, the MOTION CARRIED UNANIMOUSLY 3-0.

j. Resolution - Authorizing the purchase of one (1) new Caterpillar Model: 305-07CR Mini Hydraulic Excavator, from ALTORFER CAT in an amount not to exceed \$90,050.

Mr. Dan Gombac, Director reported that the Water Division currently utilizes a standard backhoe/loader, combination machine, for day to day excavations, backfilling and loading. He reported that the backhoe is typically utilized to dig infrastructure from 1 foot to approximately 10 foot in depth.

Mr. Gombac reported that while the FY22/23 Budget includes funding for the machine it will be over budget by approximately \$30,000 and that City Staff has been informed that the pricing will be increasing May 1, 2023 by a minimal of 10%. He reported that the dealer has the proposed machine in their inventory and would hold for the City until March 7, 2023 and that the water fund account balance has the ability to absorb the shortfall.

There was no one in the audience wishing to present public comment.

Alderman Belczak made a motion, and it was seconded by Alderman Gustafson approval of a Resolution authorizing the purchase of one (1) new Caterpillar Model: 305-07CR Mini Hydraulic Excavator, from ALTORFER CAT in an amount not to exceed \$90,050.

Upon voice vote, the MOTION CARRIED UNANIMOUSLY 3-0.

k. Resolution – Accepting proposal from Rag’s Electric professional design services related to the Geographic Information Systems (GIS) Mapping for Streetlights and infrastructure in an amount not to exceed \$14,000.

Mr. Dan Gombac, Director reported that during the course of the last 5 years the Department has been planning and implementing a GIS Mapping system as it relates to the City's potable water infrastructure, storm water and zoning for the City of Darien. He reported that the next project is to field identify coordinates for the City's streetlights and underground cabling and

that the continued utilization of GIS system allows the departments' greater efficiency, to locate, infrastructure for routine and emergency situations.

Mr. Gombac reported that Rag's Electric is currently the City's street lighting contractor and has agreed to perform the identified task at the 2022 approved unit pricing and that this item was budgeted for FY22/23.

There was no one in the audience wishing to present public comment.

Alderman Kenny made a motion, and it was seconded by Alderman Gustafson approval of a Resolution accepting proposal from Rag's Electric professional design services related to the Geographic Information Systems (GIS) Mapping for Streetlights and infrastructure in an amount not to exceed \$14,000.

Upon voice vote, the MOTION CARRIED UNANIMOUSLY 3-0.

I. Resolution - Approving to enter a contract with TruGreen Limited Partnership for six (6) various fertilizer applications and (3) three applications for planting beds and weed control, within rip rap areas and tree fertilization for 75th Street, in an amount not to exceed \$76,756.00 for the 2023 Landscape Fertilization Services.

Mr. Dan Gombac, Director reported that the City's fertilization program will allow the City to eradicate noxious weeds and provide uniform aesthetically pleasing turf throughout certain right of ways and City owned facilities. He reported that the fertilization program includes the treatment of maintaining weed free planting beds throughout the City.

Mr. Gombac reported that one bid was received for the proposed fertilization services and that the contract also called out for two optional extensions for 2024 and 2025.

There was no one in the audience wishing to present public comment.

Alderman Belczak made a motion, and it was seconded by Alderman Gustafson approval of a Resolution to enter a contract with TruGreen Limited Partnership for six (6) various fertilizer applications and (3) three applications for planting beds and weed control, within rip rap areas and tree fertilization for 75th Street, in an amount not to exceed \$76,756.00 for the 2023 Landscape Fertilization Services.

Upon voice vote, the MOTION CARRIED UNANIMOUSLY 3-0.

m. Resolution – Authorizing the purchase of the Phase 1-Leak Logger Program, consisting of fifty-two leak logger units from Gutermann Inc., in an amount not to exceed \$58,965.

Mr. Dan Gombac, Director reported that proposed leak detection system would be utilized by the Water Division to proactively locate and pinpoint leaks while they are small. Mr. Gombac reported that the loggers will provide monitoring 24 hours per day 365 days a year and that the program is considered Phase 1 of 4 and is budgeted over a four-year program, pending budget considerations.

Mr. Gombac reported that the cost of the entire program will be approximately \$616,000 with reoccurring costs after the initial five years of each phase and that the program would pay for itself in 2.25 to 2.5 years. He reported that the reoccurring costs would be budget beginning 2027/2028.

Chairperson Tom Belczak questioned why scatter the costs.

Mr. Gombac reported that the product is new with training and that staff wants to be fiscally responsible staying in line with the budget.

There was no one in the audience wishing to present public comment.

Alderman Kenny made a motion, and it was seconded by Alderman Gustafson approval of Resolution authorizing the purchase of the Phase 1-Leak Logger Program, consisting of fifty-two leak logger units from Gutermann Inc., in an amount not to exceed \$58,965.

Upon voice vote, the MOTION CARRIED UNANIMOUSLY 3-0.

n. Minutes – December 19, 2022 Municipal Services Committee

Alderman Gustafson made a motion, and it was seconded by Alderman Kenny approval of the December 19, 2022 Municipal Services Committee Meeting Minutes.

Upon voice vote, the MOTION CARRIED UNANIMOUSLY 3-0.

DIRECTOR'S REPORT

Mr. Dan Gombac, Director provided an update on the Plainfield and Cass sign. He reported that staff is working with the attorneys and the final easement agreement and also who and how to maintain landscaping.

Mr. Gombac reported that the architect will be providing a rendering and that staff will work with the vendor to replace the sign.

There was discussion regarding the present signs and maintenance to get those updated. Mr. Gombac reported that he did not foresee this as a huge expense but that he anticipates labor costs to take them apart. He reported that each will be addressed as individual projects.

NEXT SCHEDULED MEETING

Chairperson Belczak announced that the next meeting is scheduled for Monday, March 27, 2022.

ADJOURNMENT

With no further business before the Committee, Alderman Kenny made a motion, and it was seconded by Alderman Belczak to adjourn. Upon voice vote, THE MOTION CARRIED unanimously, and the meeting adjourned at 7:30 p.m.

RESPECTFULLY SUBMITTED:

Thomas Belczak
Chairman

Eric Gustafson
Alderman

Joseph Kenny
Alderman