

AGENDA
Municipal Services Committee
March 28, 2016

- 1. Call to Order & Roll Call**
- 2. Establishment of Quorum**
- 3. New Business**
 - a. **Liquor Code Amendment**: Consideration of amending the Liquor Code to eliminate open, unused liquor licenses
 - b. **PZC 2015-20: 8433 Bailey Road, Society of Mount Carmel – Society of the Little Flower – National Shrine to St. Therese**: Petitioner requests approval of a final plat of subdivision and a major amendment to an approved PUD, including but not limited to: a new shrine chapel, reconstruction of parking lots and an additional parking lot, a new driveway onto N. Frontage Road and new pedestrian connections and plaza
 - c. **Resolution** – Approval of a resolution awarding a contract extension to Illinois Central Sweeping for the City of Darien’s Annual Street Sweeping Program not to exceed \$34,275.00
 - d. **Resolution** – Approval of a resolution awarding a contract extension to Rag’s Electric for the Annual 2016/17 Street Light Maintenance.
 - e. **Resolution** – Approval of a resolution to accept a proposal from Lake Shore Lighting for the purchase of LED Street Light Heads at a cost not to exceed \$187,160.00 as they relate to the City’s LED Streetlight Retrofit Project
 - f. **Resolution** – Approval of a resolution to accept the revised unit pricing from Rags Electric in an amount not to exceed \$55,680.00 for the removal of the existing street light heads and the installation of the new LED fixtures as they relate to the City’s LED Streetlight Retrofit Project
 - g. **Ordinance** – Approval of an ordinance authorizing the disposal of surplus property
 - h. **Minutes** – March 7, 2016 Municipal Services Committee
- 4. Director’s Report**
- 5. Next scheduled meeting –April 25, 2016**
- 6. Adjournment**

**AGENDA MEMO
MUNICIPAL SERVICES COMMITTEE
MEETING DATE: March 28, 2016**

Issue Statement

Liquor Code Amendment: Consideration of amending the Liquor Code to eliminate open, unused liquor licenses.

General Information

The Liquor Code, Section 3-3 of the City Code, establishes liquor license classifications Class A – O and provides a specific number of licenses for each classification. Currently, one Class A, one Class D and one Class M license are open, unused.

Staff recommends amending the Liquor Code to eliminate one license from each the Class A, Class D and Class M license classes:

Class	# provided by Code	Proposed
A	11	10
D	9	8
M	1	0

In the future, the City Council can amend the Liquor Code increasing the licenses available for a particular classification.

Attached is a list of liquor licenses as of February 19, 2016.

Staff Findings/Recommendations

Staff recommends the Municipal Services Committee make a motion recommending the Liquor Code be amended to eliminate the open, unused liquor licenses for the Class A, Class D and Class M.

Decision Mode

Municipal Services Committee: March 28, 2016

<i>fye 16 Business Name</i>	<i>Street #</i>	<i>Street Name</i>	<i>Amount</i>	<i>Total Amount with Video Terminals</i>	<i>Class License</i>
Aldi, Inc #80	2251	75th Street	\$1,500.00	\$1,500.00	A
Brookhaven Marketplace	7516	Cass Avenue	\$1,500.00	\$1,500.00	A
CVS Pharmacy #8501	8325	Lemont Road	\$1,500.00	\$1,500.00	A
Darien Liquor	8125	Cass Avenue	\$1,500.00	\$1,500.00	A
Jewel Food Store # 3123	7335	Cass Avenue	\$1,500.00	\$1,500.00	A
OPEN (Heritage Liquor)			50.00	50.00	A
Osco Drug Store # 3123	7329	Cass Avenue	\$1,500.00	\$1,500.00	A
Veet Tobacco Wine & Liquor	7516	Cass Avenue, #5A	\$1,500.00	\$1,500.00	A
Walgreens #06176	8300	Lemont Road	\$1,500.00	\$1,500.00	A
Walgreens #09033	7516	Cass Avenue	\$1,500.00	\$1,500.00	A
Wal-Mart #2215	2189	75th Street	\$1,500.00	\$1,500.00	A
Alpine Banquets, Inc.	8230	Cass Avenue	\$2,000.00	\$2,000.00	B
Carriage Way West	8700	Carriage Greens Drive	\$2,000.00	\$2,000.00	C
Aodake	2129	75th Street	\$2,000.00	\$2,000.00	D
Dotty's	7516	Cass Avenue, #24	\$2,000.00	\$2,125.00	D
La Notte Due	8123	Cass Avenue	\$2,000.00	\$2,075.00	D
Mi Hacienda	2601	75th Street	\$2,000.00	\$2,000.00	D
Old Vilnius Café	2601	75th Street	\$2,000.00	\$2,000.00	D
Open (Estilo Rancho Restaurant)			50.00	50.00	D
Patio Restaurant of Darien, Inc.	7440	Kingery Highway	\$2,000.00	\$2,000.00	D
Tai San Chef	2813	83rd Street	\$2,000.00	\$2,000.00	D
TGI Friday's Inc.	2201	75th Street	\$2,000.00	\$2,000.00	D
Circle K #6713	8975	Lemont Road	\$1,500.00	\$1,500.00	E

closed as of 3/20/16

Darien Pantry	737	Plainfield Road	\$1,500.00	\$1,500.00	E
Speedway #1425	10250	Lemont Road	\$1,500.00	\$1,500.00	E
Speedway #5344	8301	Lemont Road	\$1,500.00	\$1,500.00	E
Speedway #7765	7502	Cass Ave	\$1,500.00	\$1,500.00	E
Chuck E. Cheese	7409	Cass Avenue	\$1,500.00	\$1,500.00	F
Dry Dock	1125	North Frontage Road	\$2,000.00	\$2,125.00	G
Home Run Inn Corp.	7521	Lemont Road	\$2,500.00	\$2,500.00	H
Zazzo's Pizza and Catering	7360	Route 83	\$2,500.00	\$2,625.00	H
Q Bar	8109-8115	Cass Avenue	\$2,500.00	\$2,625.00	I
Buona	7417	Cass Avenue	\$1,500.00	\$1,500.00	K
Café Smilga	2819	83rd Street	\$1,500.00	\$1,500.00	K
Para Sushi and Ramen	2425	75th Street	\$1,500.00	\$1,500.00	K
Red Bowl Hibachi Grill & Sushi Buffet	7511	Lemont Rd.	\$1,500.00	\$1,500.00	K
Stella's Place	2415	75th Street, Unit C2	\$1,500.00	\$1,625.00	K
OPEN (VFW)			\$0.00	\$0.00	M
Miskatonic Brewing Company-License has not been issued yet	1000	N. Frontage Rd, Unit C	\$2,000.00	\$2,000.00	N
Chuck's Southern Comforts Café and Banquets, Inc.	8025	Cass Avenue	\$2,500.00	\$2,625.00	O
			\$65,500.00	\$66,325.00	

AGENDA MEMO
MUNICIPAL SERVICES COMMITTEE
MEETING DATE: March 28, 2016

Issue Statement

PZC 2015-20: 8433 Bailey Road, Society of Mount Carmel – Society of the Little Flower – National Shrine to St. Therese: Petitioner requests approval of a final plat of subdivision and a major amendment to an approved PUD, including but not limited to: a new shrine chapel, reconstruction of parking lots and an additional parking lot, a new drive-way onto N. Frontage Road and new pedestrian connections and plaza.

General Information

Petitioner: The AT Group
7 N. Wisner Street
Park Ridge, IL 60068

Property owner: Society of Mount Carmel
1313 N. Frontage Road
Darien, IL 60561

Property Location: 8433 Bailey Road

PIN: 09-33-401-012; -013; -010

Existing Zoning: R-3 Multi-Family Residence

Existing Land Use: Religious institution

Comprehensive Plan Update: Institutional

Surrounding Zoning and Land Use:
North: R-2 Single-Family Residence: single-family homes
East: R-1 Single-Family Residence: Cass Avenue/I-55 interchange
South: O Office and R-1 Single-Family Residence: office and Cass Avenue/I-55 interchange
West: R-2 Single-Family Residence and R-3 Multi-Family Residence: park, junior high school, single-family homes

Size of Property: 38 acres

Floodplain: None

Natural Features: Property contains a lake and wetlands.

Transportation: Property has frontage on Bailey Road and N. Frontage Road, with access off of Bailey Road.

History: In 1977, the property was annexed into the City of Darien, the City Council approved a special use for a PUD to include: a church and similar places of worship, retreat and conference center, nursing home or similar use, and residential.

Documents Submitted

This report is based on the following information submitted to the Community Development Department by the Petitioner:

1. Written project summary, 1 sheet.
2. Topographic Survey, 1 sheet, prepared by Jacob & Hefner Associates, Inc., dated August 22, 2011.
3. Site Plan, Existing Conditions, 1 sheet, prepared by Engineering Enterprises, Inc., dated December, 2015.
4. Site Plan, Overall Site Plan, 1 sheet, prepared by Engineering Enterprises, Inc., dated December, 2015.
5. Landscape Plan, 5 sheets, prepared by LandTech Design, Ltd., dated December 14, 2015.
6. Exterior Building Drawing and Floor Plan, Chapel, 3 sheets, prepared by Charles Vincent George Architects, dated December 15, 2015.
7. Signage, 5 sheets, prepared by Olympic Signs, dated June 25, 2015.
8. Photometric Plan, 1 sheet, prepared by Charles Vincent George Architects, dated December 15, 2015.
9. Improvement Plan, 15 sheets, prepared by Engineering Enterprises, Inc., dated December 14, 2015.
10. Final Plat of Subdivision, 1 sheet, prepared by Engineering Enterprises, Inc., dated December, 2015.

Planning Overview/Discussion

The subject property is located at the northeast corner of N. Frontage Road and Bailey Road. The National Shrine campus includes a spiritual center, chapel and museum. The spiritual center relocated to the former housing for the elderly, the old spiritual center was demolished in 2015.

The petitioner provided a written summary of the proposed plan for the campus. The centerpiece of the plan is a new, 15,000 square foot, 650-seat chapel. The significant changes to the campus plan occur well within the campus boundary.

The site plan needs to include dimensions for parking stalls, drive aisle widths, driveway widths, distance between driveways along Bailey Road, building foundations, for example.

Parking and Driveway Entrances

The plan provides 253 parking stalls, which includes 10 handicapped accessible stalls. Additional parking, not included in this figure, is located to the north of the spiritual center. It appears adequate

parking is being provided, however, the petitioner should describe how the various campus activities fluctuate throughout a typical day, i.e. peak parking demand times.

The parking lot between the spiritual center and museum will be reconstructed, the parking lot to the east of the museum will be reconstructed and expanded. Along Bailey Road, the existing parking setback will be maintained as currently exists with the parking lot to the north of the spiritual center. No issue with the parking setback from N. Frontage Road.

Driveways off of Bailey Road will be realigned so they are perpendicular to Bailey Road, the south driveway entrance will be relocated to align opposite Willow Creek Lane. The new driveway entrance off of N. Frontage Road requires approval from the Illinois Department of Transportation (IDOT) since IDOT has jurisdiction over N. Frontage Road.

Signage

The plan includes new signs along Bailey Road, in some cases replacing existing signs. Signs include ground and directional signs. While staff does not object to the proposed signage, one ground sign is 48 square feet (Sign Code limits signs for religious institutions to 32 square feet), and the direction signs are 6 square feet and 15 square feet, both 7 feet tall (Sign Code limits directional signs to 4 square feet and 4 feet tall).

Two signs are shown to be located within the Bailey Road right-of-way. All signs are required to be located outside of a road right-of-way, at least 4 feet from the right-of-way and 20 feet from a driveway.

The sign drawing, page 1, notes “two lines of 6 inch zip change”. The petitioner needs to clarify “zip change”.

Ground signs are required to have bases which are at least 75% of the sign width with a maximum vertical clearance of 3 feet between the adjacent grade and bottom of the sign. These dimensions need to be shown on the sign drawings.

Photometric Plan

The photometric plan indicates parking lot illumination level complies.

Landscape Plan

The landscape plan provides landscaping around the perimeter of the reconstructed parking lot and new parking lot and within landscape islands. As a whole, the campus includes existing trees and other landscape features meeting the intent of the Zoning Ordinance.

Building Elevations (New Chapel) and Tower

The exterior building materials for the new chapel include: face brick, masonry veneer, art glass windows, metal panel canopy, metal panels, metal columns, metal coping, storefront entry system,

aluminum door and frame.

Within the R-3 zoning district, the maximum building height is 3 stores not to exceed 35 feet. The building height is measured to the highest elevation of the roof in the case of a slant or flat roof, at the center of the building front. The top the roof is 31 feet, top of parapet is 47'-9", with a metal cross on the roof extending to 68'-4".

The plan includes a plaza with a tower. The tower will have a masonry veneer with a metal cross on top. The tower height is 48'-6", with the top of the cross at 68'-1".

Section 5A-5-12 of the Zoning Ordinance permits ornamental towers, spires, steeples, false mansards, parapet walls and similar structures to be erected to their customary height, regardless of the height limitations of the zoning district in which they are located.

Plat of Subdivision

The campus contains several parcels. The petitioner proposes creating one lot of record to cover the entire campus to eliminate lot lines between campus uses.

Engineering and Fire District

City Engineer's comments are noted in a letter dated January 28, 2016.

The Darien-Woodridge Fire Protection District provided their comments in a letter.

Staff Findings/Recommendations

Staff does not object to the proposed campus alterations. The proposed alterations do not change the use or character of the previously approved PUD plan. The plat of subdivision cleans up the various parcel and lot lines, creating one lot of record for the entire campus. The new driveway off of N. Frontage Road will ease traffic movements along Bailey Road and will provide emergency vehicles another entrance. The new chapel, plaza and tower will greatly enhance the campus.

Therefore, staff recommends the Planning and Zoning Commission make the following motion recommending approval of the petitions:

Based upon the submitted petition and the information presented, the request associated with PZC 2015-20 is in conformance with the standards of the Darien City Code and, therefore, I move the Planning and Zoning Commission recommend approval of the petitions, subject to the following:

- 1. Dimensions on site plan.**
- 2. Sign locations to comply with the Sign Code.**
- 3. The following waivers from the Sign Code:**
 - a. To increase the permitted ground sign area for a religious institution from 32 to 48 square feet.**

- b. **To increase the permitted directional sign area from 4 square feet to 6 square feet and 15 square feet.**
- c. **To increase the permitted directional sign height from 4 feet to 7 feet.**
- 4. **Address comments in the letter from Dan Lynch, City Engineer, dated January 28, 2016.**
- 5. **Address comments in the letter from the Darien-Woodridge Fire Protection District.**

Planning and Zoning Commission Review – February 3, 2016

The Planning and Zoning Commission considered this matter at their February 3, 2016, meeting. The following members were present: Beverly Meyer – Chairperson, Robert Cortez, Andrew Kelly, Louis Mallers, Raymond Mielkus, Kenneth Ritzert, Michael Griffith – Senior Planner and Elizabeth Lahey – Secretary.

Absent: Ronald Kiefer, John Laratta

Michael Griffith, Senior Planner, reviewed the agenda memo. He summarized the campus alterations, noted the property contains wetlands that require County review, noted the proposed driveway off of N. Frontage Road required IDOT approval. He noted there are engineering comments to be addressed but the comments were not a major obstacle.

Father Colaresi, the petitioner, provided the Commission with a letter describing the history of the campus.

Commissioner Mallers asked if the existing chapel will remain.

Father Colaresi stated no, that space will become part of the visitor center/museum.

Commissioner Ritzert asked about the walkways.

Father Colaresi stated the walkways will meander to create a quiet, reflective space.

Andrea Dolter, Charles Vincent George Architects, the petitioner’s architect, described the proposed plan in more detail. She stated the walkways will connect the various campus buildings, stating there will be minor alterations to the spiritual center and museum related to new entrances. She went over the new chapel, noted the exterior building materials to include brick, stone, metal panels and stained glass windows. She stated the mechanical equipment will be located behind the chapel, screened by a masonry wall.

Chairperson Meyer asked about stormwater drainage.

Bruce Aderman, Engineering Enterprises, Inc., the petitioner’s engineer, stated stormwater will be

directed to the existing pond, stating the pond water level will be lower to provide the additional stormwater storage volume. He stated at the moment there is no real detention provided.

Chairperson Meyer asked if a traffic study had been done concerning the driveway coming off N. Frontage Road.

Mr. Aderman stated no, but that they have meet with IDOT to determine requirements. He stated the driveway off N. Frontage Road will be right-in/right-out, a deceleration lane provided on the Frontage Road to allow drivers to turn into the campus. He stated the driveway off N. Frontage Road is long so there should not be a problem with vehicles stacking onto the road. He stated the driveways off Bailey Road are full access, that they are being realigned.

Chairperson Meyer asked about the tower height related to planes.

Ms. Dolter stated the tower height is not tall enough to cause a problem.

The Commission discussed signage, noting the requested waivers from the Sign Code. Father Colaresi stated one ground sign will include an electronic message board sign, the “zip change”.

Mr. Griffith stated an electronic message board sign requires a waiver from the Sign Code which can be added to the petition.

No one from the public offered comments.

Without further discussion, Commissioner Mallers made the following motion, seconded by Commissioner Mielkus,

Based upon the submitted petition and the information presented, the request associated with PZC 2015-20 is in conformance with the standards of the Darien City Code and, therefore, I move the Planning and Zoning Commission recommend approval of the petitions, subject to the following:

- 1. Dimensions on site plan.**
- 2. Sign locations to comply with the Sign Code.**
- 3. The following waivers from the Sign Code:**
 - a. To increase the permitted ground sign area for a religious institution from 32 to 48 square feet.**
 - b. To increase the permitted directional sign area from 4 square feet to 6 square feet and 15 square feet.**
 - c. To increase the permitted directional sign height from 4 feet to 7 feet.**
 - d. To permit an electronic message board sign on the 48 square foot**

ground sign.

4. **Address comments in the letter from Dan Lynch, City Engineer, dated January 28, 2016.**
5. **Address comments in the letter from the Darien-Woodridge Fire Protection District.**

**Upon a roll call vote, THE MOTION CARRIED by a vote of 6-0.
(Commissioners Kiefer and Laratta were absent.)**

Municipal Services Committee – March 28, 2016

Since the Planning and Zoning Commission, the petitioner submitted revised plans to address comments. Plans have been reviewed. Major comments have been addressed.

Based on the Planning and Zoning Commission’s recommendation, staff recommends the Committee make the following recommendation to approve the petitions subject to conditions:

Based upon the submitted petition and the information presented, the request associated with PZC 2015-20 is in conformance with the standards of the Darien City Code and, therefore, I move the Municipal Services Committee recommend approval of the petitions, subject to the following:

1. **Dimensions on site plan.**
2. **Sign locations to comply with the Sign Code.**
3. **The following waivers from the Sign Code:**
 - a. **To increase the permitted ground sign area for a religious institution from 32 to 48 square feet.**
 - b. **To increase the permitted directional sign area from 4 square feet to 6 square feet and 15 square feet.**
 - c. **To increase the permitted directional sign height from 4 feet to 7 feet.**
 - d. **To permit an electronic message board sign on the 48 square foot ground sign.**
4. **Address comments in the letter from Dan Lynch, City Engineer, dated March 18, 2016.**
5. **Address comments in the letter from the Darien-Woodridge Fire Protection District, dated February 12, 2016.**

Decision Mode

Planning and Zoning Commission: February 3, 2016
Municipal Services Committee: March 28, 2016



National Shrine Campus →

Map data © OpenStreetMap contributors, Imagery © Mapbox
DuPage County
Emergency Department
2020-08-10
121 W. County Road, N.
Naperville, IL 60563
630-407-4800
www.dpcog.org

**Society of Mt. Carmel
Society of the Little Flower -- National Shrine to St. Therese
Project Summary**

The Society of Mount Carmel through its development arm, the Society of the Flower, is planning a redevelopment of the National Shrine to St. Therese. The National Shrine campus is composed of three buildings; the Shrine Museum/Gift Shop, the Carmelite Spiritual Center, and the Shrine Chapel. A new 15,000 Shrine Chapel will be the center piece for the redevelopment of the 40 acre Shrine site. The new Chapel will replace an existing smaller chapel that is now part of the Shrine Museum. The Chapel will be constructed on land which was the site of the former Carmelite Spiritual Center building. The Center was demolished this past summer after its operations were move into the former Carmelite Carefree Village.

Critical to the development of the new Chapel is the creation of a more cohesive campus environment by adding pedestrian connections to the current Museum and Spiritual Center. The current facilities will retain their present uses but will undergo modest renovations to provide new entrances, access ramps, mechanical screening and similar improvements that will allow easier access to and among buildings and tie the buildings together architecturally.

The Shrine chapel will be located in the same general areas as the former Carmelite Spiritual Center building. It will be the primary worship space for the Shrine, designed to hold a maximum of 650 people at a single service. The floor plan also provides for smaller multi-use spaces that can be partitioned off and used for general instruction, retreats and prayer services for smaller groups. No changes to the current uses on the site are anticipated. The use of the new Shrine chapel will be consistent with programs that were held at the former chapel. The Shrine will maintain its current hours of operation, open every day from 10 a.m. to 4 p.m. Daily mass will be celebrated, private tours of the shrine/museum will be offered, and special guided day tours or overnight stays will be provided for larger group pilgrimages. The Shrine campus will continue to host retreats and day programs as well as providing lodging and meals to Shrine guests. Special seasonal events will also continue to be held at the site, most notable being the Christmas Celebration, the Lenten Stations of the Cross, Our Lady of Mount Carmel Feast Day and St. Therese's Feast Day Celebration.

Included as part of the development program are the reconstruction of the current parking lots and additional parking areas to serve the new Shrine chapel and the Museum; an expanded bus drop-off, loading and parking areas; a right-in, right-out access drive off the Frontage road to help reduce traffic on Bailey road; new monument signs; wetlands enhancements and improved storm water management; and lake edge restoration with an expanded pathway network that will provide contemplative areas for visitors to the Shrine.

Start of construction for the chapel, parking and the required site improvements is currently scheduled for late spring of 2016 with completion anticipated in the summer of 2017. Due to budget constraints, certain elements of the development program may be phased and constructed at a later date. The two principal items which the Society is considering as a potential future phases are the clock tower with the colonnade walk and the new frontage road access drive.

New National Shrine of St. Thérèse

August, 2015

Darien, Illinois

The Carmelites have been in Darien, on a campus called “Aylesford” since 1959 – originally owning 50 acres. It was intended to be a place of prayer, reflection and spiritual growth in the Roman Catholic and Carmelite tradition.

Early on, the “stables” of the previous farm had been partially turned into a Chapel for Mass and prayer services, dedicated to Mary, Star of the Sea. Eventually it was moved into the “white house,” the Carmelite residence.

Once the Retreat House, St. Paul’s Hall and Scapular Center were developed, we opened a Senior Residence in 1978, Carmelite Carefree Village. We expanded the Carmelite Spiritual Center in 1979, to accommodate more retreat people. The Carmelites were making Darien our “centering place.”

In 1984 the Society of the Little Flower, the development arm of the Carmelites, moved to Darien from the south side of Chicago. Once that move was made, plans were set to build a new National Shrine to St. Thérèse here, to replace the one on the south side of Chicago that had burned in 1975, and was somewhat abandoned because of the change in demographics. Through the generosity of a lay Carmelite and other donors, this new National Shrine was built and dedicated in 1987. We limited its size by the amount of the gift we had received, to remain within budget.

In the early 1990’s our Provincial offices moved onto this Campus, the Old Cass School building. More and more people came and we learned quickly that we could not accommodate the crowds that were coming, even to the daily 11:30 Shrine Mass each weekday. In October 1999, we hosted the visit of the Relics of St. Thérèse here at the Shrine – 50,000 people came in three days, even causing some alarm to the local police. We learned that St. Thérèse is a celebrity within the Catholic community beyond our imagining.

So we started to expand the National Shrine – doubling the seating capacity of the Shrine Chapel from 87 to 200 chairs. It was dedicated in February 2002. Gradually the daily crowds kept coming and growing – and often the 200 chairs could not accommodate the number of people who came to Mass each day. Many times, on feast day, it was way over-crowded. We also started offering special events to attract larger crowds and the response was great. We even started using OLMC Church on the other side of our campus to accommodate the large crowds. But we were limited by what they had already scheduled and certainly could not do these on weekends when parish Masses prohibited other uses.

So dreams emerged about building a larger Shrine to accommodate the people who were actually coming. These dreams included an expanded retreat house, better use of the open lot near to Carefree Village, and diminishing numbers at the dated Carmelite Carefree Village. In 2012, we developed the open lot into the Carmelite Meditation

Garden, to become a place of reflection and prayer, including the 14 Stations of the Cross, a beautiful gazebo, benches and water feature.

These expansion possibilities came to a head when we had to close Carmelite Carefree Village in May 2014 because of declining resident numbers and the huge financial loss we were experiencing. Heaven has a way of opening new doors. In August 2014, a generous donor with a large Foundation wanted to help us and fund the building of a New National Shrine for St. Thérèse.

That set the wheels in motion. We decided to renovate the Carmelite Carefree Village building to become the new Carmelite Spiritual Center – it now had three times the space and rooms for retreatants. We moved in there in the Spring of 2015. In the Fall of 2015, we demolished the old Spiritual Center, to make room for the new Shrine building.

In the Fall of 2015, we hired an Architect, Construction Company and Project Manger to create a wonderful new Shrine, as well as connect the campus better and make it an inviting place of prayer, spiritual growth and programs. We are trying to work through the myriad permits, regulations and water issues that are arising.

The Carmelite Campus in Darien includes:

Carmelite Provincial Offices
Society of the Little Flower
Carmelite Provincial Archives
National Museum and Shrine of St. Thérèse
Lay Carmelite National Headquarters
Carmelite Religious Gift Shop
Carmelite Media/Communications Office
Carmelite Mission Office
Carmelite Spiritual Center
Our Lady of Mount Carmel Parish
Carmelite Meditation Garden
Four Carmelite Residences
 White house
 Farm House
 Winterberry House
 Brandsma Carmelite Retirement Home



January 2016 addendum: I have an immediate concern that that regulations, permits and water issues are taking up a lot of time and adding more to the overall cost of this project. The Foundation is expressing impatience as to why we haven't started building this New Shrine. We don't want to lose this gift and very generous donation, and need to stay within the budget of this gift.

Fr. Bob Colaresi, O. Carm.

Visitors to Carmelite Campus – August 2015

Evidence shows that the Carmelite Campus in Darien, Illinois receives between 55,000 and 60,000 visitors a year. This includes the National Shrine of St. Thérèse, the Carmelite Visitors Center and Gift Shop, and the Carmelite Spiritual Center.

The Breakdown is as follows:

- **48,000 – at the 11:30 Shrine Mass – we have public Mass every Monday through Friday at 11:30, with an average attendance of 200 people for the 240 week day public Masses.**
- **2,000 – 3,000 people come to large Feast Day celebrations like the St. Thérèse Feast Day and other special events which attract 750 to 1,000 pilgrims each time.**
- **Pilgrimage Bus Tours of the Shrine bring in about 500 people a year for day programs.**
- **Individuals and families who come to the Shrine for private devotion or to visit St. Thérèse's museum are at least 2,000 people a year.**
- **The Carmelite Spiritual Center hosts over 5,000 people a year on programs that are daily, week long, or weekends.**

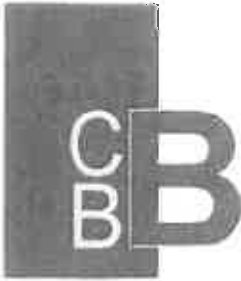

CHRISTOPHER B. BURKE ENGINEERING, LTD.

9575 West Higgins Road Suite 600 Rosemont, Illinois 60018 TEL (847) 823-0500 FAX (847) 823-0520

March 18, 2016

City of Darien
1702 Plainfield Road
Darien, IL 60561

Attention: Mike Griffith

Subject: National Shrine of Saint Therese – Improvement Plans
(CBBEL Project No. 950323H177)

Dear Mike:

As requested, we have reviewed revised the Improvement Plans and supporting documents for the aforementioned property. The following comments are submitted for your consideration:

TOPOGRAPHIC SURVEY

The following comments pertain to the Topographic Survey prepared by Jacob & Hefner Associates, Inc. and bearing a revision date of February 16, 2016:

No Comments.

PHOTOMETRIC PLAN

1. The City encourages (but does not mandate) the use of LED fixtures.

PLAT OF SUBDIVISION

The following comments pertain to the Plat of Subdivision prepared by Engineering Enterprises, Inc. and dated February, 2016:

1. Please revise the "Storm Water Management Easement" to read "Stormwater Drainage and Detention Easement" over the detention basin.

IMPROVEMENT PLAN

The following comments pertain to the Final Engineering Plan prepared by Engineering Enterprises, Inc. and bearing a revision date of February 17, 2016:

Sheet 1 of 27 -- Cover Sheet

1. Section 15-33 of the DuPage County Storm Water Ordinance provides that the topography be on NAVD 88 datum and meet certain standards. Currently the cover

page reads elevations are based on NAVD 1998. We presume this is a typographical error.

Sheet 2 of 27 – Construction Specifications and Notes

1. Revise Note 15 of the General and Construction Specifications to clean pavement immediately.

Sheet 3 of 27 – Construction Specifications and Notes

No Comments.

Sheet 4 of 27 – Typical Sections – Frontage Road

No Comments.

Sheet 5 of 27 – Existing Conditions

No Comments.

Sheet 6 of 27 – Overall Site Plan

No Comments.

Sheet 7 of 27 – Erosion and Sediment Control

1. Provide silt fence around the downslope of the disturbed area. Additional areas would include south of the improvements east of the Visitor's Center.

Sheet 8 of 27 – Stormwater Pollution Prevention Plan

No Comments.

Sheet 9 of 27 – Stormwater Pollution Prevention Plan Details

No Comments.

Sheet 10 of 27 – Stormwater Pollution Prevention Plan Details

No Comments.

Sheet 11 of 27 – Site Plan

No Comments.

Sheet 12 of 27 – Utility Plan

1. For each utility conflict, specify how the watermain protection is achieved.

Sheet 13 of 27 – Sanitary Sewer Plan & Profile

No Comments.

Sheet 14 of 27 – Grading Plan – 01 (East)

1. Remove the existing 24" CMP outfall as a new outfall is proposed with attenuated release rates through the proposed restrictor orifice. *It is understood the existing 24" CMP discharges to an existing wetland and will remain in place.*

Sheet 15 of 27 – Grading Plan – 02

No Comments.

Sheet 16 of 27 – Grading Plan – 03

1. The handicap parking stalls adjacent to the Visitor's Center have a slope greater than 2.0% (approximately 6%).
2. Verify with Public Services prior to relocation of any parkway tree.

Sheet 17 of 27 – Grading Plan – 04

No Comments.

Sheet 18 of 27 – Grading Plan – 05

No Comments.

Sheet 19 of 27 – North Frontage Road Plan and Profile

No Comments.

Sheet 20 of 27 – North Frontage Road Geometric, Striping and Signage Plan

No Comments.

Sheet 21 and 22 of 27– Typical Details

1. Provide a detail for the stamped concrete.

Sheet 23 - 27 of 27– Highway Standards

No Comments.

General Comments

1. Provide a plan set for the proposed pedestrian bridges. *It is understood pedestrian bridges are not fully engineered at this time and detailed plans will be provided prior to installation.*
2. Provide the emergency overflow route locations for each detention basin and rain garden. Also provide a cross-sectional detail of each emergency overflow weir.
3. Label all of the proposed detention basin including the existing basins and rain gardens and include the stormwater storage volume in ac-ft.
4. A permit from IDOT will be required to work in the North Frontage Road right-of-way.
5. The sanitary sewer shall be reviewed and approved by the DuPage County Public Works.
6. Verify if IEPA permits are required for the watermain.
7. An IEPA NPDES permit is required and a copy of the SWPPP must be submitted to the City.
8. Verify with the fire protection district that the proposed parking lot will accommodate their fire protection equipment and that the locations of the fire hydrants and building connections are acceptable.

CONSTRUCTION LOGISTICS PLAN

1. Construction fence should be also included along the east side of the disturbed area along the silt fence adjacent to the existing detention basin.

STORM WATER MANAGEMENT REPORT & DUPAGE COUNTY STORMWATER PERMIT APPLICATION, REVISED FEBRUARY 22, 2016

General Comments

1. Review will be required by DuPage County for impacts and mitigation to the wetland. The tabs in the stormwater submittal should be numbered as detailed in the flow chart found on the County website. References in the following comments that reference a tab, refer to the numbered tab from the flow chart.
2. Verify the offsite tributary areas on the Existing Drainage Plan Exhibit. It appears there is an offsite tributary area north of the property.
3. The proposed tributary area calculations do not show subarea 6.1 and 6.2, only area 6 is shown. Also show subarea 6.1 and 6.2 on the Proposed Drainage Plan.
4. Provide the total impervious and pervious areas on the Impervious Area Plan Exhibit.
5. In the Proposed Storm Sewer Tributary Areas Plan, provide the total tributary areas for each proposed storm sewer in acres.
6. Please provide the storm sewer calculations for the existing storm sewer along the west side of the property.

7. Some of the rim and invert elevations in the Hydraflow Calculations for the proposed storm sewer systems do not match the plan rim and invert elevations.
8. The south storm sewer system should have the most upstream ground elevation match the invert elevation of 711.00
9. Not all of the proposed storm sewers have the 10 - year HGL contained within the pipe.
10. Provide an exhibit that clearly shows the flow lengths for each subarea in the stormwater runoff model for both existing and proposed conditions.
11. In the stormwater runoff model proposed calculations for Pond 3E, revise the statement to lower the water surface elevation by 9 inches.
12. Show the locations for the channel ponds (Pond 5 and 6).
13. Show the 100 - year HGL for the proposed channel, also provide a cross-section where the pedestrian bridge crosses.
14. Provide an engineer's estimate to establish a letter of credit as required per Section 15-54.8 of the DuPage County Stormwater Ordinance and as detailed in the City of Darien Subdivision Regulations.
15. Include the statement by the design engineer as required by Section 15-36 of the DuPage County Stormwater Ordinance.
16. Provide the signed statement by the land owner and developer as required in Section 15-47.A.3.

If you have any questions, please feel free to contact Martin Bojovic of this office.

Sincerely,

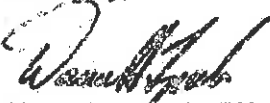

Daniel L. Lynch, PE, CFM
Head, Municipal Engineering Department

Cc: Dan Gombac – City of Darien



DARIEN-WOODRIDGE

Fire Protection District

7550 Lyman Avenue, Darien, Illinois 60561, (630) 910-2200 - Fax (630) 910-2203

February 12, 2016

City of Darien
Community Development
1702 Plainfield Road
Darien, IL 60561

RE: 8433 Bailey Road. Saint Therese Chapel

Gentlemen:

1. **A Fire Sprinkler/Alarm system will need to be installed as well as a Fire Sprinkler Standpipe System.**
A Fire Sprinkler/Alarm system is being installed along with a Fire Sprinkler Standpipe System. Plans are to be submitted at a later date.
2. **A Fire lane shall be established on the Southern side of the Shrine. (currently handicap parking)**
A Fire lane will be established on a portion of the existing fire lane.
3. **Fire hydrants shall be located along public streets, fire lanes, or access routes so that no portion of the building will be over 250 feet from a public fire hydrant. Where this is not possible, additional hydrants shall be located on the premises and be accessible to motorized fire apparatus.**
Fire Hydrant locations have been discussed and finalized.
4. **At least two (2) fire hydrants shall be located within 300 feet of the building.**
Two Hydrants are within the 300'.
5. **Hydrants shall not be located further than 75 feet from any fire department sprinkler or standpipe connection as determined by the code official.**
A Hydrant will be located within 75' of the FDC.
6. **Hydrants shall not be located closer than 25 feet to a building.**
No Hydrants are located within 25 of the building
7. **Access to fire hydrants shall be all-weather roadways adequate in width, clearance and strength for firefighting purposes. Such routes including private roadways shall be maintained accessible during all seasons of the year.**
Complied.
8. **The fire department connection shall be so located that fire apparatus and hose connected to supply the system will not obstruct access to the buildings for other fire apparatus. The location of fire department connections shall be approved by the fire chief.**
Complied.
9. **Fire apparatus access roads shall not exceed 10 percent in grade.**
Awaiting final plans showing the grade of the complex.
10. **The required minimum turning radius of a fire apparatus access road shall be 28' (inside)**
Complied.

Sincerely,

Lt. James Karasek, Director
Fire Prevention Bureau

7'-0"
6'-0"
5 3/4"
4'-0"
5 3/4"
5 3/4"
12"
8"

10'-0"
8'-2"



SIGN #1
ONE (1) D.F. LED ILLUM. MONUMENT DISPLAY 3/8" = 1'-0"
SIGN TO BE DURANODIC BRONZE. WHITE LEXAN FACES W/ 3M 230-89
DURANODIC VINYL COPY.



account representative: FWJ/R. client: SOCIETY OF MT CARMEL
1317 N. FRONTAGE RD. DARIEN, IL.

drawn by: Dan S. job #: 15-6067
6-25-15

Customer's Signature: _____ Date: _____

THIS IS AN UNFINISHED BUSINESS SUBMITTED BY CONSTRUCTION WITH A PROTECTIVE-AGE PLACEMENT FOR FINAL INFO IN 2015 BY THE CHURCH DEPARTMENT. EXHIBITS ARE PROVIDED TO SUPPORT OUTSIDE OF YOUR ORGANIZATION THROUGH THE COURTESY OF OLYMPIC SIGNS INC. ANYWHERE IN EXCLUSIVE PROPERTY OF OLYMPIC SIGNS INC.

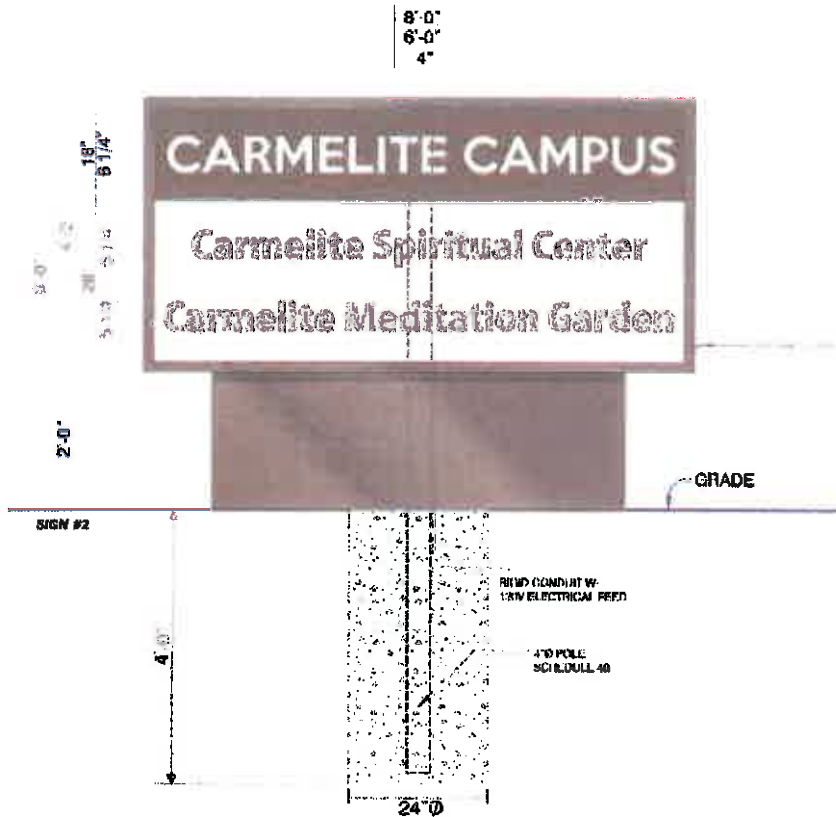

ONE (1) D.F. LED ILLUM. MONUMENT DISPLAY 1/2" = 1'-0"
SIGN TO BE ANODIZED DURANODIC BRONZE. WHITE LEXAN FACES W/ 3M 230-68 DURANODIC VINYL COPY



EXISTING



PROPOSED



account representative: **RWJR** client: **SOCIETY OF MT CARMEL**

1317 N. FRONTAGE RD. DARIEN, IL.

drawn by: **Dan S.**

job #: **15-6067**
 6-25-15
 rev.# **10-8-15**

Customer's Signature: _____

Date: _____

Comment: _____

WWW.OLYSIGNS.COM

THIS IS AN UNBIDDABLE, UNAPPROVED, UNLICENSED DESIGN IDENTIFIED BY OURSIGNED WITH A PROHIBIT USE AND PLANNING FIRM. THIS IS NOT TO BE COPIED, REPRODUCED OR OTHERWISE USED IN ANY MANNER WITHOUT THE WRITTEN PERMISSION OF OLYMPIC SIGNS, INC. ANY USE IS AT THE USER'S SOLE RISK.

page 2 of 5

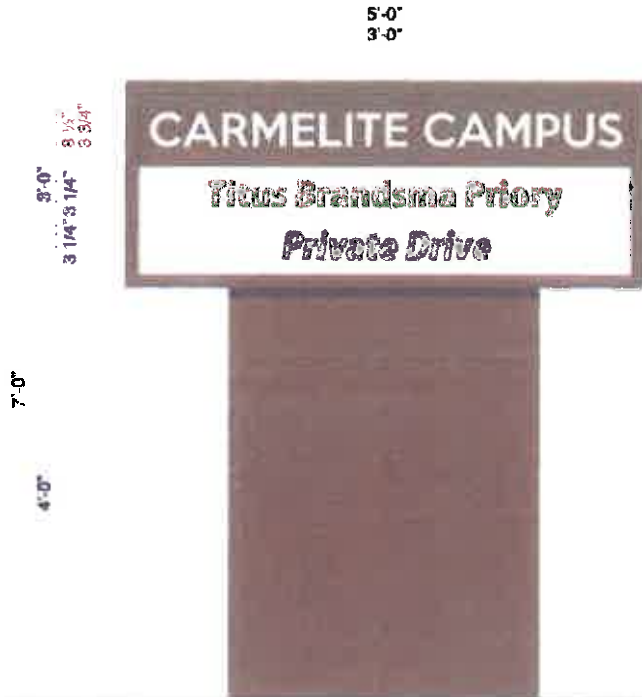

SIGN 03
ONE (1) D.F. LED ILLUM. MONUMENT DISPLAY 3/4" = 1'-0"
SIGN TO BE DURANODIC BRONZE. WHITE LEXAN FACES W/ 3M 230-69
DURANODIC VINYL COPY.

Customer's Signature: _____ Date: _____

OLYMPIC SIGNS SOCIETY OF MT CARMEL 1317 N. FRONTAGE RD. DARIEN, IL. www.OLYSIGNS.COM

630.424.6100 630.274.6121

THIS OLDSIGN SIGNAGE IS THE PROPERTY OF OLDSIGN CORPORATION. IT IS TO BE USED ONLY FOR THE PROJECT AND LOCATION SPECIFIED HEREON. ANY OTHER USE OR REUSE OF THIS SIGNAGE WITHOUT THE WRITTEN PERMISSION OF OLDSIGN CORPORATION IS PROHIBITED. THE USER ASSUMES ALL LIABILITY FOR THE USE OF THIS SIGNAGE. OLDSIGN CORPORATION IS NOT RESPONSIBLE FOR THE USE OF THIS SIGNAGE IN ANY MANNER. OLDSIGN CORPORATION IS NOT RESPONSIBLE FOR THE USE OF THIS SIGNAGE IN ANY MANNER. OLDSIGN CORPORATION IS NOT RESPONSIBLE FOR THE USE OF THIS SIGNAGE IN ANY MANNER.

page 3 of 5

5'-0"
3'-0"

8 3/4"
3 1/4"
5'-0"
1'-0"
7'-0"
1'-0"



SIGN #4
ONE (1) D.F. LED ILLUM. MONUMENT DISPLAY 3/4" = 1'-0"
 SIGN TO BE DURANODIC BRONZE. WHITE LEXAN FACES W/ 3M 230-69
 DURANODIC VINYL COPY.



EXISTING



PROPOSED

OLYMPIC SIGNS account representative: PMLJR client: SOCIETY OF MT CARMEL 1317 N. FRONTAGE RD. DARIEN, IL drawn by: Dan S. job#: 15-6087 6-25-16 REV. #

Customer's Signature: _____ Date: _____
 Comment: _____

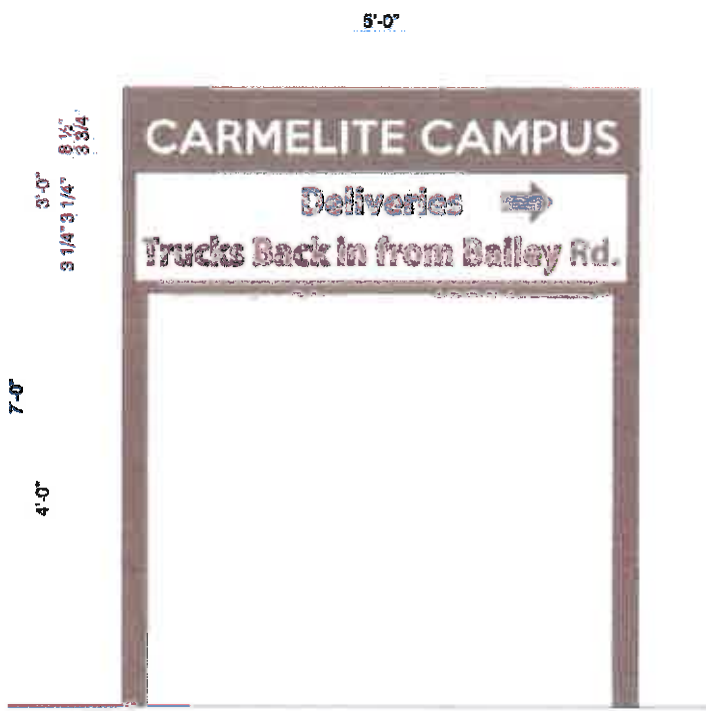

SIGN #5
ONE (1) S.E. NON-ILLUM. DIRECTIONAL DISPLAY 3/4" = 1'-0"
 SIGN TO BE DURANODIC BRONZE, WHITE & 3M 230-69
 DURANODIC VINYL COPY

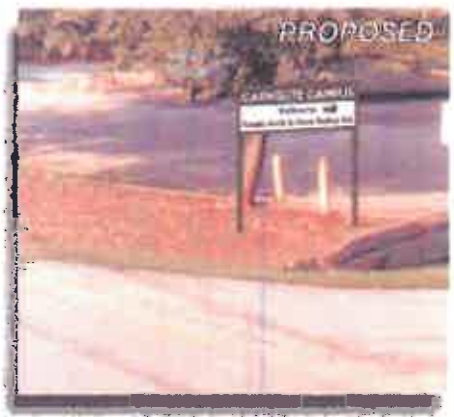

Customer's Signature: _____ Date: _____

OLYMPIC SIGNS 1100 N. Main Street, Dan S. 630-255-1111 www.olympic-signs.com

client: **SOCIETY OF MT CARMEL** 1317 N. FRONTAGE RD. DARIEN, IL. drawn by: Dan S. job#: 15-0067

THIS IS AN PRELIMINARY DRAWING SUBMITTED BY ARCHITECT FOR A PROPOSED PROJECT. IT IS NOT TO BE CONSIDERED A CONTRACT. ANY CHANGES OR ADDITIONS TO THIS DRAWING SHALL BE THE SOLE RESPONSIBILITY OF THE ARCHITECT. OLYMPIC SIGNS, INC. ACCEPTS NO LIABILITY FOR ANY ERRORS OR OMISSIONS. page 5 of 5

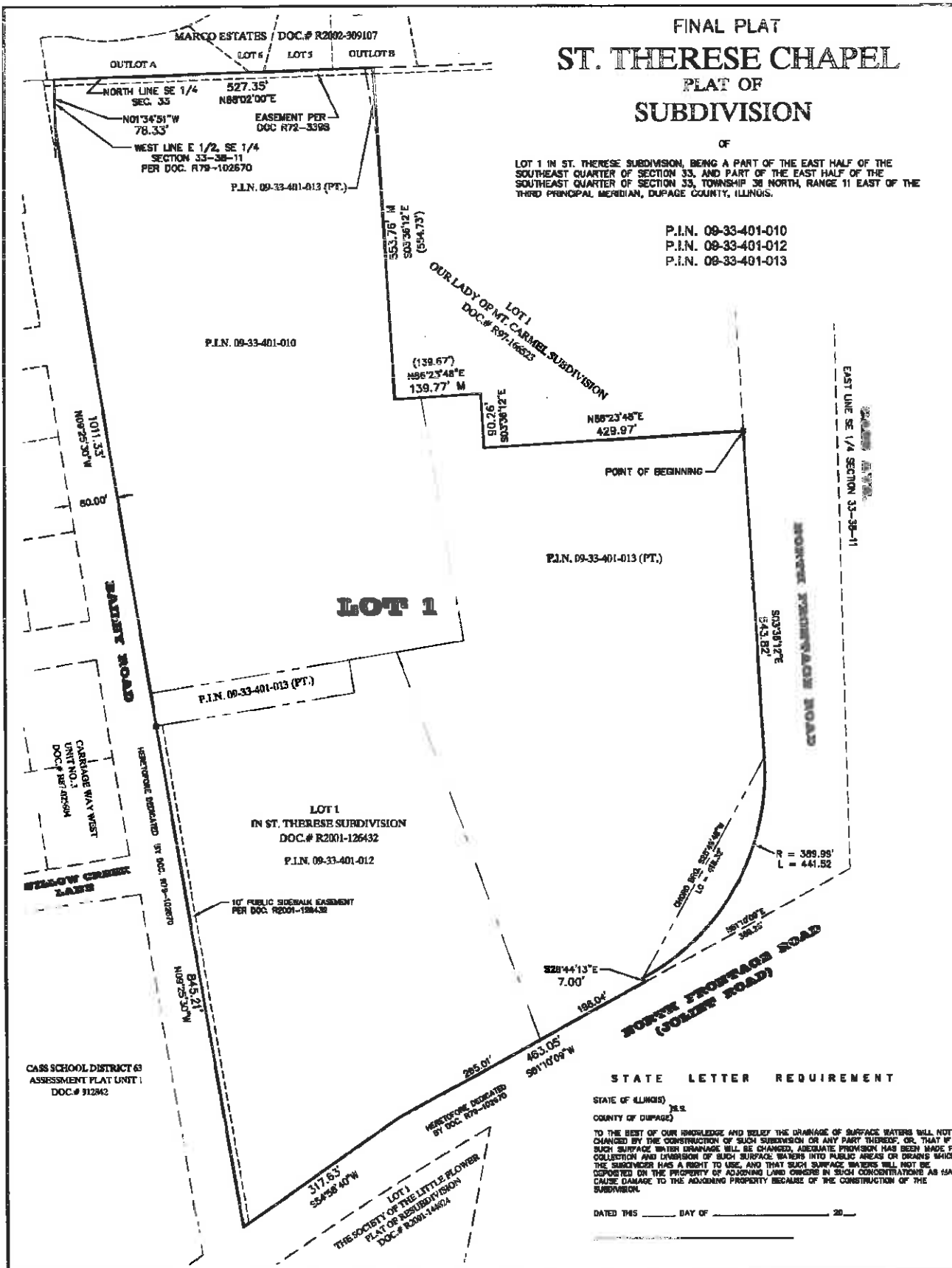

**FINAL PLAT
ST. THERESE CHAPEL
PLAT OF
SUBDIVISION**

LOT 1 IN ST. THERESE SUBDIVISION, BEING A PART OF THE EAST HALF OF THE SOUTHEAST QUARTER OF SECTION 33, AND PART OF THE EAST HALF OF THE SOUTHEAST QUARTER OF SECTION 33, TOWNSHIP 38 NORTH, RANGE 11 EAST OF THE THIRD PRINCIPAL MERIDIAN, DUPAGE COUNTY, ILLINOIS.

P.I.N. 09-33-401-010
P.I.N. 09-33-401-012
P.I.N. 09-33-401-013

OWNER'S CERTIFICATE

STATE OF ILLINOIS)
COUNTY OF DUPAGE)

THIS IS TO CERTIFY THAT THE UNDERSIGNED IS THE OWNER OF THE LAND DESCRIBED IN THE ANNEXED PLAT AND HAS CAUSED THE SAME TO BE SURVEYED AND SUBDIVIDED AS INDICATED THEREON, FOR THE USES AND PURPOSES THEREIN SET FORTH AND DOES HEREBY ACKNOWLEDGE AND ADOPT THE SAME UNDER THE TITLE AND TITLE THEREON INDICATED.

THE UNDERSIGNED HEREBY DEDICATED FOR PUBLIC USE THE LANDS SHOWN ON THIS PLAT FOR THOROUGHFARES, STREETS, ALLEYS AND PUBLIC SERVICES, AND HEREBY ALSO RESERVES AND GRANTS EASEMENTS FOR PUBLIC USE AND FOR THE INSTALLATION OF VARIOUS PUBLIC UTILITIES AS DESIGNATED AND/OR AS STATED IN THE UTILITY EASEMENT PROVISIONS STATED HEREON.

ALL EASEMENTS INDICATED AS PUBLIC UTILITY EASEMENTS ON THIS PLAT ARE RESERVED FOR AND GRANTED TO THE CITY OF DARIEN AND TO ANY ENTITY OPERATING UNDER FRANCHISE FROM THE CITY INCLUDING, BUT NOT LIMITED TO, ILLINOIS BELL TELEPHONE COMPANY, NORTHERN ILLINOIS GAS COMPANY, COMMONWEALTH Edison COMPANY, A CABLE TELEVISION OR COMMUNICATIONS COMPANY AND THEIR SUCCESSORS AND ASSIGNS FOR THE PERPETUAL RIGHT, PRIVILEGE AND AUTHORITY TO CONSTRUCT, RECONSTRUCT, REPAIR, DISCONNECT, MAINTAIN AND OPERATE VARIOUS TRANSMISSION DISTRIBUTION AND COLLECTION SYSTEMS AND ALL NECESSARY LEGAL NECESSARY PERSONNEL AND EQUIPMENT TO DO ANY OF THE ABOVE WORK. THE RIGHT IS ALSO GRANTED TO CUT DOWN, TRIM OR REMOVE ANY TREES, SHRUBS OR OTHER PLANTS ON THE EASEMENT THAT INTERFERE WITH THE OPERATION OF THE SYSTEMS OR OTHER UTILITIES. NO PERMANENT BUILDINGS OR OTHER STRUCTURES SHALL BE PLACED ON SAID EASEMENTS, BUT SAME MAY BE USED FOR GARDENS, SHRUBS, LANDSCAPING AND OTHER PURPOSES THAT DO NOT THEN OR LATER INTERFERE WITH THE APPROPRIATE USES OR RIGHTS. LOCATION OF UTILITY INSTALLATIONS WITHIN THE EASEMENT SHALL BE SUBJECT TO THE APPROVAL OF THE CITY OF DARIEN AS TO DESIGN AND LOCATION. ALL INSTALLATIONS ARE SUBJECT TO THE ORDINANCES OF THE CITY OF DARIEN.

DATED THIS _____ DAY OF _____ A.D. 20__

SIGNATURE
PLEASE TYPE/PRINT THE AUTHORIZED INDIVIDUAL'S NAME, TITLE, CORPORATION/COMPANY NAME AND ADDRESS.

AFFIX SEAL IF APPROPRIATE

NOTARY CERTIFICATE

STATE OF ILLINOIS)
COUNTY OF DUPAGE)

A NOTARY PUBLIC IN AND FOR SAID COUNTY, IN THE STATE AFORESAID, DO HEREBY CERTIFY THAT I PERSONALLY KNOW TO ME TO BE THE SAME PERSONS WHOSE NAMES ARE SUBSCRIBED TO THE AFORESAID INSTRUMENT AS SAID OWNERS, APPEARED BEFORE ME THIS DAY IN PERSON AND ACKNOWLEDGED THAT THEY SIGNED THE ANNEXED PLAT AS THEIR OWN FREE AND VOLUNTARY ACT FOR THE USES AND PURPOSES THEREIN SET FORTH.

GIVEN UNDER MY HAND AND NOTARIAL SEAL
THIS _____ DAY OF _____ A.D. 20__

NOTARY

AFFIX SEAL
MY COMMISSION EXPIRES _____

COUNTY CLERK'S CERTIFICATE

STATE OF ILLINOIS)
COUNTY OF DUPAGE)

I, _____ COUNTY CLERK OF DUPAGE COUNTY, ILLINOIS, DO HEREBY CERTIFY THAT THERE ARE NO DELINQUENT GENERAL TAXES, NO UNPAID PROPERTY TAXES AND NO UNDEMRABLE TAX SALES AGAINST ANY OF THE LAND INCLUDED IN THE ANNEXED PLAT.

GIVEN UNDER MY HAND AND SEAL AT WHEATON, ILLINOIS,
THIS _____ DAY OF _____ A.D. 20__

COUNTY CLERK

MAYOR'S CERTIFICATE

STATE OF ILLINOIS)
COUNTY OF DUPAGE)

APPROVED BY THE MAYOR OF THE CITY OF DARIEN, DUPAGE COUNTY, ILLINOIS.

DATED THIS _____ DAY OF _____ A.D. 20__

MAYOR

CITY CLERK'S CERTIFICATE

STATE OF ILLINOIS)
COUNTY OF DUPAGE)

I, _____ CITY CLERK OF THE CITY OF DARIEN, ILLINOIS, HEREBY CERTIFY THAT THE ANNEXED PLAT WAS PRESENTED TO AND BY RESOLUTION ONLY APPROVED BY THE CITY COUNCIL OF SAID CITY AT ITS MEETING HELD ON _____ AND THAT THE REQUIRED BOND OR OTHER GUARANTEE HAS BEEN POSTED FOR THE COMPLETION OF THE IMPROVEMENTS REQUIRED BY THE REGULATIONS OF SAID CITY.

IN WITNESS WHEREOF I HAVE HERETO SET MY HAND AND THE SEAL OF THE CITY OF DARIEN, ILLINOIS,
DATED THIS _____ DAY OF _____ A.D. 20__

CITY CLERK

SANITARY DISTRICT CERTIFICATE

STATE OF ILLINOIS)
COUNTY OF DUPAGE)

I, _____ DO HEREBY CERTIFY THAT THE REQUIRED LETTER OF CREDIT IS POSTED FOR THE COMPLETION OF THE IMPROVEMENTS COVERING SANITARY SEWAGE SYSTEM AND/OR SEWER LINES AND DOMESTIC WATER SUPPLY SYSTEMS AND/OR DISTRIBUTION LINES UNDER MY JURISDICTION BASED ON APPROVED ENGINEER'S PLAN AND SPECIFICATIONS PREPARED BY A REGISTERED ENGINEER.

DATED THIS _____ DAY OF _____ A.D. 20__

COUNTY SUPERINTENDENT OF PUBLIC WORKS

CITY ENGINEER'S CERTIFICATE

STATE OF ILLINOIS)
COUNTY OF DUPAGE)

I, _____ CITY ENGINEER OF THE CITY OF DARIEN, ILLINOIS, HEREBY CERTIFY THAT THE LAND IMPROVEMENTS DESCRIBED IN THE ANNEXED PLAT AND THE PLANS AND SPECIFICATIONS THEREON MEET THE TECHNICAL REQUIREMENTS OF SAID CITY AND HAVE BEEN APPROVED BY ALL PUBLIC AUTHORITIES HAVING JURISDICTION THEREON.

DATED THIS _____ DAY OF _____ A.D. 20__

CITY ENGINEER

CERTIFICATE TO SPECIAL ASSESSMENTS

STATE OF ILLINOIS)
COUNTY OF DUPAGE)

I, _____ CITY TREASURER OF THE CITY OF DARIEN, DO HEREBY CERTIFY THAT THERE ARE NO DELINQUENT OR UNPAID CURRENT OR FORFEITED SPECIAL ASSESSMENTS OF ANY DESCRIBED INSTALLATIONS THEREON THAT HAVE BEEN APPORTIONED AGAINST THE TRACT OF LAND INCLUDED IN THE PLAT.

DATED AT DARIEN, DUPAGE COUNTY, ILLINOIS, THIS _____ DAY OF _____ A.D. 20__

CITY TREASURER

PLAN COMMISSION CERTIFICATE

STATE OF ILLINOIS)
COUNTY OF DUPAGE)

APPROVED BY THE PLAN COMMISSION OF THE CITY OF DARIEN, DUPAGE COUNTY, ILLINOIS,
THIS _____ DAY OF _____ A.D. 20__

CHAIRMAN

RECORDER'S CERTIFICATE

STATE OF ILLINOIS)
COUNTY OF DUPAGE)

THIS INSTRUMENT _____ WAS FILED FOR RECORD IN THE RECORDER'S OFFICE OF DUPAGE COUNTY, ILLINOIS, ON THE _____ DAY OF _____ A.D. 20__ AT _____ O'CLOCK _____ M.

COUNTY RECORDER

SURVEYOR'S CERTIFICATE

STATE OF ILLINOIS)
COUNTY OF DUPAGE)

THIS IS TO CERTIFY THAT WE, ENGINEERING ENTERPRISES, INC., HAVE SURVEYED AND SUBDIVIDED THE FOLLOWING DESCRIBED PROPERTY, THAT PART OF THE SOUTHEAST QUARTER OF SECTION 33, TOWNSHIP 38 NORTH, RANGE 11 EAST OF THE THIRD PRINCIPAL MERIDIAN, DUPAGE COUNTY, ILLINOIS, DESCRIBED AS FOLLOWS: BEING THE SOUTHEAST CORNER OF LOT 1 IN OUR LADY OF MOUNT CARMEL SUBDIVISION, THENCE SOUTH 83 DEGREES 38 MINUTES 12 SECONDS EAST, ON THE WEST LINE OF NORTH FRONTAGE ROAD, 643.85 FEET TO A POINT OF CURVATURE, THENCE SOUTHWESTERLY 44.83 FEET ON A CURVE TO THE POINT OF BEGINNING, BEING 50 FEET, CHORD BEING SOUTH 89 DEGREES 48 SECONDS WEST, AND CHORD LENGTH OF 410.32 FEET; THENCE SOUTH 34 DEGREES 44 MINUTES 13 SECONDS EAST, 7.00 FEET TO THE NORTH LINE OF JULET ROAD ACCORDING TO DOCUMENT #78-10270; THENCE SOUTH 01 DEGREE 30 MINUTES 09 SECONDS WEST, ON SAID NORTH LINE, 190.04 FEET TO THE SOUTHEAST CORNER OF LOT 1 IN ST. THERESE SUBDIVISION, RECORDED AS DOCUMENT #2001-126432; THENCE CONTINUING SOUTH 01 DEGREE 10 MINUTES 00 SECONDS WEST, ON THE SOUTH LINE OF SAID LOT 1, 30.00 FEET; THENCE SOUTH 34 DEGREES 30 MINUTES 40 SECONDS WEST, ON SAID SOUTH LINE, 307.83 FEET TO THE WEST LINE OF SAID LOT 1; THENCE NORTH 00 DEGREES 25 MINUTES 30 SECONDS WEST, ON SAID WEST LINE, 148.11 FEET TO THE NORTHWEST CORNER OF SAID LOT 1; THENCE CONTINUING NORTH 00 DEGREES 25 MINUTES 30 SECONDS WEST, ON THE EAST LINE OF SAID ROAD, ACCORDING TO DOCUMENT #78-10270, 103.33 FEET TO THE WEST LINE OF THE EAST HALF OF THE SOUTHWEST QUARTER OF SAID SECTION 33; THENCE NORTH 01 DEGREE 34 MINUTES 31 SECONDS WEST, ON SAID WEST LINE, 76.33 FEET TO THE NORTH LINE OF THE SOUTHWEST QUARTER OF SAID SECTION 33; THENCE NORTH 00 DEGREES 00 MINUTES 00 SECONDS EAST, ON SAID NORTH LINE, 527.35 FEET TO THE WEST LINE OF LOT 1 IN SAID OUR LADY OF MOUNT CARMEL SUBDIVISION; THENCE SOUTH 83 DEGREES 38 MINUTES 12 SECONDS EAST, ON SAID NORTH LINE, 353.76 FEET TO THE SOUTH LINE OF SAID LOT 1; THENCE NORTH 00 DEGREES 23 MINUTES 48 SECONDS EAST, ON SAID SOUTH LINE, 139.77 FEET; THENCE SOUTH 00 DEGREES 38 MINUTES 12 SECONDS EAST, ON SAID SOUTH LINE, 92.56 FEET; THENCE NORTH 88 DEGREES 23 MINUTES 48 SECONDS EAST, ON SAID SOUTH LINE, 429.97 FEET TO THE POINT OF BEGINNING.

AS SHOWN BY THE ANNEXED PLAT, WHICH IS A CORRECT REPRESENTATION OF SAID SURVEY AND SUBDIVISION, ALL DISTANCES ARE SHOWN IN FEET AND DECIMALS THEREOF. I FURTHER CERTIFY THAT ALL REGULATIONS ENACTED BY THE MAYOR AND CITY COUNCIL OF THE CITY OF DARIEN RELATIVE TO PLATS AND SUBDIVISIONS HAVE BEEN COMPLIED WITH IN PREPARATION OF THIS PLAT. I FURTHER CERTIFY THAT THE LAND IS WITHIN THE CITY OF DARIEN (OR WITHIN ONE AND ONE-HALF (1 1/2) MILES OF THE CORPORATE LIMITS OF THE CITY OF DARIEN) WHICH HAS ADOPTED A CITY COMPREHENSIVE PLAN AND MAP AND IS EXERCISING THE SPECIAL POWERS AUTHORIZED BY DIVISION 12 OF ARTICLE 11 OF THE ILLINOIS MUNICIPAL CODE AS AMENDED. I FURTHER CERTIFY THAT THE LANDS SHOWN ON THIS PLAT ARE NOT SITUATED WITHIN 500 FEET OF ANY SURFACE DRAIN OR WATERCOURSE SERVING A TRIBUTARY AREA OF 840 ACRES OR MORE AND THIS PLAT HAS BEEN REVIEWED BY THE DEPARTMENT OF PUBLIC WORKS AND BUILDINGS FOR THE PURPOSES OF DETERMINING, FOR THE PROTECTION OF PERSONS AND PROPERTY, THE FLOOD HAZARDS INVOLVED AND A REPORT THEREON FILED BY THAT DEPARTMENT WITH THE RECORDER OF DEEDS.

GIVEN UNDER MY HAND AND SEAL AT SUGAR GROVE, ILLINOIS, ON THE _____ DAY OF _____ A.D. 2015.

FOR REVIEW
CHRIS E. PETERSON
PROFESSIONAL LAND SURVEYOR #0978
(RENEWAL 11-30-2015)
ENGINEERING ENTERPRISES, INC.
PROFESSIONAL DESIGN FIRM #184-002003
(RENEWAL 04/30/2017)

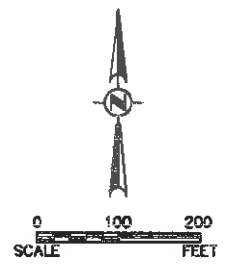

Engineering Enterprises, Inc.
CONSULTING ENGINEERS
52 Wheeler Road
Sugar Grove, Illinois 60554
630.488.6700 / www.eefweb.com

SOCIETY OF THE LITTLE FLOWER
1313 N. FRONTAGE ROAD
DARIEN, IL 60561

NO.	DATE	REVISIONS
1	12-14-2015	REVIEW SUBMITTAL

**ST. THERESE CHAPEL
PLAT OF SUBDIVISION**

DATE: DECEMBER, 2015
PROJECT NO. P15008
FILE NO P15008 PLAT OF SUBDIVISION
PAGE 1 OF 1

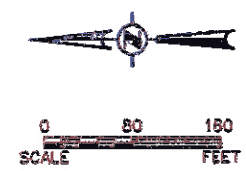
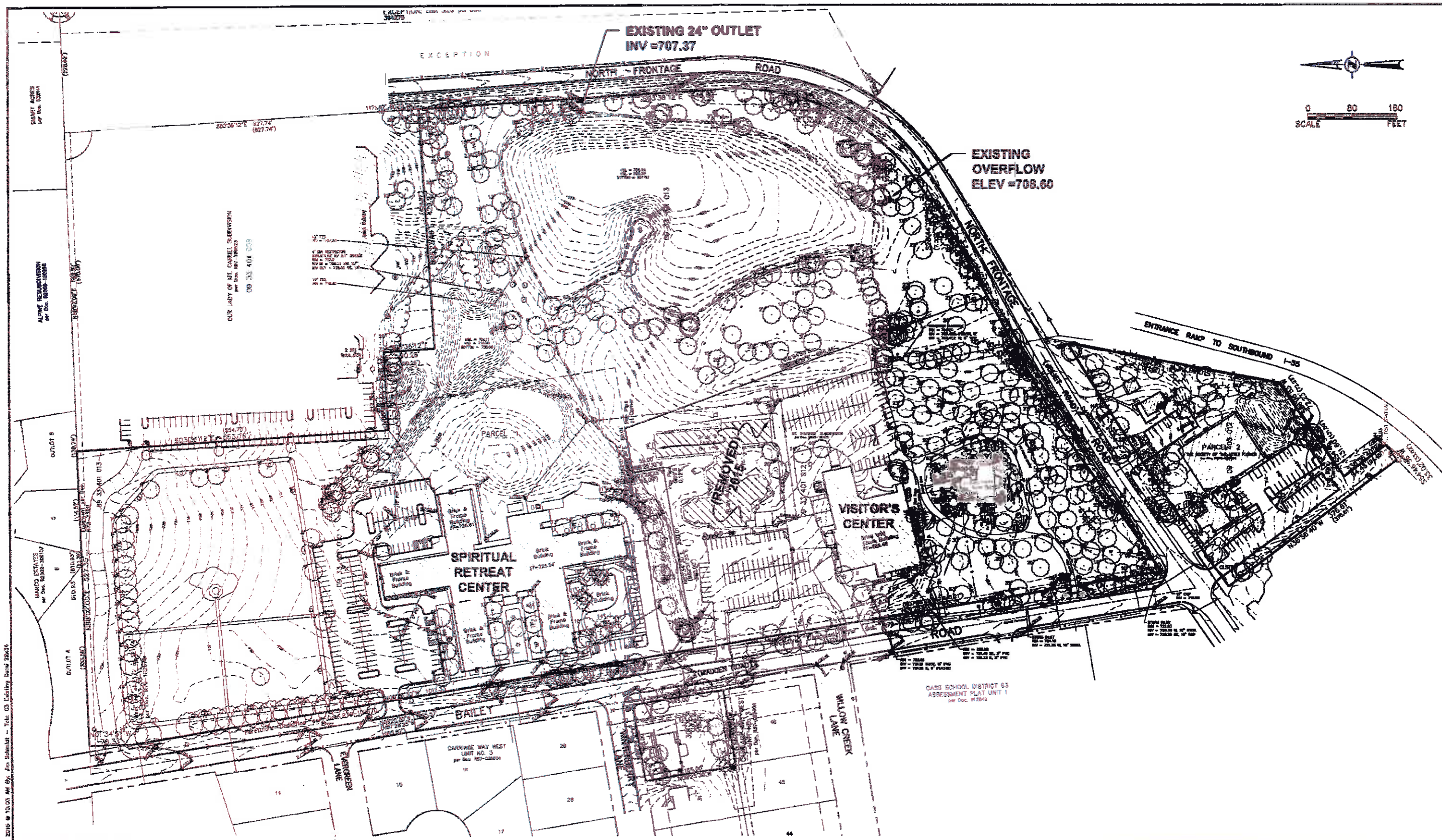

14, 2015 @ 10:03 AM By: Jim Stankin - Tot: 03 Calling Band 28236
 COPYRIGHT © 2015 ENGINEERING ENTERPRISES, INC.

Engineering Enterprises, Inc.
 CONSULTING ENGINEERS
 52 Wheeler Road
 Sugar Grove, Illinois 60554
 630.466.6700 / www.eehwb.com

SOCIETY OF THE LITTLE FLOWER
 1313 N. FRONTAGE ROAD
 DARIEN, IL 60561

NO.	DATE	REVISIONS

NATIONAL SHRINE OF ST. THERESE
ST. THERESE CHAPEL
 SITE PLAN

EXISTING CONDITIONS

DATE: DECEMBER 2015
 PROJECT NO: P15009
 FILE: P15009-EXISTING
 SHEET **3** OF **15**

SHEET 3 OF 15 - EXISTING

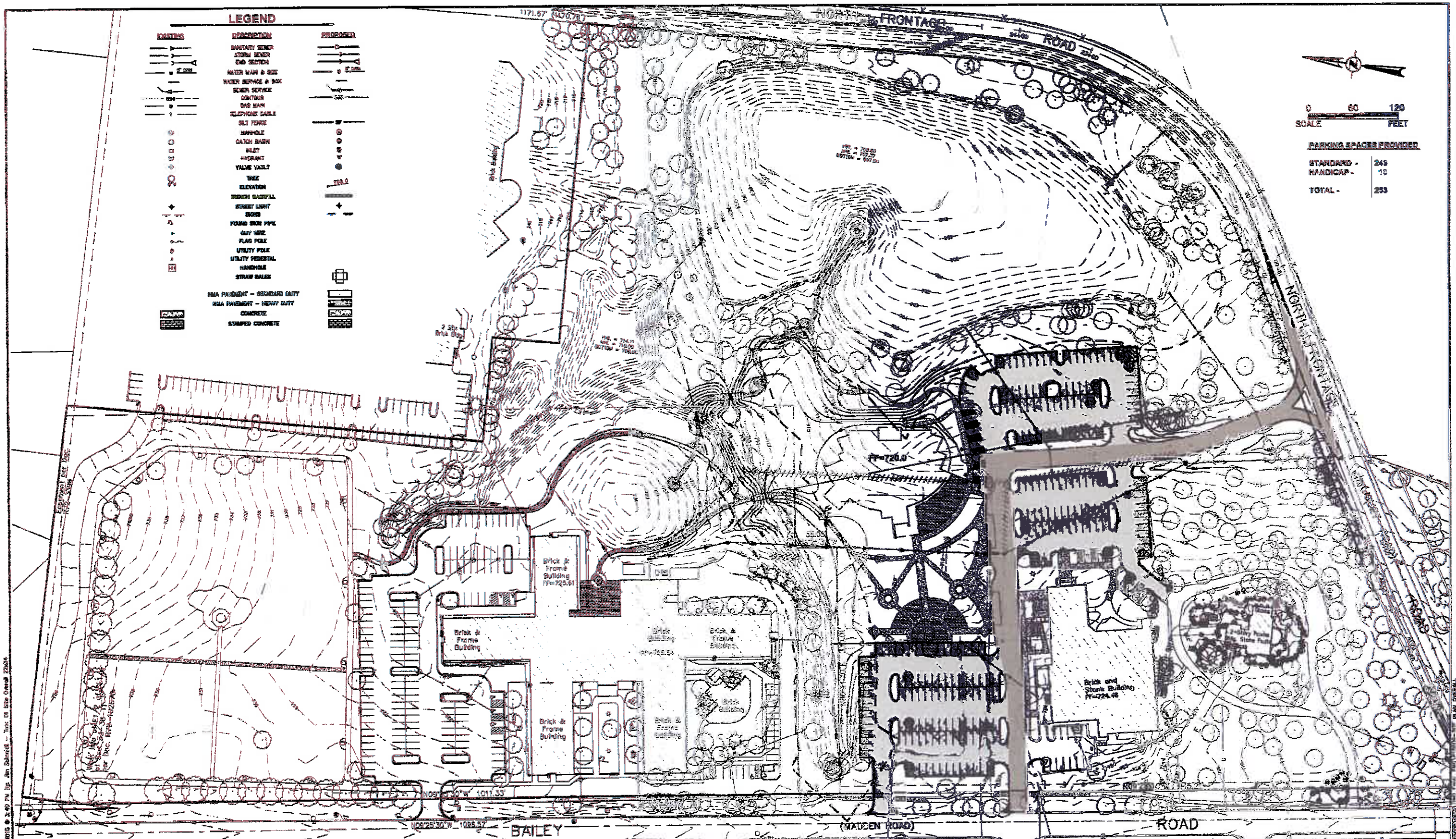

LEGEND

EXISTING	DESCRIPTION	PROPOSED
[Symbol]	SEWER MAIN	[Symbol]
[Symbol]	STORM MAIN	[Symbol]
[Symbol]	WATER MAIN & BOX	[Symbol]
[Symbol]	SEWER SERVICE & BOX	[Symbol]
[Symbol]	SEWER SERVICE	[Symbol]
[Symbol]	SEWER MANHOLE	[Symbol]
[Symbol]	SEWER MANHOLE	[Symbol]
[Symbol]	TELEPHONE CABLE	[Symbol]
[Symbol]	SILT PILE	[Symbol]
[Symbol]	MANHOLE	[Symbol]
[Symbol]	CATCH BASIN	[Symbol]
[Symbol]	WELT	[Symbol]
[Symbol]	HYDRANT	[Symbol]
[Symbol]	VALVE VAULT	[Symbol]
[Symbol]	TRIE	[Symbol]
[Symbol]	ELEVATION	[Symbol]
[Symbol]	TERRAIN SURFILL	[Symbol]
[Symbol]	STREET LIGHT	[Symbol]
[Symbol]	BIOS	[Symbol]
[Symbol]	FOUND IRON PIPE	[Symbol]
[Symbol]	GUY WIRE	[Symbol]
[Symbol]	FLAG POLE	[Symbol]
[Symbol]	UTILITY POLE	[Symbol]
[Symbol]	UTILITY FURNITURE	[Symbol]
[Symbol]	HANDHOLE	[Symbol]
[Symbol]	STRAW BALE	[Symbol]
[Symbol]	HMA PAVEMENT - STANDARD DUTY	[Symbol]
[Symbol]	HMA PAVEMENT - HEAVY DUTY	[Symbol]
[Symbol]	CONCRETE	[Symbol]
[Symbol]	STAMPED CONCRETE	[Symbol]

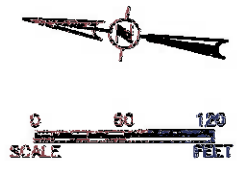

PARKING SPACES PROVIDED

STANDARD -	249
HANDICAP -	10
TOTAL -	259

Engineering Enterprises, Inc.
CONSULTING ENGINEERS
52 Wheeler Road
Sugar Grove, Illinois 60554
630.486.8700 / www.ee1web.com

SOCIETY OF THE LITTLE FLOWER
1313 N. FRONTAGE ROAD
DARIEN, IL 60561

NO.	DATE	REVISIONS

NATIONAL SHRINE OF ST. THERESE
ST. THERESE CHAPEL
SITE PLAN

OVERALL SITE PLAN

DATE: DECEMBER 2015
PROJECT NO: P18008
RECORDS-SITE PLAN OVERALL
SHEET 1 of 1

11/18/15 2:40 PM By: Jim Schmitt - Title D1 Site Overall 220x30

11/18/15 2:40 PM By: Jim Schmitt - Title D1 Site Overall 220x30

AGENDA MEMO
Municipal Services Committee Meeting
March 28, 2016

ISSUE STATEMENT

Approval of a resolution awarding a contract extension for the 2016 Street Sweeping Services between the City of Darien and Illinois Central Sweeping in an amount not to exceed \$35,775.00.

BACKGROUND/HISTORY

The proposed contract is the 1st of two optional annual contract extensions. The Street Sweeping Contract was awarded to Illinois Central Sweeping on April 6, 2015, Res No. R-44-15 with two option annual contract extensions. Illinois Central Sweeping has acknowledged the extension and accepts the extension as presented. Additionally, an amount of \$1,000 has been designated as a contingency for additional hours required for miscellaneous sweepings and emergency events. Attached and labeled as Attachment A is the bid tally.

The proposed expenditure would be expended from the following FY 16-17 Account:

ACCOUNT NUMBER	ACCOUNT DESCRIPTION	FY 16-17 BUDGET	PROPOSED EXPENDITURE
01-30-4373	May 11 th – 19 th	\$7,070.00	\$7,070.00
01-30-4373	Sept 14 th – 21 st	\$7,070.00	\$7,070.00
01-30-4373	Oct 26 th – Nov 16 th	\$13,635.00	\$13,635.00
01-30-4373	EMERGENCY SWEEPS	\$500.00	TBD
01-30-4373	CONTINGENCY	\$1,000.00	TBD
01-30-4373	DISPOSAL	\$6,500.00	\$6,500.00
TOTAL		\$35,775.00	N/A

STAFF RECOMMENDATION

Staff recommends approval of this resolution with Illinois Central Sweeping. The City of Darien had satisfactory results this past year with Illinois Central Sweeping.

ALTERNATE CONSIDERATION

Not approving this proposal.

DECISION MODE

This item will be placed on the agenda for the April 4, 2016 City Council agenda for formal approval.

SEALED BID: 2015-2017 Street Sweeping Services
 OPENING DATE/TIME: January 6, 2015 @ 10:00 a.m.

2015 PRICING SCHEDULE		Elgin Sweeping Services, Inc.		Hoving Clean Sweep, LLC		Illinois Central Sweeping		Waste Management		
CYCLE	DESCRIPTION	ESTIMATED UNITS	HOURLY RATE	HOURLY RATE	HOURLY RATE	HOURLY RATE	HOURLY RATE	HOURLY RATE	HOURLY RATE	
1	MAY 11 - MAY 18	70	\$ 132.00	\$ 9,240.00	\$ 105.00	\$ 7,350.00	\$ 97.00	\$ 6,790.00	\$ 115.00	\$ 8,050.00
2	JULY 13- JULY 20	70	\$ 132.00	\$ 9,240.00	\$ 105.00	\$ 7,350.00	\$ 97.00	\$ 6,790.00	\$ 115.00	\$ 8,050.00
3	SEPTEMBER 14-SEPTEMBER 21	70	\$ 132.00	\$ 9,240.00	\$ 105.00	\$ 7,350.00	\$ 97.00	\$ 6,790.00	\$ 115.00	\$ 8,050.00
4	NOVEMBER 13-NOVEMBER 26	135	\$ 132.00	\$ 17,820.00	\$ 135.00	\$ 18,225.00	\$ 97.00	\$ 13,095.00	\$ 137.00	\$ 18,495.00
SUBTOTAL-A		345		\$ 45,540.00		\$ 40,275.00		\$ 33,465.00		\$ 42,645.00
EMERGENCY CALL OUT		3	\$ 190.00	\$ 570.00	\$ 105.00	\$ 315.00	\$ 100.00	\$ 300.00	\$ 180.00	\$ 540.00
SUBTOTAL-B				\$ 570.00		\$ 315.00		\$ 300.00		\$ 540.00
TOTAL COST				\$ 46,110.00		\$ 40,590.00		\$ 33,765.00		\$ 43,185.00
2015 BUDGET				\$ 46,110.00		\$ 40,590.00		\$ 33,765.00		\$ 43,185.00
2016 PRICING SCHEDULE		Elgin Sweeping Services, Inc.		Hoving Clean Sweep, LLC		Illinois Central Sweeping		Waste Management		
CYCLE	DESCRIPTION	ESTIMATED UNITS	HOURLY RATE	HOURLY RATE	HOURLY RATE	HOURLY RATE	HOURLY RATE	HOURLY RATE	HOURLY RATE	
1	MAY 9 - MAY 18	70	\$ 136.00	\$ 9,520.00	\$ 107.63	\$ 7,534.10	\$ 101.00	\$ 7,070.00	\$ 118.00	\$ 8,260.00
2	JULY 11- JULY 18	70	\$ 136.00	\$ 9,520.00	\$ 107.63	\$ 7,534.10	\$ 101.00	\$ 7,070.00	\$ 118.00	\$ 8,260.00
3	SEPTEMBER 14-SEPTEMBER 21	70	\$ 136.00	\$ 9,520.00	\$ 107.63	\$ 7,534.10	\$ 101.00	\$ 7,070.00	\$ 118.00	\$ 8,260.00
4	NOVEMBER 14-NOVEMBER 23	135	\$ 136.00	\$ 18,360.00	\$ 138.38	\$ 18,681.30	\$ 101.00	\$ 13,635.00	\$ 140.00	\$ 18,900.00
SUBTOTAL-A		345		\$ 46,920.00		\$ 41,283.60		\$ 34,845.00		\$ 43,680.00
EMERGENCY CALL OUT		3	\$ 196.00	\$ 588.00	\$ 107.63	\$ 322.89	\$ 105.00	\$ 315.00	\$ 185.00	\$ 555.00
SUBTOTAL-B				\$ 588.00		\$ 322.89		\$ 315.00		\$ 555.00
TOTAL COST				\$ 47,508.00		\$ 41,606.49		\$ 35,160.00		\$ 44,235.00
2016 BUDGET				\$ 47,508.00		\$ 41,606.49		\$ 35,160.00		\$ 44,235.00
2017 PRICING SCHEDULE		Elgin Sweeping Services, Inc.		Hoving Clean Sweep, LLC		Illinois Central Sweeping		Waste Management		
CYCLE	DESCRIPTION	ESTIMATED UNITS	HOURLY RATE	HOURLY RATE	HOURLY RATE	HOURLY RATE	HOURLY RATE	HOURLY RATE	HOURLY RATE	
1	MAY 8 - MAY 15	70	\$ 140.00	\$ 9,800.00	\$ 110.32	\$ 7,722.40	\$ 105.00	\$ 7,350.00	\$ 122.00	\$ 8,540.00
2	JULY 10- JULY 17	70	\$ 140.00	\$ 9,800.00	\$ 110.32	\$ 7,722.40	\$ 105.00	\$ 7,350.00	\$ 122.00	\$ 8,540.00
3	SEPTEMBER 14-SEPTEMBER 21	70	\$ 140.00	\$ 9,800.00	\$ 110.32	\$ 7,722.40	\$ 105.00	\$ 7,350.00	\$ 122.00	\$ 8,540.00
4	NOVEMBER 13-NOVEMBER 22	135	\$ 140.00	\$ 18,900.00	\$ 141.84	\$ 19,148.40	\$ 105.00	\$ 14,175.00	\$ 145.00	\$ 19,575.00
SUBTOTAL-A		345		\$ 48,300.00		\$ 42,315.60		\$ 36,225.00		\$ 45,195.00
EMERGENCY CALL OUT		3	\$ 202.00	\$ 606.00	\$ 110.32	\$ 330.96	\$ 109.00	\$ 327.00	\$ 190.00	\$ 570.00
SUBTOTAL-B				\$ 606.00		\$ 330.96		\$ 327.00		\$ 570.00
TOTAL COST				\$ 48,906.00		\$ 42,646.56		\$ 36,552.00		\$ 45,765.00
2017 BUDGET				\$ 48,906.00		\$ 42,646.56		\$ 36,552.00		\$ 45,765.00

RESOLUTION NO. _____

**A RESOLUTION AUTHORIZING THE MAYOR AND CITY CLERK TO ENTER INTO
A CONTRACT EXTENSION FOR THE 2016 STREET SWEEPING SERVICES
BETWEEN THE CITY OF DARIEN AND ILLINOIS CENTRAL SWEEPING IN AN
AMOUNT NOT TO EXCEED \$35,775.00**

**BE IT RESOLVED BY THE CITY COUNCIL OF THE CITY OF DARIEN, DU PAGE
COUNTY, ILLINOIS, as follows:**

SECTION 1: The City Council of the City of Darien hereby authorizes the Mayor and City Clerk to enter into a Contract Extension, a copy of which is attached hereto as "**Exhibit A**", for the 2016 Street Sweeping Services between the City of Darien and Illinois Central Sweeping in an amount not to exceed \$35,775.00.

SECTION 2: This Resolution shall be in full force and effect from and after its passage and approval as provided by law.

**PASSED BY THE CITY COUNCIL OF THE CITY OF DARIEN, DU PAGE COUNTY,
ILLINOIS, this 4th day of April, 2016.**

AYES: _____

NAYS: _____

ABSENT: _____

**APPROVED BY THE MAYOR OF THE CITY OF DARIEN, DU PAGE COUNTY,
ILLINOIS, this 4th day of April, 2016.**

KATHLEEN MOESLE WEAVER, MAYOR

ATTEST:

JOANNE E. RAGONA, CITY CLERK

APPROVED AS TO FORM

CITY ATTORNEY

BIDDER SUMMARY SHEET

STREET SWEEPING SERVICES FOR THE CITY OF DARIEN - 2015

Firm Name: ILLINOIS Central Sweeping

Address: 2307 W. 135TH ST.

City, State, Zip Code: Blue Island IL. 60406

Contact Person: Dan Overland

FEIN #: 20-0991504

Phone: (708) 293 0000 Fax: (708) 293 8319

Mobile: (708) 878 9230

E-mail Address: doverland@illinoiscentralsweeping.com

RECEIPT OF ADDENDA: The receipt of the following addenda is hereby acknowledged:

Addendum No. _____, Dated _____

Addendum No. _____, Dated _____

Schedule of Prices for:

STREET SWEEPING SERVICES

2016 SWEEPING PROGRAM 4-SWEEPINGS				
STREET SWEEPING SERVICES SCHEDULE	ESTIMATED UNITS	UNIT	COST PER HOUR	TOTAL COST
MAY 9TH - MAY 18TH	70	HOURLY	\$101.00	\$7,070.00
JULY 11TH - JULY 18TH	70	HOURLY	\$101.00	\$7,070.00
SEPTEMBER 14TH - SEPTEMBER 21ST	70	HOURLY	\$101.00	\$7,070.00
NOVEMBER 14 - NOVEMBER 23RD	135	HOURLY	\$101.00	\$13,635.00
SUB-TOTAL-A	345			\$34,845.00
EMERGENCY SERVICES	ESTIMATED UNITS	UNIT	COST PER HOUR	TOTAL COST
EMERGENCY CALL OUT	3	HOURLY	\$105.00	\$315.00
SUB-TOTAL-B	3			\$315.00
TOTALS-SUBTOTAL A & B 2016				\$35,160.00
DATES INDICATE TENTATIVE START DATE PERIOD				

TOTAL COST SUMMARY

SUMMARY COSTS	2015	2016	2017
Part A Sub-Total	\$33,465.00	\$34,845.00	\$36,225.00
Part B Sub-Total	\$300.00	\$315.00	\$327.00
Total Cost of A+B	\$33,765.00	\$35,160.00	\$36,552.00

The contract will be awarded on a total sum of A and B.

Firm Name: Illinois Central Sweeping

Signature of Authorized Representative: 

Title: Owner Date: 1/5/2015

ACCEPTANCE: This proposal is valid for 150 calendar days from the date of submittal.

BUSINESS ORGANIZATION:

 Sole Proprietor: An individual whose signature is affixed to this bid.

 Partnership: Attach sheet and state full names, titles and address of all responsible principals and/or partners.

 X Corporation: State of incorporation: LLC, Illinois

Provide a disclosure of all officers and principals by name and business address, date of incorporation and indicate if the corporation is authorized to do business in Illinois. In submitting this bid, it is understood that the City of Darien reserves the right to reject any or all bids, to accept an alternate bid, and to waive any informalities in any bid. In compliance with your Invitation to Bid, and subject to all conditions thereof, the undersigned offers and agrees, if this bid is accepted, to furnish the services as outlined.

Illinois Central Sweeping (Corporate Seal)
Business Name

Signature

Charles DeVries
Print or type name

Owner
Title

1/6/2015
Date

This Contract is made this 6th day of April, 2015 by and between the City of Darien (hereinafter referred to as the "CITY") and ILLINOIS Central Sweeping (hereinafter referred to as the "CONTRACTOR").

WITNESSETH

In consideration of the promises and covenants made herein by the CITY and the CONTRACTOR (hereinafter referred to collectively as the "PARTIES"), the PARTIES agree as follows:

SECTION 1: THE CONTRACT DOCUMENTS: This Contract shall include the following documents (hereinafter referred to as the "CONTRACT DOCUMENTS") however this Contract takes precedence and controls over any contrary provision in any of the CONTRACT DOCUMENTS. The Contract, including the CONTRACT DOCUMENTS, expresses the entire agreement between the PARTIES and where it modifies, adds to or deletes provisions in other CONTRACT DOCUMENTS; the Contract's provisions shall prevail. Provisions in the CONTRACT DOCUMENTS unmodified by this Contract shall be in full force and effect in their unaltered condition.

The Invitation to Bid

The Instructions to the Bidders

This Contract

The Terms and Conditions

The Bid as it is responsive to the CITY'S bid requirements

All Certifications required by the City

Certificates of insurance

Performance and Payment Bonds as may be required by the CITY

SECTION 2: SCOPE OF THE WORK AND PAYMENT: The CONTRACTOR agrees to provide labor, equipment and materials necessary to provide the services as described in the CONTRACT DOCUMENTS and further described below:

2012 STREET SWEEPING SERVICES

(Hereinafter referred to as the "WORK") and the CITY agrees to pay the CONTRACTOR pursuant to the provisions of the Local Government Prompt Payment Act (50 ILCS 505/1 *et seq.*) the following amount for performance of the described unit prices.

SECTION 3: ASSIGNMENT: CONTRACTOR shall not assign the duties and obligations involved in the performance of the WORK which is the subject matter of this Contract without the written consent of the CITY.

SECTION 4: TERM OF THE CONTRACT: This Contract shall commence on the date of its execution. The WORK shall commence upon receipt of a Notice to Proceed and continue for the period specified. This Contract shall terminate upon completion of the WORK, but may be terminated by either of the PARTIES for default upon failure to cure after ten (10) days prior written notice of said default from the aggrieved PARTY. The CITY, for its convenience, may terminate this Contract with thirty (30) days prior written notice.

SECTION 5: INDEMNIFICATION AND INSURANCE: The CONTRACTOR shall indemnify and hold harmless the CITY, its officials, officers, directors, agents, employees and representatives and assigns, from lawsuits, actions, costs (including attorneys' fees), claims or liability of any character, incurred due to the alleged negligence of the CONTRACTOR, brought because of any injuries or damages received or sustained by any person, persons or property on account of any act or omission, neglect or misconduct of said CONTRACTOR, its officers, agents and/or employees arising out of, or in performance of any of the provisions of the CONTRACT DOCUMENTS, including any claims or amounts recovered for any infringements of patent, trademark or copyright; or from any claims or amounts arising or recovered under the

"Worker's Compensation Act" or any other law, ordinance, order or decree. In connection with any such claims, lawsuits, actions or liabilities, the CITY, its officials, officers, directors, agents, employees, representatives and their assigns shall have the right to defense counsel of their choice. The CONTRACTOR shall be solely liable for all costs of such defense and for all expenses, fees, judgments, settlements and all other costs arising out of such claims, lawsuits, actions or liabilities. The Contractor shall not make any settlement or compromise of a lawsuit or claim, or fail to pursue any available avenue of appeal of any adverse judgment, without the approval of the City and any other indemnified party. The City or any other indemnified party, in its or their sole discretion, shall have the option of being represented by its or their own counsel. If this option is exercised, then the Contractor shall promptly reimburse the City or other indemnified party, upon written demand, for any expenses, including but not limited to court costs, reasonable attorneys' and witnesses' fees and other expenses of litigation incurred by the City or other indemnified party in connection therewith. Execution of this Contract by the CITY is contingent upon receipt of Insurance Certificates provided by the CONTRACTOR in compliance with the CONTRACT DOCUMENTS.

SECTION 6: COMPLIANCE WITH LAWS: The bidder shall at all times observe and comply with all laws, ordinances and regulations of the federal, state, local and City governments, which may in any manner affect the preparation of bids or the performance of the Contract. Bidder hereby agrees that it will comply with all requirements of the Illinois Human Rights Act, 775 ILCS 5/1-101 et seq., including the provision dealing with sexual harassment and that if awarded the Contract will not engage in any prohibited form of discrimination in employment as defined in that Act and will require that its subcontractors agree to the same restrictions. The contractor shall maintain, and require that its subcontractors maintain, policies of equal employment opportunity which shall prohibit discrimination against any employee or applicant for employment on the basis of race, religion, color, sex, national origin, ancestry, citizenship status, age, marital status, physical or mental disability unrelated to the individual's ability to perform the essential functions of the job, association with a person with a disability, or unfavorable discharge from military service. Contractors and all subcontractors shall comply with all requirements of the Act and of the Rules of the Illinois Department of Human Rights with regard to posting information on employees' rights under the Act. Contractors and all subcontractors shall place appropriate statements identifying their companies as equal opportunity employers in all advertisements for workers to be employed in work to be performed. Not less than the Prevailing Rate of Wages as found by the City of Darien or the Department of Labor shall be paid to laborers, workmen, and mechanics performing work under the Contract. If awarded the Contract, contractor must comply with all provisions of the Illinois Prevailing Wage Act, including, but not limited to, providing certified payroll records to the Municipal Services Department. Contractor and subcontractors shall be required to comply with all applicable federal laws, state laws and regulations regarding minimum wages, limit on payment to minors, minimum fair wage standards for minors, payment of wage due employees, and health and safety of employees. Contractor and subcontractor are required to pay employees all rightful salaries, medical benefits, pension and social security benefits pursuant to applicable labor agreements and federal and state statutes and to further require withholdings and deposits therefore. The CONTRACTOR shall obtain all necessary local and state licenses and/or permits that may be required for performance of the WORK and provide those licenses to the CITY prior to commencement of the WORK if applicable.

SECTION 7: NOTICE: Where notice is required by the CONTRACT DOCUMENTS it shall be considered received if it is delivered in person, sent by registered United States mail, return receipt requested, delivered by messenger or mail service with a signed receipt, sent by facsimile or e-mail with an acknowledgment of receipt, to the following:

City of Darien
1702 Plainfield Road
Darien, IL 60561
Attn: Director of Municipal Services

SECTION 8: STANDARD OF SERVICE: Services shall be rendered to the highest professional standards to meet or exceed those standards met by others providing the same or similar services in the Chicagoland area. Sufficient competent personnel shall be provided who with supervision shall complete the services required within the time allowed for performance. The CONTRACTOR'S personnel shall, at all times present a neat appearance and shall be trained to handle all contact with City residents or City employees in a respectful manner. At the request of the Director of Municipal Services or a designee, the CONTRACTOR shall replace any incompetent, abusive or disorderly person in its employ.

SECTION 9: PAYMENTS TO OTHER PARTIES: The CONTRACTOR shall not obligate the CITY to make payments to third parties or make promises or representations to third parties on behalf of the CITY without prior written approval of the City Administrator or a designee.

SECTION 10: COMPLIANCE: CONTRACTOR shall comply with all of the requirements of the Contract Documents, including, but not limited to, the Illinois Prevailing Wage Act where applicable and all other applicable local, state and federal statutes, ordinances, codes, rules and regulations.

SECTION 11: LAW AND VENUE: The laws of the State of Illinois shall govern this Contract and venue for legal disputes shall be DuPage County, Illinois.

SECTION 12: MODIFICATION: This Contract may be modified only by a written amendment signed by both PARTIES.

FOR: THE CITY

FOR: THE CONTRACTOR

By: Kathleen Moesle Weaver

By: [Signature]

Print Name: Kathleen Moesle Weaver

Print Name: CHARLES DE VRIES

Title: Mayor

Title: OWNER

Date: April 6, 2015

Date: 4-7-15

Lisa Klemm

From: kdevries@illinoiscentralsweeping.com
Sent: Wednesday, March 09, 2016 10:43 AM
To: Lisa Klemm
Cc: Chuck Devries
Subject: Re: City of Darien - Contract Extension 2016
Attachments: Street Sweeping Extension.pdf

Hi Lisa

Yes, we are good with the 2016 pricing as indicated in bid

Thank you

Karen DeVries

Illinois Central Sweeping

From: Lisa Klemm <LKlemm@darienil.gov>
To: "kdevries@illinoiscentralsweeping.com" <kdevries@illinoiscentralsweeping.com>
Sent: Wednesday, March 9, 2016 9:40 AM
Subject: FW: City of Darien - Contract Extension 2016

Karen,

Please see below and attached! Thank you!

Lisa A Klemm

City of Darien
630-353-8105

To receive important information from the City of Darien sign up for our electronic newsletter:

DARIEN DIRECT CONNECT

Follow the link and subscribing is simple!

<http://www.darien.il.us/Reference-Desk/DirectConnect.aspx>

From: Lisa Klemm
Sent: Tuesday, March 08, 2016 11:57 AM
To: 'droverland@illinoiscentralsweeping.com' <droverland@illinoiscentralsweeping.com>
Cc: Dan Gombac <dgombac@darienil.gov>
Subject: City of Darien - Contract Extension 2016

Good AM!

Attached please find the results of the original bid tally for the City of Darien – Street Sweeping Services. Please review, and, if in agreement with the 2016 Pricing Scheduling, let us know at your earliest convenience.

Thank you in advance for your attention to this matter.

Lisa A Klemm

City of Darien

630-353-8105

To receive important information from the City of Darien sign up for our electronic newsletter:

DARIEN DIRECT CONNECT

Follow the link and subscribing is simple!

<http://www.darien.il.us/Reference-Desk/DirectConnect.aspx>

AGENDA MEMO
Municipal Services
March 28, 2016

Issue Statement

Approval of a **resolution** to extend a contract with Rag's Electric Company for the annual 2016/17 Street Light Maintenance Contract. The proposed contract extension would be the first extension, year 2, of a three (3) year contract.

Background/History

On March 12, 2015 staff had received three sealed bids for the 2015/16 street light maintenance contract. Attached, please find the bid tabulation labeled as **Attachment A** for the costs to repair street lights, hourly rates for labor, equipment, and material costs. The attached tabulation also includes a pricing schedule for two additional option years.

Below, please find a summary of the items within the proposed contract and attached please find **Attachment B**-labeled as Repair Cost Estimates for 2016/17.

Item 1A-Cost to Repair Street Light-This item requires the vendor to repair the street light at a specified unit cost. The repair would include equipment labor and the light bulb.

Item 1B-Cost to Repair Ballast-This item requires the vendor to repair the ballast at a specified unit cost. The repair would include equipment labor and the ballast.

Item 1C-Cost to Repair Fuse Kit-This item requires the vendor to repair the fuse kit at a specified unit cost. The repair would include equipment labor and the fuse kit.

Item 2-Hourly Rate for Labor and Equipment- This item requires the vendor to provide unit costs on an hourly basis for labor and equipment. Such items would include a light pole knock down, identifying a ground fault or any other extraordinary mishaps.

Items 3, 4 and 5-Lamp Charges -This item requires the vendor to provide unit pricing for various lamps to relamp a light pole(s) to a requested wattage. These items would be utilized if it was determined that an increased or reduced wattage light bulb would better serve an intersection or residence.

Option 6-Aluminum Pole- Option 7-Concrete Pole-Option 8-Uni Duct

Occasionally the City of Darien receives petitioned requests for the installation of aluminum and concrete street lights. The light pole installation will be subject to an additional cost for uni-duct wiring, (**Option 8**) at a per a lineal foot unit price installed.

Option 9-Straighten Concrete Poles

Occasionally concrete light poles require straightening. This item requires excavation at the base of the pole, straightening, and backfilling.

The 2016/17 Budget calls out for the funding for the Street Light Maintenance Program from the following line items:

ACCOUNT NUMBER	ACCOUNT DESCRIPTION	FY 16/17 BUDGET	PROPOSED EXPENDITURE
01-30-4359	STREET LIGHT OPERATION & MAINTENANCE	\$ 50,000.00	\$ 50,000.00
01-30-4359	LIGHT POLE REPAIRS	\$40,000.00	\$40,000.00
01-30-4359	STREET LIGHT INSTALLATION	\$ 7,000.00	\$ 7,000.00
01-30-4359	STREET LIGHT R&R LENSES	\$ 5,000.00	\$ 5,000.00
TOTAL		\$ 102,000.00	\$ 102,000.00

Staff Recommendation

The Staff recommends approval of the contract extension through the attached resolution. The vendor has provided quality service to the City since 2012 and accepts the extension (See Attachment C).

Alternate Consideration

Not approving the street light maintenance contract.

Decision Mode

This item will be placed on the April 4, 2016 City Council agenda for formal consideration.

**CITY OF DARIEN PUBLIC WORKS
1702 PLAINFIELD ROAD
DARIEN, IL 60561**

Attachment A

SEALED BID: 2015-2017 Street Light Maintenance

OPENING DATE/TIME: March 12, 2015 @ 10:00 a.m.

		Rag's Electric Co., Inc.	Lyons Electric Non Responsive	Meade Electric
ITEM	DESCRIPTION			
	Part A - 2015	\$ 36,949.00	\$ 52,496.00	\$ 61,579.71
	Part B - 2015	\$ 598.00	\$ 1,092.00	\$ 895.71
	Total 2015	\$ 37,547.00	\$ 53,588.00	\$ 62,475.42
	Part A - 2016	\$ 38,030.00	\$ 54,071.88	\$ 63,916.07
	Part B - 2016	\$ 607.00	\$ 1,124.96	\$ 924.07
	Total 2016	\$ 38,637.00	\$ 55,196.84	\$ 64,840.14
	Part A - 2017	\$ 39,266.00	\$ 55,696.38	\$ 74,692.00
	Part B - 2017	\$ 623.00	\$ 1,158.50	\$ 6,327.00
	Total 2017	\$ 39,889.00	\$ 56,854.88	\$ 81,019.00
Total		\$ 116,073.00	\$ 165,639.72	\$ 208,334.56

OPTIONS TALLY

2015 - OPTION SUMMARY					
Company Name	Option 6 Aluminum Pole (Each)	Option 7 Concrete Pole (Each)	Option 8 Cost for Uniduct (Per Foot)	Option 9 Straightening of Concrete Poles (Each)	Total Option Price
Rags Electric	\$ 2,750.00	\$ 3,150.00	\$ 8.00	\$ 120.00	\$ 6,028.00
Meade Electric	\$ 4,650.00	\$ 5,200.00	\$ 27.25	\$ 1,000.00	\$ 10,877.25
Lyons Electric	\$ 4,000.00	\$ 4,350.00	\$ 17.00	\$ 300.00	\$ 8,667.00
2016 - OPTION SUMMARY					
Company Name	Option 6 Aluminum Pole (Each)	Option 7 Concrete Pole (Each)	Option 8 Cost for Uniduct (Per Foot)	Option 9 Straightening of Concrete Poles (Each)	Total Option Price
Rags Electric	\$ 2,850.00	\$ 3,300.00	\$ 8.00	\$ 120.00	\$ 6,278.00
Meade Electric	\$ 4,800.00	\$ 5,400.00	\$ 28.25	\$ 1,040.00	\$ 11,268.25
Lyons Electric	\$ 4,120.00	\$ 4,481.00	\$ 17.51	\$ 309.00	\$ 8,927.51
2017 - OPTION SUMMARY					
Company Name	Option 6 Aluminum Pole (Each)	Option 7 Concrete Pole (Each)	Option 8 Cost for Uniduct (Per Foot)	Option 9 Straightening of Concrete Poles (Each)	Total Option Price
Rags Electric	\$ 3,000.00	\$ 3,400.00	\$ 8.00	\$ 1.00	\$ 6,409.00
Meade Electric	\$ 49.75	\$ 5,600.00	\$ 29.00	\$ 1,080.00	\$ 6,758.75
Lyons Electric	\$ 4,244.00	\$ 4,616.00	\$ 18.04	\$ 318.27	\$ 9,196.31

LAMP TALLY

2015 PRICING	ITEM 3		ITEM 4		ITEM 5		TOTAL ITEMS 3,4,5
	High Pressure Sodium		Mercury Vapor		Mercury Halide		
	250W	400W	250W	400W	250W	400W	Lamp Charge
Rags Electric	\$ 12.00	\$ 13.00	\$ 12.00	\$ 13.00	\$ 12.00	\$ 13.00	\$ 75.00
Meade Electric	\$ 13.00	\$ 13.00	\$ 13.00	\$ 13.00	\$ 15.00	\$ 15.00	\$ 82.00
Lyons Electric	\$ 18.00	\$ 18.00	\$ 15.00	\$ 15.00	\$ 25.00	\$ 25.00	\$ 116.00
2016 PRICING	ITEM 3		ITEM 4		ITEM 5		TOTAL ITEMS 3,4,5
	High Pressure Sodium		Mercury Vapor		Mercury Halide		
	250W	400W	250W	400W	250W	400W	Lamp Charge
Rags Electric	\$ 12.00	\$ 13.00	\$ 12.00	\$ 13.00	\$ 12.00	\$ 13.00	\$ 75.00
Meade Electric	\$ 13.00	\$ 13.00	\$ 13.00	\$ 13.00	\$ 15.00	\$ 15.00	\$ 82.00
Lyons Electric	\$ 18.54	\$ 18.54	\$ 15.45	\$ 15.45	\$ 25.75	\$ 25.75	\$ 119.48
2017 PRICING	ITEM 3		ITEM 4		ITEM 5		TOTAL ITEMS 3,4,5
	High Pressure Sodium		Mercury Vapor		Mercury Halide		
	250W	400W	250W	400W	250W	400W	Lamp Charge
Rags Electric	\$ 12.00	\$ 13.00	\$ 12.00	\$ 13.00	\$ 12.00	\$ 13.00	\$ 75.00
Meade Electric	\$ 13.00	\$ 13.00	\$ 13.00	\$ 13.00	\$ 15.00	\$ 15.00	\$ 82.00
Lyons Electric	\$ 19.10	\$ 19.10	\$ 15.92	\$ 15.92	\$ 26.53	\$ 26.53	\$ 123.10

HOURLY RATES

2015 - HOURLY LABOR RATES

Company Name	Journeyman Straight Time	Journeyman Over Time	Helper Straight Time	Helper Over Time	Bucket Truck	Lift Truck	Pickup Truck	Auger/Backhoe	ITEM 2-Hourly Labor Rates
Rag's Electric	\$ 90.00	\$ 115.00	\$ 46.00	\$ 68.00	\$ 20.00	\$ 2.00	\$ 5.00	\$ 3.00	\$ 349.00
Meade Electric	\$ 114.22	\$ 186.22	\$ 65.21	\$ 100.06	\$ 38.00	\$ 47.00	\$ 19.00	\$ 43.00	\$ 612.71
Lyons Electric	\$ 110.00	\$ 160.00	\$ 75.00	\$ 110.00	\$ 55.00	\$ 55.00	\$ 25.00	\$ 60.00	\$ 650.00

2016 - HOURLY LABOR RATES

Company Name	Journeyman Straight Time	Journeyman Over Time	Helper Straight Time	Helper Over Time	Bucket Truck	Lift Truck	Pickup Truck	Auger/Backhoe	ITEM 2-Hourly Labor Rates
Rag's Electric	\$ 92.00	\$ 115.00	\$ 48.00	\$ 70.00	\$ 20.00	\$ 2.00	\$ 5.00	\$ 3.00	\$ 355.00
Meade Electric	\$ 118.78	\$ 193.66	\$ 67.82	\$ 104.06	\$ 39.00	\$ 48.00	\$ 20.00	\$ 44.00	\$ 635.32
Lyons Electric	\$ 113.30	\$ 164.80	\$ 77.25	\$ 113.30	\$ 56.65	\$ 56.65	\$ 25.75	\$ 61.80	\$ 669.50

2017 - HOURLY LABOR RATES

Company Name	Journeyman Straight Time	Journeyman Over Time	Helper Straight Time	Helper Over Time	Bucket Truck	Lift Truck	Pickup Truck	Auger/Backhoe	ITEM 2-Hourly Labor Rates
Rag's Electric	\$ 95.00	\$ 118.00	\$ 51.00	\$ 72.00	\$ 20.00	\$ 2.00	\$ 5.00	\$ 3.00	\$ 366.00
Meade Electric	\$ 123.50	\$ 201.40	\$ 70.50	\$ 108.22	\$ 40.00	\$ 49.00	\$ 21.00	\$ 45.00	\$ 658.62
Lyons Electric	\$ 116.70	\$ 169.74	\$ 79.57	\$ 116.70	\$ 58.35	\$ 58.35	\$ 26.52	\$ 63.65	\$ 689.58

COST TO REPAIR STREET LIGHT OUTAGE

2015 PRICING				
	ITEM 1	ITEM 2	ITEM 3	
Company Name	Cost of Street Light Repair	Cost to supply, remove, & replace ballast	Cost to supply, remove, & replace fuse kit	Total
Rag's Electric	\$ 137.00	\$ 206.00	\$ 40.00	\$ 383.00
Meade Electric	\$ 147.00	\$ 219.00	\$ 149.00	\$ 515.00
Lyons Electric	\$ 182.00	\$ 160.00	\$ 134.00	\$ 476.00
2016 PRICING				
	ITEM 1	ITEM 2	ITEM 3	
Company Name	Cost of Street Light Repair	Cost to supply, remove, & replace ballast	Cost to supply, remove, & replace fuse kit	Total
Rag's Electric	\$ 140.00	\$ 210.00	\$ 40.00	\$ 390.00
Meade Electric	\$ 152.75	\$ 227.75	\$ 155.00	\$ 535.50
Lyons Electric	\$ 187.46	\$ 164.80	\$ 138.02	\$ 490.28
2017 PRICING				
	ITEM 1	ITEM 2	ITEM 3	
Company Name	Cost of Street Light Repair	Cost to supply, remove, & replace ballast	Cost to supply, remove, & replace fuse kit	Total
Rag's Electric	\$ 145.00	\$ 215.00	\$ 40.00	\$ 400.00
Meade Electric	\$ 158.50	\$ 236.75	\$ 161.00	\$ 556.25
Lyons Electric	\$ 193.08	\$ 169.74	\$ 142.16	\$ 504.98

REPAIR COST ESTIMATES

Company Name	Year	Street Light Repair Total Item 1	Hourly Labor Rate Ranking Item 2	Lamp Charges Items 3,4,5	Option 6 Aluminum Pole	Option 7 Concrete Pole	Option 8 Cost for Uniduct	Option 9 Straighten Concrete Poles	LED Project	Total Unit Costs
Rag's Electric	2015	\$ 383.00	\$ 349.00	\$ 75.00	\$ 2,750.00	\$ 3,150.00	\$ 8.00	\$ 120.00	\$ 2,742.00	\$ 9,577.00
	2016	\$ 390.00	\$ 355.00	\$ 75.00	\$ 2,850.00	\$ 3,300.00	\$ 8.00	\$ 120.00	\$ -	\$ 7,098.00
	2017	\$ 400.00	\$ 366.00	\$ 75.00	\$ 3,000.00	\$ 3,400.00	\$ 8.00	\$ 1.00	\$ -	\$ 7,250.00
Meade Electric	2015	\$ 515.00	\$ 612.71	\$ 82.00	\$ 4,650.00	\$ 5,200.00	\$ 27.25	\$ 1,000.00	\$ 2,785.17	\$ 14,872.13
	2016	\$ 535.50	\$ 635.32	\$ 82.00	\$ 4,800.00	\$ 5,400.00	\$ 28.25	\$ 1,040.00	\$ -	\$ 12,521.07
	2017	\$ 556.25	\$ 658.62	\$ 82.00	\$ 49.75	\$ 5,600.00	\$ 29.00	\$ 1,080.00	\$ -	\$ 8,055.62
Lyons Electric	2015	\$ 476.00	\$ 650.00	\$ 116.00	\$ 4,000.00	\$ 4,350.00	\$ 17.00	\$ 300.00	\$ 2,915.00	\$ 12,824.00
	2016	\$ 490.28	\$ 669.50	\$ 119.48	\$ 4,120.00	\$ 4,481.00	\$ 17.51	\$ 309.00	\$ -	\$ 10,206.77
	2017	\$ 504.98	\$ 689.58	\$ 123.10	\$ 4,244.00	\$ 4,616.00	\$ 18.04	\$ 318.27	\$ -	\$ 10,513.97

Lisa Klemm

From: Dan Gombac
Sent: Monday, March 14, 2016 10:42 AM
To: Patrick A. Durkin
Cc: Lisa Klemm
Subject: RE: 2016-17 Street Light Contract Ext 1

Thank you Patrick.

Daniel Gombac
Director of Municipal Services
630-353-8106

To receive important information from the City of Darien sign up for our electronic newsletter:

DARIEN DIRECT CONNECT

Follow the link below and subscribing is simple!

<http://www.darien.il.us/Departments/Administration/CityNews.html>

From: Patrick A. Durkin [mailto:ragselectric@aol.com]
Sent: Friday, March 11, 2016 1:29 PM
To: Dan Gombac <dgombac@darienil.gov>
Subject: Re: 2016-17 Street Light Contract Ext 1

I am in agreement. Have a good weekend.

Pat Durkin
Rag's Electric
630-739-RAGS (7247) = Office
773-619-7640 = Cell

-----Original Message-----

From: Dan Gombac <dgombac@darienil.gov>
To: Rags Electric <ragselectric@aol.com>
Cc: Lisa Klemm <LKlemm@darienil.gov>; Bryon Vana <bvana@darienil.gov>
Sent: Fri, Mar 11, 2016 8:19 am
Subject: 2016-17 Street Light Contract Ext 1

Good Morning Pat:

Upon review of the street light contract, the City would like to exercise the 1st contract extension as per the unit prices, excluding the LED pricing.

Please let us know if you are in agreement.

Sincerely,

Daniel Gombac

Director of Municipal Services

630-353-8106

To receive important information from the City of Darien sign up for our electronic newsletter:

DARIEN DIRECT CONNECT

Follow the link below and subscribing is simple!

<http://www.darien.il.us/Departments/Administration/CityNews.htm>

1

RESOLUTION NO. _____

A RESOLUTION AUTHORIZING THE MAYOR AND CITY CLERK TO ENTER INTO A CONTRACT EXTENSION WITH RAG'S ELECTRIC COMPANY FOR THE ANNUAL 2016/17 STREET LIGHT MAINTENANCE. THE PROPOSED CONTRACT EXTENSION WOULD BE THE FIRST EXTENSION, YEAR 2 OF A THREE (3) YEAR CONTRACT

BE IT RESOLVED BY THE CITY COUNCIL OF THE CITY OF DARIEN, DU PAGE COUNTY, ILLINOIS, as follows:

SECTION 1: The City Council of the City of Darien hereby authorizes the Mayor and City Clerk to enter into a Contract Extension with Rag's Electric Company for the annual 2016/17 Street Light Maintenance. The proposed contract extension would be the first extension, year 2 of a three (3) year contract, a copy of which is attached hereto as "**Exhibit A**"

SECTION 2: This Resolution shall be in full force and effect from and after its passage and approval as provided by law.

PASSED BY THE CITY COUNCIL OF THE CITY OF DARIEN, DU PAGE COUNTY, ILLINOIS, this 4th day of April, 2016.

AYES: _____

NAYS: _____

ABSENT: _____

APPROVED BY THE MAYOR OF THE CITY OF DARIEN, DU PAGE COUNTY, ILLINOIS, this 4th day of April, 2016.

KATHLEEN MOESLE WEAVER, MAYOR

ATTEST:

JOANNE E. RAGONA, CITY CLERK

APPROVED AS TO FORM

CITY ATTORNEY

CITY OF DARIEN

CONTRACT

This Contract is made this 6th day of April, 2015 by and between the City of Darien (hereinafter referred to as the "CITY") and Rag's Electric, Inc. (hereinafter referred to as the "CONTRACTOR").

WITNESSETH

In consideration of the promises and covenants made herein by the CITY and the CONTRACTOR (hereinafter referred to collectively as the "PARTIES"), the PARTIES agree as follows:

SECTION 1: THE CONTRACT DOCUMENTS: This Contract shall include the following documents (hereinafter referred to as the "CONTRACT DOCUMENTS") however this Contract takes precedence and controls over any contrary provision in any of the CONTRACT DOCUMENTS. The Contract, including the CONTRACT DOCUMENTS, expresses the entire agreement between the PARTIES and where it modifies, adds to or deletes provisions in other CONTRACT DOCUMENTS; the Contract's provisions shall prevail. Provisions in the CONTRACT DOCUMENTS unmodified by this Contract shall be in full force and effect in their unaltered condition.

The Invitation to Bid

The Instructions to the Bidders

This Contract

The Terms and Conditions

The Bid as it is responsive to the CITY'S bid requirements

All Certifications required by the City

Certificates of Insurance

Performance and Payment Bonds as may be required by the CITY

SECTION 2: SCOPE OF THE WORK AND PAYMENT: The CONTRACTOR agrees to provide labor, equipment and materials necessary to provide the services as described in the CONTRACT DOCUMENTS and further described below:

Street Light Maintenance for the City of Darien right of ways and Private Property Commercial Parking Lots

(Hereinafter referred to as the "WORK") and the CITY agrees to pay the CONTRACTOR pursuant to the provisions of the Local Government Prompt Payment Act (50 ILCS 505/1 *et seq.*) the following amount for performance of the described unit prices.

SECTION 3: ASSIGNMENT: CONTRACTOR shall not assign the duties and obligations involved in the performance of the WORK which is the subject matter of this Contract without the written consent of the CITY.

SECTION 4: TERM OF THE CONTRACT: This Contract shall commence on the date of its execution. The WORK shall commence upon receipt of a Notice to Proceed and continue for the period specified. This Contract shall terminate upon completion of the WORK, but may be terminated by either of the PARTIES for default upon failure to cure after ten (10) days prior written notice of said default from the aggrieved PARTY. The CITY, for its convenience, may terminate this Contract with thirty (30) days prior written notice.

SECTION 5: INDEMNIFICATION AND INSURANCE: The CONTRACTOR shall indemnify and hold harmless the CITY, its officials, officers, directors, agents, employees and representatives and assigns, from lawsuits, actions, costs (including attorneys' fees), claims or liability of any character, incurred due to the alleged negligence of the CONTRACTOR, brought because of any injuries or damages received or sustained by any person, persons or property on account of any act or omission, neglect or misconduct of said CONTRACTOR, its officers, agents and/or employees arising out of, or in performance of any of the provisions of the CONTRACT DOCUMENTS, including any claims or amounts recovered for any infringements

of patent, trademark or copyright; or from any claims or amounts arising or recovered under the "Worker's Compensation Act" or any other law, ordinance, order or decree. In connection with any such claims, lawsuits, actions or liabilities, the CITY, its officials, officers, directors, agents, employees, representatives and their assigns shall have the right to defense counsel of their choice. The CONTRACTOR shall be solely liable for all costs of such defense and for all expenses, fees, judgments, settlements and all other costs arising out of such claims, lawsuits, actions or liabilities. The Contractor shall not make any settlement or compromise of a lawsuit or claim, or fail to pursue any available avenue of appeal of any adverse judgment, without the approval of the City and any other indemnified party. The City or any other indemnified party, in its or their sole discretion, shall have the option of being represented by its or their own counsel. If this option is exercised, then the Contractor shall promptly reimburse the City or other indemnified party, upon written demand, for any expenses, including but not limited to court costs, reasonable attorneys' and witnesses' fees and other expenses of litigation incurred by the City or other indemnified party in connection therewith. Execution of this Contract by the CITY is contingent upon receipt of Insurance Certificates provided by the CONTRACTOR in compliance with the CONTRACT DOCUMENTS.

SECTION 6: COMPLIANCE WITH LAWS: The bidder shall at all times observe and comply with all laws, ordinances and regulations of the federal, state, local and City governments, which may in any manner affect the preparation of bids or the performance of the Contract. Bidder hereby agrees that it will comply with all requirements of the Illinois Human Rights Act, 775 ILCS 5/1-101 et seq., including the provision dealing with sexual harassment and that if awarded the Contract will not engage in any prohibited form of discrimination in employment as defined in that Act and will require that its subcontractors agree to the same restrictions. The Contractor shall maintain, and require that its subcontractors maintain, policies of equal employment opportunity which shall prohibit discrimination against any employee or applicant for employment on the basis of race, religion, color, sex, national origin, ancestry, citizenship status, age, marital status, physical or mental disability unrelated to the individual's ability to perform the essential functions of the job, association with a person with a disability, or unfavorable discharge from military service. Contractors and all subcontractors shall comply with all requirements of the Act and of the Rules of the Illinois Department of Human Rights with regard to posting information on employees' rights under the Act. Contractors and all subcontractors shall place appropriate statements identifying their companies as equal opportunity employers in all advertisements for workers to be employed in work to be performed. Not less than the Prevailing Rate of Wages as found by the City of Darien or the Department of Labor shall be paid to laborers, workmen, and mechanics performing work under the Contract. If awarded the Contract, Contractor must comply with all provisions of the Illinois Prevailing Wage Act, including, but not limited to, providing certified payroll records to the Municipal Services Department. Contractor and subcontractors shall be required to comply with all applicable federal laws, state laws and regulations regarding minimum wages, limit on payment to minors, minimum fair wage standards for minors, payment of wage due employees, and health and safety of employees. Contractor and subcontractor are required to pay employees all rightful salaries, medical benefits, pension and social security benefits pursuant to applicable labor agreements and federal and state statutes and to further require withholdings and deposits therefore. The CONTRACTOR shall obtain all necessary local and state licenses and/or permits that may be required for performance of the WORK and provide those licenses to the CITY prior to commencement of the WORK if applicable.

SECTION 7: NOTICE: Where notice is required by the CONTRACT DOCUMENTS it shall be considered received if it is delivered in person, sent by registered United States mail, return receipt requested, delivered by messenger or mail service with a signed receipt, sent by facsimile or e-mail with an acknowledgment of receipt, to the following:

City of Darien
1702 Plainfield Road
Darien, IL 60561
Attn: Director of Municipal Services

SECTION 8: STANDARD OF SERVICE: Services shall be rendered to the highest professional standards to meet or exceed those standards met by others providing the same or similar services in the Chicagoland area. Sufficient competent personnel shall be provided who with supervision shall complete the services required within the time allowed for performance. The CONTRACTOR'S personnel shall, at all times present a neat appearance and shall be trained to handle all contact with City residents or City employees in a respectful manner. At the request of the Director of Municipal Services or a designee, the CONTRACTOR shall replace any incompetent, abusive or disorderly person in its employ.

SECTION 9: PAYMENTS TO OTHER PARTIES: The CONTRACTOR shall not obligate the CITY to make payments to third parties or make promises or representations to third parties on behalf of the CITY without prior written approval of the City Administrator or a designee.

SECTION 10: COMPLIANCE: CONTRACTOR shall comply with all of the requirements of the Contract Documents, including, but not limited to, the Illinois Prevailing Wage Act where applicable and all other applicable local, state and federal statutes, ordinances, codes, rules and regulations.

SECTION 11: LAW AND VENUE: The laws of the State of Illinois shall govern this Contract and venue for legal disputes shall be DuPage County, Illinois.

SECTION 12: MODIFICATION: This Contract may be modified only by a written amendment signed by both PARTIES.

FOR: THE CITY

FOR: THE CONTRACTOR

By: Kathleen Moesle Weaver

By: Patrick A. Durkin

Print Name: Kathleen Moesle Weaver

Print Name: Patrick A. Durkin

Title: Mayor

Title: President

Date: April 6, 2015

Date: 03/12/2015

II. - REQUIRED BID SUBMISSION DOCUMENTS

BIDDER SUMMARY SHEET

**STREET LIGHT MAINTENANCE FOR THE CITY OF DARIEN RIGHT OF WAY
AND PRIVATE PROPERTY COMMERCIAL PARKING LOTS-2015**

Firm Name: Rag's Electric, Inc.
Address: 7900 S. Cass Ave., Suite #180
City, State, Zip Code: Darien, IL 60561
Contact Person: Patrick Durkin
FEIN #: 20-501274
Phone: (630) 739-7247 Fax: (630) 739-7424
Mobile: (773) 619-7640
E-mail Address: ragselectric@aol.com

RECEIPT OF ADDENDA: The receipt of the following addenda is hereby acknowledged:

Addendum No. 1, Dated 03/09/2015

Addendum No. _____, Dated _____

Schedule of Prices for:

STREETLIGHT MAINTENANCE SERVICES PROPOSAL FOR STREET LIGHTS AND POLES LOCATED WITHIN THE RIGHT OF WAYS

Item No.	Items	Unit	Quantity	Unit Price	Total
2016 PRICING					
1	Total cost to repair Street Light Outage	Each	125	140	17,500
	Total cost to supply, remove and replace ballast	Each	20	210	4,200
	Total cost to supply, remove and replace fuse kit	Each	20	40	800
2	Hourly Labor Rates				
	Journeyman – Straight Time	HR	1	92	92
	Journeyman – Over Time	HR	1	115	115
	Helper – Straight Time	HR	1	48	48
	Helper – Over Time	HR	1	70	70
	Bucket Truck	HR	1	20	20
	Lift Truck	HR	1	2	2
	Pickup Truck	HR	1	5	5
	Auger/Backhoe	HR	1	3	3
3	Material Costs – High Pressure Sodium:				
	Brand:				
	250 Watt	Ea.	1	12	12
	400 Watt	Ea.	1	13	13
4	Material Costs – Mercury Vapor:				
	Brand:				
	250 Watt	Ea.	1	12	12
	400 Watt	Ea.	1	13	13
5	Material Costs – Mercury Halide:				
	Brand:				
	250 Watt	Ea.	1	12	12
	400 Watt	Ea.	1	13	13
6-option	Purchase and Installation of Street Light	Ea.	2	2,850	5,700
	Aluminum pole 25' height with 8' arm -				
7-option	Purchase and Installation of Street Light	Ea.	2	3,300	6,600
	Concrete pole 25' height with 8' arm -				
8-option	Unit cost for Uniduct (Material and Installation) Material 1 1/4" – XLP-USP with 3 #6 Copper Wires	Ft.	200	8.00	1,600
9-option	Straightening of Concrete Light Poles	Ea.	10	120	1,200
Part A Sub-Total					38,030.00

NOTE TO ALL CONTRACTORS: The bid tabulations will be based upon Total Cost of items 1, 2, 3, 4, 5, 6, 7, 8 and 9.

Schedule of Prices for:

LIGHT POLE MAINTENANCE SERVICES FOR PRIVATE PROPERTY COMMERCIAL PARKING LOTS

Item No.	Items	Unit	Quantity	Unit Price	Total
2016 PRICING					
1	Total cost to repair Street Light Outage	Ea.	1	140	140
2	Hourly Labor Rates				
	Journeyman – Straight Time	HR	1	92	92
	Journeyman – Over Time	HR	1	115	115
	Helper – Straight Time	HR	1	48	48
	Helper – Over Time	HR	1	70	70
	Bucket Truck	HR	1	20	20
	Lift Truck	HR	1	2	2
	Pickup Truck	HR	1	5	5
	Auger/Backhoe	HR	1	3	3
3	Material Costs – High Pressure Sodium:				
	Brand:				
	100 Watt	Ea.	1	10	10
	150 Watt	Ea.	1	10	10
	200 Watt	Ea.	1	12	12
	250 Watt	Ea.	1	12	12
4	Material Costs – Mercury Vapor:				
	Brand:				
	100 Watt	Ea.	1	10	10
	175 Watt	Ea.	1	12	12
	250 Watt	Ea.	1	12	12
5	Material Costs – Mercury Halide:				
	Brand:				
	100 Watt	Ea.	1	10	10
	175 Watt	Ea.	1	12	12
	250 Watt	Ea.	1	12	12
Part B Sub-Total				607	607

NOTE TO ALL CONTRACTORS: The bid tabulations will be based upon Total Cost of items 1, 2, 3, 4, and 5.

BUSINESS ORGANIZATION:

_____ Sole Proprietor: An individual whose signature is affixed to this bid.

_____ Partnership: Attach sheet and state full names, titles and addresses of all responsible principals and/or partners.

X Corporation: State of incorporation: Illinois

Provide a disclosure of all officers and principals by name and business address, date of incorporation and indicate if the corporation is authorized to do business in Illinois. In submitting this bid, it is understood that the City of Darien reserves the right to reject any or all bids, to accept an alternate bid, and to waive any informalities in any bid. In compliance with your Invitation to Bid, and subject to all conditions thereof, the undersigned offers and agrees, if this bid is accepted, to furnish the services as outlined.

<u> Rag's Electric Inc. </u>	<u> (Corporate Seal) </u>
Business Name	
<u>  </u>	<u> Patrick A. Durkin </u>
Signature	Print or type name
<u> President </u>	<u> 03/12/2015 </u>
Title	Date

AGENDA MEMO
Municipal Services
March 28, 2016

Issue Statement

Approval of the following resolutions as they relate to the City’s LED Streetlight Retrofit Project:

Approval of a resolution to except a proposal from Lake Shore Lighting LLC, for the purchase of LED Street Light Heads at a cost not to exceed \$187,160.

AND

Approval of a resolution to except the revised unit pricing from Rags Electric in an amount not to exceed \$55,680 for the removal of the existing street light heads and the installation of the new LED fixtures.

Background/History

On March 12, 2015 staff had received three sealed bids for the 2015/16 Street Light Maintenance Contract. Rags Electric is the awarded vendor for the City’s Street Light Maintenance Contract. The contract called out for an optional LED Conversion cost schedule.

In summary, the LED Conversion Project includes the following:

1. Removal of the existing fixture
2. Disposal of the existing fixture
3. Purchase and Installation of the following *571 LED Streetlight heads as follows:

**TYPE	MANUFACTURER	QUANTITY	PART NUMBER
A	EYE LIGHTING	17	LES-37W-333-840-HWD W/ 10KA SURGE SUPPRESSOR /TERMINAL BLOCK
A-1	LEOTEK	300	HSS GCM 40 (HOUSE SIDE SHIELD FOR TYPE A)
B	EYE LIGHTING	61	LES-57W 333-840-HWD W/10KA SURGE / TERMINAL BLOCK
C	EYE LIGHTING	14	P-L4-45-5-7-U-Y-N-R-E1
D	LEOTEK	422	GCM2-40F-MV-NW-2-GY-1A
E	LEOTEK	57	GC2-80F-MV-NW-3-GY-1A

****Type-Refers to Map Location (not included)**

*Total street light inventory is currently at 571 fixtures. Pending field conditions the inventory will be updated. Each fixture shall carry a 10-year warranty and Rags Electric shall provide a one-year installation warranty. The installation warranty shall ensure the City that the vendor has secured the fixture per the lighting manufacturer specs and is structurally secured to the existing pole/mast arm.

The City applied for the following two grants:

1. Illinois Clean Energy Grant #7370 for \$25,000 Approved on April 30, 2015, see Attachment A (6 pages). An extension was granted on March 7, 2016. The project must be completed by July 31, 2016, see attached correspondence labeled as Attachment B. The City's cost must be in the minimal amount of \$62,500 to meet the requirements of the grant.
2. Illinois Department of Commerce and Economic Opportunity's (DCEO) 2015-2016 Illinois Energy Now Public Sector Energy Efficiency Program Darien LED Streetlight Project 9092, Approved for \$105,000, see attached correspondence labeled as Attachment C (4 pages). Please note: This grant has not been released to date, and is pending approval of the state budget.

In preparation of the 2016-17 Budget, Staff reached out to the lighting representative and requested a review of the fixture pricing as presented within the street Lighting bid tally. The manufacturer's representative, Lake Shore Lighting, LLC, was able to secure additional discounting provided that all the fixtures were purchased at one time.

Attached and Labeled as Attachment D and Attachment E (13 pages) are the fixture pricing as per the 2015 bid tally and the renegotiated pricing directly from the manufactures representative.

The City staff also reached out to the City's awarded street light vendor, Rags Electric, and requested to negotiate the removal and installation unit pricing from \$49.00 to \$40.00 per item. The vendor has agreed to the request and attached as Attachment F is the bid tally and renegotiated pricing.

Once the project is completed, it is conservatively estimated that the return on investment is approximately 7.3 years. Majority of the street light fixtures are unmetered and billed under a Rate 25 Schedule. The City's current street light inventory has a vast range of bulbs that average approximately 200 watts. The vendor will be required to inventory every bulb being replaced and the city will forward the inventory to Com Ed with the LED Head replacement. Com Ed and Lakeshore Lighting will verify the revised power consumption and the rates will be revised. It is estimated that there will be an annual \$15,000 energy cost savings. The maintenance costs for the light outages will also be reduced by approximately \$12,000 annually.

The 2016/17 Budget calls out for the funding for the Street Light Maintenance Program from the following line items:

ACCOUNT NUMBER	ACCOUNT DESCRIPTION	FY 16/17 BUDGET	PROPOSED EXPENDITURE
25-35-4815	STREET LIGHT LED RETROFIT PROJECT	\$ 250,000.00	\$ 242,840.00
APPROVED GRANT	ILLINOIS CLEAN ENERGY	\$ 25,000.00	(\$ 25,000.00)
TOTAL COST			\$217,840.00
*GRANT PENDING	DCEO-Illinois Department of Commerce and Economic Opportunity's	\$105,000.00	(\$105,000.00)
TOTAL		N/A	\$ 112,840.00

* Pending State Budget approval by March 31, 2016. If State Budget is not approved by said date the grant will require resubmission, see Attachment C from the State of Illinois. Please note there is no guarantee that the DCEO grant will be approved.

Staff Recommendation

The Staff recommends approval of the attached resolutions.

Alternate Consideration

Not approving the project.

Decision Mode

This item will be placed on the April 4, 2016 City Council agenda for formal consideration.



April 30, 2015

Mr. Michael Griffith
Senior Planner
City of Darien
1702 Plainfield Road
Darien, IL 60561

Dear Mr. Griffith:

We are very pleased to inform you that the Illinois Clean Energy Community Foundation has approved a grant of \$25,000 to the City of Darien for energy efficient upgrades to lighting systems in your facilities.

Thank you for your leadership in demonstrating the value of investing in energy efficiency for your community: enhancing lighting quality, saving money, and improving the environment.

The attached grant agreement defines the terms and conditions of the grant.

To accept the grant, please review, sign and return the grant agreement electronically to the Foundation as soon as possible and no later than one month from today. Please keep a copy of the grant agreement for your records.

FAILURE TO DO SO MAY RESULT IN THE TERMINATION OF YOUR GRANT.

The Foundation requires grantees to submit grant requirements electronically. Your grant agreement, interim report, and other applicable grant-related documentation should be uploaded via the "Requirements" section of your online account. You can access your account by logging in at https://www.grantrequest.com/SID_325/?SA=AM. Be sure to provide your log-in credentials to others who may be managing these requirements.

On behalf of the Foundation's Board of Trustees and staff, we would like to extend our best wishes for the success of this project.

Sincerely,

A handwritten signature in black ink that reads "Dennis F. O'Brien".

Dennis F. O'Brien
Executive Director



April 30, 2015

Mr. Michael Griffith
Senior Planner
City of Darien
1702 Plainfield Road
Darien, IL 60561

Re: **Request ID: 7370**
City of Darien LED Streetlight
Upgrade - Revised Application

Dear Mr. Griffith:

The Illinois Clean Energy Community Foundation ("the Foundation") is awarding a grant of **\$25,000** to the City of Darien ("the Grantee") for the above-referenced project.

This letter defines the terms and conditions of the grant and constitutes the grant agreement ("the Agreement") between the Foundation and the Grantee. Please read it carefully. ***If the Grantee agrees to the terms and conditions in the Agreement, please return a complete counter-signed copy of the Agreement no later than one month from today. Failure to do so may result in the termination of your grant.*** Contact the Foundation if you have any questions.

Duration and Payment of Grant

This grant is to be used during the period **May 1, 2015** through **April 30, 2016** (the "Grant Period"). Upon satisfactory completion of the Project as defined herein, the Foundation will make a single payment to the Grantee based on the number of annual kilowatt hours of electricity reduced as a result of the Project as completed, but not more than \$25,000 or 40% of the total resulting cost of the project. If the resulting kilowatt hour reduction is less than 0.00 kilowatt hours, as estimated in the application materials submitted to the Foundation by the Grantee, the amount of the grant may be reduced on a pro-rated basis to reflect the actual reduction. The grant amount will not be increased in the event that the Project yields a greater kilowatt hour reduction than estimated in the grant application.

The Foundation reserves the right to suspend, modify or cancel any payments that might otherwise be due under this grant, to require a refund of any unexpended grant funds or both, if:

1. such action is necessary to comply with any applicable law or regulation;
2. the Grantee has used the grant funds for purposes other than as described in the Agreement or otherwise violated any part of the Agreement; and/or
3. the Grantee's performance under the grant has not been satisfactory.

The Foundation's judgment on these matters will be final and binding.

Purpose and Use of Grant

This grant is for the City of Darien LED Streetlight Upgrade - Revised Application (the "Project") described in the Project proposal and budget submitted to the Foundation by the Grantee and dated March 12, 2015. The Grantee confirms that this grant will be used solely for the specific tax-exempt purposes described in the Project proposal and budget and no substantial variance will be made without the Foundation's prior written approval.

The Grantee also confirms that the Project is under its complete control and that it has and will exercise control over the process of selecting any vendors, contractors or consultants involved in the Project. The Grantee and the Foundation are not partners or joint venturers with respect to each other.

Furthermore, the Grantee agrees that funds from this grant will be used exclusively for tax exempt purposes as described in Section 501(c) (3) of the Internal Revenue Code and will not be used for any activities prohibited by law, including, without limitation, attempting to influence legislation or participating in any political campaign on behalf of any candidate for public office. The Grantee agrees that it and its employees, agents and sub-contractors will comply with all applicable federal, state, county and local laws, ordinances, regulations and codes in the performance of the Grantee's obligations under this Agreement.

Reporting Requirements

An **Interim Report** shall be submitted 6 months after the start of the grant period. The Interim Report shall include an update on project activity including construction – if started. If construction has not started 6 months from the date of this grant award, a detailed explanation must be provided that includes an update on project financing and expected construction start.

If the term of the grant extends beyond the grant expiration date due to substantial delays in project construction and completion, additional Interim Reports may be required if deemed necessary by the Foundation. In such circumstances, additional report(s) should be provided in six month increments after the initial Interim Report is submitted.

Upon completion of the Project to the Grantee's satisfaction, the Grantee shall provide the Foundation with the various documents identified in Exhibit A attached hereto (the "Grantee Documents Required for Payment") as part of the Final Report. Promptly upon the Foundation's receipt of the Grantee Documents Required for Payment in form and substance satisfactory to the Foundation, the Foundation will send to the Grantee a check in the amount specified in the Duration and Payment of Grant section of this Agreement.

Publicity

The Foundation believes it is important that many organizations and individuals in Illinois learn about the Project and the ways it benefits the public. Accordingly, the Foundation strongly encourages the Grantee to publicize the receipt of this grant and the results of the Project.

The Grantee agrees to share with the Foundation a draft of any press release or public announcement of the grant prior to distributing the release or announcement and to provide the Foundation with clippings of resulting media coverage.

The Grantee also agrees to allow the Foundation to publicize the Grantee as a grant recipient and to use the name and description of the Project and photographs or other audiovisual representations of subjects related to the Project.

Maintenance of Records and Evaluation

The Grantee is responsible for maintaining adequate financial records regarding use of the grant funds, consistent with generally accepted accounting principles.

The Grantee agrees to cooperate fully in any evaluation of this grant and/or the Project that the Foundation may conduct. Such an evaluation may include a visit from Foundation staff or consultants, interviews with Project participants, a review of financial and other records about the Project maintained by the Grantee and/or similar investigative activities.

Confirmation of Tax-Exempt Status and Good Standing

The Grantee confirms that it is currently a unit of government or a nonprofit organization exempt from federal income tax under Section 501(c)(3) of the Internal Revenue Code and is not a private foundation under Section 509(a) of the Internal Revenue Code. **If the Grantee is not a unit of government, it agrees to submit with the signed Agreement written evidence of its tax-exempt, non-private foundation status if it has not previously provided such evidence to the Foundation.**

The Grantee further confirms that it is currently in good standing with appropriate state government agencies. If requested by the Foundation, the Grantee agrees to provide written evidence of its good standing.

If there is any change in the Grantee's tax exempt status or good standing during this grant, the Grantee agrees to immediately notify the Foundation of that change.

Acceptance of Terms and Conditions of Agreement

If the Grantee agrees to the terms and conditions in the Agreement, please return to the Foundation one complete copy of this letter signed by an authorized representative of the Grantee in the space provided below. For future reference, please retain a copy of the Agreement in your files. This grant award may be withdrawn if the Foundation has not received a counter-signed copy of the Agreement within one month from the date of this letter.

Sincerely,

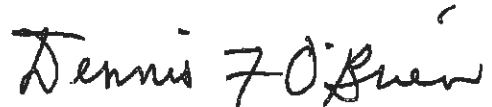

Dennis F. O'Brien
Executive Director

Attachment: Exhibit A – Grantee Documents Required for Payment

The Grantee acknowledges that relevant organization executives and Project personnel have read and understand the Agreement, that its terms and conditions are acceptable to the Grantee and that the Grantee will comply with those terms and conditions.

Grantee City of Darien
(This must be the legal name of the organization accepting the grant and it must have federal tax-exempt status.)

Name of Authorized Signer for the Grantee Bryon D VANA

Title of Signer City Administrator

Authorized Signature B D Va
(This must be an original signature of an authorized representative of the Grantee.)

Date Signed 5-4-15



Illinois Clean Energy

community foundation

2 North LaSalle Street • Suite 1140 • Chicago IL 60602
312.372.5191 • fax 312.372.5190 • www.IllinoisCleanEnergy.org

Exhibit A

Grantee Documents Required for Payment

The Foundation requires grantees to submit grant requirements electronically. Your grant agreement, interim report, and other applicable grant-related documentation should be uploaded via the "Requirements" section of your online account. You can access your account by logging in at https://www.grantrequest.com/SID_325/?SA=AM. Be sure to provide your log-in credentials to others who may be managing these requirements.

DOCUMENTS REQUIRED IMMEDIATELY

To accept the grant offered by the Foundation, the Grantee must return a complete, counter-signed copy of the Grant Agreement within one month from the date of this letter. Please keep a copy of the Agreement for your records.

DOCUMENTS REQUIRED UPON PROJECT COMPLETION

Upon completion of the Lighting Upgrade Project to the Grantee's satisfaction, the Grantee must send and upload the Foundation a signed letter on organization letterhead that:

1. confirm the Grantee's acceptance of the Project system hardware and installation as complete and satisfactory; and
2. request that the grant be paid, specifying the exact amount requested.

As attachments to that letter, the Grantee must provide the following documentation:

3. a detailed **updated** list of the quantity(ies) and type(s) of all lighting equipment removed and new/retrofit systems installed as part of the Project; (see notes below)
4. a copy of the final itemized invoice(s) from and/or check(s) issued to all vendors involved in the Project, showing amounts already paid and amounts still owed; this may also include a summary of the hours and total costs of any in-house labor used to complete the Project; in sum, these documents should reflect the total resulting cost of the Project *for each facility upgraded*; and
5. a summary **updated** calculation of the electricity reduction, in kilowatt hours, resulting from the Project, as completed, *for each facility upgraded*. (see the following notes)

Notes:

- a. The wattage savings due to work that is not eligible to be supported with this grant, such as upgrades the replacement of incandescent bulbs with "screw-in" compact fluorescent bulbs, should NOT be included in this calculation).
- b. Regarding documentation requirements #3 and #5; updated information reflecting actual lighting upgrade work performed and corresponding reduction in watts or kilowatts must be provided. A copy of documentation provided with the original funding application will not be accepted as evidence of compliance with these requirements.
- a.



March 10, 2016

Mr. Daniel Gombac
Municipal Services Director
City of Darien
1702 Plainfield RD
Darien, IL 60561

Re: **Request ID: 7370**
City of Darien LED Streetlight
Upgrade - Revised Application

Dear Mr. Gombac:

The Foundation has received your request for an extension of the grant period for the above referenced project.

The Illinois Clean Energy Community Foundation accepts the proposed change to the terms of the grant for that project. The grant period is now **May 1, 2015** through **July 31, 2016**. All other terms and conditions of the grant, as defined in the grant agreement dated April 30, 2015 and accepted by Bryon Vana, City Administrator, on May 4, 2015 continue in full force and effect. If you have any further questions about this grant, please contact Nick Poplawski at (312) 372-5191.

Sincerely,

A handwritten signature in black ink that reads "Dennis F. O'Brien".

Dennis F. O'Brien
Executive Director

Dan Gombac

From: Habibi, Johnny <Johnny.Habibi@illinois.gov>
Sent: Friday, March 11, 2016 9:33 AM
To: Dan Gombac
Cc: Bryon Vana; 'nbetzold@lakeshorelight.com'; Lisa Klemm
Subject: RE: DCEO Pre-Application - Darien LED Streetlight Project 9092

Then will have to move for next budget year FY17, & the app has been approved, then a new application will have to be resubmitted. We will use the documents (cut sheets, maps, ...), & the review will be easier this time since it was reviewed before.

From: Dan Gombac [mailto:dgombac@darienil.gov]
Sent: Friday, March 11, 2016 9:28 AM
To: Habibi, Johnny
Cc: Bryon Vana; 'nbetzold@lakeshorelight.com'; Lisa Klemm
Subject: RE: DCEO Pre-Application - Darien LED Streetlight Project 9092

Thanks Johnny.

Just to clarify, if there is no budget by the end of this month, the grant becomes null and void??

Daniel Gombac
Director of Municipal Services
 630-353-8106

To receive important information from the City of Darien sign up for our electronic newsletter:

DARIEN DIRECT CONNECT

Follow the link below and subscribing is simple!

<http://www.darien.il.us/Departments/Administration/CityNews.html>

From: Habibi, Johnny [mailto:Johnny.Habibi@illinois.gov]
Sent: Friday, March 11, 2016 9:23 AM
To: Dan Gombac <dgombac@darienil.gov>
Cc: Bryon Vana <bvana@darienil.gov>; 'nbetzold@lakeshorelight.com' <nbetzold@lakeshorelight.com>; Lisa Klemm <LKlemm@darienil.gov>
Subject: RE: DCEO Pre-Application - Darien LED Streetlight Project 9092

Hi Dan,

The application 9092 is approved for the amount of \$105,663.50. Rebate Agreement document has been prepared, but we can't give a Notice to Proceed letter or give this rebate \$ amount since there is no State of Illinois budget for FY16, we are still waiting for it to be enacted. Therefore, unless there is a budget for FY16, then the grant will be paid up by 5/31/2016. The City of Darien can move ahead with the project but it will be at its own risk in regards to getting the rebate \$ amount described above, in case there is no budget before 3/31/2016. I hope this answers your questions.

Best Regards.

Johnny Habibi PE, CEM

Mechanical Engineer III

Illinois Dept. of Commerce & Economic Opportunity (DCEO)

Illinois Energy Office Web site: <http://www.illinoisenergy.org/>

500 East Monroe Street (Ridgley Building 12th Floor)

Springfield, IL 62701

1.217. 785.2772 (Voice)

1.217. 785.2618 (Fax)

e-mail: johnny.habibi@illinois.gov

Web: www.illinois.gov/dceo



Illinois
Department of Commerce
& Economic Opportunity
OFFICE OF ENERGY & RECYCLING
Bruce Rauner, Governor

CONFIDENTIALITY NOTICE: The information contained in this communication is confidential, may be attorney-client privileged or attorney work product, may constitute inside information or internal deliberative staff communication, and is intended only for the use of the addressee. Unauthorized use, disclosure or copying of this communication or any part thereof is strictly prohibited and may be unlawful. If you have received this communication in error, please notify the sender immediately by return e-mail and destroy this communication and all copies thereof, including all attachments. Receipt by an unintended recipient does not waive attorney-client privilege, attorney work product privilege, or any other exemption from disclosure.

From: Dan Gombac [<mailto:dgombac@darienil.gov>]

Sent: Friday, March 11, 2016 9:09 AM

To: Habibi, Johnny

Cc: Bryon Vana; 'nbetzold@lakeshorelight.com'; Lisa Klemm

Subject: RE: DCEO Pre-Application - Darien LED Streetlight Project 9092

Good morning Johnny:

I wanted to follow up regarding our grant, Darien LED Streetlight Project 9092.

1. Has there been any updates regarding the funding of said grant?
2. Should the funding be approved, and the City's moves ahead with the project, will the grant be retroactive and up to how long?
3. Could you please forward a copy of the proposed grant funding we would be eligible for?

Sincerely,

Daniel Gombac

Director of Municipal Services

630-353-8106

To receive important information from the City of Darien sign up for our electronic newsletter:

DARIEN DIRECT CONNECT

Follow the link below and subscribing is simple!

<http://www.darien.il.us/Departments/Administration/CityNews.html>

From: Dan Gombac
Sent: Tuesday, September 08, 2015 11:36 AM
To: nbetzold@lakeshorelight.com
Cc: Bryon Vana <bvana@darienil.gov>
Subject: RE: DCEO Pre-Application - Darien LED Streetlight Project 9092

Thanks Nick

Daniel Gombac
Director of Municipal Services
630-353-8106

To receive important information from the City of Darien sign up for our electronic newsletter:

DARIEN DIRECT CONNECT

Follow the link below and subscribing is simple!

<http://www.darien.il.us/Departments/Administration/CityNews.html>

From: nbetzold@lakeshorelight.com [<mailto:nbetzold@lakeshorelight.com>]
Sent: Tuesday, September 08, 2015 11:33 AM
To: Dan Gombac
Subject: Fwd: DCEO Pre-Application - Darien LED Streetlight Project 9092

Sent from my iPhone

Begin forwarded message:

From: CEO.Illinois energy <illinois.energy@illinois.gov>
Date: September 8, 2015 at 10:51:44 AM CDT
To: Nick Betzold <nbetzold@lakeshorelight.com>
Cc: "Habibi, Johnny" <Johnny.Habibi@illinois.gov>
Subject: RE: DCEO Pre-Application - Darien LED Streetlight Project 9092

Thank you for your application to the Illinois Department of Commerce and Economic Opportunity's (DCEO) 2015-2016 Illinois Energy Now Public Sector Energy Efficiency Program. We are processing your application and will issue notices to proceed when the Illinois State Budget has been passed. For all further communication regarding your application, please reference project 9092 and contact the DCEO project manager.

This project has been assigned to:

Johnny Habibi
johnny.habibi@illinois.gov
217/785-2772

Lisa Teubner
DCEO
Illinois Energy Office
500 E Monroe R-12
Springfield, IL 62701
217/785-7440
Lisa.teubner@illinois.gov

From: Nick Betzold [<mailto:nbetzold@lakeshorelight.com>]
Sent: Sunday, September 06, 2015 12:13 AM
To: CEO.Illinois energy
Cc: Dan Gombac
Subject: DCEO Pre-Application - Darien LED Streetlight Project

Good Evening,

Attached is the 2015 DCEO Pre-Application and signed Section 2, ComEd Bills, & Spec Sheets (saved as - Darien DCEO Pre-App PART 2) for the City of Darien LED Streetlight Project.

This project has missed 2 previous DCEO cuts when the program has ran out of money and has been years in the making. This project has already been bid out and awarded. The only thing holding the City of Darien back from completing the project is the receipt of a DCEO acceptance letter or some sort of official letter stating the City of Darien has funds set aside.

Please confirm that you have received this email, and let me know if you need any additional information or have any questions.

Thanks!

Best Regards,

Nick Betzold



Office: (844) 525-3746
Direct: (847) 989-5843
Fax: (847) 387-3950

Email: nbetzold@lakeshorelight.com

www.LakeShoreLight.com

The information in this email is confidential and may be legally privileged. It is intended solely for the addressee. Access to this email by anyone else is unauthorized. Any disclosure, copying, distribution or any action taken or omitted to be taken in reliance on it, is prohibited and may be unlawful. If you are not the intended addressee please contact the sender and dispose of this e-mail.



CONFIDENTIALITY NOTICE: The information contained in this communication is confidential, may

LED RETROFIT PROGRAM

PROPOSED PROGRAM WITH RENEGOTIATED PRICING									
2015 PRICING-BID TALLY MARCH 12, 2015									
	ITEM 1	ITEM 2	ITEM 3	ITEM 4	ITEM 5	ITEM 6	ITEM 7	ITEM 8	
Company Name	Eye Lighting LES-37W-333-840-HWD	Eye Lighting LES-57W-443-840-HWD	Eye Lighting PD-L4-40-5-7-U-Y-G-R-E1	Leotek Hss GCM 40	Leotek GCM2-40F-MV-NW-2-GY-1A	Leotek GC2-80F-MV-NW-3-GY-1A	Installation Costs	Cost to remove existing light head fixture	Total
Rag's Electric	\$ 444.00	\$ 504.00	\$ 794.00	\$ 18.00	\$ 312.00	\$ 571.00	\$ 49.50	\$ 49.50	\$ 2,742.00
Revised Pricing	\$ 393.00	\$ 438.00	\$ 724.00	\$ 18.00	\$ 256.00	\$ 449.00	\$ 40.00	\$ 40.00	\$ 2,358.00
Meade Electric	\$ 450.75	\$ 511.32	\$ 800.80	\$ 18.37	\$ 315.73	\$ 578.20	\$ 63.00	\$ 47.00	\$ 2,785.17
Lyons Electric	\$ 465.00	\$ 528.00	\$ 830.00	\$ -	\$ 335.00	\$ 597.00	\$ 140.00	\$ 20.00	\$ 2,915.00

QUANTITY BREAKDOWN-BID TALLY MARCH 12, 2015 UNIT PRICING									
QUANTITY	ITEM 1	ITEM 2	ITEM 3	ITEM 4	ITEM 5	ITEM 6	ITEM 7	ITEM 8	Total
	Eye Lighting LES-37W-333-840-HWD	Eye Lighting LES-57W-333-840-HWD	Eye Lighting P-L4-45-5-7-U-Y-N-R-E1	Leotek Hss GCM 40	Leotek GCM2-40F-MV-NW-2-GY-1A	Leotek GC2-80F-MV-NW-3-GY-1A	Installation Costs	Cost to remove existing light head fixture	Total
198					\$ 61,776.00				\$ 61,776.00
224					\$ 61,776.00				\$ 61,776.00
45						\$ 25,695.00			\$ 25,695.00
12						\$ 6,852.00			\$ 6,852.00
17	\$ 7,548.00								\$ 7,548.00
61		\$ 30,744.00							\$ 30,744.00
14			\$ 11,116.00						\$ 11,116.00
571							\$ 28,264.50	\$ 28,264.50	\$ 56,529.00
BID TALLY COST									\$ 262,036.00

REVISED PROGRAM SUMMARY-WITH RE-NEGOTIATED PRICING									
QUANTITY	ITEM 1	ITEM 2	ITEM 3	ITEM 4	ITEM 5	ITEM 6	ITEM 7	ITEM 8	Total
	Eye Lighting LES-37W-333-840-HWD	Eye Lighting LES-57W-333-840-HWD	Eye Lighting P-L4-45-5-7-U-Y-N-R-E1	Leotek Hss GCM 40	Leotek GCM2-40F-MV-NW-2-GY-1A	Leotek GC2-80F-MV-NW-3-GY-1A	Installation Costs	Cost to remove existing light head fixture	Total
198					\$ 50,688.00				\$ 50,688.00
224					\$ 57,344.00				\$ 57,344.00
45						\$ 20,205.00			\$ 20,205.00
12						\$ 5,388.00			\$ 5,388.00
17	\$ 6,681.00								\$ 6,681.00
61		\$ 26,718.00							\$ 26,718.00
14			\$ 10,136.00						\$ 10,136.00
571									\$ 10,136.00
MATERIAL COSTS									\$ 177,160.00
CONTINGENCY-MATERIAL									\$ 10,000.00
TOTAL MATERIAL COSTS									\$ 187,160.00
CONTINGENCY-LABOR									\$ 22,840.00
TOTAL LABOR COSTS									\$ 22,840.00
TOTAL PROJECT COST									\$ 242,840.00

ROI	Energy Savings	Maintenance	Total
Annual Cost Savings	\$ 15,000.00	\$ 12,000.00	\$ 27,000.00
Project Cost Material and Labor	\$ 222,840.00		
Contingency	\$ 20,000.00		
Total Cost	\$ 242,840.00		
Illinois Clean Energy Grant	\$ 25,000.00		
Adjusted Project Cost	\$ 197,840.00		
No of years to recoup costs	7.33		

Dan Gombac

From: Nick Betzold <nbetzold@lakeshorelight.com>
Sent: Tuesday, February 02, 2016 5:25 PM
To: Dan Gombac
Subject: Revised Pricing for LED Streetlights
Attachments: Revised Leotek Streetlight Pricing - Darien.pdf

Hi Dan,

Please see attachments for revised pricing for the Leotek Streetlights. We're quite a bit lower than before. We can do the entire project including install with Rags without going out to bid via TIPS USA. I also put in pricing for the Leotek GCM2-30F as an alternate for the GCM2-40F which is a bit cheaper and slightly less light than the GCM2-40F.

Let me know if you have any questions.

Thanks Dan.

Best Regards,

Nick Betzold

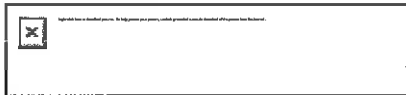

Office: (844) 525-3746
Direct: (847) 989-5843
Fax: (847) 387-3950

Email: nbetzold@lakeshorelight.com

www.LakeShoreLight.com

The information in this email is confidential and may be legally privileged. It is intended solely for the addressee. Access to this email by anyone else is unauthorized. Any disclosure, copying, distribution or any action taken or omitted to be taken in reliance on it, is prohibited and may be unlawful. If you are not the intended addressee please contact the sender and dispose of this e-mail.





Estimate

Lakeshore Lighting, LLC
 1204 E Central Road
 Arlington Heights, IL 60005

Date	3/21/2016
Estimate #	15247
Account #	

Name / Address
City of Darien Dan Gombac 1702 Plainfield Rd Darien, IL 60561

Project	Terms
Darien LED Streetlights	50/50 Due on Receipt

Type	Vendor	Description	Rate	Qty	MPN	Total
GCM2-2	LEOTEK	LEOTEK, GCM2 SERIES, 40 LED, 120-277V, 4000K CCT, TYPE 2 OPTIC (2 LANE ROADWAYS, GRAY, 1A	256.00	198	GCM2-40F-MV-NW-2-GY-1A	50,688.00
GCM2-3	LEOTEK	LEOTEK, GCM2 SERIES, 40 LED, 120-277V, 4000K CCT, TYPE 3 OPTIC (INTERSECTIONS & CUL DE SACS), GRAY, 1A	256.00	224	GCM2-40F-MV-NW-3-GY-1A	57,344.00
GC2-3	LEOTEK	LEOTEK, GC2 SERIES, 80 LED, 120-277V, 4000K CCT, TYPE 3 OPTIC, GRAY, 1A	449.00	45	GC2-80F-MV-NW-3-GY-1A	20,205.00
GC2-2	LEOTEK	LEOTEK, GC2 SERIES, 80 LED, 120-277V, 4000K CCT, TYPE 2 OPTIC, GRAY, 1A	449.00	12	GC2-80F-MV-NW-2-GY-1A	5,388.00
DPT-B & DPT-C	EYE LIGHTING	EYE LIGHTING, 37W LED RETROFIT KIT, 3-SIDES POPULATED, 4000K, HARDWIRED, 120-277V, STANDARD TID (Darien DPT-B & DPT-C)	393.00	17	LES-37W333-840-HWD-XXXX-UNV-3	6,681.00
DPT-A	EYE LIGHTING	EYE LIGHTING, 57W LED POST TOP RETROFIT KIT, 4 SIDES POPULATED, 4000K, HARDWIRED, 120-277V, STANDARD TID, (Darien DPT-A)	438.00	61	LES-57W443-840-HWD-XXXX-UNV-3	26,718.00

	Total
--	--------------

Toll Free	Fax #	Web Site	Rep	Email
847-989-5843	847-387-3950	www.lakeshorelight.com	NB	nbetzold@lakeshorelight.com



Lakeshore Lighting, LLC
 1204 E Central Road
 Arlington Heights, IL 60005

Estimate

Date	3/21/2016
Estimate #	15247
Account #	

Name / Address
City of Darien Dan Gombac 1702 Plainfield Rd Darien, IL 60561

Project	Terms
Darien LED Streetlights	50/50 Due on Receipt

Type	Vendor	Description	Rate	Qty	MPN	Total
PTN	EYE LIGHTING	EYE LIGHTING, NEW DECORATIVE POST TOP LED FIXTURE, DECORATIVE FITTER, 4,000 LUMENS, TYPE 5 OPTIC, 120-277V, ACRYLIC LENS, GRAY, INTERNAL PHOTOCELL RECEPTACLE, TERMINAL BLOCK #2 - #14 AWG WIRE LEADS, (Darien PTN)	724.00	14	PD-L4-40-5-7-U-Y-G-R-E1	10,136.00
		Sales Tax	7.50%			0.00

--

Total	\$177,160.00
--------------	--------------

Toll Free	Fax #	Web Site	Rep	Email
847-989-5843	847-387-3950	www.lakeshorelight.com	NB	nbezold@lakeshorelight.com

GreenCobra™ Midsize LED Street Light GCM

Luminaire Data

Weight 10 lbs [4.6 kg]
EPA 0.44 ft²

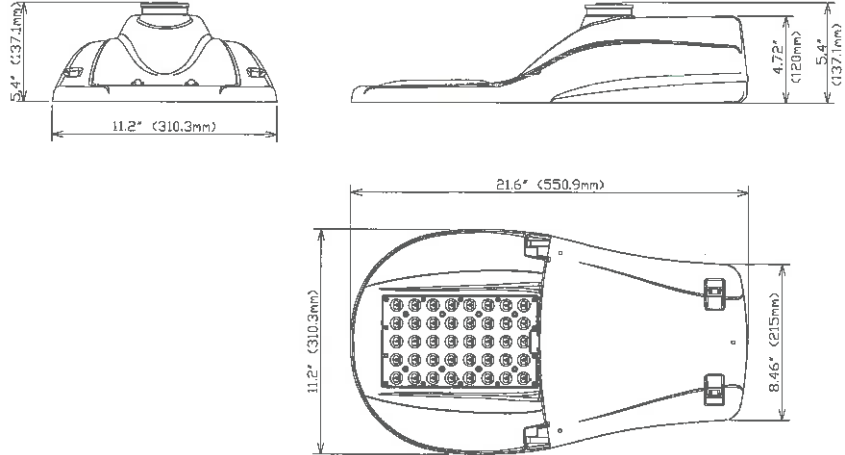

Ordering Information

Sample Catalog No. GCM1 30F MV NW 2 GY 700 PCR7 WL

Product	LED No. & Type	Voltage	Color Temperature	Distribution	Finish	Drive Current	Options
GCM1 30F@ 350 to 700mA	30F	MV 120-277V HV 347-480V	WW 3000K NW 4000K CW 5000K	2 Type 2 3 Type 3	GY Gray DB Dark Bronze BK Black	350 ² 350mA 530 ² 530mA 700 700mA 1A ³ 1A	FDC ⁴ Fixed Drive Current LPCR Less Photocontrol Receptacle PCR5 ⁵ ANSI 5-wire Photocontrol Receptacle PCR7 ⁵ ANSI 7-wire Photocontrol Receptacle PCR5-CR ⁶ Control Ready 5-wire PC Receptacle PCR7-CR ⁶ Control Ready 7-wire PC Receptacle WL Utility Wattage Label 4B 4-Bolt Mounting Bracket DSC Door Safety Cable RWG Rubber Wildlife Guard
GCM2 30F@ 700mA to 1A, 40F @ 700mA to 1A	40F						

Notes:

- 1 Factory set drive current, field adjustable standard. Refer to Performance Data Table. Consult factory if wattage limits require a special drive current.
- 2 350mA and 530mA drive current available with GCM1 only.
- 3 1A drive current available with GCM2 only.
- 4 Non-field adjustable, fixed drive current. Specify required drive current. Not available with PCR5-CR or PCR7-CR options.
- 5 Field adjustable current selector included. Wireless node dimming is disabled, field changeable connectors included to enable dimming with PCR5/7.
- 6 Control-ready wiring at factory for wireless node dimming. Default maximum drive current (700mA or 1A) must be specified.
- 7 Flush mounted house side shield. Shield cuts light off at 1/2 mounting height behind luminaire.
- 8 Flush mounted cul-de-sac shield. Shield cuts light off at 1/2 mounting height behind luminaire and 1-1/2 mounting height on either side of luminaire.
- 9 Specify Color (GY, DB, BK)
- 10 Specify MV (120-277V) or HV (347V-480V)

Accessories	
HSS ⁷	House Side Shield, Snap-On*
CSS ⁸	Cul-De-Sac Side Shield, Snap-On*
SPB ⁹	Square Pole Horizontal Arm Bracket
RPB ⁹	Round Pole Horizontal Arm Bracket
PTB ⁹	Pole Top Tenon Horizontal Arm Bracket
WB ⁹	Wall Horizontal Arm Bracket
BSK	Bird Deterrent Spider Kit
PC ¹⁰	Twist Lock Photocontrol
LLPC ¹⁰	Long-Life Twist Lock Photocontrol
SC	Twist Lock Shorting Cap

*Accessories are ordered separately and not to be included in the catalog number. For factory installed HSS, CSS specify as option in luminaire catalog number.



GreenCobra™ Midsize LED Street Light GCM

Luminaire Specifications

Housing

Die cast aluminum housing with universal two-bolt slip fitter mounts to 1-1/4" to 2" (1-5/8" to 2-3/8" O.D.) diameter mast arm. One-piece aluminum housing provides passive heat-sinking of the LEDs and has upper surfaces that shed precipitation. Four-bolt mounting bracket is available. Mounting provisions meet 3G vibration per ANSI C136.31-2001 Normal Application, Bridge & Overpass. Mounting has leveling adjustment from ± 5° in 2.5° steps. Electrical components are accessed without tools via a high-strength, non-conductive polycarbonate door with quick-release latches. Polycarbonate material meets UL 746C for outdoor usage. Available rubber wildlife guard (RWG option) conforms to mast arm with no gaps.

Light Emitting Diodes

Hi-flux/Hi-power white LEDs produce a minimum of 90% of initial intensity at 100,000 hours of life based on IES TM-21. LEDs are tested in accordance with IES LM-80 testing procedures. LEDs have correlated color temperature of 3000K (WW), 4000K (NW), or 5000K (CW) and 70 CRI minimum. LEDs are 100% mercury and lead free.

Performance Data

All data preliminary.

No. of LEDs & Type	Drive Current (mA)	System Wattage (W)	Delivered Lumens (Lm)	Efficacy (Lm/W) ¹	Type 2	Type 3
					BUG Rating	BUG Rating
GCM1 30F	350	36	3900	108	B1 U0 G1	B1 U0 G1
	530	57	6000	105	B1 U0 G1	B2 U0 G2
	700	69	7000	100	B2 U0 G2	B2 U0 G2
GCM2 30F	700	69	7000	100	B2 U0 G2	B2 U0 G2
	1000	104	9200	88	B2 U0 G2	B2 U0 G2
GCM2 40F	700	88	9000	102	B2 U0 G2	B2 U0 G2
	1000	138	12000	87	B2 U0 G2	B2 U0 G2

Notes:

1 Nominal lumens. Normal tolerance ± 10% due to factors including distribution type, LED bin variance, and ambient temperatures.

2 Not all versions DLC qualified. Consult qualified product list at www.designlights.org for latest product listing.

Optical Systems

Micro-lens optical systems produce IESNA Type 2 or Type 3 distributions and are fully sealed to maintain an IP66 rating. Luminaire produces 0% total lumens above 90° (BUG Rating, U=0). Optional house side shield cuts light off at 1/2 mounting height behind luminaire. Cul-de-sac shield provides back and side light control for end of cul-de-sac applications. Both shields are field installable without tools.

Electrical

Rated life of electrical components is 100,000 hours. Uses isolated power supply that is 1-10V dimmable. Power supply is wired with quick-disconnect terminals. LED drive current can be changed in the field to adjust light output for local conditions (not available with PCR5-CR or PCR7-CR options). Power supply features a minimum power factor of .90 and <20% Total Harmonic Distortion (THD). EMC meets or exceeds FCC CFR Part 15. Terminal block accommodates 2 to 14 gauge wire. Surge protection complies with IEEE/ANSI C62.41 Category C High, 20kV/10kA.

Controls

3-Wire photocontrol receptacle is standard. ANSI C136.41 5-wire (PCR5) or 7-wire (PCR7) photocontrol receptacles are available. All photocontrol receptacles have tool-less rotatable bases. Wireless control module is provided by others.

Finish

Housing receives a durable, fade-resistant polyester powder coat finish. Finish tested to withstand 3000 hours in salt spray exposure per ASTM B117. Finish tested 500 hours in UV exposure per ASTM G154 and meets ASTM D523 gloss retention.

Listings/Ratings/Labels

Luminaires are UL listed for use in wet locations in the United States and Canada. DesignLights Consortium™ qualified 120-277V product.² International Dark Sky Association listed. Luminaire is qualified to operate at ambient temperatures of -40°C to 40°C. Assembled in the U.S.A

Photometry

Luminaires photometrics are tested by certified independent testing laboratories in accordance with IES LM-79 testing procedures.

Warranty

10-year limited warranty is standard on luminaire and components.

GreenKingCobra™ LED Street Light GC2

Luminaire Data

Weight 25 lbs [11.3 kg]
EPA 1.0 ft²

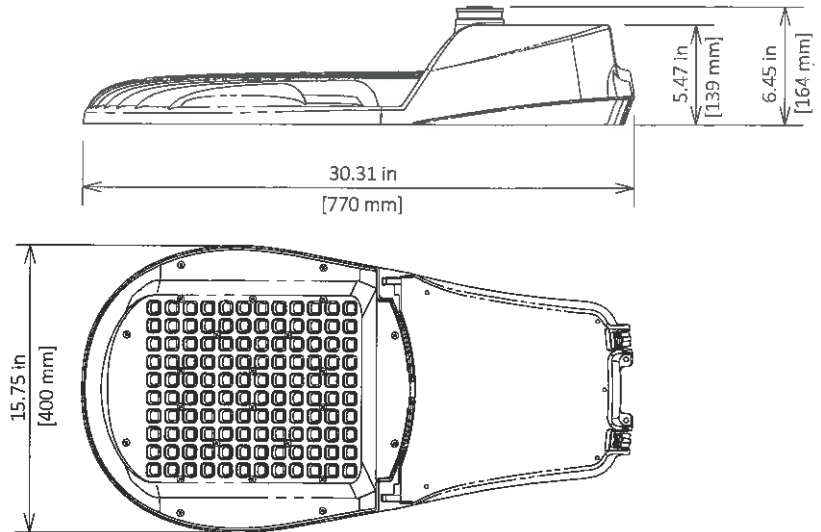

Ordering Information

Sample Catalog No. GC2 80F MV NW 2 GY BSK RPB FDC350

Product	No. & Type of LEDs	Voltage*	Color Temperature	Distribution	Finish*	Drive Current*	Options
GC2	80F	MV 120-277V	WW 3000K	2 Type 2	GY Gray	350 350mA	HSS ⁴ House Side Shield (Factory Installed)
	90F	HV 347-480V	NW 4000K	3 Type 3	DB Dark Bronze	530 530mA	FDC ⁵ Fixed Drive Current
	100F		CW 5000K		BK Black	700 700mA	LPCR Less Photocontrol Receptacle
	120F					1A ³ 1A	PCR5 ANSI 5-wire Photocontrol Receptacle PCR7 ANSI 7-wire Photocontrol Receptacle PCR5-CR Control Ready 5-wire Photocontrol Receptacle PCR7-CR Control Ready 7-wire Photocontrol Receptacle SC PCR Shorting Cap WL Utility Wattage Label

Notes:

- 1 Factory set drive current, field adjustable standard. Refer to Performance Data Table Consult factory if wattage limits require a special drive current.
- 2 Gray, Black and Dark Bronze standard, consult factory for other finishes.
- 3 1A drive current only available with 40F.
- 4 Flush mounted house side shield factory installed. Shield cuts light off at 1/2 mounting height behind luminaire.
- 5 Non-field adjustable, fixed drive current.
- 6 MV is DLC qualified. HV is DLC qualified on request, consult factory.
- 7 Flush mounted house side shield. Shield cuts light off at 1/2 mounting height behind luminaire. Specify Model and Color.
- 8 Specify Color (GY, DB, BK)
- 9 Specify MV (120-277V) or HV (347V-480V)

Accessories*

HSS ⁷	House Side Shield
SPB ⁸	Square Pole Horizontal Arm Bracket
RPB ⁸	Round Pole Horizontal Arm Bracket
PTB ⁸	Pole Top Tenon Horizontal Arm Bracket
WB ⁸	Wall Horizontal Arm Bracket
BSK	Bird Deterrent Spider Kit
PC ⁹	Twist Lock Photocontrol
LLPC ⁹	Long-Life Twist Lock Photocontrol
SC	Twist Lock Shorting Cap

*Accessories are ordered separately and not to be included in the catalog number

Luminaire Specifications

Housing

Die cast aluminum housing with universal four-bolt slip fitter mounts to 1-1/4" to 2" (1-5/8" to 2-3/8" O.D.) diameter mast arm. Aluminum housing provides passive heat-sinking of the LEDs and has upper surfaces that shed precipitation. Mounting provisions meet 3G vibration per ANSI C136.31-2001 Normal Application, Bridge & Overpass. Mounting has leveling adjustment from + 10° to -5° in 2.5° steps and integral bubble level standard. Electrical components are accessed without tools and are mounted on removable power door with stainless steel latches. Standard rubber wildlife guard conforms to mast arm with no gaps.

Light Emitting Diodes

Hi-flux/Hi-power white LEDs produce a minimum of 90% of initial intensity at 100,000 hours of life based on IES TM-21. LEDs are tested in accordance with IES LM-80 testing procedures. LEDs have correlated color temperature of 3000K (WW), 4000K (NW), or 5000K (CW) and 70 CRI minimum. LEDs are 100% mercury and lead free.

Optical Systems

Micro-lens optical systems produce IESNA Type 2 or Type 3 distributions and are fully sealed to maintain an IP66 rating. Luminaire produces 0% total lumens above 90° (BUG Rating, U=0). Optional house side shield cuts light off at 1/2 mounting height behind luminaire.

Electrical

Rated life of electrical components is 100,000 hours. Uses isolated power supply that is 1-10V dimmable. Power supply is wired with quick-disconnect terminals. LED drive current can be changed in the field to adjust light output for local conditions (not available with PCR5-CR or PCR7-CR options). Power supply features a minimum power factor of .90 and <20% Total Harmonic Distortion (THD). EMC meets or exceeds FCC CFR Part 15. Terminal block accommodates 2 to 14 gauge wire and is aligned for strait wire entry. Surge protection complies with IEEE/ANSI C62.41 Category C High, 20kV/10kA.

Controls

3-Wire photocontrol receptacle is standard. ANSI C136.41 5-wire (PCR5) or 7-wire (PCR7) photocontrol receptacles are available. All photocontrol receptacles have tool-less rotatable bases. Wireless control module is provided by others.

Finish

Housing receives a fade and abrasion resistant polyester powder coat finish. Finish tested to withstand 3000 hours in salt spray exposure per ASTM B117. Finish tested 500 hours in UV exposure per ASTM G154 and meets ASTM D523 gloss retention.

Listings/Ratings/Labels

Luminaires are UL listed for use in wet locations in the United States and Canada. DesignLights Consortium™ qualified 120-277V 4000K product. International Dark Sky Association listed. Luminaire is qualified to operate at ambient temperatures of -40°C to 40°C. Assembled in the U.S.A

Photometry

Luminaires photometrics are tested by certified independent testing laboratories in accordance with IES LM-79 testing procedures.

Warranty

10-year limited warranty is standard on luminaire and components.

Performance Data

All data nominal, consult factory for IES files or LM-79 reports.

No. of LEDs & Type	Drive Current (mA)	System Wattage (W)	Delivered Lumens (lm) ¹	Efficacy (lm/W)	Type 2	Type 3
					BUG Rating	BUG Rating
80F	700	180	17700	98	B3 U0 G3	B3 U0 G3
	1000	277	24500	88	B4 U0 G4	B4 U0 G4
90F	350	95	10800	114	B2 U0 G2	B3 U0 G3
	530	150	16050	107	B3 U0 G3	B3 U0 G3
100F	700	195	19800	102	B3 U0 G3	B3 U0 G3
	350	105	11700	111	B3 U0 G3	B3 U0 G3
	530	167	17400	104	B3 U0 G3	B3 U0 G3
120F	700	220	22000	100	B3 U0 G3	B3 U0 G3
	350	130	14600	112	B3 U0 G3	B3 U0 G3
	530	200	20800	104	B3 U0 G3	B3 U0 G3
	700	260	26400	102	B4 U0 G4	B4 U0 G4

Notes:

1 Nominal lumens. Normal tolerance ± 10% due to factors including distribution type, LED bin variance, and ambient temperatures.

Project Date

Catalog # Prepared by

Luminaire Type

Comments

LEDioc® - Hardwired LED Lamp Retrofit Engineered Solution

Applications include: Street/Area, Historic Districts, City Parks & Recreation, Campuses, Glass Lens Post Tops, Plastic Lens Post Tops, Teardrop Pendants

Specification Features

Construction

The LED retrofit kit includes a separate LED light source, LED driver and transient immunity device (TID). All three components are individually replaceable. The LED retrofit kit is capable of field adjusting the light center length of the LED light source to match the photometric light center length of the original luminaire.

Mounting

LED lampholder is hardwire mounted on a clamp assembly and can be field adjustable. Medium and Mogul base designs are available.

Optics

Designed for use in the existing HID post top and pendant mount luminaire optics. House-Friendly™ versions available with reduced house side lumens.

Electrical

Constant Current Driver is 120-277V input, with 0-10V dimming capability, and the operating temperature is -30° to +60° C. The 25W lamp (28 system watts) along with the 37W lamp (41.5 system watts) driver has a 300mA output and the 57W lamp (63 system watts) driver has a 350mA output. Electrical components are mounted separately to allow for easy serviceability. Transient immunity device (TID) or surge protector supplied per system requirements.

Reliability

The LEDioc lamp features cast aluminum passive thermal management, which allows air circulation around each LED module to ensure optimal lighting performance and long life.

Warranty

See the EYE Lighting full Warranty and Terms and Conditions of Sale at www.eyelighting.com.

Order Guide

CATALOG NUMBER	DESCRIPTION
LEH - 25WH323 - 830 - HWD - XXXX - UNV - 1*	25W House-Friendly, 3-Sides, 2-Sides Populated, 3000K, 85 CRI, Hardwired, 120-277V, standard TID
LEH - 25WH323 - 840 - HWD - XXXX - UNV - 1*	25W House-Friendly, 3-Sides, 2-Sides Populated, 4000K, 83 CRI, Hardwired, 120-277V, standard TID
LEH - 25WH323 - 750 - HWD - XXXX - UNV - 1*	25W House-Friendly, 3-Sides, 2-Sides Populated, 5000K, 70 CRI, Hardwired, 120-277V, standard TID
LES - 37W333 - 830 - HWD - XXXX - UNV - 1*	37W, 3-Sides, 3-Sides Populated, 3000K, 85 CRI, Hardwired, 120-277V, standard TID
LES - 37W333 - 840 - HWD - XXXX - UNV - 1*	37W, 3-Sides, 3-Sides Populated, 4000K, 83 CRI, Hardwired, 120-277V, standard TID
LES - 37W333 - 750 - HWD - XXXX - UNV - 1*	37W, 3-Sides, 3-Sides Populated, 5000K, 70 CRI, Hardwired, 120-277V, standard TID
LEH - 37WH433 - 830 - HWD - XXXX - UNV - 1*	37W, House-Friendly, 4-Sides, 3-Sides Populated, 3000K, 85 CRI, Hardwired, 120-277V, standard TID
LEH - 37WH433 - 840 - HWD - XXXX - UNV - 1*	37W, House-Friendly, 4-Sides, 3-Sides Populated, 4000K, 83 CRI, Hardwired, 120-277V, standard TID
LEH - 37WH433 - 750 - HWD - XXXX - UNV - 1*	37W, House-Friendly, 4-Sides, 3-Sides Populated, 5000K, 70 CRI, Hardwired, 120-277V, standard TID
LES - 57W443 - 830 - HWD - XXXX - UNV - 1*	57W, 4-Sides, 4-Sides Populated, 3000K, 84 CRI, Hardwired, 120-277V, standard TID
LES - 57W443 - 840 - HWD - XXXX - UNV - 1*	57W, 4-Sides, 4-Sides Populated, 4000K, 85 CRI, Hardwired, 120-277V, standard TID
LES - 57W443 - 750 - HWD - XXXX - UNV - 1*	57W, 4-Sides, 4-Sides Populated, 5000K, 70 CRI, Hardwired, 120-277V, standard TID

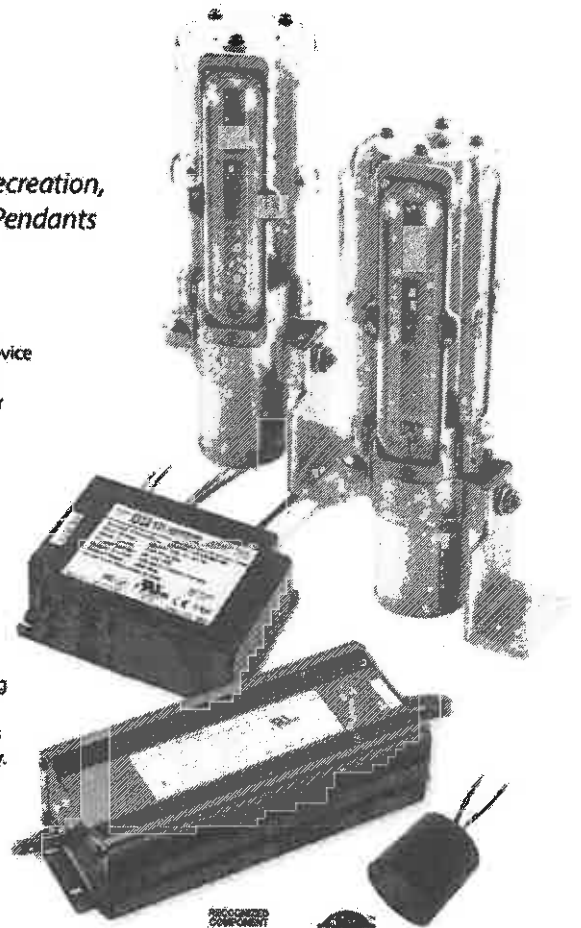

Check for latest updates at www.Designlights.org for listed product catalog numbers. Hardwired versions are listed. Contact company for solution availability.

* PLEASE NOTE

- Luminaire description "XXXX" to be completed by factory.
 - Surge protector "1" indicates a standard 3-wire unit rated 10KA with surge indicator light. Options are "2" (a 2-wire unit rated 10KA with indicator light) or "3" (a 3-wire unit rated 10KA with indicator light).

LEDioc® - Hardwired LED Lamp Retrofit Engineered Solution

The complete LEDioc component kit includes: the exclusive patent pending EYE LEDioc lamp, driver, TID and mounting bracket for the specific luminaire. Installation is easy, thermal/mechanical compatibility is assured and lamp LCL is maintained, preserving the optics and photometric performance of the existing luminaire. Each solution includes luminaire-specific installation instructions for the installer. Other solutions available, contact the factory or visit eyelighting.com for other solutions.

GE Town and Country
Model# T10C Series



King Luminaire
Model # K118 series

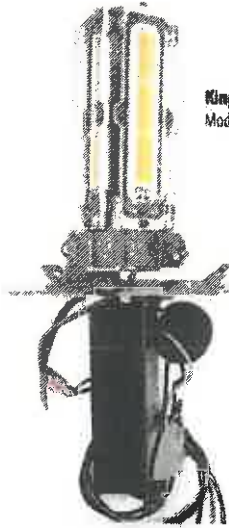

Hadco
Model # RS2 series



Hardwire Photometrics

37W STANDARD

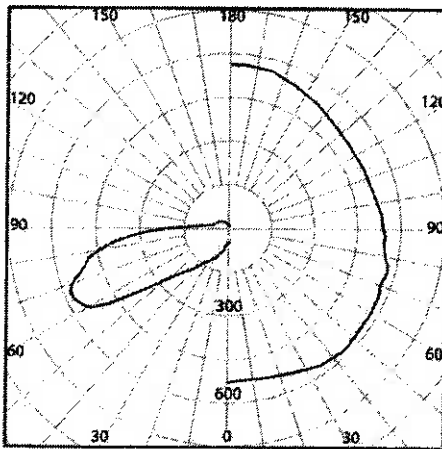

25W HOUSE-FRIENDLY™

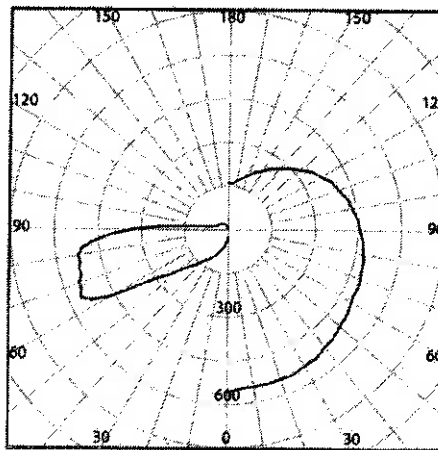

* Photometric distribution is based on Lexalite Lindy 424 per DLC specifications in a Type V distribution.

NOTES:

- 1) Applications are subject to project performance evaluation and may be subject to thermal validation prior to installation.
- 2) Actual design will vary based on specific luminaire mounting requirements.
- 3) Lexalite Lindy 424, GE Town and Country, King Luminaire, and Hadco are trademarks owned by their respective company.

EYE Lighting International of North America, Inc.
a division of Iwasaki Electric of Japan

9150 Hendricks Road
Mentor, Ohio 44060

Tel: (888) 665-2677
Fax: (440) 350-7001

www.eyelighting.com



SMOOTH FITTER

DECORATIVE FITTER
(for NEMA photocell option)

Applications Include

Urban streets, parks, residential areas, walkways, corporate and college campuses.

Specification Features

Construction

The main body is constructed from die cast aluminum featuring an easily removable stainless steel top that provides LED and driver accessibility for maintenance. The kiaroLED optics consist of an F1 rated, UV stabilized acrylic lens for maximum performance and durability. Easy and quick connects and disconnects from the modular LED board and driver, and stainless steel hardware are standard factory installed features. The kiaroLED Post Top offers a twist lock photocell mounted inside the optional decorative fitter providing full functionality without loss of architectural appeal.

Mounting

The standard smooth fitter provides a smooth transition from a 4.5" O.D. pole to the luminaire. A 4" to 5" long 3" or 3 1/2" O.D. tenon is required and is held in place with six 3/16"-16 set screws. The optional decorative fitter provides mounting to 2 3/8", 2 7/8", 3" and 4" O.D. pole and is held in place with three 3/16"-16 set screws. Connection to the terminal block is located conveniently in the base allowing direct access during installation. Terminal block connections accept 2 gauge to 14 gauge wire..

Optics

The luminaire provides IES Type II, III, IV, and V distribution patterns. Optical distribution patterns, lumen levels, and color temperatures are interchangeable and easily replaceable. Exclusive kiaroLED optical assembly contains captured stainless steel screws and quick disconnects for ease of field replacement and maintenance.

Electrical

The standard LED driver features 0-10VDC dimming and allows input from 120-277V, 50/60Hz, and an integral step down transformer is used for 347/480V installations. The driver operates at greater than 0.9 Power Factor and lower than 20% Total Harmonic Distortion. A replaceable built-in surge protector is rated to withstand 10kV/10kA of transient line surge. The kiaroLED Post Top is rated for 60,000 hours of operation and is suitable in -35°C to 40°C ambient conditions.

Finish

EYE Lighting utilizes a multi-stage cleaning, pretreatment and chemical conversion coating process. A durable polyester powdercoat is then electrostatically applied to a 2 to 3 mil thickness. This process ensures protection from impact, UV and salt spray damage.

Warranty

5 Year Limited LED Luminaire Warranty to the original purchaser that the luminaire shall be free from defects in material and workmanship for up to five (5) years from date of shipment. This limited warranty covers the fixture, LED driver and LEDs when installed and operated according to manufacturer's instructions. See EYE Lighting's full Warranty and Terms & Conditions of Sale at www.eyelighting.com.

Listings and Ratings

UL Listed in the U.S.A. and Canada to U.L. 1598 wet location standards. IP65 rated upper housing. Tested to IESNA LM-79-08 test standards at 25°C ambient. IES files are available at www.eyelighting.com.



SAMPLE NUMBER: PS-L440-57-UY-N-VE1

Order Guide

FAMILY	LUMENS	CCT	TYPE	CRI	VOLTAGE	LENS	FINISH	PHOTOCELL	WIRING
PS = Smooth Fitter	L4 ¹ = ~4,000	40 = 4000K	2 = II 3 = III 4 = IV 5 = V	7 70	U = 120-277V H ² = 347/480V	Y = Acrylic	G = Gray H = Charcoal K = Black N = Dark Bronze S = Silver W = White Q ⁴ = Custom	R ⁵ = Internal NEMA Photocell Receptacle V = No Photocell	E1 = Terminal block, #2 AWG to #14 AWG E2 = Terminal block with #14 AWG wire leads
PD = Decorative Fitter	L7 = ~7,000 L10 ² = ~10,000	50 = 5000K							

1 Reference photometric data sheet for lumen levels based on color temperature and distribution type
 2 35°C maximum ambient temperature
 3 347/480V steps down to 200/277V
 4 Consult factory when ordering custom finishes
 5 Requires optional decorative fitter, additional charge will apply

Dimensions
Standard smooth fitter

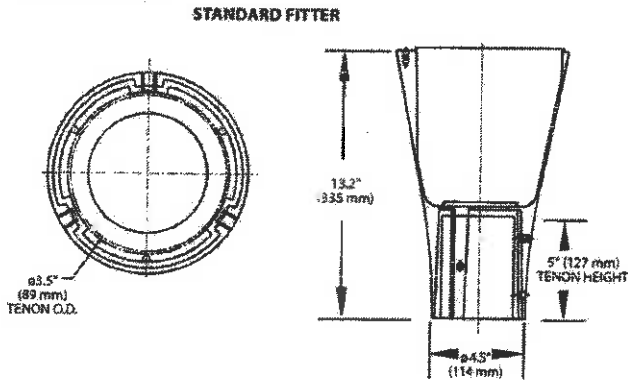

Weight 33 lbs.
EPA 2.14 ft³

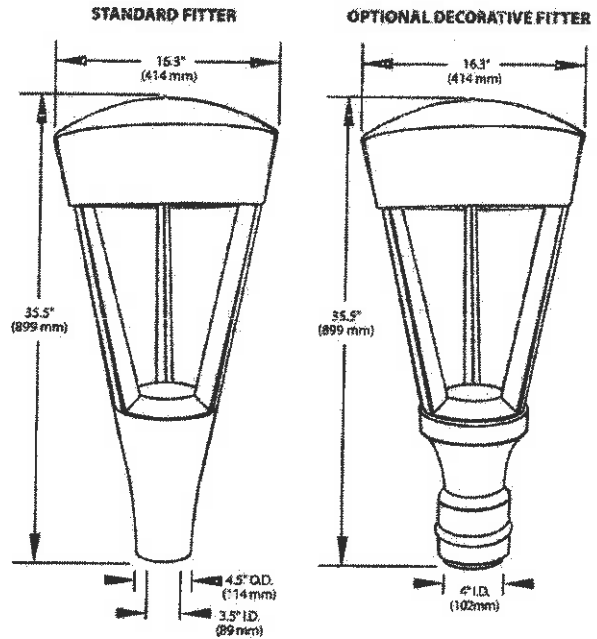

Performance Data

Wattage Summary

Model	LED Qty.	Drive Current	Luminaire Wattage	Average Lumens	Lumen Maintenance (L70 At 25°C)	Lumen Maintenance (L70 At 40°C)
L4	10	1050 mA	34	2,900	129,000 hrs.	129,000 hrs.
L7	10	2100 mA	68	5,200	129,000 hrs.	156,000 hrs.
L10	10	3150 mA	97	8,250	129,000 hrs.	163,000 hrs.

Ambient Data

Ambient Temperature	Lumen Multiplier
15°C	1.02
25°C	1.00
35°C	0.99
40°C	0.98

Photometric Data

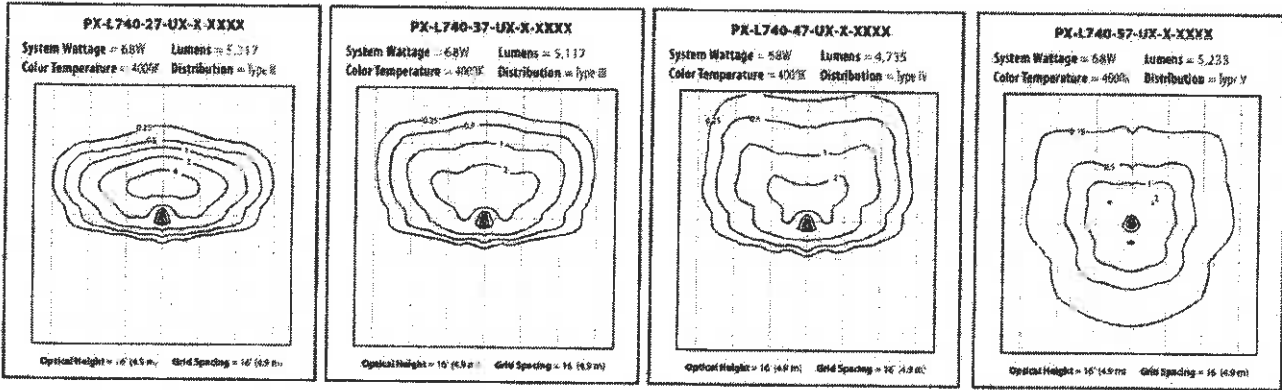

- Results may vary from test due to power, ambient conditions and individual component performance variations
- Data is provided to estimate typical performance
- Engineering estimates and data based on initial absolute lumen
- Lumen output may vary 10% due to LED manufacturer flux specification
- Predicted performance calculated from LED manufacturer data and engineering estimates based on test methodologies of IESNA LM-80, LM-79, and TM-21
- L70 Hours is the predicted time when LED performance degrades to 70% of initial lumen output
- EYE Lighting reserves the right to change materials or modify the design of its product without notification
- Consult factory for lead-time and availability
- Other modes of failure could occur after the 60,000 hour period
- Reference photometric data sheet for lumen levels based on color temperature and distribution type
- Patents Pending

EYE Lighting International of North America, Inc.
a division of Iwasaki Electric of Japan

9150 Hendricks Road
Mentor, Ohio 44060
Tel: (888) 665-2677
Fax: (440) 350-7001

www.eyelighting.com

EQSN-5276-00073 /1215



Monday, March 21, 2015

City of Darien
Daniel Gombac
Director of Municipal Services
1702 Plainfield Road
Darien, Illinois 60561

Dear Daniel Gombac & City of Darien

Lakeshore Lighting, LLC is extending this letter to you to confirm Lakeshore Lighting, LLC's direct buying relationship with Leotek Electronics USA LLC as requested for purposes regarding the 2016 Darien LED Streetlight Program.

Lakeshore Lighting, LLC is a direct distributor that submits purchase orders directly to Leotek Electronics USA LLC. The Pricing recently quoted to The City of Darien by Lakeshore Lighting is substantially lower than pricing obtained in the original bid, as Lakeshore Lighting secured lower utility pricing in order to make this project financially feasible.

If you would like further supplemental documentation, please let me know what you need from us in order to satisfy your requirements. Below, is a signature from Archibald & Meek, manufacturer's rep for Leotek Electronics LLC USA, acknowledging the validity of this document.

Sincerely,

Nicholas W. Betzold
Principal / Lakeshore Lighting, LLC

X Nicholas W. Betzold 3/21/16

Ray Doerrler
Sales Manager / Archibald & Meek (AMI)

X Ray Doerrler 3/21/16

Lakeshore Lighting, LLC
1204 E. Central Road
Arlington Heights, IL 60005

Phone: (847)-989-5843
Fax: (847)-387-3950
Email: nbetzold@lakeshorelight.com
Web: www.lakeshorelight.com



WARRANTY STATEMENT

General Illumination Products

AR, EC, GC, LWS, LSF, LCN, CL Series

Leotek AR, EC, GC, and LCN3-T Series Products are covered by a ten-year limited warranty, from the date of delivery. Leotek LWS, LSF, LCN1, LCN2, LCN3-K and CL Series Products are covered by a five-year limited warranty, from the date of delivery. Leotek warrants these products to be free of defects in workmanship and/or material. This warranty includes all electrical and mechanical components including finish and gaskets. Failure of over 10% of the LEDs in the luminaire during the warranty period will constitute a luminaire "failure" (except CL Series: 1 LED failure will constitute a unit failure).

Leotek Electronics USA Corp. will repair or replace any units found to be defective or that fail within this period. Leotek's liability under this warranty is limited to repair or replacement of the unit with a comparable product utilizing the current technology at the time of replacement.

Leotek will not be liable for defects due to improper handling, misuse, negligence, accidents, acts of God or nature, exposure to casualty of elements, or unauthorized alteration/repair. In all such cases, the warranty is immediately null and void. This warranty does not cover photocells or any control or monitoring devices.

This warranty is exclusive of all other warranties, expressed or implied, and Leotek hereby specifically disclaims all other warranty claims of any type; including without limitation, a warranty of merchantability of any unit or its fitness for any particular use or purpose. The customer's remedy under this warranty is exclusive. In no event shall Leotek be liable for interruption of business loss, profits or indirect or consequential damages, injury to person or damage to property from any cause whatsoever.

Please contact your local Sales Representative prior to directly contacting Leotek. Leotek Technical assistance is available from our Technical Support Department during the hours of 8:00 AM to 5:00 PM Pacific Standard Time (PST), Monday through Friday, excluding major U.S. holidays. Please provide the model number of the product.

Return Material Authorization

Prior to returning any product for repair or replacement, Leotek requires that a Return Material Authorization (RMA) be issued. The RMA can only be issued by Leotek. When requesting an RMA, the following information must be provided to Leotek; product Model and Serial Numbers, Date of Manufacture, and a detailed description of the reason for return. A Leotek representative will document the issue at hand and make the appropriate arrangement for the return of the unit/product.

When returning the product, the customer must adhere to the following procedure(s):

- Prior to returning, contact customer support at (408) 380-1788 to obtain an RMA number (Return Material Authorization).
- Clearly mark shipment container with RMA number.
- Include a return address and contact information with the shipment.
- RMA's are shipped via customer paid postage to:
 - Leotek Electronics USA Corp. - 1955 Lundy Ave., San Jose, CA 95131

Verification of purchase may be required. Leotek will not be held responsible for any damage to the product that occurs during shipment. Failure to exercise the above RMA policy and procedures will void all warranty responsibilities on behalf of Leotek Electronics USA Corp.

Dan Gombac

From: Patrick A. Durkin <ragselectric@aol.com>
Sent: Monday, February 15, 2016 4:16 PM
To: Dan Gombac
Subject: Re: 2016 LED Retrofit Program Proposed Negotiation

Dan,

We are comfortable with the \$40.00 removal and \$40.00 installation of LEDs. Sorry for the delay in this response.

Pat Durkin**Rag's Electric**

630-739-RAGS (7247) = Office
 773-619-7640 = Cell

-----Original Message-----

From: Dan Gombac <dgombac@darienil.gov>
To: Rags Electric <ragselectric@aol.com>
Cc: Bryon Vana <bvana@darienil.gov>; Kathy Weaver (Kathy_Weaver@AJG.com) <Kathy_Weaver@AJG.com>; nbetzold <nbetzold@lakeshorelight.com>
Sent: Wed, Feb 3, 2016 10:19 am
Subject: 2016 LED Retrofit Program Proposed Negotiation

Good morning Pat:

We are currently reviewing the LED Street Light Program portion of the recent Street Light contract. While you are the awarded vendor for the program, the City has been unable to secure a grant to offset the costs. We have recently had the opportunity to reduce fixture costs through the manufacture on two items. Upon review of the costs, the City is requesting a review of your installation and removal costs as proposed within the highlighted section. Pending your review and response, Staff would like to request the City Council for consideration to complete all 627 fixtures over the next year. The manufacture would be passing on the fixture costs to you for our project.

Sincerely,

Daniel Gombac

Director of Municipal Services

630-353-8106

To receive important information from the City of Darien sign up for our electronic newsletter:

DARIEN DIRECT CONNECT

Follow the link below and subscribing is simple!

<http://www.darien.il.us/Departments/Administration/CityNews.html>

RESOLUTION NO. _____

A RESOLUTION AUTHORIZING THE MAYOR AND CITY CLERK TO ACCEPT A PROPOSAL FROM LAKE SHORE LIGHTING, FOR THE PURCHASE OF LED STREET LIGHT HEADS AT A COST NOT TO EXCEED \$187,160.00 AS THEY RELATE TO THE CITY'S LED STREETLIGHT RETROFIT PROJECT

BE IT RESOLVED BY THE CITY COUNCIL OF THE CITY OF DARIEN, DU PAGE COUNTY, ILLINOIS, as follows:

SECTION 1: The City Council of the City of Darien hereby authorizes the Mayor and City Clerk to accept a proposal from Lake Shore Lighting for the purchase of LED Street Light Heads at a cost not to exceed \$187,160.00, as they relate to the City's LED Streetlight Retrofit Project, a copy of which is attached hereto as "**Exhibit A**", and is, by this reference, expressly incorporated herein.

SECTION 2: This Resolution shall be in full force and effect from and after its passage and approval as provided by law.

PASSED BY THE CITY COUNCIL OF THE CITY OF DARIEN, DU PAGE COUNTY, ILLINOIS, this 4th day of April, 2016.

AYES: _____

NAYS: _____

ABSENT: _____

APPROVED BY THE MAYOR OF THE CITY OF DARIEN, DU PAGE COUNTY, ILLINOIS, this 4th day of April, 2016.

KATHLEEN MOESLE WEAVER, MAYOR

ATTEST:

JOANNE E. RAGONA, CITY CLERK

APPROVED AS TO FORM

CITY ATTORNEY

LED RETROFIT PROGRAM

EXHIBIT A

PROPOSED PROGRAM WITH RENEGOTIATED PRICING									
2015 PRICING-BID TALLY MARCH 12, 2015									
	ITEM 1	ITEM 2	ITEM 3	ITEM 4	ITEM 5	ITEM 6	ITEM 7	ITEM 8	
Company Name	Eye Lighting LES-37W-333-840-HWD	Eye Lighting LES-57W-443-840-HWD	Eye Lighting PD-L4-40-5-7-U-Y-G-R-E1	Leotek Hss GCM 40	Leotek GCM2-40F-MV-NW-2-GY-1A	Leotek GC2-80F-MV-NW-3-GY-1A	Installation Costs	Cost to remove existing light head fixture	Total
Rag's Electric	\$ 444.00	\$ 504.00	\$ 794.00	\$ 18.00	\$ 312.00	\$ 571.00	\$ 49.50	\$ 49.50	\$ 2,742.00
Revised Pricing	\$ 393.00	\$ 438.00	\$ 724.00	\$ 18.00	\$ 256.00	\$ 449.00	\$ 40.00	\$ 40.00	\$ 2,358.00
Meade Electric	\$ 450.75	\$ 511.32	\$ 800.80	\$ 18.37	\$ 315.73	\$ 578.20	\$ 63.00	\$ 47.00	\$ 2,785.17
Lyons Electric	\$ 465.00	\$ 528.00	\$ 830.00	\$ -	\$ 335.00	\$ 597.00	\$ 140.00	\$ 20.00	\$ 2,915.00

QUANTITY BREAKDOWN-BID TALLY MARCH 12, 2015 UNIT PRICING									
QUANTITY	ITEM 1	ITEM 2	ITEM 3	ITEM 4	ITEM 5	ITEM 6	ITEM 7	ITEM 8	Total
	Eye Lighting LES-37W-333-840-HWD	Eye Lighting LES-57W-333-840-HWD	Eye Lighting P-L4-45-5-7-U-Y-N-R-E1	Leotek Hss GCM 40	Leotek GCM2-40F-MV-NW-2-GY-1A	Leotek GC2-80F-MV-NW-3-GY-1A	Installation Costs	Cost to remove existing light head fixture	Total
198					\$ 61,776.00				\$ 61,776.00
224					\$ 61,776.00				\$ 61,776.00
45						\$ 25,695.00			\$ 25,695.00
12						\$ 6,852.00			\$ 6,852.00
17	\$ 7,548.00								\$ 7,548.00
61		\$ 30,744.00							\$ 30,744.00
14			\$ 11,116.00						\$ 11,116.00
571							\$ 28,264.50	\$ 28,264.50	\$ 56,529.00
BID TALLY COST									\$ 262,036.00

REVISED PROGRAM SUMMARY-WITH RE-NEGOTIATED PRICING									
QUANTITY	ITEM 1	ITEM 2	ITEM 3	ITEM 4	ITEM 5	ITEM 6	ITEM 7	ITEM 8	Total
	Eye Lighting LES-37W-333-840-HWD	Eye Lighting LES-57W-333-840-HWD	Eye Lighting P-L4-45-5-7-U-Y-N-R-E1	Leotek Hss GCM 40	Leotek GCM2-40F-MV-NW-2-GY-1A	Leotek GC2-80F-MV-NW-3-GY-1A	Installation Costs	Cost to remove existing light head fixture	Total
198					\$ 50,688.00				\$ 50,688.00
224					\$ 57,344.00				\$ 57,344.00
45						\$ 20,205.00			\$ 20,205.00
12						\$ 5,388.00			\$ 5,388.00
17	\$ 6,681.00								\$ 6,681.00
61		\$ 26,718.00							\$ 26,718.00
14			\$ 10,136.00						\$ 10,136.00
571	\$ 6,681.00	\$ 26,718.00	\$ 10,136.00	\$ -	\$ 108,032.00	\$ 25,593.00			\$ 177,160.00
MATERIAL COSTS									\$ 177,160.00
CONTINGENCY-MATERIAL									\$ 10,000.00
TOTAL MATERIAL COSTS									\$ 187,160.00
CONTINGENCY-LABOR									\$ 22,840.00
TOTAL LABOR COSTS									\$ 10,000.00
TOTAL PROJECT COST									\$ 242,840.00

ROI	Energy Savings	Maintenance	Total
Annual Cost Savings	\$ 15,000.00	\$ 12,000.00	\$ 27,000.00
Project Cost Material and Labor	\$ 222,840.00		
Contingency	\$ 20,000.00		
Total Cost	\$ 242,840.00		
Illinois Clean Energy Grant	\$ 25,000.00		
Adjusted Project Cost	\$ 197,840.00		
No of years to recoup costs	7.33		

RESOLUTION NO. _____

A RESOLUTION AUTHORIZING THE MAYOR AND CITY CLERK TO ACCEPT THE REVISED UNIT PRICING FROM RAGS ELECTRIC IN AN AMOUNT NOT TO EXCEED \$55,680.00 FOR THE REMOVAL OF THE EXISTING STREET LIGHT HEADS AND THE INSTALLATION OF THE NEW LED FIXTURES AS THEY RELATE TO THE CITY'S LED STREETLIGHT RETROFIT PROJECT.

BE IT RESOLVED BY THE CITY COUNCIL OF THE CITY OF DARIEN, DU PAGE COUNTY, ILLINOIS, as follows:

SECTION 1: The City Council of the City of Darien hereby authorizes the Mayor and City Clerk to accept a proposal to accept the revised unit pricing from Rags Electric in an amount not to exceed \$55,680.00 for the removal of the existing street light heads and the installation of the new LED fixtures as they relate to the City's LED Streetlight Retrofit Project, a copy of which is attached hereto as "**Exhibit A**" and is, by this reference, expressly incorporated herein.

SECTION 2: This Resolution shall be in full force and effect from and after its passage and approval as provided by law.

PASSED BY THE CITY COUNCIL OF THE CITY OF DARIEN, DU PAGE COUNTY, ILLINOIS, this 4th day of April, 2016.

AYES: _____
NAYS: _____
ABSENT: _____

APPROVED BY THE MAYOR OF THE CITY OF DARIEN, DU PAGE COUNTY, ILLINOIS, this 4th day of April, 2016.

KATHLEEN MOESLE WEAVER, MAYOR

ATTEST:

JOANNE E. RAGONA, CITY CLERK

APPROVED AS TO FORM

CITY ATTORNEY

LED RETROFIT PROGRAM

EXHIBIT A

PROPOSED PROGRAM WITH RENEGOTIATED PRICING									
2015 PRICING-BID TALLY									
MARCH 12, 2015									
	ITEM 1	ITEM 2	ITEM 3	ITEM 4	ITEM 5	ITEM 6	ITEM 7	ITEM 8	
Company Name	Eye Lighting LES-37W-333-840-HWD	Eye Lighting LES-57W-443-840-HWD	Eye Lighting PD-L4-40-5-7-U-Y-G-R-E1	Leotek Hss GCM 40	Leotek GCM2-40F-MV-NW-2-GY-1A	Leotek GC2-80F-MV-NW-3-GY-1A	Installation Costs	Cost to remove existing light head fixture	Total
Rag's Electric	\$ 444.00	\$ 504.00	\$ 794.00	\$ 18.00	\$ 312.00	\$ 571.00	\$ 49.50	\$ 49.50	\$ 2,742.00
Revised Pricing	\$ 393.00	\$ 438.00	\$ 724.00	\$ 18.00	\$ 256.00	\$ 449.00	\$ 40.00	\$ 40.00	\$ 2,358.00
Meade Electric	\$ 450.75	\$ 511.32	\$ 800.80	\$ 18.37	\$ 315.73	\$ 578.20	\$ 63.00	\$ 47.00	\$ 2,785.17
Lyons Electric	\$ 465.00	\$ 528.00	\$ 830.00	\$ -	\$ 335.00	\$ 597.00	\$ 140.00	\$ 20.00	\$ 2,915.00

QUANTITY BREAKDOWN-BID TALLY MARCH 12, 2015 UNIT PRICING									
QUANTITY	ITEM 1	ITEM 2	ITEM 3	ITEM 4	ITEM 5	ITEM 6	ITEM 7	ITEM 8	Total
	Eye Lighting LES-37W-333-840-HWD	Eye Lighting LES-57W-333-840-HWD	Eye Lighting P-L4-45-5-7-U-Y-N-R-E1	Leotek Hss GCM 40	Leotek GCM2-40F-MV-NW-2-GY-1A	Leotek GC2-80F-MV-NW-3-GY-1A	Installation Costs	Cost to remove existing light head fixture	Total
198					\$ 61,776.00				\$ 61,776.00
224					\$ 61,776.00				\$ 61,776.00
45						\$ 25,695.00			\$ 25,695.00
12						\$ 6,852.00			\$ 6,852.00
17	\$ 7,548.00								\$ 7,548.00
61		\$ 30,744.00							\$ 30,744.00
14			\$ 11,116.00						\$ 11,116.00
571							\$ 28,264.50	\$ 28,264.50	\$ 56,529.00
BID TALLY COST									\$ 262,036.00

REVISED PROGRAM SUMMARY-WITH RE-NEGOTIATED PRICING									
QUANTITY	ITEM 1	ITEM 2	ITEM 3	ITEM 4	ITEM 5	ITEM 6	ITEM 7	ITEM 8	Total
	Eye Lighting LES-37W-333-840-HWD	Eye Lighting LES-57W-333-840-HWD	Eye Lighting P-L4-45-5-7-U-Y-N-R-E1	Leotek Hss GCM 40	Leotek GCM2-40F-MV-NW-2-GY-1A	Leotek GC2-80F-MV-NW-3-GY-1A	Installation Costs	Cost to remove existing light head fixture	Total
198					\$ 50,688.00				\$ 50,688.00
224					\$ 57,344.00				\$ 57,344.00
45						\$ 20,205.00			\$ 20,205.00
12						\$ 5,388.00			\$ 5,388.00
17	\$ 6,681.00								\$ 6,681.00
61		\$ 26,718.00							\$ 26,718.00
14			\$ 10,136.00						\$ 10,136.00
571	\$ 6,681.00	\$ 26,718.00	\$ 10,136.00	\$ -	\$ 108,032.00	\$ 25,593.00			\$ 177,160.00
MATERIAL COSTS									\$ 177,160.00
CONTINGENCY-MATERIAL									\$ 177,160.00
TOTAL MATERIAL COSTS									\$ 10,000.00
571							\$ 22,840.00	\$ 22,840.00	\$ 187,160.00
CONTINGENCY-LABOR									\$ 45,680.00
TOTAL LABOR COSTS									\$ 10,000.00
TOTAL PROJECT COST									\$ 55,680.00
									\$ 242,840.00

ROI	Energy Savings	Maintenance	Total
Annual Cost Savings	\$ 15,000.00	\$ 12,000.00	\$ 27,000.00
Project Cost Material and Labor	\$ 222,840.00		
Contingency	\$ 20,000.00		
Total Cost	\$ 242,840.00		
Illinois Clean Energy Grant	\$ 25,000.00		
Adjusted Project Cost	\$ 197,840.00		
No of years to recoup costs	7.33		

AGENDA MEMO
Municipal Services Committee Meeting
March 28, 2016

ISSUE STATEMENT

Approval of an ordinance authorizing the disposal of surplus property.

BACKGROUND/HISTORY

Staff is requesting that the following property be declared as surplus property and auctioned using an on-line auction service, Public Surplus, or disposed of:

ITEM	EXPLANATION
1 Unit 302 - 1984 B&O Welding Trailer (Serial #157382)	Obsolete Equipment
2 Unit 103 - 1999 GMC 9-ton Truck with plow & spreader (Vin #1GDP7HIC1YJ504740)	Replaced
3 Unit 114 - 2003 Ford E-350 Van (Vin #1FTSS34L93HA09469)	Replaced
4 Unit 120 - 2003 Ford Expedition XLT Truck (Vin #1FMPU16L33LC32407)	Replaced
5 Unit B-4 1997 Lexus ES300 (Vin #JT8BF22GXV5012713)	Replaced
6 Unit 202 - 2006 Kubota ZD21F Mower (Serial # 60733)	Replaced
7 Blueprint copier - Kip 1900 (Serial #10600226)	Replaced
8 CH Tractor - Craftsman 917.25892 (Serial #051497C002714)	Past useful service life (non-operational)
9 Craftsman - blower attachment	Past useful service life (non-operational)
10 Craftsman - blade attachment	Past useful service life (non-operational)
11 Craftsman - spreader attachment	Past useful service life (non-operational)
12 Craftsman - aerator attachment	Past useful service life (non-operational)

STAFF/COMMITTEE RECOMMENDATION

Staff recommends the above be declared surplus property and auctioned using Public Surplus or disposed of.

ALTERNATE CONSIDERATION

As recommended by the Committee.

DECISION MODE

If approved by the Committee, this item will be placed on the April 4, 2016 City Council Agenda for formal approval.

CITY OF DARIEN
DU PAGE COUNTY, ILLINOIS

ORDINANCE NO. _____

**AN ORDINANCE AUTHORIZING THE SALE
OF PERSONAL PROPERTY
OWNED BY THE CITY OF DARIEN**

**ADOPTED BY THE
MAYOR AND CITY COUNCIL
OF THE
CITY OF DARIEN
THIS ____ DAY OF _____**

**Published in pamphlet form by authority
of the Mayor and City Council of the City
of Darien, DuPage County, Illinois, this
____ day of _____, 2016.**

ORDINANCE NO. _____

**AN ORDINANCE AUTHORIZING THE SALE
OF PERSONAL PROPERTY
OWNED BY THE CITY OF DARIEN**

WHEREAS, in the opinion of at least three fourths of the corporate authorities of the City of Darien, it is no longer necessary or useful, or for the best interests of the City of Darien, to retain ownership of the personal property hereinafter described; and

WHEREAS, it has been determined by the Mayor and City Council of the City of Darien to sell said personal property at a Public Auction or dispose of said property.

NOW, THEREFORE, BE IT ORDAINED BY THE CITY COUNCIL OF THE CITY OF DARIEN, DU PAGE COUNTY, ILLINOIS, IN THE EXERCISE OF ITS HOME RULE POWERS, as follows:

SECTION 1: The Mayor and City Council of the City of Darien find that the following described personal property, now owned by the City of Darien, is no longer necessary or useful to the City of Darien and the best interests of the City of Darien will be served by auctioning it using Public Surplus or disposing of said property.

ITEM	EXPLANATION
1 Unit 302 - 1984 B&O Welding Trailer (Serial #157382)	Obsolete Equipment
2 Unit 103 - 1999 GMC 9-ton Truck with plow & spreader (Vin #1GDP7HIC1YJ504740)	Replaced
3 Unit 114 - 2003 Ford E-350 Van (Vin #1FTSS34L93HA09469)	Replaced
4 Unit 120 - 2003 Ford Expedition XLT Truck (Vin #1FMPU16L33LC32407)	Replaced
5 Unit B-4 1997 Lexus ES300 (Vin #JT8BF22GXV5012713)	Replaced
6 Unit 202 - 2006 Kubota ZD21F Mower (Serial # 60733)	Replaced

ORDINANCE NO. _____

7	Blueprint copier – Kip 1900 (Serial #10600226)	Replaced
8	CH Tractor – Craftsman 917.25892 (Serial #051497C002714)	Past useful service life (non-operational)
9	Craftsman – blower attachment	Past useful service life (non-operational)
10	Craftsman – blade attachment	Past useful service life (non-operational)
11	Craftsman – spreader attachment	Past useful service life (non-operational)
12	Craftsman – aerator attachment	Past useful service life (non-operational)

SECTION 2: The City Administrator is hereby authorized and directed to sell the aforementioned personal property, now owned by the City of Darien. Items will be auctioned using Public Surplus or disposing of said property.

SECTION 3: This Ordinance and each of its terms shall be the effective legislative act of a home rule municipality without regard to whether such Ordinance should (a) contain terms contrary to the provisions of current or subsequent non-preemptive state law, or (b) legislate in a manner or regarding a matter not delegated to municipalities by state law. It is the intent of the corporate authorities of the City of Darien that to the extent that the terms of this Ordinance should be inconsistent with any non-preemptive state law, that this Ordinance shall supersede state law in that regard within its jurisdiction.

SECTION 4: This Ordinance shall be in full force and effect from and after its passage and approval as provided by law.

PASSED BY THE CITY COUNCIL OF THE CITY OF DARIEN, DU PAGE COUNTY, ILLINOIS, this _____ day of _____

AYES: _____

ORDINANCE NO. _____

NAYS: _____

ABSENT: _____

APPROVED BY THE MAYOR OF THE CITY OF DARIEN, DU PAGE COUNTY,
ILLINOIS, this _____ day of _____

KATHLEEN MOESLE WEAVER, MAYOR

ATTEST:

JOANNE RAGONA, CITY CLERK

APPROVED AS TO FORM:

CITY ATTORNEY

**MINUTES
CITY OF DARIEN
MUNICIPAL SERVICES COMMITTEE
March 7, 2016**

PRESENT: Joseph Marchese – Chairperson, Alderman Thomas Belczak, Alderman Thomas Chlystek, Alderman Tina Beilke, Dan Gombac – Director, City Administrator Bryon Vanna, Elizabeth Lahey - Secretary

ABSENT: None

ESTABLISH QUORUM

Chairperson Marchese called the meeting to order at 6:45 p.m. at the City Hall – City Council Chambers, Darien, Illinois and declared a quorum present.

NEW BUSINESS

- a. Resolution – Approval of a resolution to amend the Private Property Development Storm Water Management Assistance Policy for an additional funding level, Level 1 and Level 2, for the Rear Yard Drainage Program Assistance Program.**

Mr. Dan Gombac, Director reported that the Municipal Services Committee discussed this item on January 25, 2016 and February 16, 2016. He reported that this item was discussed with the Administration Finance Committee-Committee of the Whole, on February 29, 2016 and that the Committee of the Whole agreed to fund an amount of \$72,300 for the FYE 17 Budget.

Mr. Gombac reported that this is the final version of the amended policy. He reported that one column was added to the spreadsheet referenced in the Agenda Packet adding another total cost column.

Mr. Gombac reported that the Mayor requested that staff not be authorized to authorize expenditures above \$5,000.

Alderman Belczak questioned why not give staff authorization. He stated that it seemed like a waste of time for the Council.

Chairperson Marchese agreed and stated that staff is doing the work and it just does not make sense.

City Administrator Bryon Vanna stated that the City Administrator currently has authority. He stated that the Ordinance will also need to be updated.

Mr. Gombac reported that he will amend the final Agenda memo for the City Council.

There was no one in the audience wishing to present public comment.

Alderman Chlystek made a motion and it was seconded by Alderman Belczak to recommend approval of A RESOLUTION AUTHORIZING THE MAYOR TO AMEND THE PRIVATE PROPERTY-DEVELOPMENT STORM WATER MANAGEMENT ASSISTANCE POLICY FOR AN ADDITIONAL FUNDING LEVEL, LEVEL 2 FOR THE REAR YARD DRAINAGE ASSISTANCE PROGRAM.

Upon voice vote, **THE MOTION CARRIED UNANIMOUSLY 3-0.**

- b. Resolution – Approval of a resolution accepting the unit price proposal for analytical soil testing fees from Testing Services Corporation at the proposed unit prices for certain waste for a period of May 1, 2016 through April 30, 2017.**

Mr. Dan Gombac, Director reported that during the year the Public Works department generates excavated materials from various projects, such as water main breaks, valve and hydrant replacements, landscape restorations and ditching projects. He reported that the law requires that any excavation needs to be soil tested. He further reported that there was one bid from Testing Service Corporation and that they have performed work for the City with satisfactory results.

There was no one wishing to present public comment.

Alderman Chlystek made a motion and it was seconded by Alderman Belczak to approve A RESOLUTION ACCEPTING THE UNIT PRICE PROPOSAL FOR ANALYTICAL SOIL TESTING FEES FROM TESTING SERVICES CORPORATION AT THE PROPOSED UNIT PRICES FOR CERTAIN WASTE FOR A PERIOD OF MAY 1, 2016 THROUGH APRIL 30, 2017.

Upon voice vote, **THE MOTION CARRIED UNANIMOUSLY 3-0.**

- c. Minutes – January 25, 2016 Municipal Services Committee – February 16, 2016 Municipal Services Committee – Special Meeting.**

Alderman Belczak made a motion and it was seconded by Alderman Chlystek to approve the January 25, 2016 Municipal Services Committee Meeting Minutes and the February 16, 2016 Municipal Services Committee Special Meeting Minutes.

Upon voice vote, **THE MOTION CARRIED UNANIMOUSLY 3-0.**

DIRECTOR'S REPORT

Mr. Gombac had no report.

NEXT SCHEDULED MEETING

Chairperson Marchese announced that the next regularly scheduled meeting is scheduled for Monday, March 28, 2016 at 6:30 p.m.

ADJOURNMENT

With no further business before the Committee, Alderman Chlystek made a motion and it was seconded by Alderman Belczak to adjourn. Upon voice vote, THE MOTION CARRIED unanimously and the meeting adjourned at 6:54 p.m.

RESPECTFULLY SUBMITTED:

Joseph Marchese
Chairman

Thomas Belczak
Alderman

Thomas Chlystek
Alderman