

CITY OF DARIEN TEMPORARY AMENDMENT TO CITY COUNCIL MEETING RULES FOR COMPLIANCE WITH ILLINOIS OPEN MEETINGS ACT:

- In person attendance at City Council meetings have resumed as of June 1, 2020. All elected officials may elect to participate in a City Council meeting by way of audio or video conferencing. The Council member's absence must be because of personal illness or disability; employment purposes; city business; or a family or other emergency. If a member of the council wishes to attend the meeting by means of a video or audio conference, the member must notify the city clerk of his or her nonattendance as soon as is reasonably possible so that the clerk may make appropriate arrangements.
- The public will be permitted to attend a City Council meeting but the meeting room will be limited to 50 members of the public at one time. The public will be required to maintain social distancing rules and are required to wear a mask while in the building.
- Members of the public physically present must be able to hear all discussion and testimony and all votes of the members of the body. This would mean that members of the public physically present, if more than 50, can be in a different room at City Hall. For example, this can be accomplished by offering a call-in telephone number, a web-based link such as YouTube presenting meeting live or viewing the meeting on cable at City Hall.

Visit the City of Darien [YouTube channel](#) to view the meeting live.

EXECUTIVE SESSION – 7:00 P.M. – PERSONNEL SECTION 2(C)(1) OF THE OPEN MEETINGS ACT

PRE-COUNCIL WORK SESSION — 7:00 P.M.

Revised Agenda of the Regular Meeting

of the City Council of the

CITY OF DARIEN

July 20, 2020

7:30 P.M.

1. Call to Order
2. Pledge of Allegiance
3. Roll Call
4. Declaration of Quorum
5. Questions, Comments and Announcements — **General (This is an opportunity for the public to [make comments or ask questions on any issue](#) – 3 Minute Limit Per Person, Additional Public Comment Period - Agenda Item 18)**
6. Approval of Minutes — [June 15, 2020](#)

7. Receiving of Communications
8. Mayor's Report
 - A. [Deneen M. Ruffolo – Darien Lions Club Humanitarian of the Year](#)
 - B. Consideration of a Motion to Approve the [Appointment of Claudia Borowski and Ryan Grace to the Environmental Committee](#)
 - C. Consideration of a Motion to Approve the [Reappointment of Deb Hardtke, Allan Jackimek, and Arleta Peknik to the Environmental Committee](#)
 - D. Consideration of a Motion to Approve the [Reappointment of John J. Armellino to the Board of Fire and Police Commissioners](#)
 - E. Consideration of a Motion to Approve the [Reappointment of Jeff May to the Police Pension Board](#)
 - F. Metro Strategies – [Quarterly Report](#)
9. City Clerk's Report
10. City Administrator's Report
11. Department Head Information/Questions
 - A. Police Department
 - B. Municipal Services
12. Treasurer's Report
 - A. Warrant Number — [20-21-05](#)
 - B. Warrant Number — [20-21-06](#)
13. Standing Committee Reports
14. Questions and Comments — **Agenda Related (This is an opportunity for the public to [make comments or ask questions on any item on the Council's Agenda](#) – 3 Minute Limit Per Person)**
15. Old Business
16. Consent Agenda
 - A. Consideration of a Motion to Approve [an Ordinance Replacing Title 8 \(Police Regulations\) Chapter 20 \(Drug Paraphernalia\)](#) of the City of Darien City Code
 - B. Consideration of a Motion to Approve [an Ordinance Replacing Title 8, Police Regulations, Chapter 7 Cannabis](#) Regulations of the City of Darien City Code
17. New Business
 - A. Consideration of a Motion to Approve the [Darien Chamber of Commerce 20thAnnual Darien Dash](#), A 10k Run/a 5K Run/1 Mile Walk, on August

23, 2020 Beginning at 8:00 A.M. and Authorize the Chief of Police to Finalize the Details of This Event with the Chamber of Commerce

- B. Consideration of a Motion to Approve the Use of the Right Half of the Following Streets for the [Darien Dash](#):

The 5K and 10K Course:

Start on Ironwood Avenue at the Darien Swim and Recreation Club and Head North to 69th street. Turn East on to 69th Street to Richmond Avenue; Turn South on Richmond Avenue to 70th Street; Turn East on 70th Street to Bentley Avenue; Turn North on Bentley Avenue to 69th Street; Turn East on 69th Street to Clarendon Hills Road; Turn South on Clarendon Hills Road to 70th Street; Turn West on 70th Street to Bentley Avenue; Turn South on Bentley Avenue to Maple Lane; Turn East on Maple Lane to Clarendon Hills Road; Turn South on Clarendon Hills Road to 71st Street; Turn West 71st Street to Bentley Avenue; Turn North on Bentley Avenue to Maple Lane; Turn West onto Maple Lane to Richmond Avenue; Turn South on Richmond Avenue to 71st Street; Turn West on 71st Street to Beechnut Lane; Turn North on Beechnut Lane to Ironwood Avenue; Turn East on Ironwood Avenue to Start/Finish Line

1-Mile Course:

Start on Ironwood Avenue at the Darien Swim and Recreation Club and Head North to 69th Street. Turn East on to 69th Street to Sierra Drive; Turn South on Sierra Drive to 71st Street; Turn West on 71st Street to Beechnut Lane; Turn North on Beechnut Lane to Ironwood Avenue; Turn West on Ironwood Avenue to Start/Finish Line

- C. Consideration of a Motion to Approve an Ordinance Granting a Variation from Section 5A-5-9-8(B) (PZC 2020-06 [8131 Lemont Road](#))
- D. Consideration of a Motion to Approve a Resolution Approving an Intergovernmental Agreement Between the City of Darien and DuPage County for [Participation in DuPage County Local Government Covid-19 Reimbursement Program](#)
- E. Consideration of a Motion to Direct Staff to [Proceed with a Landscape Enhancement Project and Easement Agreement for the Northwest Corner at 7532 Cass Avenue, PIN# 09-28-402-025](#)
18. Questions, Comments and Announcements — **General (This is an opportunity for the public to [make comments or ask questions on any issue](#) – 3 Minute Limit Per Person)**
19. Adjournment

A WORK SESSION WAS CALLED TO ORDER AT 7:06 P.M. BY MAYOR MARCHESE FOR THE PURPOSE OF REVIEWING ITEMS ON THE JUNE 15, 2020 AGENDA WITH THE CITY COUNCIL. THE WORK SESSION ADJOURNED AT 7:20 P.M.

Minutes of the Regular Meeting

of the City Council of the

CITY OF DARIEN

June 15, 2020

7:30 P.M.

1. **CALL TO ORDER**

The regular meeting of the City Council of the City of Darien was called to order at 7:30 P.M. by Mayor Marchese.

2. **PLEDGE OF ALLEGIANCE**

Mayor Marchese led the Council and audience in the Pledge of Allegiance.

3. **ROLL CALL** — The Roll Call of Aldermen by Clerk Ragona was as follows:

Present:	Thomas J. Belczak	Ted V. Schauer
	Thomas M. Chlystek	Mary Coyle Sullivan
	Eric K. Gustafson	Lester Vaughan
	Joseph A. Kenny	

Absent: None

Also in Attendance: Joseph Marchese, Mayor
JoAnne E. Ragona, City Clerk
Michael J. Coren, City Treasurer
Bryon D. Vana, City Administrator
Gregory Thomas, Police Chief
Daniel Gombac, Director of Municipal Services

4. **DECLARATION OF A QUORUM** — There being seven aldermen present, Mayor Marchese declared a quorum.

5. **QUESTIONS, COMMENTS AND ANNOUNCEMENTS – GENERAL**

There were none.

6. **APPROVAL OF MINUTES** – June 1, 2020

It was moved by Alderman Kenny and seconded by Alderman Schauer to approve the minutes of the City Council Meeting of June 1, 2020.

Roll Call:	Ayes:	Belczak, Chlystek, Gustafson, Kenny, Schauer
	Abstain:	Sullivan, Vaughan
	Nays:	None
	Absent:	None

Results: Ayes 7, Nays 0, Absent 0

MOTION DULY CARRIED

7. **RECEIVING OF COMMUNICATIONS**

Alderman Schauer received communication in opposition of proposed sign at the northwest corner of Plainfield Road & Cass Avenue from Joan & Jack Graham, Michelle Houska, Joan & Rich Brandeis and Bryan Gay.

Alderwoman Sullivan...

...received communication from Larry Smith, Gleneyre Road, regarding utility easement in need of repair on Carriage Green Drive; Director Gombac addressed the issue.

...apprised resident of sewer project after notification from Director Gombac.

...noted Anna & Richard Garro, Gleneagles Lane, were in attendance regarding their pool.

...received communication from Brookeridge Creek residents regarding Honey Bee Farm located on Kearney Road in unincorporated Downers Grove.

...received communication from Bryan Gay, Joan & Rich Brandeis, the Krupickas and the Johnsons in opposition of proposed sign at Plainfield Road & Cass Avenue.

Alderman Kenny received communication from...

...Carole Jurkash regarding policing; communication was forwarded to Chief Thomas.

...Bonnie Kucera, Sue Profitt, Michelle Houska, Linda Painter, Kathleen Abbate, and Joan & Jack Graham opposing proposed sign at Plainfield Road & Cass Avenue.

Alderman Chlystek...

...received several emails regarding policing; Chief Thomas responded.

...commented about Police Department monthly report.

...received communication mostly in opposition of proposed sign at Plainfield Road & Cass Avenue.

Mayor Marchese received communication from...

...Jim & Chuck Pine, owners of Chuck's Southern Comforts, thanking City for reimbursement of Food & Beverage Taxes.

...Matt Stafford, Joan Gundlash, Michelle Houska, Sue Profitt, and Joan & Jack Graham opposing proposed sign at Plainfield Road & Cass Avenue.

...Susan & Dean Mikula, Andrew & Brooke Piasecke, Sarah & TK Booth, Betty Czaja, Jennifer Santucci, Vince & Rhonda Esposito and Greg Sullivan were in support of proposed sign.

8. **MAYORS REPORT**

Mayor Marchese read Mayoral Proclamation honoring Deputy Chief Rentka for his contributions, service, energy, and devotion to the City of Darien and Darien Police Department into the record; the Mayor presented proclamation to retiring Deputy Chief Rentka. He congratulated Deputy Chief Rentka and thanked him for his many years of dedicated service.

Chief Thomas presented Mrs. Rentka with a bouquet of flowers. Chief Thomas recognized Deputy Chief Rentka and complemented him on his professionalism and dedication to serving others.

Deputy Chief Rentka thanked Mayor Marchese and Administrator Vana for their support and opportunities provided; elected officials for their dedication; Director Gombac for a Public Works Department that is second-to-none; Darien Police Department officers & civilians; Chief Thomas for his wealth of knowledge, leadership, and strong set of values; and particularly his wife & sons for their love and support. He thanked everyone for their support and friendship; he expressed his gratefulness for the time spent in Darien and wished everyone the best.

Chief Thomas announced Sergeant Jason Norton would assume the responsibility of Deputy Chief on June 23, 2020. He reviewed the selection process and Sergeant Norton's background. Sergeant Norton thanked Chief Thomas for the opportunity to serve and Deputy Chief Rentka for all his guidance. He noted Darien is his second home, and he intends to make citizens proud. Mayor Marchese congratulated Sergeant Norton.

A. CONSIDERATION OF A MOTION TO APPROVE THE REAPPOINTMENT OF DEPARTMENT HEADS: GREGORY THOMAS, POLICE CHIEF AND DANIEL GOMBAC, DIRECTOR OF MUNICIPAL SERVICES

It was moved by Alderman Schauer and seconded by Alderman Kenny to approve the motion as presented.

Roll Call: Ayes: Belczak, Chlystek, Gustafson, Kenny, Schauer, Sullivan, Vaughan

Nays: None

Absent: None

Results: Ayes 7, Nays 0, Absent 0

MOTION DULY CARRIED

Clerk Ragona issued the Oath of Office to Chief Thomas and Director Gombac. Mayor Marchese thanked Chief Thomas and Director Gombac for their service. Director Gombac and Chief Thomas expressed their appreciation.

Mayor Marchese provided an update on restaurants and bars; he stated that hopefully on June 26 restaurants and bars can open to a limited indoor capacity. He commented the Economic Development Committee has been communicating with restaurant owners.

Mayor Marchese stated Food & Beverage refund checks were delivered to businesses. He encouraged residents to take advantage of outdoor/indoor dining.

9. **CITY CLERK'S REPORT**

Clerk Ragona noted:

- City offices will be closed on Friday, July 3, 2020 in observance of Independence Day.
- the July 6th City Council Meeting has been cancelled.
- the next City Council Meeting will be held on July 20, 2020.

10. **CITY ADMINISTRATOR'S REPORT**

Administrator Vana thanked Lisa Klemm & staff for updating the City website; he hopes residents find the site easier to utilize.

11. **DEPARTMENT HEAD INFORMATION/QUESTIONS**

A. POLICE DEPARTMENT MONTHLY REPORT – APRIL 2020

The April 2020 Police Department Monthly Report is available on the City website.

Chief Thomas provided an update on fireworks advising that they are illegal and dangerous. He addressed Council questions regarding fireworks, monthly report, diversity, state laws, union contracts, personnel policies, body cams and wrongful convictions.

B. MUNICIPAL SERVICES

Director Gombac stated...

...NiCor moved depressurizing equipment for a construction project near Lyman Avenue & Plainfield Road. Upon receipt of additional information, an update will be posted on social media.

...DuPage County requested information on Covid-19 expenses.

...firepit regulations will be reviewed at the upcoming Municipal Services Meeting; he requested resident feedback. Mayor Marchese provided background information. Alderman Kenny commented on regulation challenges.

12. **TREASURER’S REPORT**

A. WARRANT NUMBER 20-21-04

It was moved by Alderwoman Sullivan and seconded by Alderman Belczak to approve payment of Warrant Number 20-21-04 in the amount of \$547,969.10 from the enumerated funds, and \$266,654.21 from payroll funds for the period ending 06/04/20 for a total to be approved of \$814,623.31.

Roll Call: Ayes: Belczak, Chlystek, Gustafson, Kenny, Schauer, Sullivan, Vaughan

Nays: None

Absent: None

Results: Ayes 7, Nays 0, Absent 0

MOTION DULY CARRIED

13. **STANDING COMMITTEE REPORTS**

Municipal Services Committee – Chairman Belczak stated the minutes of the February 24, 2020 meeting were approved and submitted to the Clerk’s Office. He announced the next meeting of the Municipal Services Committee is scheduled for July 27, 2020 at 7:00 P.M.

Police Committee – Chairman Kenny stated the minutes of the February 18, 2020 meeting were approved and submitted to the Clerk’s Office. He announced the next meeting of the Police Committee is scheduled for July 20, 2020 at 6:00 P.M. in the Police Department Training Room.

14. **QUESTIONS AND COMMENTS – AGENDA RELATED**

There were none.

15. **OLD BUSINESS**

There was no Old Business.

16. **CONSENT AGENDA**

There was no Consent Agenda

17. **NEW BUSINESS**

Mayor Marchese changed the order of items as listed on the Agenda.

A. CONSIDERATION OF A MOTION TO APPROVE A RESOLUTION APPROVING A PLAT OF UTILITY EASEMENT VACATION AND A PLAT OF UTILITY EASEMENT FOR 8801 GLENEAGLES LANE 10-05-205-024

It was moved by Alderman Belczak and seconded by Alderwoman Sullivan to approve the motion as presented.

RESOLUTION NO. R-36-20

A RESOLUTION APPROVING A PLAT OF UTILITY EASEMENT VACATION AND A PLAT OF UTILITY EASEMENT FOR 8801 GLENEAGLES LANE 10-05-205-024

Roll Call: Ayes: Belczak, Chlystek, Gustafson, Kenny, Schauer, Sullivan, Vaughan

Nays: None

Absent: None

Results: Ayes 7, Nays 0, Absent 0

MOTION DULY CARRIED

B. CONSIDERATION OF A MOTION TO APPROVE AN ORDINANCE APPROVING A VARIATION TO THE DARIEN ZONING REGULATIONS (PZC 2020-04 7729 WARWICK AVENUE)

It was moved by Alderman Schauer and seconded by Alderman Belczak to approve the motion as presented.

ORDINANCE NO. O-11-20

AN ORDINANCE APPROVING A VARIATION TO THE DARIEN ZONING REGULATIONS (PZC 2020-04 7729 WARWICK AVENUE)

Roll Call: Ayes: Belczak, Chlystek, Gustafson, Kenny, Schauer, Sullivan, Vaughan

Nays: None

Absent: None

Results: Ayes 7, Nays 0, Absent 0

MOTION DULY CARRIED

C. CONSIDERATION OF A MOTION TO APPROVE AN ORDINANCE AMENDING SECTION 3-3-7-11(C) OF THE DARIEN CITY CODE

It was moved by Alderman Belczak and seconded by Alderman Schauer to approve the motion as presented.

ORDINANCE NO. O-10-20

AN ORDINANCE AMENDING SECTION 3-3-7-11(C) OF THE DARIEN CITY CODE

Roll Call: Ayes: Belczak, Chlystek, Gustafson, Kenny, Schauer, Sullivan, Vaughan

Nays: None

Absent: None

Results: Ayes 7, Nays 0, Absent 0

MOTION DULY CARRIED

D. CONSIDERATION OF A MOTION TO APPROVE THE EXPENDITURE OF BUDGETED FUNDS LINE ITEM 01-40-4325 CONSULTING/PROFESSIONAL SERVICES FOR THE ONE YEAR LAW ENFORCEMENT POLICY MANUAL UPDATE SUBSCRIPTION FROM LEXIPOL, LLC IN THE AMOUNT OF \$8,562.00

It was moved by Alderman Kenny and seconded by Alderman Schauer to approve the motion as presented.

Roll Call: Ayes: Belczak, Chlystek, Gustafson, Kenny, Schauer, Sullivan, Vaughan

Nays: None

Absent: None

Results: Ayes 7, Nays 0, Absent 0

MOTION DULY CARRIED

E. CONSIDERATION OF A MOTION TO APPROVE AN ORDINANCE GRANTING A SERIES OF VARIATIONS TO ALLOW THE CONSTRUCTION OF AN ELECTRONIC MESSAGE BOARD SIGN (NORTHWEST CORNER OF PLAINFIELD AND CASS)

It was moved by Alderman Belczak and seconded by Alderman Gustafson to approve the motion as presented.

Council members voiced their opinions regarding construction of electronic message board; Council discussion ensued.

Mayor Marchese stated he and Administrator Vana are investigating the opportunity to host a movie night in the parking lot of Carriage Greens Country Club.

Alderwoman Sullivan...

...commented houses of worship have started to reopen. As preregistration may be required and hours of services may have changed, she suggested calling or checking house of worship website for updates.

...thanked service organizations for food pantry donations.

Alderman Belczak noted...

...there will be no 4th of July parade.

...Darien Swim & Racket Club is reopening on July 3; additional information is available at www.darienswim.com. Mayor Marchese commented CDC guidelines will need to be followed.

19. **ADJOURNMENT**

There being no further business to come before the City Council, it was moved by Alderwoman Sullivan and seconded by Alderman Schauer to adjourn the City Council meeting.

VIA VOICE VOTE – MOTION DULY CARRIED

The City Council meeting adjourned at 9:06 P.M.

Mayor

City Clerk

All supporting documentation and report originals of these minutes are on file in the Office of the City Clerk under File Number 6-15-20. Minutes of 6-15-20 CCM.

Mayoral Proclamation

Whereas, Deneen Marie Ruffolo was born in Alsip, Illinois, the daughter of Robert and Jaqueline Spears. She has two siblings: Roberta Norkus and Paul Spears; and

Whereas, Deneen grew up in Darien, Illinois, attended local public schools, which included Concord Elementary School, Cass Junior High School, Hinsdale South High School and College of DuPage; and

Whereas, Deneen has been married to Greg Ruffolo for 36 years. They have two children: Cassondra, “Cassi”, married to Frank Noverini who have three daughters, Mia, Paige and Brooke; and Michael, married to Mallori who have one son, Carter; and

Whereas, Deneen has held a variety of job positions: 1980-1981 Pharmacy Tech at Walgreens in Darien; 1981 Ponderosa on Route 83; 1981-1983 teller at West Suburban Bank and in the Loan Department; 1983-1985 Loan Office Manager/Loan Servicing at Land of Lincoln Savings and Loan; 1991-2010 started her own decorating company, DR. Window Décor; and 2010 – Present Broker at Realty Executives; and

Whereas, Deneen has received many accolades for her achievements which included numerous sales trips as owner of DR. Window Décor, and “Top Producer” of her office countless times over her ten year span at Realty Executives Midwest. In 2016, she won the Great Lakes Region “Most Valuable Executive.” In 2017, Deneen was awarded 1st place in the Great Lakes Region for the number of listings taken and in the same year 1st place for total dollar volume of listings. In 2019, she achieved the status of being one of the top 5% of agents with Realty Executives International.

Whereas, Greg commented that Deneen is respected by her clients – she is always there for them and makes their transition as easy as possible. She has received many letters of appreciation from not only her managing broker but other brokers commenting on her willingness to help and her professionalism in completing transactions smoothly; and

Whereas, Deneen has volunteered her time in countless ways over the years. At Our Lady of Mt. Carmel she was the first teen on the Parish Council, a Religious Ed teacher and a Eucharistic Minister. Deneen’s Civic affiliations include:

- *Safety Village where she helped Cindy Hagen and Nick Perrin, owner of Home Run Inn, organize the first “Kids in the Park.” She sold so much pizza that year that Nick offered her a job at Home Run Inn!*
- *Darien Woman’s Club for six years as a member, Secretary, and Vice-President.*
- *Hinsdale South Post Prom Committee for six years to ensure a safe senior prom.*

Mayoral Proclamation

- *“Make-a-Wish” for ten years through Realty Executives.*
- *Tuesday morning Village Greens Ladies Golf League for three years where she served as Treasurer; and*

***Whereas,** Deneen has participated in Lions Club Food Baskets since 1993 delivering food to families in need. She has included her children and now grandchildren to instill the importance of what she likes to call “cycle of service.” In 2017, Deneen took over the gift portion of the Baskets which includes: obtaining toy donations & wrapping paper, sorting and overseeing the wrapping of more than 4,000 toys, and recruiting volunteers from Darien Lions Club, Darien Woman’s Club, Darien Rotary Club, Burr Ridge Senior Home and Hinsdale South High School; and*

***Whereas,** Deneen loves all sports. She especially loves to golf, swim and go to the beach and simply be in the sun; and*

***Whereas,** Greg has commented that Deneen taught her children how to properly treat others, to always be kind, not speak poorly of others but rather find good in them, to help by assisting others and in the end you will be rewarded. Deneen teaches her grandchildren how to be nice to others and to help those in need; Granddaughter Mia’s favorite song is “Be Humble and Kind” by Tim McGraw; and*

***Whereas,** the City of Darien is proud to honor Deneen Ruffolo as the 2020 Darien Lions Humanitarian of the Year.*

***NOW, THEREFORE,** I, Joseph A. Marchese, Mayor of the City of Darien, do hereby proclaim July 24, 2020 as*

DENEEN RUFFOLO DAY

in the City of Darien and recognize her many contributions to the community.

In Witness Whereof, I Have Hereunto Set My Hand And Caused To Be Affixed The Seal Of The City Of Darien, this twentieth day of July Two-Thousand Twenty.

Joseph A. Marchese, Mayor

Attest:

JoAnne E. Ragona, City Clerk

CITY OF DARIEN

MEMO

TO: City Council

FROM: Mayor Joseph Marchese

DATE: July 16, 2020

SUBJECT: APPOINTMENTS TO ENVIRONMENTAL COMMITTEE

This is written to request your advice and consent to the appointment of [Claudia Borowski](#) and [Ryan Grace](#) to the Environmental Committee. They have agreed to serve the City and have expressed an interest in this Committee.

As always, if you have any questions, please contact me.

mg



CITY OF DARIEN

APPLICATION FOR SERVICE ON CITY COMMISSION

Are you interested in serving on a City Commission? If so, please complete this application and return it to the Darien City Hall, 1702 Plainfield Road, Darien, Illinois 60561.

Date June 12, 2020

Name Claudia Borowski

Address [REDACTED] (Phone [REDACTED])

Email [REDACTED]

How long have you lived in Darien? about 48 years

Where did you live prior to coming to Darien? [REDACTED]

If Married, Spouse's Name - Children (include ages) [REDACTED]

Education: B.S. & graduate program If you attended college, what was your major? Biology

Present Employer Retired Phone _____

Address _____ Fax _____

Nature of Occupation _____

Other Employment Experience _____

Interests and Hobbies? Photography, gardening, birding, encouraging pollinators & environmental conservation

Of what local organizations have you been a member? (Please include offices held, if any) Darien Garden Club

(President 2017-18, Vice Pres 2016, Field Trip Chair 2015, Publicity Chair 2017-20) Parent/teacher org. at Concord & Cass

Have you served the community in any other way? Cert. Teachers Aide/Concord School(early years), Responsible for saving the Darien Milkweed Patch- assisted in planting the raingarden with Gift of Carl & "Mighty Acorns" at Lace School, planning plantings for the courtyard at Eisenhower Jr. High, work with several IPPL projects, assist Cindy & MaryBeth with Sunny Patch/Good Worx, join with Darien Historical Society & Woman's Club Plant Sale, joined as DGC in the Farmers Market & Flea Market, promote Darien in all publicity for DGC including our annual symposium "Spring Gardening Inspiration" at Chuck's Cafe, providing all citizens an opportunity to hear prominent speakers on environmental consciousness topics.

Time you would have available to serve the City being retired, I have time outside of my DGC responsibilities (I would not be available for meetings on the 1st & 3rd Mondays of the month.)

In which of the following areas would you like to serve? (Please feel free to check more than one.)

- Citizen of the Year Committee
- Economic Development Committee
- Environmental Committee
- Fire & Police Commission
- Planning and Zoning Commission
- Police Pension Board
- Other (Please specify) _____

What are your qualifications for this position(s)?

I can contribute my knowledge and sources of information from living in Darien, volunteering in Darien and being a member of many environmental & conservation organizations:

my yard is certified by National Wildlife Federation

member National Wildlife Federation

member Morton Arboretum

member The Conservation Foundation

Participant in Chicago Living Corridors

member of Audubon Society

member Nature Conservancy

member The Field Museum, Chicago

Participant in Million Pollinator Garden Challenge

member National Geographic

Student in Garden Clubs of Illinois Environmental School

(for certification as a "Environmental Consultant")

Why are you interested in this position(s)?

I have an avid interest in ecology, the environment, endangered species, water conservation, rain gardens, all that is being affected by global warming as well as contaminants & local issues we live with concerning our environment.

What can you contribute to this board(s) or commissions(s)?

I believe I have valid ideas to contribute to the activities of the Environmental Committee. Also because of my experience with the Darien Garden Club, I have gone to local, county and state environmental conferences. As a club we have had many years of speakers at our "Spring Gardening Inspiration" who have presented environmental concerns and facts to those attending from our community. These speakers are all sources of information, if needed. I, as well, have used as sources of knowledge: The Conservation Foundation, National Wildlife, Xerces Society, DuPage Monarch Project and local providers and designers of native plantings & raingardens. And more, whatever is appropriate.

NOTE: Enclosed is the article from 2019's DuPage Neighbors about the milkweed plants that were being cut down & poisoned in the county "right of way" that Darien is responsible for maintaining on Plainfield Road, just west of the exit road from the Police Department. As a result of my efforts and the assistance of Lisa Klemm, permission was granted by Dan Gombac to put up a sign (supplied by the Darien Garden Club) to describe the importance of the patch to the Monarch Butterfly and hopefully prevent "mowing & spraying". I have been in charge of the Darien Milkweed Patch since 2018, each year, in the fall when they are ripe, ALL THE SEED PODS are collected, seeds removed and distributed at our symposium, at IPPL and in our community. The remainder are donated to IDOT for distribution on our highways in Illinois. I have kept Lisa Klemm up to date on the patch during the summer and Municipal Services has only had to service the area once a year. (in the fall after the pods are collected).



CITY OF DARIEN

APPLICATION FOR SERVICE ON CITY COMMISSION

Are you interested in serving on a City Commission? If so, please complete this application and return it to the Darien City Hall, 1702 Plainfield Road, Darien, Illinois 60561.

Date June 5, 2020

Name Ryan Grace

Address [REDACTED] (Phone) [REDACTED]

Email [REDACTED]

How long have you lived in Darien? Less than one year

Where did you live prior to coming to Darien? [REDACTED]

If Married, Spouse's Name [REDACTED] Children (include ages) [REDACTED]

Education: [REDACTED] If you attended college, what was your major? [REDACTED]

Present Employer [REDACTED] Phone [REDACTED]

Address [REDACTED] Fax [REDACTED]

Nature of Occupation [REDACTED]

Other Employment Experience property management background, former elected village trustee,
[REDACTED]

Interests and Hobbies? when I am not working my family and I spend our time at our cabin
and just the craziness of daily life with two kids

Of what local organizations have you been a member? (Please include offices held, if any) [REDACTED]
zoning and planning board commissioner, village trustee, both Village of Lyons

Have you served the community in any other way? [REDACTED]
Darien, no not as of yet. We recently moved here so my son can attend Hinsdale South

Time you would have available to serve the City evenings and weekends as needed

In which of the following areas would you like to serve? (Please feel free to check more than one.)

- Citizen of the Year Committee
- Economic Development Committee
- Environmental Committee
- Fire & Police Commission
- Planning and Zoning Commission
- Police Pension Board
- Other (Please specify) as needed, happy to get involved

What are your qualifications for this position(s)?

I have always been involved in the Village of Lyons, from community events like the fourth of July and the annual car show. Also I volunteer for the senior events and holiday dinners. My professional background provides knowledge in many areas of village management and municipal codes. I would like to get involved in Darien now that I am a resident. I have been the Director of Public Works since 2017 and have a very good understanding of municipal operations.

Why are you interested in this position(s)?

I like to be involved in my local community. I have always had the opinion that you should give back to your community when you can. My background qualifies me to be involved in many areas and I am open to assist wherever you feel there is a need.

What can you contribute to this board(s) or commissions(s)?

I can contribute my past experience and knowledge. I am always willing to evaluate a problem and come up with reasonable and effective solutions. I feel that I typically bring a common sense approach to any problem presented to me. I would be more than happy to meet with you and better understand the needs of the community and where I may be a good fit.



CITY OF DARIEN

MEMO

TO: City Council

FROM: Mayor Joseph Marchese

DATE: July 16, 2020

SUBJECT: REAPPOINTMENTS TO ENVIRONMENTAL COMMITTEE

This is written to request your advice and consent to the reappointments of Deb Hartdke, Allan Jackimek, and Arleta Peknik to the Environmental Committee. They have expressed an interest in continuing to serve the City in this capacity.

Again, should you have any questions, please do not hesitate to contact me.

mg



CITY OF DARIEN

MEMO

TO: City Council

FROM: Mayor Joseph Marchese

DATE: July 16, 2020

SUBJECT: REAPPOINTMENT TO BOARD OF FIRE AND POLICE COMMISSIONERS

This is written to request your advice and consent to the reappointment of John J. Armellino to the Board of Fire and Police Commissioners. He has expressed an interest in continuing to serve the City in this capacity.

Again, should you have any questions, please do not hesitate to contact me.

mg



CITY OF DARIEN

MEMO

TO: City Council

FROM: Mayor Joseph Marchese

DATE: July 16, 2020

SUBJECT: REAPPOINTMENT TO POLICE PENSION BOARD

This is written to request your advice and consent to the reappointment of Jeff May to the Police Pension Board. He has expressed an interest in continuing to serve the City in this capacity.

Again, should you have any questions, please do not hesitate to contact me.

mg

City of Darien Communications Quarterly Report – Q2 2020

Q1 Audience Growth



Facebook: 417 new followers (↑ 15%, 3,206 total) and 375 new page likes (↑ 14%, 3,006 total)



Nextdoor: 351 new individual members (↑ 8+%, 4,729 total individual members)



Twitter: 172 new followers (↑ 23%, 931 total followers)



E-News: 140 new subscribers (↑ 3%, 5,190 total subscribers)

Engagement Highlights



Facebook:

- **118% increase** in monthly average engagements (clicks, “likes,” shares and comments)
 - 2,699/mo (Q1) → 5,884/mo (Q2)
 - Spike on May 31 around protests/looting post (2k+ engagements for that post alone)
- **122% increase** in monthly average post reach (number of people who see the City’s content)
 - 23k/mo (Q1) → 51.5k/mo (Q2)
- **127% increase** in monthly average impressions (number of times content appears in a user’s feed)
 - 39.8k/mo (Q1) → 90.5k/mo (Q2)

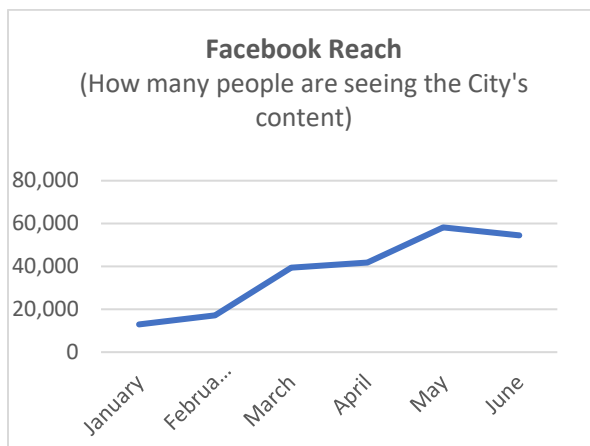
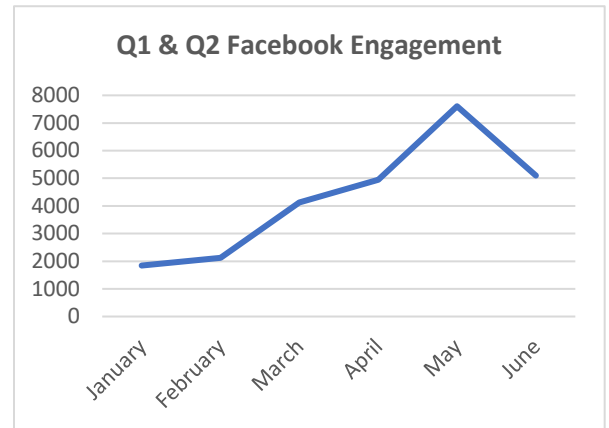



Nextdoor: City created Nextdoor Agency account in February 2020 and began posting mid-month

- **71% increase** in Nextdoor post impressions (how many people viewed the City's posts)
 - 20.2k/mo (Q1) → 34.5k/mo (Q2)
- **18% increase** in reactions (thanks, likes, etc.)
 - 95/mo (Q1) → 113/mo (Q2)

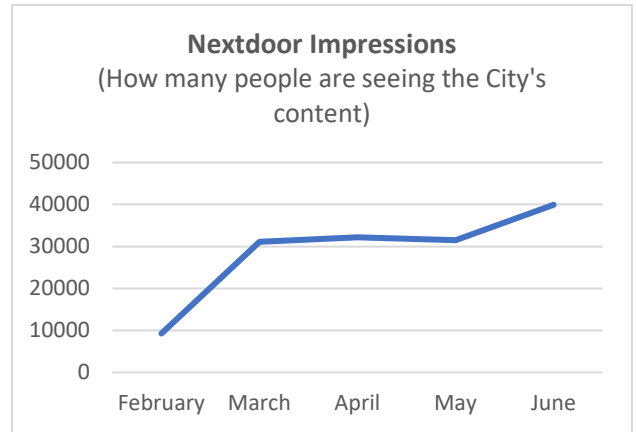

Twitter:

- **76% increase** in average monthly engagement (clicks, likes, retweets, comments)
 - Overall engagement: 464/mo (Q1) → 818/mo (Q2)
 - 129% increase in average monthly Tweet likes
 - 52% increase in average monthly Re-Tweets
- **84% increase** in monthly average impressions (how many people see City's content)
 - 12.6k/mo (Q1) → 23.2k/mo (Q2)

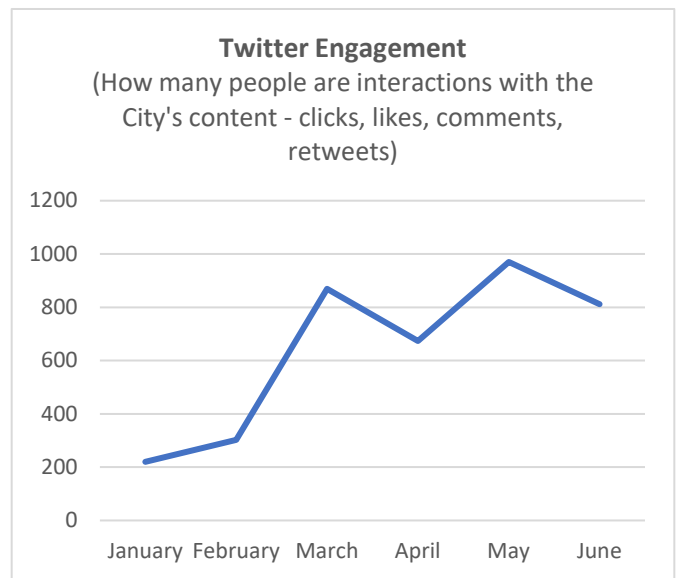

Key Takeaways:

Higher reach and engagement in these times of crisis (Q2: COVID-19, civil unrest and protests) indicates that residents are seeking locally-relevant information from trusted local sources. By continuing to provide accurate and transparent information during these times, the City can play a vital role in sharing information and build public trust. These increased engagement periods also allow the City to leverage opportunities to grow its audiences for general and crisis communications.

CITY OF DARIEN

**EXPENDITURE APPROVAL LIST
FOR CITY COUNCIL MEETING ON
July 20, 2020**

Approval is hereby given to have the City Treasurer of Darien, Illinois pay to the officers, employees, independent contractors, vendors, and other providers of goods and services in the indicated amounts as set forth.

A summary indicating the source of funds used to pay the above is as follows:

General Fund				\$46,126.65
Water Fund				\$15,638.07
Motor Fuel Tax Fund				\$5,321.74
Water Depreciation Fund				\$13,425.00
Special Service Area Tax Fund				
E-Citation Fund				
Capital Improvement Fund				51,485.01
State Drug Forfeiture Fund				\$198.77
Federal Equitable Sharing Fund				
DUI Technology Fund				
			Subtotal:	<u>\$132,195.24</u>
General Fund Payroll	06/18/20	\$		239,457.26
Water Fund Payroll	06/18/20	\$		23,115.33
General Fund Payroll	07/02/20	\$		242,869.66
Water Fund Payroll	07/02/20	\$		18,564.77
			Subtotal:	<u>\$ 524,007.02</u>
Total to be Approved by City Council:				<u>\$ 656,202.26</u>

Approvals:

Joseph A. Marchese, Mayor

JoAnne E. Ragona, City Clerk

Michael J. Coren, Treasurer

Bryon D. Vana, City Administrator

CITY OF DARIEN
Expenditure Journal
General Fund
Administration
From 6/16/2020 Through 7/6/2020

Vendor Name	Invoice Description	Session ID	Acct Code	Acct Title	Dept Amount
AIS	MONTHLY BACK UP SERVICE- JULY 2020	AP070620	4325	Consulting/Professional	1,300.00
AIS	CISCO SMART RENEWAL- ENDS 8-27-2021	AP070620	4325	Consulting/Professional	148.00
AIS	CLOUD HOSTING- JULY 2020	AP070620	4325	Consulting/Professional	20.00
AIS	MONTHLY BLOCK - JULY 2020	AP070620	4325	Consulting/Professional	5,130.26
CALL ONE, INC.	CITY TELEPHONE BILL	AP070620	4267	Telephone	1,564.74
CHRONICLE MEDIA LLC	LEGAL NOTICE: 2020 ZONING MAP	AP070620	4221	Legal Notices	35.00
COMCAST BUSINESS	COMCAST CABLE FOR CITY HALL	AP070620	4271	Utilities (Elec,Gas,Wtr,Sewer)	32.89
GOV QA	CRM SUBSCRIPTION - (7-21-20 thru 6-30-21)	AP070620	4325	Consulting/Professional	5,345.00
GOVTEMPSUSA LLC	VANA - (6-7-20)	AP070620	4325	Consulting/Professional	3,415.38
GOVTEMPSUSA LLC	VANA - (6-14-20)	AP070620	4325	Consulting/Professional	3,415.38
IMPACT NETWORKING, LLC	KONICA COPIER LEASE - (6-18-20 thru 7-17-20)	AP070620	4225	Maintenance - Equipment	150.00
METRO STRATEGIES	COMMUNICATION SERVICES- MAY 2020	AP070620	4239	Public Relations	4,000.00
MUNICIPAL WEB SERVICES	WEBSITE MAINTENANCE - MAY 2020	AP070620	4325	Consulting/Professional	415.00
NICOR GAS	NICOR 82541110001 1702 PLAINFIELD RD	AP070620	4271	Utilities (Elec,Gas,Wtr,Sewer)	121.62
OFFICE DEPOT	OFFICE SUPPLIES -CITY HALL	AP070620	4253	Supplies - Office	91.95
SUNCOM TV	CONNECT LAPTOP TO TRICASTER FOR ZOOM	AP070620	4815	Equipment	217.50
UNLIMITED GRAPHIX, INC.	PRINTING- AP CHECKS	AP070620	4235	Printing and Forms	519.20
VERIZON WIRELESS	VERIZON WIRELESS BILL	AP070620	4267	Telephone	1,265.19

CITY OF DARIEN
Expenditure Journal
General Fund
Administration
From 6/16/2020 Through 7/6/2020

<u>Vendor Name</u>	<u>Invoice Description</u>	<u>Session ID</u>	<u>Acct Code</u>	<u>Acct Title</u>	<u>Dept Amount</u>
				Total Administration	27,187.11

CITY OF DARIEN
Expenditure Journal
General Fund
Community Development
From 6/16/2020 Through 7/6/2020

<u>Vendor Name</u>	<u>Invoice Description</u>	<u>Session ID</u>	<u>Acct Code</u>	<u>Acct Title</u>	<u>Dept Amount</u>
CHRISTOPHER B. BURKE ENG, LTD	PLAN REVIEW - 981 N FRONTAGE	AP070620	4328	Const/Prof Reimbursable	738.03
CHRISTOPHER B. BURKE ENG, LTD	LETTER PREP FOR CLOSE OF PERMIT	AP070620	4328	Const/Prof Reimbursable	592.50
ELEVATOR INSPECTION SERVICE CO	ELEVATOR RE-INSPECTIONS	AP070620	4328	Const/Prof Reimbursable	50.00
GOV QA	GOV QA COMUNITY DEVELOPMENT	AP070620	4325	Consulting/Professional	1,665.00
				Total Community Development	3,045.53

CITY OF DARIEN
Expenditure Journal
General Fund
Public Works, Streets
From 6/16/2020 Through 7/6/2020

Vendor Name	Invoice Description	Session ID	Acct Code	Acct Title	Dept Amount
ADVANCE AUTO PARTS	OIL FILTER FOR 201	AP070620	4225	Maintenance - Equipment	15.75
ADVANCE AUTO PARTS	RETURN OIL FILTER FOR 201	AP070620	4225	Maintenance - Equipment	(15.75)
ADVANCE AUTO PARTS	LUBE FOR 106	AP070620	4229	Maintenance - Vehicles	48.52
ADVANCE AUTO PARTS	HYDRAULIC LUBE	AP070620	4229	Maintenance - Vehicles	18.36
ADVANCE AUTO PARTS	CREDIT- HYDRAULIC LUBE	AP070620	4229	Maintenance - Vehicles	(12.24)
ADVANCE AUTO PARTS	CREDIT- HYDRAULIC LUBE	AP070620	4229	Maintenance - Vehicles	(6.12)
ADVANCE AUTO PARTS	WIRE LOOM	AP070620	4229	Maintenance - Vehicles	31.00
ADVANCE AUTO PARTS	OIL FILTER	AP070620	4229	Maintenance - Vehicles	14.52
AQUA FIORI	SPRINKLER START-UP FOR CITY HALL AND POLICE DEPT	AP070620	4223	Maintenance - Building	300.00
BANNERVILLE USA INC	4TH OF JULY CUSTOM BANNER	AP070620	4257	Supplies - Other	485.00
CASE LOTS, INC.	JANITORIAL SUPPLIES	AP070620	4223	Maintenance - Building	224.65
CHEMSEARCH	VEHICLE MAINTENANCE SUPPLIES	AP070620	4229	Maintenance - Vehicles	320.14
CINTAS FIRST AID AND SAFETY	REPLENISH FIRST AID CABINET	AP070620	4219	Liability Insurance	96.19
COM ED	COM ED 0788310001 -1041 S FRONTAGE RD	AP070620	4271	Utilities (Elec,Gas,Wtr,Sewer)	56.09
DAVID BROWN	DAVE BROWN-CLOTHING	AP070620	4269	Uniforms	82.60
EJ USA, INC.	STORM SEWER	AP070620	4257	Supplies - Other	423.52
FIRST ADVANTAGE OCCUPATIONAL	RANDOM DRUG SCREEN	AP070620	4219	Liability Insurance	35.20
GOLDSTAR PRODUCTS INC.	GERMICIDAL WIPES	APVOID062220	4223	Maintenance - Building	(493.83)
GRAINGER	GARBAGE GRABBERS	AP070620	4259	Small Tools & Equipment	363.36
HINSDALE NURSERIES INC.	GRAVEL TO SURROUND REAR YARD SEWERS	AP070620	4374	Drainage Projects	114.00
HOME DEPOT	MAINTENANCE SUPPLIES	AP070620	4223	Maintenance - Building	1,195.96

CITY OF DARIEN
Expenditure Journal
General Fund
Public Works, Streets
From 6/16/2020 Through 7/6/2020

Vendor Name	Invoice Description	Session ID	Acct Code	Acct Title	Dept Amount
HOME DEPOT	OTHER SUPPLIES	AP070620	4257	Supplies - Other	711.63
INTERSTATE BILLING SERVICE INC	SUPPLIES FOR SHOP	AP070620	4229	Maintenance - Vehicles	202.90
INTERSTATE BILLING SERVICE INC	REPAIR PARTS	AP070620	4229	Maintenance - Vehicles	230.00
KAMAN FLUID POWER LLC	REPAIR PARTS FOR #111	AP070620	4229	Maintenance - Vehicles	269.92
KAMAN FLUID POWER LLC	REPAIR PARTS FOR #111	AP070620	4229	Maintenance - Vehicles	57.82
LINDCO EQUIPMENT SALES, INC.	REPAIR PARTS	AP070620	4229	Maintenance - Vehicles	59.10
MARTIN IMPLEMENT SALES, INC.	STOCK PARTS	AP070620	4225	Maintenance - Equipment	66.01
McMASTER-CARR	RESTROOM REPAIR/MAINTENANCE	AP070620	4223	Maintenance - Building	891.05
McMASTER-CARR	RESTROOM REPAIR/MAINTENANCE	AP070620	4223	Maintenance - Building	396.17
PIONEER RESEARCH	GROUT FOR SEWERS	AP070620	4257	Supplies - Other	956.10
SHREVE SERVICES INC	DITCH PROJECT: 67TH ST TOPSOIL	AP070620	4257	Supplies - Other	320.00
SHREVE SERVICES INC	TOPSOIL FOR OTHER PROJECTS	AP070620	4257	Supplies - Other	640.00
TAMELING INDUSTRIES	STRAW MAT AND STAPLES FOR LANDSCAPING	AP070620	4257	Supplies - Other	135.00
TITAN IMAGE GROUP INC	MASEK- CLOTHING	AP070620	4269	Uniforms	386.67
TRAFFIC CONTROL AND PROTECTION	SIGNS	AP070620	4257	Supplies - Other	275.80
TRI-K INC	SANITIZER	AP070620	4219	Liability Insurance	144.50
TRI-K INC	SHOP SUPPLIES	AP070620	4225	Maintenance - Equipment	448.71
VULCAN CONSTRUCTION MATERIALS	STONE	AP070620	4257	Supplies - Other	900.36
VULCAN CONSTRUCTION MATERIALS	STONE	AP070620	4257	Supplies - Other	300.83
WESTERN IRRIGATION	MAINTENANCE-CLOCK TOWER	AP070620	4223	Maintenance - Building	229.00
				Total Public Works, Streets	10,918.49

CITY OF DARIEN
Expenditure Journal
General Fund
Police Department
From 6/16/2020 Through 7/6/2020

Vendor Name	Invoice Description	Session ID	Acct Code	Acct Title	Dept Amount
ADVANCE AUTO PARTS	BRAKE PADS	AP070620	4229	Maintenance - Vehicles	507.52
ADVANCE AUTO PARTS	LIFT SUPPORT- D15	AP070620	4229	Maintenance - Vehicles	64.36
ADVANCE AUTO PARTS	LIFT SUPPORT -D15	AP070620	4229	Maintenance - Vehicles	48.70
ADVANCE AUTO PARTS	RETURN LIFT SUPPORT FOR D15	AP070620	4229	Maintenance - Vehicles	(48.70)
ADVANCE AUTO PARTS	MERCON LV ATF, OIL FILTER FOR SHOP	AP070620	4229	Maintenance - Vehicles	232.28
CHRISTINE CHARKEWYCZ	PROSECUTION FEES - MAY 2020	AP070620	4219	Liability Insurance	224.00
DOLAN CONSULTING GROUP	INV #W1175-16062020-1951... -TRAINING CLASS-CHIEF THOMAS	AP070620	4263	Training and Education	95.00
IL SECRETARY OF STATE	VEHICAL REGISTRATION-D32	AP070620	4229	Maintenance - Vehicles	151.00
IL SECRETARY OF STATE	VEHICAL REGISTRATION-D34	AP070620	4229	Maintenance - Vehicles	151.00
JUST TIRES	STOCK TIRES FOR POLICE DEPT	AP070620	4229	Maintenance - Vehicles	1,375.00
JUST TIRES	TIRE DISPOSAL	AP070620	4229	Maintenance - Vehicles	72.00
KING CAR WASH	CAR WASHES- MAY 2020	AP070620	4229	Maintenance - Vehicles	202.50
MCKESSON MEDICAL-SURGICAL GOVT	FACE MASKS	AP070620	4219	Liability Insurance	518.33
NOTARY PUBLIC ASSOCIATION OF I	NOTARY RENEWAL- LIZ POTERASKE	AP070620	4213	Dues and Subscriptions	54.00
RAY O'HERRON CO. INC.	CSO KOZAK- SHIRT	AP070620	4269	Uniforms	50.00
THOMSON REUTERS -	CLEAR LE-INFORMATION CHARGES	AP070620	4217	Investigation and Equipment	338.32
VERIZON WIRELESS	VERIZON WIRELESS BILL	AP070620	4267	Telephone	756.21
VILLAGE OF LEMONT	RANGE RENTAL FEE 5-6-20	AP070620	4243	Rent - Equipment	100.00
WATCH GUARD DIGITAL	BELTS AND CLIPS FOR VIDEO SURVEILLANCE EQUIPMENT	AP070620	4229	Maintenance - Vehicles	84.00

CITY OF DARIEN
Expenditure Journal
General Fund
Police Department
From 6/16/2020 Through 7/6/2020

<u>Vendor Name</u>	<u>Invoice Description</u>	<u>Session ID</u>	<u>Acct Code</u>	<u>Acct Title</u>	<u>Dept Amount</u>
				Total Police Department	4,975.52
				Total General Fund	46,126.65

CITY OF DARIEN
Expenditure Journal
Water Fund
Public Works, Water
From 6/16/2020 Through 7/6/2020

Vendor Name	Invoice Description	Session ID	Acct Code	Acct Title	Dept Amount
ALWAN PRINTING & PACKAGING	CONSUMER CONFIDENCE REPORTS	AP070620	4231	Maintenance - Water System	1,412.04
ALWAN PRINTING & PACKAGING	CONSUMER CONFIDENCE REPORTS	AP070620	4233	Postage/Mailings	1,400.00
CASE LOTS, INC.	JANITORIAL SUPPLIES	AP070620	4223	Maintenance - Building	224.65
CENTRAL SOD FARMS	SOD FOR RESTORATIONS	AP070620	4231	Maintenance - Water System	432.00
CENTRAL SOD FARMS	SOD FOR RESTORATIONS - 6-4-20	AP070620	4231	Maintenance - Water System	432.00
CENTRAL SOD FARMS	SOD FOR RESTORATIONS-6-2-20	AP070620	4231	Maintenance - Water System	278.00
CENTRAL SOD FARMS	SOD FOR RESTORATIONS 6-9-20 - PALLETS ALREADY RETURNED	AP070620	4231	Maintenance - Water System	288.00
CENTRAL SOD FARMS	SOD FOR RESTORATIONS 6-8-20	AP070620	4231	Maintenance - Water System	432.00
CINTAS FIRST AID AND SAFETY	REPLENISH FIRST AID CABINET	AP070620	4219	Liability Insurance	96.18
COM ED	COM ED 0269155053 2101 W 75TH ST	AP070620	4271	Utilities (Elec,Gas,Wtr,Sewer)	58.15
COM ED	COM ED3118112014 - 2103 75TH ST PUMP	AP070620	4271	Utilities (Elec,Gas,Wtr,Sewer)	394.22
CONSTELLATION NEW ENERGY, INC.	18W736 MANNING RD	AP070620	4271	Utilities (Elec,Gas,Wtr,Sewer)	67.65
CONSTELLATION NEW ENERGY, INC.	67TH RIDGE	AP070620	4271	Utilities (Elec,Gas,Wtr,Sewer)	46.29
CONSTELLATION NEW ENERGY, INC.	0 LAKEVIEW & OAKLEY	AP070620	4271	Utilities (Elec,Gas,Wtr,Sewer)	24.51
CONSTELLATION NEW ENERGY, INC.	1220 PLAINFIELD RD	AP070620	4271	Utilities (Elec,Gas,Wtr,Sewer)	2,022.36
ELMHURST CHICAGO STONE COMPANY	CONCRET FOR SLEEPY HOLLOW /CASS REPAIR	AP070620	4231	Maintenance - Water System	415.50
FIRST ADVANTAGE OCCUPATIONAL	RANDOM DRUG SCREEN	AP070620	4219	Liability Insurance	35.20
GOLDSTAR PRODUCTS INC.	GERMICIDAL WIPES	APVOID062220	4231	Maintenance - Water System	(493.82)
HENDERSON PRODUCTS, INC.	SIDEBOARD FOR #404	AP070620	4225	Maintenance - Equipment	731.80
HOME DEPOT	MAINTENANCE /WATER SYSTEM	AP070620	4231	Maintenance - Water System	343.40

CITY OF DARIEN
Expenditure Journal
Water Fund
Public Works, Water
From 6/16/2020 Through 7/6/2020

Vendor Name	Invoice Description	Session ID	Acct Code	Acct Title	Dept Amount
JAMES KOUDELIK	KOUDELIK- UNIFORM	AP070620	4269	Uniforms	86.78
JSN CONTRACTORS SUPPLY	MARKING PAINT	AP070620	4231	Maintenance - Water System	468.00
KEITH SCHUSTER	REIMBURSEMENT FOR CDL	AP070620	4219	Liability Insurance	61.35
POMP'S TIRE SERVICE, INC.	WATERDOG TRAILER TIRES	AP070620	4225	Maintenance - Equipment	365.30
SHREVE SERVICES INC	TOPSOIL FOR PROJECTS /RESTORATIONS	AP070620	4231	Maintenance - Water System	660.00
SHREVE SERVICES INC	RESTORATIONS	AP070620	4231	Maintenance - Water System	960.00
SHREVE SERVICES INC	DITCH PROJECT: 67TH ST TOPSOIL	AP070620	4231	Maintenance - Water System	320.00
SHREVE SERVICES INC	TOPSOIL FOR PROJECTS /RESTORATIONS	AP070620	4257	Supplies - Other	300.00
TRI-K INC	SANITIZER	AP070620	4219	Liability Insurance	144.50
VERIZON WIRELESS	VERIZON WIRELESS BILL	AP070620	4267	Telephone	542.58
VULCAN CONSTRUCTION MATERIALS	STONE	AP070620	4231	Maintenance - Water System	1,351.93
XBE CHICAGO	TRUCK /DUMP FEES - 6-8-20	AP070620	4231	Maintenance - Water System	1,092.50
ZIEBELL WATER SERVICE PRODUCTS	REPAIR SLEEVES (WATER MAIN CLAMPS)	AP070620	4231	Maintenance - Water System	645.00
				Total Public Works, Water	15,638.07
				Total Water Fund	15,638.07

CITY OF DARIEN
Expenditure Journal
Motor Fuel Tax
MFT Expenses
From 6/16/2020 Through 7/6/2020

<u>Vendor Name</u>	<u>Invoice Description</u>	<u>Session ID</u>	<u>Acct Code</u>	<u>Acct Title</u>	<u>Dept Amount</u>
CONSTELLATION NEW ENERGY, INC.	LITE RT/25 CONTROLLER ST FRONTAGE/CASS	AP070620	4840	Street Lights	17.44
CONSTELLATION NEW ENERGY, INC.	SW CORNER 75TH ST PLAINFIELD RD	AP070620	4840	Street Lights	169.76
CONSTELLATION NEW ENERGY, INC.	0 CASS AVE LITE RT/25 NO OF JAMES PETER CT	AP070620	4840	Street Lights	17.32
EJ USA, INC.	ROAD DRAIN REPAIRS	AP070620	4257	Supplies - Other	3,298.40
NORWALK TANK	ROAD REPAIRS	AP070620	4257	Supplies - Other	1,159.50
ORANGE CRUSH LLC	HMA MODIFIED SURFACE N50	AP070620	4245	Road Material	135.68
ORANGE CRUSH LLC	HMA PRIVATE SURFACE	AP070620	4245	Road Material	364.52
ORANGE CRUSH LLC	HMA PRIVATE SURFACE	AP070620	4245	Road Material	<u>159.12</u>
				Total MFT Expenses	5,321.74
				Total Motor Fuel Tax	<u>5,321.74</u>

CITY OF DARIEN
Expenditure Journal
State Drug Forfeiture Fund
Drug Forfeiture Expenditures
From 6/16/2020 Through 7/6/2020

<u>Vendor Name</u>	<u>Invoice Description</u>	<u>Session ID</u>	<u>Acct Code</u>	<u>Acct Title</u>	<u>Dept Amount</u>
WEX BANK	FUEL FOR POLICE DEPT	AP070620	4273	Vehicle (Gas and Oil)	198.77
				Total Drug Forfeiture Expenditures	198.77
				Total State Drug Forfeiture Fund	198.77

CITY OF DARIEN
Expenditure Journal
Water Depreciation Fund
Depreciation Expenses
From 6/16/2020 Through 7/6/2020

<u>Vendor Name</u>	<u>Invoice Description</u>	<u>Session ID</u>	<u>Acct Code</u>	<u>Acct Title</u>	<u>Dept Amount</u>
DUKES	SMART SHORING EQUIPMENT	AP070620	4390	Capital Improv-Infrastructure	10,600.00
DUKES	LED BALLOON LIGHT	AP070620	4390	Capital Improv-Infrastructure	<u>2,825.00</u>
				Total Depreciation Expenses	<u>13,425.00</u>
				Total Water Depreciation Fund	<u>13,425.00</u>

CITY OF DARIEN
Expenditure Journal
Capital Improvement Fund
Capital Fund Expenditures
From 6/16/2020 Through 7/6/2020

Vendor Name	Invoice Description	Session ID	Acct Code	Acct Title	Dept Amount
BRODERICK HOLDINGS LLC	ECONOMIC INCENTIVE PAYMENT #8	AP070620-3	4400	Economic Incentive	40,000.00
DUPAGE TOPSOIL, INC.	DITCH PROJECT: DIRT FOR 67TH ST	AP070620	4376	Ditch Projects	2,415.00
HOMER TREE CARE, INC.	DITCH PROJECT: TREE REMOVAL/ 6702 BENTLEY	AP070620	4376	Ditch Projects	2,125.00
PORTABLE JOHN	PORTA JOHN = HAND SANITIZER	AP070620	4376	Ditch Projects	164.51
SHREVE SERVICES INC	TOPSOIL FOR 67TH ST DITCH PROJECT	AP070620	4376	Ditch Projects	3,200.00
SHREVE SERVICES INC	TOPSOIL FOR PROJECTS /RESTORATIONS	AP070620	4376	Ditch Projects	320.00
SHREVE SERVICES INC	DITCH PROJECT: 67TH ST TOPSOIL	AP070620	4376	Ditch Projects	1,408.00
XBE CHICAGO	DITCH PROJECT: 67TH ST HAULING (6-9-20)	AP070620	4376	Ditch Projects	997.50
XBE CHICAGO	DITCH PROJECT: 67TH ST HAULING (6-8-20)	AP070620	4376	Ditch Projects	855.00
				Total Capital Fund Expenditures	51,485.01
				Total Capital Improvement Fund	51,485.01
Report Total					132,195.24

CITY OF DARIEN

**EXPENDITURE APPROVAL LIST
FOR CITY COUNCIL MEETING ON
July 20, 2020**

Approval is hereby given to have the City Treasurer of Darien, Illinois pay to the officers, employees, independent contractors, vendors, and other providers of goods and services in the indicated amounts as set forth.

A summary indicating the source of funds used to pay the above is as follows:

General Fund				\$576,905.36
Water Fund				\$489,869.69
Motor Fuel Tax Fund				\$2,258.40
Water Depreciation Fund				
Special Service Area Tax Fund				
E-Citation Fund				
Capital Improvement Fund				76,159.75
State Drug Forfeiture Fund				
Federal Equitable Sharing Fund				
DUI Technology Fund				
			Subtotal:	<u>\$1,145,193.20</u>
General Fund Payroll	07/16/20	\$	234,000.94	
Water Fund Payroll	07/16/20	\$	27,354.45	
		Subtotal:	\$	<u>261,355.39</u>
Total to be Approved by City Council:				<u>\$ 1,406,548.59</u>

Approvals:

Joseph A. Marchese, Mayor

JoAnne E. Ragona, City Clerk

Michael J. Coren, Treasurer

Bryon D. Vana, City Administrator

CITY OF DARIEN
Expenditure Journal
General Fund
Administration
From 7/7/2020 Through 7/20/2020

<u>Vendor Name</u>	<u>Invoice Description</u>	<u>Session ID</u>	<u>Acct Code</u>	<u>Acct Title</u>	<u>Dept Amount</u>
CHASE CARD SERVICES	ZOOM -CITY COUNCIL MEETINGS	AP072020	4213	Dues and Subscriptions	14.99
CHASE CARD SERVICES	TRIBUNE SUBSCRIPTION	AP072020	4213	Dues and Subscriptions	7.96
CHASE CARD SERVICES	FACEBOOK BOOSTER-METRO STRATEGIES	AP072020	4225	Maintenance - Equipment	20.00
CHASE CARD SERVICES	INTERNET FOR PUBLIC WORKS	AP072020	4267	Telephone	113.35
CHRONICLE MEDIA LLC	LEGAL NOTICE: (7-15-20) VARIATION 7700 LYMAN-COM ED	AP072020	4221	Legal Notices	105.00
CLEAN SLATE INC	ADDL CLEANING -CITY HALL	AP072020	4345	Janitorial Service	207.00
CLEAN SLATE INC	JANITORIAL SERVICE-JUNE 2020	AP072020	4345	Janitorial Service	1,456.86
GOVTEMPSUSA LLC	VANA -(6-21-20)	AP072020	4325	Consulting/Professional	3,415.38
GOVTEMPSUSA LLC	VANA -(6-28-20)	AP072020	4325	Consulting/Professional	3,415.38
METRO STRATEGIES	MONTHLY RETAINER-JUNE 2020	AP072020	4239	Public Relations	4,000.00
MUNICIPAL WEB SERVICES	WEBSITE MAINTENANCE - JUNE 2020 and WEBSITE REFRESH	AP072020	4325	Consulting/Professional	1,929.00
ODELSON & STERK LTD	LEGAL FEES- MAY 2020	AP072020	4219	Liability Insurance	1,252.50
OFFICE DEPOT	OFFICE SUPPLIES	AP072020	4253	Supplies - Office	56.58
PM PRINTING INC.	BUSINESS CARDS-THROM AND CHLYSTEK	AP072020	4235	Printing and Forms	101.35
SIKICH PROFESSIONAL SERVICES	AUDIT SERVICES RENDERED THRU 7-3-20	AP072020	4320	Audit	7,800.00
				Total Administration	23,895.35

CITY OF DARIEN
Expenditure Journal
General Fund
Community Development
From 7/7/2020 Through 7/20/2020

Vendor Name	Invoice Description	Session ID	Acct Code	Acct Title	Dept Amount
CHRISTOPHER B. BURKE ENG, LTD	REVIEW PROPOSED POOL IN DETENTION EASEMENT -(8801 GLEN EAG)	AP072020	4328	Const/Prof Reimbursable	942.10
CHRISTOPHER B. BURKE ENG, LTD	COORD W/CITY AND DUPAGE COUNTY - 981 N FRONTAGE RD	AP072020	4328	Const/Prof Reimbursable	165.00
CHRISTOPHER B. BURKE ENG, LTD	REVIEW REAR YARD GRADING - VIOLETS FARM	AP072020	4328	Const/Prof Reimbursable	110.00
CHRISTOPHER B. BURKE ENG, LTD	REVIEW FOUNDATION SPOT SURVEY- 7532 CASS	AP072020	4328	Const/Prof Reimbursable	220.00
DON MORRIS ARCHITECTS P.C.	INSPECTIONS- JUNE 2020	AP072020	4325	Consulting/Professional	4,995.00
DON MORRIS ARCHITECTS P.C.	BUILDING CODE REVIEW - JUNE 2020	AP072020	4328	Const/Prof Reimbursable	5,196.95
DUPAGE LAWN AND HOME SERVICES	LAWN MAINTENANCE- JUNE 2020	AP072020	4328	Const/Prof Reimbursable	800.00
LIZ LAHEY	SECRETARIAL SERVICES: (1-27-20 thru 4-30-20)	AP072020	4205	Boards and Commissions	550.00
LIZ LAHEY	SECRETARIAL SERVICES: (5-1-20 thru 7-12-20)	AP072020	4205	Boards and Commissions	240.00
ODELSON & STERK LTD	LEGAL FEES- MAY 2020	AP072020	4219	Liability Insurance	2,070.00
RETAIL PROPERTIES OF AMERICA	HOME DEPOT ECONOMIC INCENTIVE-2020 DARIEN IL	AP072020	4240	Economic Development	68,000.00
SEBERT LANDSCAPING	LAWN MAINTENANCE -6726 LEONARD	AP072020	4328	Const/Prof Reimbursable	240.00
SEBERT LANDSCAPING	LAWN MAINTENANCE -2019 75TH ST	AP072020	4328	Const/Prof Reimbursable	240.00

**CITY OF DARIEN
Expenditure Journal
General Fund
Community Development
From 7/7/2020 Through 7/20/2020**

<u>Vendor Name</u>	<u>Invoice Description</u>	<u>Session ID</u>	<u>Acct Code</u>	<u>Acct Title</u>	<u>Dept Amount</u>
SEBERT LANDSCAPING	LAWN MAINTENANCE -337 ROGER RD	AP072020	4328	Const/Prof Reimbursable	240.00
WAL-MART	WALMART ECONOMIC DEVELOPMENT INCENTIVE-2020	AP072020	4240	Economic Development	286,546.93
				Total Community Development	370,555.98

CITY OF DARIEN
Expenditure Journal
General Fund
Public Works, Streets
From 7/7/2020 Through 7/20/2020

Vendor Name	Invoice Description	Session ID	Acct Code	Acct Title	Dept Amount
ADVANCE AUTO PARTS	LUBE	AP072020	4225	Maintenance - Equipment	26.82
ADVANCE AUTO PARTS	BT PLUS 12V	AP072020	4225	Maintenance - Equipment	46.89
ADVANCE AUTO PARTS	OIL FILTER	AP072020	4225	Maintenance - Equipment	24.09
ADVANCE AUTO PARTS	BELT FOR 308	AP072020	4225	Maintenance - Equipment	19.30
ADVANCE AUTO PARTS	AIR FILTERS- 304	AP072020	4229	Maintenance - Vehicles	37.80
ADVANCE AUTO PARTS	AIR FILTERS- 313	AP072020	4229	Maintenance - Vehicles	37.80
ADVANCE AUTO PARTS	AIR FILTERS- 314	AP072020	4229	Maintenance - Vehicles	37.80
ADVANCE AUTO PARTS	RETURN CREDIT FOR INV 771688	AP072020	4229	Maintenance - Vehicles	(123.04)
ADVANCE AUTO PARTS	AIR FILTER FOR SHOP	AP072020	4229	Maintenance - Vehicles	123.04
ADVANCE AUTO PARTS	HEX DIE	AP072020	4229	Maintenance - Vehicles	6.24
ADVANCE AUTO PARTS	BELT FOR SHOP	AP072020	4229	Maintenance - Vehicles	19.30
ADVANCE AUTO PARTS	RETURN FOR INV 769401	AP072020	4229	Maintenance - Vehicles	(19.30)
ADVANCE AUTO PARTS	BRAKES FOR 502	AP072020	4229	Maintenance - Vehicles	324.54
AIR ONE EQUIPMENT, INC.	HARD HATS	AP072020	4219	Liability Insurance	309.75
AMBER MECHANICAL CONTRACTORS	COMPRESSORS FOR POLICE DEPT	AP072020	4223	Maintenance - Building	724.00
AMBER MECHANICAL CONTRACTORS	POLICE DEPT GENERATOR	AP072020	4223	Maintenance - Building	3,067.00
BANNERVILLE USA INC	REPLACEMENT BANNERS	AP072020	4223	Maintenance - Building	975.00
CENTRAL SOD FARMS	SOD FOR RESTORATION	AP072020	4257	Supplies - Other	154.00
CENTRAL SOD FARMS	SOD FOR RESTORATIONS	AP072020-2	4257	Supplies - Other	144.00
CENTRAL SOD FARMS	CREDIT FOR VOIDED CK 055298	APCREDIT072...	4257	Supplies - Other	(154.00)
CHASE CARD SERVICES	DISPLAY STAND FOR SIGNAGE	AP072020	4223	Maintenance - Building	104.94
CHASE CARD SERVICES	SOLAR LIGHTS FOR AMERICAN FLAG DISPLAY	AP072020	4223	Maintenance - Building	291.96
CHASE CARD SERVICES	LICENSE PLATE RENEWAL- GOMBAC	AP072020	4229	Maintenance - Vehicles	154.40

CITY OF DARIEN
Expenditure Journal
General Fund
Public Works, Streets
From 7/7/2020 Through 7/20/2020

Vendor Name	Invoice Description	Session ID	Acct Code	Acct Title	Dept Amount
CHASE CARD SERVICES	4TH OF JULY DECOR- MAYOR MARCHESE	AP072020	4257	Supplies - Other	377.48
CHASE CARD SERVICES	4TH OF JULY DECOR - MAYOR MARCHESE	AP072020	4257	Supplies - Other	97.50
CHRISTOPHER B. BURKE ENG, LTD	UTILITY POLE IN WETLAND BUFFER	AP072020	4325	Consulting/Professional	220.00
CHRISTOPHER B. BURKE ENG, LTD	DRAINAGE CONCERNS- DARIEN CLUB	AP072020	4325	Consulting/Professional	330.00
CINTAS #769	MATT RENTAL- PUBLIC WORKS	AP072020	4223	Maintenance - Building	50.87
CINTAS #769	MATT RENTAL- POLICE DEPT	AP072020	4223	Maintenance - Building	49.70
CINTAS #769	MATT RENTAL- CITY HALL	AP072020	4223	Maintenance - Building	44.83
CLARKE ENVIRONMENTAL MOSQUITO	MOSQUITO MANAGEMENT- FINAL PAYMENT (4 of 4)	AP072020	4365	Mosquito Abatement	10,425.00
CLEAN SLATE INC	ADDL CLEANING -CITY HALL	AP072020	4223	Maintenance - Building	1,182.00
CONSTELLATION NEW ENERGY, INC.	75TH ST LEGS STR LGT 0 CASS AVE	AP072020	4271	Utilities (Elec,Gas,Wtr,Sewer)	198.95
ETERNALLY GREEN	75th ST MEDIANS (PLAINFIELD /CASS)	AP072020	4350	Forestry	2,725.00
ETERNALLY GREEN	MAINTENANCE-CH & PD	AP072020	4350	Forestry	36.50
ETERNALLY GREEN	MAINTENANCE- PW	AP072020	4350	Forestry	88.00
ETERNALLY GREEN	MAINTENANCE- BASINS	AP072020	4350	Forestry	1,725.00
ETERNALLY GREEN	MAINTENANCE-CLOCK TOWER TURF	AP072020	4350	Forestry	45.00
FULTON SIREN SERVICES	WARNING SIREN MONITORING	AP072020	4223	Maintenance - Building	397.35
HINSDALE NURSERIES INC.	LANDSCAPE SUPPLIES	AP072020	4257	Supplies - Other	121.98
HOME DEPOT	MAINTENANCE SUPPLIES AND TOOLS	AP072020	4223	Maintenance - Building	436.66
HOME DEPOT	MAINTENANCE SUPPLIES AND TOOLS	AP072020	4257	Supplies - Other	586.24

CITY OF DARIEN
Expenditure Journal
General Fund
Public Works, Streets
From 7/7/2020 Through 7/20/2020

Vendor Name	Invoice Description	Session ID	Acct Code	Acct Title	Dept Amount
HOME DEPOT	MAINTENANCE SUPPLIES AND TOOLS	AP072020	4257	Supplies - Other	185.05
HOME DEPOT	MAINTENANCE SUPPLIES AND TOOLS	AP072020	4257	Supplies - Other	(3.53)
HOME DEPOT	MAINTENANCE SUPPLIES AND TOOLS	AP072020	4375	Tree Trim/Removal	208.67
INTERSTATE BILLING SERVICE INC	TRUCK REPAIR PARTS	AP072020	4229	Maintenance - Vehicles	535.00
JC LANDSCAPING/TREE SERVICE	526 71st STORM INLET	AP072020	4374	Drainage Projects	720.00
KAMAN FLUID POWER LLC	HOSES	AP072020	4223	Maintenance - Building	287.61
KINNUCAN COMPANY	EAB TREATMENT	AP072020	4375	Tree Trim/Removal	127,681.70
LAWSON PRODUCTS INCORPORATED	MECHANIC SUPPLIES	AP072020	4225	Maintenance - Equipment	498.05
MID-TOWN ACQUISITION -RELADYNE	DEF	AP072020	4229	Maintenance - Vehicles	179.90
NICOR GAS	NICOR 90841110001 - 1041 S FRONTAGE RD	AP072020	4271	Utilities (Elec,Gas,Wtr,Sewer)	63.61
NICOR GAS	NICOR 23644110001 8600 LEMONT RD	AP072020	4271	Utilities (Elec,Gas,Wtr,Sewer)	22.64
OCCUPATIONAL HEALTH CENTERS	RANDOM DRUG SCREEN	AP072020	4219	Liability Insurance	40.50
RAGS ELECTRIC	LAMPS AND FIXTURES FOR POLICE DEPT	AP072020	4223	Maintenance - Building	1,636.50
SEBERT LANDSCAPING	LANDSCAPE MAINTENANCE- JULY 2020-75th St Planters	AP072020	4350	Forestry	4,741.66
SEBERT LANDSCAPING	LANDSCAPE MAINTENANCE- JULY 2020 -ENTRANCE SIGNS	AP072020	4350	Forestry	985.00
SEBERT LANDSCAPING	LANDSCAPE MAINTENANCE- JULY 2020 -CLOCK TOWER	AP072020	4350	Forestry	2,635.66
SEBERT LANDSCAPING	LANDSCAPE MAINTENANCE- JULY 2020 - CITY HALL COMPLEX	AP072020	4350	Forestry	2,612.33
SHREVE SERVICES INC	TOPSOIL	AP072020	4257	Supplies - Other	320.00
THE HIDDEN GARDENS	TREE REPLACEMENT	AP072020	4350	Forestry	395.00

CITY OF DARIEN
Expenditure Journal
General Fund
Public Works, Streets
From 7/7/2020 Through 7/20/2020

<u>Vendor Name</u>	<u>Invoice Description</u>	<u>Session ID</u>	<u>Acct Code</u>	<u>Acct Title</u>	<u>Dept Amount</u>
TRAFFIC CONTROL AND PROTECTION	SIGN MATERIALS	AP072020	4257	Supplies - Other	125.00
UNIQUE PRODUCTS & SERVICE CORP	JANITORIAL SUPPLIES FOR POLICE DEPT	AP072020	4223	Maintenance - Building	89.85
US GAS	GAS CYLINDER RENTAL	AP072020	4257	Supplies - Other	50.40
WESTERN IRRIGATION	CLOCK TOWER SPRINKLER	AP072020	4223	Maintenance - Building	314.85
WESTOWN AUTO SUPPLY COMPANY	REPAIR PARTS	AP072020	4229	Maintenance - Vehicles	13.84
WESTOWN AUTO SUPPLY COMPANY	REPAIR PARTS	AP072020	4229	Maintenance - Vehicles	129.50
				Total Public Works, Streets	169,939.18

CITY OF DARIEN
Expenditure Journal
General Fund
Police Department
From 7/7/2020 Through 7/20/2020

Vendor Name	Invoice Description	Session ID	Acct Code	Acct Title	Dept Amount
ADVANCE AUTO PARTS	BRAKES FOR D6	AP072020	4229	Maintenance - Vehicles	192.77
ADVANCE AUTO PARTS	BRAKES FOR D4	AP072020	4229	Maintenance - Vehicles	192.77
ADVANCE AUTO PARTS	BRAKE PADS FOR SHOP	AP072020	4229	Maintenance - Vehicles	567.58
ADVANCE AUTO PARTS	FLOOR JACK	AP072020	4229	Maintenance - Vehicles	167.43
ADVANCE AUTO PARTS	BRAKES FOR D32	AP072020	4229	Maintenance - Vehicles	284.64
BANK AMERICA	SUBPOENA PROCESSING FEE (DE5-024-02-08)	AP072020	4217	Investigation and Equipment	30.00
BAZOS FREEMAN LLC	ADMIN TOW JUDGE FEE - JUNE 2020	AP072020	4219	Liability Insurance	200.00
CHASE CARD SERVICES	ARMORY SUPPLIES	AP072020	4217	Investigation and Equipment	18.45
CHASE CARD SERVICES	CLIPS FOR EVIDENCE ROOM	AP072020	4217	Investigation and Equipment	6.00
CHASE CARD SERVICES	MICROWAVE FOR POLICE DEPT	AP072020	4225	Maintenance - Equipment	194.39
CHASE CARD SERVICES	TONER	AP072020	4253	Supplies - Office	66.00
CHASE CARD SERVICES	CD SLEEVES AND BATTERIES	AP072020	4253	Supplies - Office	43.46
CHASE CARD SERVICES	CD FOR RECORDS DEPT	AP072020	4253	Supplies - Office	45.78
CHASE CARD SERVICES	DOCUMENT COVERS	AP072020	4253	Supplies - Office	25.84
CHASE CARD SERVICES	SODA FOR RENTKA RETIREMENT PARTY	AP072020	4265	Travel/Meetings	11.28
CHASE CARD SERVICES	INTERNET FOR POLICE DEPT	AP072020	4267	Telephone	268.35
CHRISTINE CHARKEWYCZ	PROSECUTION FEES- JUNE 2020	AP072020	4219	Liability Insurance	745.00
CLEAN SLATE INC	ADDL CLEANING -CITY HALL	AP072020	4225	Maintenance - Equipment	952.00
EMERGENCY VEHICLE TECHNOLOGIES	RADIO INSTALL - D37	AP072020	4229	Maintenance - Vehicles	464.60
I.R.M.A.	JUNE 2020 DEDUCTIBLE - JAIRALA CLAIM	AP072020	4219	Liability Insurance	1,016.00
IL SECRETARY OF STATE	VEHICLE REGISTRATION - D37	AP072020	4229	Maintenance - Vehicles	151.00
IL SECRETARY OF STATE	VEHICLE REGISTRATION - D38	AP072020	4229	Maintenance - Vehicles	151.00

CITY OF DARIEN
Expenditure Journal
General Fund
Police Department
From 7/7/2020 Through 7/20/2020

Vendor Name	Invoice Description	Session ID	Acct Code	Acct Title	Dept Amount
KING CAR WASH	CAR WASHES- JUNE 2020	AP072020	4229	Maintenance - Vehicles	233.50
LAW ENFORCEMENT RECORDS MGRS	KIM WRIGHT - LERMIT MEMBERSHIP	AP072020	4213	Dues and Subscriptions	15.00
LEADS ONLINE	TOTAL TRACK INVESTIGATION SYSTEM	AP072020	4217	Investigation and Equipment	2,305.00
LERMI	LERMIT MEMBERSHIP RENEWAL - ROSE GONZALEZ	AP072020	4213	Dues and Subscriptions	25.00
NICOR GAS	NICOR 82800010009 1710 PLAINFIELD RD	AP072020	4271	Utilities (Elec,Gas,Wtr,Sewer)	363.44
ODELSON & STERK LTD	LEGAL FEES- MAY 2020	AP072020	4219	Liability Insurance	1,925.00
RAY O'HERRON CO. INC.	NORTON- DEPUTY CHIEF NORTON	AP072020	4269	Uniforms	23.74
RAY O'HERRON CO. INC.	NELSON- HOLSTER	AP072020	4269	Uniforms	43.99
ROCK RIVER ARMS, INC.	RIFLE REPAIR	AP072020	4217	Investigation and Equipment	42.90
STORINO, RAMELLO & DURKIN	LAWYER- BOZEK APPEAL	AP072020	4219	Liability Insurance	352.00
THOMSON REUTERS -	CLEAR LE CHARGES	AP072020	4217	Investigation and Equipment	338.32
TKB ASSOCIATES INC	LASERFICHE- MAINTENANCE, SUPPORT, RENEWAL	AP072020	4225	Maintenance - Equipment	642.00
TRI TECH FORENSICS	EVIDENCE COLLECTION KIT	AP072020	4217	Investigation and Equipment	129.62
VILLAGE OF LEMONT	RANGE RENTAL (June 17 and 30, 2020)	AP072020	4243	Rent - Equipment	200.00
WATCH GUARD VIDEO	VIDEO CLIPS	AP072020	4229	Maintenance - Vehicles	81.00
				Total Police Department	12,514.85
				Total General Fund	576,905.36

CITY OF DARIEN
Expenditure Journal
Water Fund
Public Works, Water
From 7/7/2020 Through 7/20/2020

Vendor Name	Invoice Description	Session ID	Acct Code	Acct Title	Dept Amount
ADVANCE AUTO PARTS	POWER PACK	AP072020	4225	Maintenance - Equipment	116.00
ADVANCE AUTO PARTS	FUEL SPIN	AP072020	4225	Maintenance - Equipment	10.06
AIR ONE EQUIPMENT, INC.	HARD HATS	AP072020	4219	Liability Insurance	309.75
BLUE-WHITE INDUSTRIES	CHLORINE PUMPS	AP072020	4231	Maintenance - Water System	560.72
CARROLL CONSTRUCTION SUPPLY	SAW BLADES	AP072020	4231	Maintenance - Water System	662.51
CENTRAL SOD FARMS	BLUEGRASS SOD	AP072020	4231	Maintenance - Water System	154.00
CENTRAL SOD FARMS	BLUEGRASS SOD	AP072020	4231	Maintenance - Water System	144.00
CENTRAL SOD FARMS	BLUEGRASS SOD	AP072020-2	4231	Maintenance - Water System	144.00
CENTRAL SOD FARMS	BLUEGRASS SOD	AP072020-2	4231	Maintenance - Water System	144.00
CENTRAL SOD FARMS	CREDIT FOR VOIDED CK 055298	APCREDIT072...	4231	Maintenance - Water System	(154.00)
CENTRAL SOD FARMS	CREDIT FOR VOIDED CK 055298	APCREDIT072...	4231	Maintenance - Water System	(144.00)
CHASE CARD SERVICES	AUTO PARTS FOR PW MECHANIC	AP072020	4225	Maintenance - Equipment	66.91
CHASE CARD SERVICES	TUBES ROLLER ASSEMBLY FOR PW	AP072020	4231	Maintenance - Water System	737.71
CLEAN SLATE INC	JANITORIAL SERVICE- JUNE 2020	AP072020	4223	Maintenance - Building	485.62
CLEAN SLATE INC	ADDL CLEANING -CITY HALL	AP072020	4223	Maintenance - Building	914.00
CORE & MAIN	WIRE & CPLG	AP072020	4231	Maintenance - Water System	943.71
CORE & MAIN	B-BOX LIDS	AP072020	4231	Maintenance - Water System	363.00
DIESEL SERVICE CENTER	CHECK AND ADVISE - TRUCK #402	AP072020	4225	Maintenance - Equipment	167.74
DUPAGE COUNTY PUBLIC WORKS	METER READINGS	AP072020	4336	Data Processing	26,696.75
DUPAGE WATER COMMISSION	WATER PURCHASE	AP072020	4340	DuPage Water Commission	442,205.75
ETERNALLY GREEN	FERTILIZATION- CH &PD	AP072020	4223	Maintenance - Building	36.50
ETERNALLY GREEN	FERTILIZATION -PW	AP072020	4223	Maintenance - Building	349.00
HACH COMPANY	CHLORINE ANALYZER AGREEMENT	AP072020	4255	Supplies - Operation	1,428.00
KAMAN FLUID POWER LLC	HOSES	AP072020	4223	Maintenance - Building	287.60
NICOR GAS	NICOR 12344110007 1897 MANNING	AP072020	4271	Utilities (Elec,Gas,Wtr,Sewer)	38.37

CITY OF DARIEN
Expenditure Journal
Water Fund
Public Works, Water
From 7/7/2020 Through 7/20/2020

Vendor Name	Invoice Description	Session ID	Acct Code	Acct Title	Dept Amount
NICOR GAS	NICOR 90841110001 - 1041 S FRONTAGE RD	AP072020	4271	Utilities (Elec,Gas,Wtr,Sewer)	63.60
NICOR GAS	NICOR 23644110001 8600 LEMONT RD	AP072020	4271	Utilities (Elec,Gas,Wtr,Sewer)	22.64
NICOR GAS	NICOR GAS 05002110004 1930 MANNING RD	AP072020	4271	Utilities (Elec,Gas,Wtr,Sewer)	48.47
RENDELS INC	TRUCK REPAIR FOR #402	AP072020	4225	Maintenance - Equipment	33.18
RENDELS INC	TRUCK REPAIR FOR #402	AP072020	4225	Maintenance - Equipment	1,777.69
RENDELS INC	TRUCK REPAIR FOR #402	AP072020	4225	Maintenance - Equipment	300.00
RENDELS INC	CORE RETURN FOR INV 101153	AP072020	4225	Maintenance - Equipment	(300.00)
SIKICH PROFESSIONAL SERVICES	AUDIT SERVICES RENDERED THRU 7-3-20	AP072020	4320	Audit	10,200.00
SUBURBAN LABORATORIES	WATER SAMPLES	AP072020	4241	Quality Control	870.00
US GAS	GAS CYLINDER RENTAL	AP072020	4231	Maintenance - Water System	50.40
WILLOWBROOK FORD, INC.	VECHICLE MAINTENANCE #404	AP072020	4225	Maintenance - Equipment	64.10
WILLOWBROOK FORD, INC.	VEHICLE MAINTENANCE ON #400	AP072020	4225	Maintenance - Equipment	8.44
WILLOWBROOK FORD, INC.	SWITCH ASY FOR #400	AP072020	4225	Maintenance - Equipment	63.47
				Total Public Works, Water	489,869.69
				Total Water Fund	489,869.69

CITY OF DARIEN
Expenditure Journal
Motor Fuel Tax
MFT Expenses
From 7/7/2020 Through 7/20/2020

<u>Vendor Name</u>	<u>Invoice Description</u>	<u>Session ID</u>	<u>Acct Code</u>	<u>Acct Title</u>	<u>Dept Amount</u>
CONSTELLATION NEW ENERGY, INC.	SW CORNER 75TH ST /ADAMS	AP072020	4840	Street Lights	2,032.58
CONSTELLATION NEW ENERGY, INC.	LITE RT/25 CONTRLR S FRONTA 0-E CASS ST	AP072020	4840	Street Lights	18.68
CONSTELLATION NEW ENERGY, INC.	SW CORNER 75TH ST/PLAINFIELD RD	AP072020	4840	Street Lights	103.66
ORANGE CRUSH LLC	HMA PRIVATE SURFACE	AP072020	4245	Road Material	<u>103.48</u>
				Total MFT Expenses	<u>2,258.40</u>
				Total Motor Fuel Tax	<u>2,258.40</u>

CITY OF DARIEN
Expenditure Journal
Capital Improvement Fund
Capital Fund Expenditures
From 7/7/2020 Through 7/20/2020

<u>Vendor Name</u>	<u>Invoice Description</u>	<u>Session ID</u>	<u>Acct Code</u>	<u>Acct Title</u>	<u>Dept Amount</u>
CHRISTOPHER B. BURKE ENG, LTD	2020 ROAD PROGRAM DESIGN	AP072020	4325	Consulting/Professional	1,395.00
JC LANDSCAPING/TREE SERVICE	DITCH PROJECT: ELM ST LANDSCAPE	AP072020	4376	Ditch Projects	756.00
JC LANDSCAPING/TREE SERVICE	DITCH PROJECT: 67TH ST LANDSCAPE	AP072020	4376	Ditch Projects	35,778.00
SCORPIO CONSTRUCTION CORP	DITCH PROGRAM- 67TH ST FLAGGER	AP072020	4376	Ditch Projects	36,069.00
WILLCO GREEN LLC	DITCH PROJECT: 67TH ST HAULING (6-8 and 6-9-20)	AP072020	4376	Ditch Projects	1,188.00
XBE CHICAGO	DITCH PROJECT: YARD CLEAN UP (6-8-20)	AP072020	4376	Ditch Projects	973.75
				Total Capital Fund Expenditures	76,159.75
				Total Capital Improvement Fund	76,159.75
Report Total					1,145,193.20



ACCOUNT ACTIVITY

Date of Transaction	Merchant Name or Transaction Description	\$ Amount
06/17	Payment Thank You - Web BRYON VANA TRANSACTIONS THIS CYCLE (CARD 4484) \$5532.33- INCLUDING PAYMENTS RECEIVED	-5,532.33
06/09	FACEBK AXV93SWG92 650-5434800 CA <i>BOOSTER</i> MARY BELMONTE TRANSACTIONS THIS CYCLE (CARD 8706) \$20.00	20.00
06/07	COMCAST CHICAGO 800-COMCAST IL <i>POLICE DEPT INTERNET</i>	268.95
06/05	STAPLS7308130427000001 877-8267755 MI <i>DOCUMENT COVERS</i>	25.84
06/12	BESTBUYCOM806126626182 888-BESTBUY MN <i>MICROWAVE (PB)</i>	194.99
06/18	STAPLS7308842422000001 877-8267755 MI <i>TONER</i>	66.00
06/19	AMZN Mktp US*MS0NX1XR1 Amzn.com/bill WA <i>CD SLEEVES-BATTERIES</i>	43.46
06/26	STAPLS7309219595000001 877-8267755 MI <i>CD'S FOR RECORDS DEPT</i> ROSE MARY GONZALEZ TRANSACTIONS THIS CYCLE (CARD 2755) \$643.82	45.78
06/02	AMZN Mktp US*MY2CL4380 Amzn.com/bill WA <i>STANDS FOR SIGNAGE</i>	104.94
06/03	ZOOM.US 888-799-9666 CA <i>CITY COUNCIL MEETINGS</i>	14.99
06/05	HLSUPPLY 386-256-4891 FL <i>AUTO PARTS - MASEK</i>	66.91
06/18	ILSOS INT VEH RENEWAL 8667566041 IL <i>GOMBAC LICENSE PLATE</i>	154.40
06/19	BLUE-WHITE IND ECOMM 714-893-8529 CA <i>PW-ROLLER ASSY</i>	737.71
06/22	COMCAST CHICAGO 800-COMCAST IL <i>PUBLIC WORKS INTERNET</i>	113.35
06/22	CHICAGO TRIB SUBSCRIPTIO 312-546-7900 TX <i>NEWSPAPER</i>	7.96
06/24	AMZN Mktp US*MS6HU98D0 Amzn.com/bill WA <i>July 4th DECOR</i>	97.50
06/25	AMZN Mktp US*MS9427B22 Amzn.com/bill WA	377.48
06/26	AMZN Mktp US*MS21372E0 Amzn.com/bill WA <i>SOLAR LIGHTS</i> DANIEL GOMBAC TRANSACTIONS THIS CYCLE (CARD 8085) \$1967.20	291.96
06/08	DOLLAR TREE DOWNERS GROVE IL <i>CLIPS FOR EVIDENCE RM</i>	6.00
06/22	LA HUERTA #6 WESTMONT IL <i>SODA- RENTKA RETIRED</i>	11.28
07/01	WAL-MART #2216 DARIEN IL <i>ARMORY SUPPLIES</i> THERESA ESTRADA TRANSACTIONS THIS CYCLE (CARD 8231) \$35.73	18.45

2020 Totals Year-to-Date	
Total fees charged in 2020	\$0.00
Total interest charged in 2020	\$0.00

Year-to-date totals do not reflect any fee or interest refunds you may have received.

INTEREST CHARGES

Your Annual Percentage Rate (APR) is the annual interest rate on your account.

Balance Type	Annual Percentage Rate (APR)	Balance Subject To Interest Rate	Interest Charges
PURCHASES			
Purchases	13.24%(v)(d)	- 0 -	- 0 -

BUSINESS CARD STATEMENT



Customer Service:
1-800-275-0863



Mobile: Download the
Chase Mobile® app today

July 2020						
S	M	T	W	T	F	S
28	29	30	1	2	3	4
5	6	7	8	9	10	11
12	13	14	15	16	17	18
19	20	21	22	23	24	25
26	27	28	29	30	31	1
2	3	4	5	6	7	8

New Balance
\$2,666.75
Minimum Payment Due
\$533.00
Payment Due Date
07/24/20

Late Payment Warning: If we do not receive your minimum payment by the due date, you may have to pay a late fee, and existing and new balances may become subject to the Default APR.
Minimum Payment Warning: Enroll in Auto-Pay and avoid missing a payment. To enroll, go to www.chase.com

ACCOUNT SUMMARY

Previous Balance	\$5,532.33
Payment, Credits	-\$5,532.33
Purchases	+\$2,666.75
Cash Advances	\$0.00
Balance Transfers	\$0.00
Fees Charged	\$0.00
Interest Charged	\$0.00
New Balance	\$2,666.75
Opening/Closing Date	06/03/20 - 07/02/20
Credit Limit	\$50,000
Available Credit	\$47,333
Cash Access Line	\$10,000
Available for Cash	\$10,000
Past Due Amount	\$0.00
Balance over the Credit Limit	\$0.00

AGENDA MEMO
City Council
July 20, 2020

ISSUE STATEMENT

An ordinance amending various sections of Title 8, “Police Regulations,” Chapter 20 “Drug Paraphernalia” of the City of Darien city code.

ORDINANCE

BACKGROUND HISTORY

Staff is recommending several changes to Chapter 20 “Drug Paraphernalia” ordinance. A change to the State law regarding recreational marijuana came into law 01/01/2020 which requires updating to the City of Darien’s ordinances.

A [redline copy](#) and a [clean copy](#) of proposed changes are attached.

STAFF/COMMITTEE RECOMMENDATION

Committee recommends approval of an ordinance updating the ordinance regarding Drug Paraphernalia.

ALTERNATE CONSIDERATION

As directed.

DECISION MODE

This item will be on the July 20, 2020, City Council agenda for formal approval.

Chapter 20 DRUG PARAPHERNALIA

8-20-1 DEFINITIONS

8-20-2 POSSESSION OF DRUG PARAPHERNALIA

8-20-3 PENALTY

8-20-1 DEFINITIONS

CANNABIS: Shall have the meaning ascribed to it in [Chapter 7 section 3](#) of the "Cannabis [Control Act](#)¹ Regulation", as if that definition were incorporated herein.

CONTROLLED SUBSTANCE: Shall have the meaning ascribed to it in section 102 of the "Illinois Controlled Substances Act"², as if that definition were incorporated herein.

DRUG PARAPHERNALIA: All equipment, products and materials of any kind which are peculiar to or adapted for use in planting, growing, harvesting, manufacturing, producing, processing, preparing, testing, analyzing, packaging, storing, concealing, injecting, ingesting, inhaling, or otherwise introducing into the human body cannabis or a controlled substance in violation of the Cannabis Control Act, the Illinois Controlled Substances Act, [Chapter 7](#) of this Title, or similar law or local ordinance.

Drug paraphernalia shall include, but not be limited to: water, ice, air-driven, or electric pipes; miniature cocaine spoons or vials; smoking or carburetion pipes, tubes, masks, or other devices; bongs; roach clips; or any item whose purpose, as announced or described by the possessor, or whose actual use as determined by the presence of a controlled substance on, in or near the item, is for use in violating the Cannabis Control Act, the Illinois Controlled Substances Act, [Chapter 7](#) of this Title, or similar law or local ordinance. (Ord. 0-26-98, 12-7-1998)

8-20-2 POSSESSION OF DRUG PARAPHERNALIA

No person [under the age of 21](#) shall knowingly possess an item of drug paraphernalia with the intent to use it in ingesting, inhaling, or otherwise introducing cannabis [or a controlled substance](#) into the human body, or in preparing cannabis [or a controlled substance](#) for that use.

[No person shall knowingly possess an item of drug paraphernalia with the intent to use it in ingesting, inhaling, or otherwise introducing a controlled substance into the human body, or in preparing a controlled substance for that use.](#)

In determining use or intent under this Section, the trier of fact can take into consideration the general, usual, customary and historical use to which the item involved has been put, and/or the proximity of the cannabis or controlled substance to the drug paraphernalia or the presence of cannabis or controlled substance on the drug paraphernalia. (Ord. 0-26-98, 12-7-1998)

8-20-3 PENALTY

Any person found guilty by a court of competent jurisdiction of having violated Section [8-20-2](#) of this Chapter shall be fined not less than one hundred dollars (\$100.00) nor more than ~~seven~~ ~~five~~ hundred ~~fifty~~ dollars (~~\$750.00~~ \$500.00). (Ord. 0-26-98, 12-7-1998)

Footnotes - Click any footnote link to go back to its reference.

[Footnote 1](#): 720 ILCS 550/3.

Chapter 20 DRUG PARAPHERNALIA

8-20-1 DEFINITIONS

8-20-2 POSSESSION OF DRUG PARAPHERNALIA

8-20-3 PENALTY

8-20-1 DEFINITIONS

CANNABIS: Shall have the meaning ascribed to it in Chapter 7 of the "Cannabis Regulation", as if that definition were incorporated herein.

CONTROLLED SUBSTANCE: Shall have the meaning ascribed to it in section 102 of the "Illinois Controlled Substances Act"², as if that definition were incorporated herein.

DRUG PARAPHERNALIA: All equipment, products and materials of any kind which are peculiar to or adapted for use in planting, growing, harvesting, manufacturing, producing, processing, preparing, testing, analyzing, packaging, storing, concealing, injecting, ingesting, inhaling, or otherwise introducing into the human body cannabis or a controlled substance in violation of the Cannabis Control Act, the Illinois Controlled Substances Act, [Chapter 7](#) of this Title, or similar law or local ordinance.

Drug paraphernalia shall include, but not be limited to: water, ice, air-driven, or electric pipes; miniature cocaine spoons or vials; smoking or carburetion pipes, tubes, masks, or other devices; bongs; roach clips; or any item whose purpose, as announced or described by the possessor, or whose actual use as determined by the presence of a controlled substance on, in or near the item, is for use in violating the Cannabis Control Act, the Illinois Controlled Substances Act, [Chapter 7](#) of this Title, or similar law or local ordinance. (Ord. 0-26-98, 12-7-1998)

8-20-2 POSSESSION OF DRUG PARAPHERNALIA

No person under the age of 21 shall knowingly possess an item of drug paraphernalia with the intent to use it in ingesting, inhaling, or otherwise introducing cannabis into the human body, or in preparing cannabis for that use.

No person shall knowingly possess an item of drug paraphernalia with the intent to use it in ingesting, inhaling, or otherwise introducing a controlled substance into the human body, or in preparing a controlled substance for that use.

In determining use or intent under this Section, the trier of fact can take into consideration the general, usual, customary and historical use to which the item involved has been put, and/or the proximity of the cannabis or controlled substance to the drug paraphernalia or the presence of cannabis or controlled substance on the drug paraphernalia. (Ord. 0-26-98, 12-7-1998)

8-20-3 PENALTY

Any person found guilty by a court of competent jurisdiction of having violated Section [8-20-2](#) of this Chapter shall be fined not less than one hundred dollars (\$100.00) nor more than five hundred dollars (\$500.00). (Ord. 0-26-98, 12-7-1998)

Footnotes - Click any footnote link to go back to its reference.

[Footnote 1](#): 720 ILCS 550/3.



CITY OF DARIEN

DU PAGE COUNTY, ILLINOIS

ORDINANCE NO. _____

AN ORDINANCE REPLACING
TITLE 8 (POLICE REGULATIONS)
CHAPTER 20 (DRUG PARAPHERNALIA)
OF THE CITY OF DARIEN CITY CODE

ADOPTED BY THE
MAYOR AND CITY COUNCIL
OF THE CITY OF DARIEN

THIS 20th DAY OF JULY, 2020

**Published in pamphlet form by authority
of the Mayor and City Council of the City
of Darien, DuPage County, Illinois, this ___
_____ day of July 2020.**

ORDINANCE NO. _____

AN ORDINANCE REPLACING TITLE 8, CHAPTER 20, "DRUG PARAPHERNALIA" OF THE CITY OF DARIEN CITY CODE

BE IT ORDAINED BY THE CITY COUNCIL OF THE CITY OF DARIEN, DUPAGE COUNTY, ILLINOIS, IN THE EXERCISE OF ITS HOME RULE POWERS, as follows:

WHEREAS, changes have been made to the Illinois Compiled Statutes relating to cannabis offenses; and

WHEREAS, a portion of Chapter 20 of Title 8 of the Darien City Code is no longer consistent with State statutes; and WHEREAS, a revision of the cannabis related violations in Chapter 20 of Title 8 of the Darien City Code is now appropriate;

NOW, THEREFORE, BE IT ORDAINED BY THE CITY COUNCIL OF THE CITY OF DARIEN, DUPAGE COUNTY, ILLINOIS, IN THE EXERCISE OF ITS HOME RULE POWERS, as follows:

SECTION 1: That Chapter 20 of Title 8 of the Darien City Code be deleted and the text in [Appendix A](#) be inserted in its stead.

SECTION 2: This Ordinance and each of its terms shall be the effective legislative act of a home rule municipality without regard to whether such Ordinance should (a) contain terms contrary to the provisions of current or subsequent non-preemptive state law, or (h) legislate in a manner or regarding a matter not delegated to municipalities by state law.

SECTION 3: Effective Date. This Ordinance shall be in full force and effect from and after its passage and approval as provided by law.

ORDINANCE NO. _____

PASSED BY THE CITY COUNCIL OF THE CITY OF DARIEN, DUPAGE COUNTY, ILLINOIS, this 20th day of July, 2020.

AYES: _____

NAYS: _____

ABSENT: _____

APPROVED BY THE MAYOR OF THE CITY OF DARIEN, DUPAGE COUNTY, ILLINOIS, this 20th day of July, 2020.

JOSEPH A. MARCHESE, MAYOR

ATTEST:

JOANNE E. RAGONA, CITY CLERK

APPROVED AS TO FORM:

CITY ATTORNEY

Chapter 20 DRUG PARAPHERNALIA

8-20-1 DEFINITIONS

8-20-2 POSSESSION OF DRUG PARAPHERNALIA

8-20-3 PENALTY

8-20-1 DEFINITIONS

CANNABIS: Shall have the meaning ascribed to it in Chapter 7 of the "Cannabis Regulation", as if that definition were incorporated herein.

CONTROLLED SUBSTANCE: Shall have the meaning ascribed to it in section 102 of the "Illinois Controlled Substances Act²", as if that definition were incorporated herein.

DRUG PARAPHERNALIA: All equipment, products and materials of any kind which are peculiar to or adapted for use in planting, growing, harvesting, manufacturing, producing, processing, preparing, testing, analyzing, packaging, storing, concealing, injecting, ingesting, inhaling, or otherwise introducing into the human body cannabis or a controlled substance in violation of the Cannabis Control Act, the Illinois Controlled Substances Act, [Chapter 7](#) of this Title, or similar law or local ordinance.

Drug paraphernalia shall include, but not be limited to: water, ice, air-driven, or electric pipes; miniature cocaine spoons or vials; smoking or carburetion pipes, tubes, masks, or other devices; bongs; roach clips; or any item whose purpose, as announced or described by the possessor, or whose actual use as determined by the presence of a controlled substance on, in or near the item, is for use in violating the Cannabis Control Act, the Illinois Controlled Substances Act, [Chapter 7](#) of this Title, or similar law or local ordinance. (Ord. 0-26-98, 12-7-1998)

8-20-2 POSSESSION OF DRUG PARAPHERNALIA

No person under the age of 21 shall knowingly possess an item of drug paraphernalia with the intent to use it in ingesting, inhaling, or otherwise introducing cannabis into the human body, or in preparing cannabis for that use.

No person shall knowingly possess an item of drug paraphernalia with the intent to use it in ingesting, inhaling, or otherwise introducing a controlled substance into the human body, or in preparing a controlled substance for that use.

In determining use or intent under this Section, the trier of fact can take into consideration the general, usual, customary and historical use to which the item involved has been put, and/or the proximity of the cannabis or controlled substance to the drug paraphernalia or the presence of cannabis or controlled substance on the drug paraphernalia. (Ord. 0-26-98, 12-7-1998)

8-20-3 PENALTY

Any person found guilty by a court of competent jurisdiction of having violated Section [8-20-2](#) of this Chapter shall be fined not less than one hundred dollars (\$100.00) nor more than five hundred dollars (\$500.00). (Ord. 0-26-98, 12-7-1998)

Footnotes - Click any footnote link to go back to its reference.

[Footnote 1](#): 720 ILCS 550/3.

AGENDA MEMO
City Council
July 20, 2020

ISSUE STATEMENT

An ordinance amending various sections of Title 8, “Police Regulations,” Chapter 7 “Cannabis Regulations” of the City of Darien city code.

ORDINANCE

BACKGROUND HISTORY

Staff is recommending several changes to Chapter 7, “Cannabis Regulations” ordinance. A change to the State law regarding recreational marijuana came into law 01/01/2020 which requires updating to the City of Darien’s ordinances.

STAFF/COMMITTEE RECOMMENDATION

Committee recommends approval of an ordinance updating the sale, purchase and possession of tobacco products to minors.

ALTERNATE CONSIDERATION

As directed.

DECISION MODE

This item will be on the July 20, 2020, City Council agenda for formal approval.

ON-PREMISES CONSUMPTION

A unit of local government, including a home rule unit, or any non-home rule county within the unincorporated territory of the county may regulate the on-premises consumption of cannabis at or in a cannabis business establishment within its jurisdiction in a manner consistent with the CRTA. The CRTA applies the restrictions of the Smoke Free Illinois Act on smoking cannabis and provides that property owners may prohibit the use of cannabis by any guest, lessee, customer or visitor.

DISPENSARIES

The CRTA pertains to the possession, use, cultivation, transportation, and dispensing of adult-use cannabis. The City of Darien has the authority to adopt ordinances and to promulgate rules and regulations that protect the public health, safety, and welfare of its citizens.

The City of Darien will permit adult use recreational cannabis dispensaries consistent with zoning ordinances regulating adult use recreational cannabis business establishments, including rules adopted governing the time, place, manner, and number of cannabis business establishments, and minimum distance limitations between cannabis business establishments and locations the City deems sensitive through a special use process.

The appropriate zoning ordinances, rules, and definitions shall be promulgated in the City's Unified Development Ordinance (UDO) effective January 1, 2020, as amended from time-to-time.

8-7-2 VIOLATION

- A. It is unlawful for any person to manufacture, deliver, or possess any and all equipment, products, and materials of any kind which are peculiar to and marketed for use in planting, propagating, cultivating, growing, harvesting, manufacturing, compounding, converting, producing, processing, preparing, testing, analyzing, packaging, repackaging, storing, containing, concealing, injecting, ingesting, inhaling, or otherwise introducing in the human body any controlled substance, including any and all articles listed in the Illinois Drug Paraphernalia Control Act, 720 Illinois Compiled Statutes 600, as amended.
- B. It is unlawful for any person under the age of twenty-one (21), or not in compliance with the Illinois Cannabis Regulation and Tax Act, to knowingly possess any quantity of any substance containing cannabis, except that the effect of this chapter shall be limited for purposes of municipal prosecution to persons knowingly possessing less than thirty grams (30g) of cannabis flower; five hundred milligrams (500mg) of tetrahydrocannabinol (THC) contained in cannabis-infused product; or five grams (5g) of cannabis concentrates. Unless authorized under the Illinois Compassionate Use of Medical Cannabis Pilot Program Act or the Illinois Cannabis Regulation and Tax Act, it is unlawful for any person to possess cannabis plants; except that the effect of this chapter shall be limited for purposes of municipal prosecution to persons knowingly possessing five (5) or fewer cannabis plants.
- C. The City of Darien prohibits the on-premises consumption of cannabis at or in a cannabis business establishment within its jurisdiction in a manner consistent with the Act.

8-7-3 PENALTY

Any person violating this section shall be fined not less than two hundred fifty dollars (\$250.00) for the first offense and five hundred dollars (\$500.00) for a subsequent offense for possession.

CITY OF DARIEN

DU PAGE COUNTY, ILLINOIS

ORDINANCE NO. _____

**AN ORDINANCE REPLACING
TITLE 8, POLICE REGULATIONS,
CHAPTER 7 CANNABIS REGULATIONS
OF THE CITY OF DARIEN CITY CODE**

ADOPTED BY THE

MAYOR AND CITY COUNCIL

OF THE CITY OF DARIEN

THIS 20th DAY OF JULY, 2020

**Published in pamphlet form by authority
of the Mayor and City Council of the City
of Darien, DuPage County, Illinois, this
20th day of July 2020.**

ORDINANCE NO. _____

AN ORDINANCE REPLACING TITLE 8, CHAPTER 7, "CANNABIS REGULATIONS" OF THE CITY OF DARIEN CITY CODE

BE IT ORDAINED BY THE CITY COUNCIL OF THE CITY OF DARIEN, DUPAGE COUNTY, ILLINOIS, IN THE EXERCISE OF ITS HOME RULE POWERS, as follows:

WHEREAS, changes have been made to the Illinois Compiled Statutes relating to cannabis offenses; and

WHEREAS, a portion of Chapter 7 of Title 8 of the Darien City Code is no longer consistent with State statutes; and WHEREAS, a revision of the cannabis related violations in Chapter 7 of Title 8 of the Darien is now appropriate;

NOW, THEREFORE, BE IT ORDAINED BY THE CITY COUNCIL OF THE CITY OF DARIEN, DUPAGE COUNTY, ILLINOIS, IN THE EXERCISE OF ITS HOME RULE POWERS, as follows:

SECTION 1: That Chapter 7 of Title 8 of the Darien City Code be deleted and the text in [Appendix A](#) be inserted in its stead.

SECTION 2: This Ordinance and each of its terms shall be the effective legislative act of a home rule municipality without regard to whether such Ordinance should (a) contain terms contrary to the provisions of current or subsequent non-preemptive state law, or (h) legislate in a manner or regarding a matter not delegated to municipalities by state law.

SECTION 3: Effective Date. This Ordinance shall be in full force and effect from and after its passage and approval as provided by law.

ORDINANCE NO. _____

PASSED BY THE CITY COUNCIL OF THE CITY OF DARIEN, DUPAGE COUNTY, ILLINOIS, this 20th day of July, 2020.

AYES: _____

NAYS: _____

ABSENT: _____

APPROVED BY THE MAYOR OF THE CITY OF DARIEN, DUPAGE COUNTY, ILLINOIS, this 20th day of July, 2020.

JOSEPH A. MARCHESE, MAYOR

ATTEST:

JOANNE E. RAGONA, CITY CLERK

APPROVED AS TO FORM:

CITY ATTORNEY

Chapter 7 CANNABIS REGULATIONS

8-7-1 CONTROLLED SUBSTANCES AND CANNABIS DEFINED:

8-7-2 VIOLATION

8-7-3 PENALTY

8-7-1 CONTROLLED SUBSTANCES AND CANNABIS DEFINED:

ADULT-USE CANNABIS DISPENSARIES

A facility operated by an organization or business that is licensed by the Illinois Department of Financial and Professional Regulation to acquire cannabis from licensed cannabis business establishments for the purpose of selling or dispensing cannabis, cannabis-infused products, cannabis seeds, paraphernalia or related supplies to purchasers or to qualified registered medical cannabis patients and caregivers, per the Cannabis Regulation and Tax Act, (P.A.101-0027), as it may be amended from time-to-time, and regulations promulgated thereunder.

CANNABIS

Includes marijuana, hashish and other substances which are identified as including any parts of the plant *Cannabis sativa*, whether growing or not; the seeds thereof, the resin extracted from any part of such plant; and any compound, manufacture, salt, derivative, mixture or preparation of such plant, its seeds, or resin, including tetrahydrocannabinol (THC) and all other cannabinol derivatives, including its naturally occurring or synthetically produced ingredients, whether produced directly or indirectly by extraction, or independently by means of chemical synthesis or by a combination of extraction and chemical synthesis; but shall not include the mature stalks of such plant, fiber produced from such stalks, oil or cake made from the seeds of such plant, any other compound, manufacture, salt, derivative, mixture, or preparation of such mature stalks (except the resin extracted therefrom), fiber, oil or cake, or the sterilized seed of such plant which is incapable of germination.

CANNABIS REGULATION AND TAX ACT (CRTA)

The Cannabis Regulation and Tax Act (CRTA) legalizes and regulates the production, consumption, and sale of recreational cannabis in Illinois. The CRTA allows Illinois residents over the age of twenty-one (21) to possess and privately use recreational cannabis in limited quantities; however, use of cannabis in public places is prohibited.

CONTROLLED SUBSTANCE

A drug, substance, or immediate precursor in the schedules of Article II of the Illinois Controlled Substances Act, 720 Illinois Compiled Statutes 570/201 et seq., as amended.

CRAFT GROWER

A facility operated by an organization or business that is licensed by the Department of Agriculture to cultivate, dry, cure, and package cannabis and perform other necessary activities to make cannabis available for sale at a dispensing organization or use at a processing organization. Craft-grower operations are not allowed in the City of Darien.

ON-PREMISES CONSUMPTION

A unit of local government, including a home rule unit, or any non-home rule county within the unincorporated territory of the county may regulate the on-premises consumption of cannabis at or in a cannabis business establishment within its jurisdiction in a manner consistent with the CRTA. The CRTA applies the restrictions of the Smoke Free Illinois Act on smoking cannabis and provides that property owners may prohibit the use of cannabis by any guest, lessee, customer or visitor.

DISPENSARIES

The CRTA pertains to the possession, use, cultivation, transportation, and dispensing of adult-use cannabis. The City of Darien has the authority to adopt ordinances and to promulgate rules and regulations that protect the public health, safety, and welfare of its citizens.

The City of Darien will permit adult use recreational cannabis dispensaries consistent with zoning ordinances regulating adult use recreational cannabis business establishments, including rules adopted governing the time, place, manner, and number of cannabis business establishments, and minimum distance limitations between cannabis business establishments and locations the City deems sensitive through a special use process.

The appropriate zoning ordinances, rules, and definitions shall be promulgated in the City's Unified Development Ordinance (UDO) effective January 1, 2020, as amended from time-to-time.

8-7-2 VIOLATION

- A. It is unlawful for any person to manufacture, deliver, or possess any and all equipment, products, and materials of any kind which are peculiar to and marketed for use in planting, propagating, cultivating, growing, harvesting, manufacturing, compounding, converting, producing, processing, preparing, testing, analyzing, packaging, repackaging, storing, containing, concealing, injecting, ingesting, inhaling, or otherwise introducing in the human body any controlled substance, including any and all articles listed in the Illinois Drug Paraphernalia Control Act, 720 Illinois Compiled Statutes 600, as amended.
- B. It is unlawful for any person under the age of twenty-one (21), or not in compliance with the Illinois Cannabis Regulation and Tax Act, to knowingly possess any quantity of any substance containing cannabis, except that the effect of this chapter shall be limited for purposes of municipal prosecution to persons knowingly possessing less than thirty grams (30g) of cannabis flower; five hundred milligrams (500mg) of tetrahydrocannabinol (THC) contained in cannabis-infused product; or five grams (5g) of cannabis concentrates. Unless authorized under the Illinois Compassionate Use of Medical Cannabis Pilot Program Act or the Illinois Cannabis Regulation and Tax Act, it is unlawful for any person to possess cannabis plants; except that the effect of this chapter shall be limited for purposes of municipal prosecution to persons knowingly possessing five (5) or fewer cannabis plants.
- C. The City of Darien prohibits the on-premises consumption of cannabis at or in a cannabis business establishment within its jurisdiction in a manner consistent with the Act.

8-7-3 PENALTY

Any person violating this section shall be fined not less than two hundred fifty dollars (\$250.00) for the first offense and five hundred dollars (\$500.00) for a subsequent offense for possession.

AGENDA MEMO
City Council Meeting
July 20, 2020

ISSUE STATEMENT

Consideration of a motion to approve the Darien Chamber of Commerce *20th Annual Darien Dash*, a 10K/5K Run/1 Mile Walk, on August 23, 2020 beginning at 8:00 A.M.

Consideration of a motion to approve the use of the right half of the following streets for the *Darien Dash* which begins at the Darien Swim and Recreation club and proceed as follows:

The 5K and 10K Course:

Start on Ironwood Avenue at the Darien Swim and Recreation club and head north to 69th street. Turn east on to 69th Street to Richmond Avenue; Turn south on Richmond Avenue to 70th Street; Turn east on 70th Street to Bentley Avenue; Turn north on Bentley Avenue to 69th Street; Turn east on 69th Street to Clarendon Hills Road; Turn south on Clarendon Hills Road to 70th Street; Turn west on 70th Street to Bentley Avenue; Turn south on Bentley Avenue to Maple Lane; Turn east on Maple Lane to Clarendon Hills Road; Turn south on Clarendon Hills Road to 71st Street; Turn west 71st Street to Bentley Avenue; Turn north on Bentley Avenue to Maple Lane; Turn west onto Maple Lane to Richmond Avenue; Turn south on Richmond Avenue to 71st Street; Turn west on 71st Street to Beechnut Lane; Turn north on Beechnut Lane to Ironwood Avenue; Turn east on Ironwood Avenue to start/finish line.

1-Mile Course:

Start on Ironwood Avenue at the Darien Swim and Recreation club and head north to 69th street. Turn east on to 69th Street to Sierra Drive; Turn south on Sierra Drive to 71st Street; Turn West on 71st Street to Beechnut Lane; Turn north on Beechnut Lane to Ironwood Avenue; Turn west on Ironwood Avenue to Start/finish line.

BACKUP

BACKGROUND HISTORY

The City Council is requested to review a motion to approve temporary street closures and police service for the Darien Chamber of Commerce *Annual Darien Dash*, a 10K/5K Run on Sunday, August 23, 2020 beginning at 8:00 A.M. This motion also gives authorization to the Chief of Police to finalize details for the *20th Annual Darien Dash* with the Darien Chamber of Commerce.

STAFF/COMMITTEE RECOMMENDATION

Staff recommends approval of the request from the Darien Chamber of Commerce through the partial closure of certain streets to facilitate the safety and efficient operation of the *Annual Darien Dash*. The Chamber will also be required to communicate with affected residents along the Dash route.

ALTERNATE CONSIDERATION

Not approve the motion at this time.

DECISION MODE

This item will be on the June 15, 2020, City Council Agenda for formal consideration.

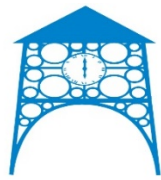

**Darien Chamber
of Commerce**
YOUR CONNECTION TO BUSINESS SUCCESS

July 10, 2020

Mayor Joseph Marchese
City of Darien
1702 Plainfield Road
Darien, IL 60561

Dear Mayor Marchese,

Due to the Covid19 health crisis, the original date for the 20th anniversary of Darien Dash was May 17, 2020 and was subsequently cancelled. I am requesting approval to hold the 1-Mile, 5k & 10k Race on a new date of Sunday, August 23, 2020 at 8:00am. **Please note that I have been in contact with our race timing company (J3) and informed that social distancing practices could be attained by having participants schedule their individual start times prior to the event.** In our ongoing effort to help support the Darien community, a portion of this event's proceeds will go to a Veterans organization associated with the Hinsdale South H.S. Hornets for Wounded Warriors group.

Attached please find a street map with course layout for the 1- Mile, 5k and 10k race. We request approval to use the right half of the involved streets for the Darien Dash:

1-Mile Course:

Start on Ironwood Avenue at the Darien Swim and Recreation club and head north to 69th street. Turn east on to 69th Street to Sierra Drive; Turn south on Sierra Drive to 71st Street; Turn West on 71st Street to Beechnut Lane; Turn north on Beechnut Lane to Ironwood Avenue; Turn west on Ironwood Avenue to Start/finish line.

The 5K and 10K Course:

Start on Ironwood Avenue at the Darien Swim and Recreation club and head north to 69th street. Turn east on to 69th Street to Richmond Avenue; Turn south on Richmond Avenue to 70th Street; Turn east on 70th Street to Bentley Avenue; Turn north on Bentley Avenue to 69th Street; Turn east on 69th Street to Clarendon Hills Road; Turn south on Clarendon Hills Road to 70th Street; Turn west on 70th Street to Bentley Avenue; Turn south on Bentley Avenue to Maple Lane; Turn east on Maple Lane to Clarendon Hills Road; Turn south on Clarendon Hills Road to 71st Street; Turn west 71st Street to Bentley Avenue; Turn north on Bentley Avenue to Maple Lane; Turn west onto Maple Lane to Richmond Avenue; Turn south on Richmond Avenue to 71st Street; Turn west on 71st Street to Beechnut Lane; Turn north on Beechnut Lane to Ironwood Avenue; Turn east on Ironwood Avenue to start/finish line.

In order to ensure the safety of the runners, we also request the Darien Police Department to redirect traffic away from the racecourse. Since the race is on a Sunday morning, we would not expect heavy traffic during the run. Thanking you in advance!

Sincerely,

April Padalik

Executive Director
Darien Chamber of Commerce

Attachment: (course map)

**Clarendon Hills Road
will be closed to traffic
between 69th and Rogers
from 8:00am until 10:30am**



Course Map
5Km = 1 Loop
10Km = 2 Loops



Darien Dash
5K & 10K Run
and 1-Mile Run/Walk

May 17th 2020

AGENDA MEMO
CITY COUNCIL
July 20, 2020

Case

PZC 2020-06 8131 Lemont Road (Solar Panel Screening Variation)

Ordinance

Issue Statement

Petitioner RETHINK Electric seeks approval to vary Section 5A-5-9-8(B)5 of the City Zoning Code for relief from the screening requirement for non-flush mounted solar panels at 8131 Lemont Road in Darien, Illinois.

General Information

Petitioner:	RETHINK Electric 850 North Central Avenue Wood Dale, IL 60191
Owner:	Safeguard Self Storage 3384 Peachtree Road, 4 th Floor Atlanta, GA 30326
Property Location / PIN#:	8131 Lemont Road / 09-32-106-034
Zoning / Land Use:	Site: OR&I / Self-storage facility North: OR&I / Office-warehouse and cell tower South: OR&I / Rockwell building and parking lot East: OR&I / Office-warehouse West: Woodridge (Zoned OR&I, currently single-family)
Comprehensive Plan:	Office/Research/Industrial
Size of Subject Lot:	117,437 square feet, 2.69 acres
Transportation:	Frontage to Lemont Road to both east (234') and north (430')

Zoning Provisions

Section 5A-5-9-8(B)5 / Solar Energy Systems, Building Mounted standards

Development History and Proposal

The Safeguard Self-Storage facility received approvals in 2002 and was constructed shortly thereafter. The building sits approximately 75 feet from the primary Lemont Road frontage, and 100 feet from the north road frontage. Several large deciduous trees help to screen the buildings height, which is 3 stories and approximately 40 feet. The building is unique in that there is no parapet wall at the cap of the building. Parapet walls typically extend higher than the roof, and are often constructed to screen various types of rooftop equipment.

The petitioner proposes to install a solar array in the flat roof of the building. Solar panels installed on a flat roof must be installed at an angle, and although not excessive in height, are approximately 14 inches off the roof at the highest point.

Section 5A-5-9-8(B)5 states “panels on a flat roof that are not flush-mounted must have a parapet or screening wall between the panels and the adjacent street and said parapet or screening wall must be at least as high as the panels.” Non-Flush mounted panels are further defined as any panels that extend more than 6 inches above the roof.

As presented, at 14 inches in height and without parapet wall on the building to properly screen the panels, the installation cannot occur without a variation. The petitioner has provided a response to the variation standards in a justification narrative which is attached.

The petitioner states that the unique condition of the property is the overall height of the building in comparison to surrounding development, and that the panels will not be seen in close proximity to the building. Line-of-sign diagrams have been provided for discussion.

Petitioner Documents (attached to this memo)

1. [Application](#), including variation justification
2. [Plat of Survey](#)
3. [Site Plans](#)
4. [Solar Racking Plans](#)
5. [Line of Sight Drawings](#)

Staff Documents (attached to this memo)

6. [Location Map](#)
7. [Zoning Variation Decision Criteria](#)

Staff Plan Review

The City’s solar code was revised in 2018 with the intention of removing obstructions to solar arrays when meeting certain conditions. Although the intent of the code was to prevent flat-roofed buildings, which are primarily commercial and office buildings, from installing visible solar panels and degrading the quality of a building’s architectural elevation, there were no exceptions written in the code when the impact would be unseen or minimal. Staff is supportive of the request based on the information as presented.

Findings of Fact

The Petitioner was asked to provide evidence or finding-of-fact that would support the requested variation, especially in terms of the pertinent variation criteria. Staff notes relevant criteria below:

- Unique Circumstances – This building was constructed in an industrial/office area with large setbacks and without a parapet screen wall.
- Character of the Locality – Although the roof has no parapet to screen the panels, the building’s height will eliminate or minimize any visual effect to the adjacent properties.
- Smallest Solution – Installation of a screen or parapet wall will require significant improvements to the roof structure.

PZC 6/17/2020

The Planning and Zoning Commission reviewed this petition at their public hearing on June 17. The petitioner presented the variation request and answered questions on overall visibility and impacts on the surroundings. No residents were in attendance regarding the petition. To address future precedent and the fact that the recently adopted code did not make exception to visibility, the motion for approval was specific to note that these solar panels could not be viewed from the street. The PZC made findings that the petition satisfied variation justifications and voted 7-0 to recommend approval of the request.

MSC – 7/20/2020

The Municipal Services Committee will discuss just prior to consideration by City Council and will forward a recommendation.

Decision Mode

The City Council will consider this this variation at its meeting on July 20, 2020.



ZONING APPLICATION

CITY OF DARIEN
1702 Plainfield Road, Darien, IL 60561
www.darienil.us 630-952-5000

CONTACT INFORMATION

Garrison Riegel
Applicant's Name
850 N. Central Ave. Wood Dale, IL 60191
Address, City, State, Zip Code
630-998-3629
Telephone
Garrison@rethinkelectric.com
Email

Robert Lebrier
Owner's Name
3384 Peachtree Rd 4th Floor, Atlanta GA 30326
Address, City, State, Zip Code
215-335-1927
Telephone
Rlabrier@safeguardit.com
Email

PROPERTY INFORMATION

Safeguard Storage - 8131 S. Lemont Rd. Darien, IL 60561 09-32-106-0345
Property address PIN Number(s)
Commercial, Property Class I Commercial Building, Storage Units
Zoning District Current Land Use(s)

(Attach additional information per the Submittal Checklist.)

REQUEST

Brief description of the zoning approval requested. (Contact the City Planner for guidance.)

We request a Variance from this statement: Panels on a flat roof that are not flush-mounted must have a parapet or screening wall between the panels and the adjacent street and said parapet or screening wall must be at least as high as the panels. We request a Variance because the proposed solar system will not be seen from the ground or neighboring buildings. This particular racking plus modules (collectors) only reaches a height of 13.5(in) from the surface of the roof at its highest point. The building's flat roof upon which we are installing is a 35(ft) 3 story building that has no parapets, yet it has existing equipment on the roof located on the west corner of the building, most notably a gas pipe and a curb mounted roof hatch that are the same height as our equipment. Neither can be seen from ground level. Additionally, the solar modules (collectors) are set back from the edge of the roof by at least 4 ft.

As Notary Public, in and for DuPage County in Illinois, I do hereby certify that Garrison Riegel is personally known by me to be the same person whose name is subscribed above and has appeared before me this day in person and acknowledged that they have signed this document as their own free and voluntary act, for the purposes therein set forth.

Given under my hand and seal, this 21st day of April 2020.

Dawn M. Heid
Notary Public

Table with 2 columns: Field and Value. Fields include Date Received (5/12/20), Case Number (PLC 2020-06), Fee Paid (485.00), and Hearing Date (6/17/20).

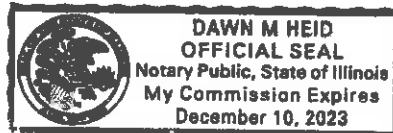

Justification Narrative: City of Darien

This justification narrative is in regards to the PV solar array being proposed on top of the Safeguard Storage building located at 3131 Lemont Rd. Darien, IL. We are requesting that we are permitted to construct this solar array without adding a parapet wall on the perimeter of the building as written in the City of Darien's code.

The variance is being requested due to there being no net visual benefit to adding this parapet wall to shield the array from being seen. As it currently exists, there are no vantage points that allow the system to be seen from around the building or from neighbors' buildings. There are currently roof hatches and other HVAC equipment on the roof that are of similar or greater height than our proposed solar array, and those cannot be seen from the surrounding areas.

Hardship condition would be an undo financial cost burden on the building owner. Adding a parapet wall is a costly endeavor and may involve modifying the structure of the building. This cost may effectively kill the project because the cost would be too great for the project to bear. In addition, the building is owned by a larger franchise entity which has a specific marketing brand/color scheme/aesthetic, and adding this parapet wall may disrupt that exterior brand.

As previously mentioned, there would be no impact on neighbors since it will not be possible to see the solar array from their vantage points. They will not know it is present.

2a. Not applicable

2b. We are currently installing numerous systems around numerous different cities and towns in Illinois and this is the only jurisdiction that is making such a request. Modifying the exterior of the building in this way is unnecessary, especially in this case where there will be no net benefit for anyone.

2c. The location of this building is in an industrial park, so adding a solar array to the roof without a parapet will not affect the essential character of the locality. The roof is 3 stories off the ground.

3a. As previously mentioned, if we were required to construct a parapet wall it may jeopardize the financial viability of installing solar at this store location.

3b. Not applicable

3c. There is no other simple and efficient way to install solar on this roof, although modifying our solar design would still not comply with the code the way it is presently written.

3d. Installing solar on top of this building will not cause any difficulty, hardship, burden or loss of value to neighboring buildings. Buildings are generously spaced, it is contained within an industrial park and the roof that the solar will be installed on is as high or higher than any other neighboring building.

3e. Future variances pertaining to solar array installations can be considered on a case by case basis based on the unique visual circumstances and the surrounding area where the building exists.

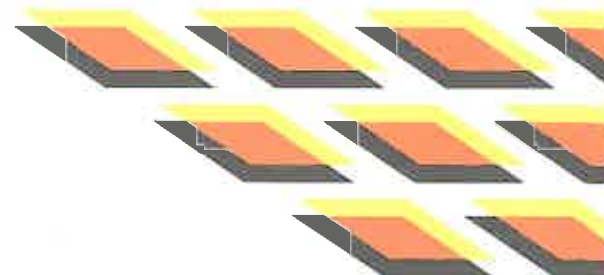

3f. The positive impact on making an exception to this code is to increase the adoption of clean, renewable and distributed energy in local communities such as Darien. If commercial solar projects are required to construct parapet walls on all buildings it will disincentivize building owners and solar installers from trying to build solar in your City.

3g. The only thing that this solar installation will do is increase the value of the building due to it having its own energy generation on site. The only other thing that could be considered is aesthetic, which does not apply here because it cannot be seen from any reasonable vantage point.

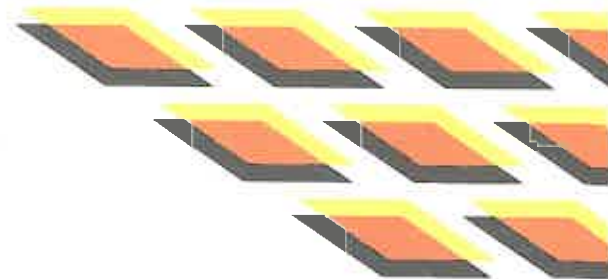

MEMO

ALTA/ACSM LAND TITLE SURVEY

SCALE: 1 INCH = 30 FEET
BEARINGS ARE ASSUMED

PARCEL 1: LOTS 6 AND 7 IN DARIEN CORPORATE CENTRE, BEING A SUBDIVISION OF PART OF THE NORTHWEST QUARTER OF SECTION 32, TOWNSHIP 38 NORTH, RANGE 11 EAST OF THE THIRD PRINCIPAL MERIDIAN, ACCORDING TO THE PLAT THEREOF RECORDED JUNE 29, 2000 AS DOCUMENT R2000-099131, IN DUPAGE COUNTY, ILLINOIS.

PARCEL 2: EASEMENT FOR BENEFIT OF PARCEL 1 AS CREATED BY THE PLAT OF DARIEN CORPORATE CENTRE, RECORDED JUNE 29, 2000 AS DOCUMENT R2000-099131, FOR INGRESS AND EGRESS OVER THE AREAS PLATTED AND DESIGNATED "INGRESS AND EGRESS EASEMENT"

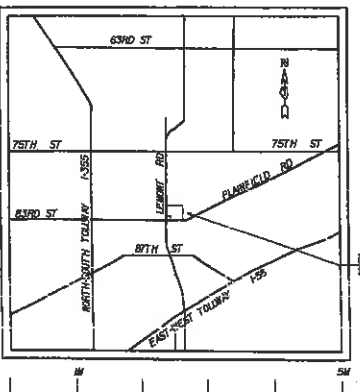

LOCATION MAP

LEGEND

SYMBOLS

- EXIST ADVERTISEMENT SIGN
- EXIST BORING LOCATION & LABEL
- EXIST BUSH
- EXIST CATCH BASIN
- EXIST UNDERGROUND CABLE
- EXIST CABLE TV SPLICE BOX
- EXIST CULVERT
- EXIST HANDHOLE
- EXIST ELECTRIC VAULT/TRANSFORMER
- EXIST LIFT STATION
- EXIST STREET LIGHT
- EXIST ELECTRIC SPLICE BOX
- EXIST STORM SEWER & SIZE
- EXIST SIGNAL CONTROLLER
- EXIST FENCE
- EXIST FIRE HYDRANT
- EXIST FLARED END SECTION
- EXIST FLAG POLE
- EXIST UNDERGROUND GAS LINE/SERVICE
- EXIST GAS VALVE
- EXIST GUYWIRE
- EXIST IBT SPLICE BOX
- EXIST IBT VAULT
- EXIST INLET
- EXIST IRON SURVEY MARKER
- EXIST LAND HOOK
- EXIST LIGHT FIXTURE
- EXIST WATERMAIN
- EXIST OVERHEAD ELECTRIC
- EXIST MAILBOX (PRIVATE)
- EXIST MANHOLE
- EXIST MONUMENT STONE/R.O.W. MARKER
- EXIST PIPE UNDERDRAIN/FIELD TILE
- EXIST POWER POLE
- EXIST SANITARY SEWER
- EXIST STREET SIGN
- EXIST TREE & SIZE (DECIDUOUS)
- EXIST EVERGREEN & SIZE
- EXIST TREE LINE/HEDGE
- EXIST UNDERGROUND ELECTRIC CABLE/DUCT/SERVICE
- EXIST UNDERGROUND IBT CABLE/DUCT
- EXIST VALVE & BOX
- EXIST VALVE & VAULT
- EXIST INLET
- NON BLANKET UTILITY EASEMENT
- BLANKET UTILITY EASEMENT
- UNDERGROUND CABLE
- PARKING SETBACK LINE

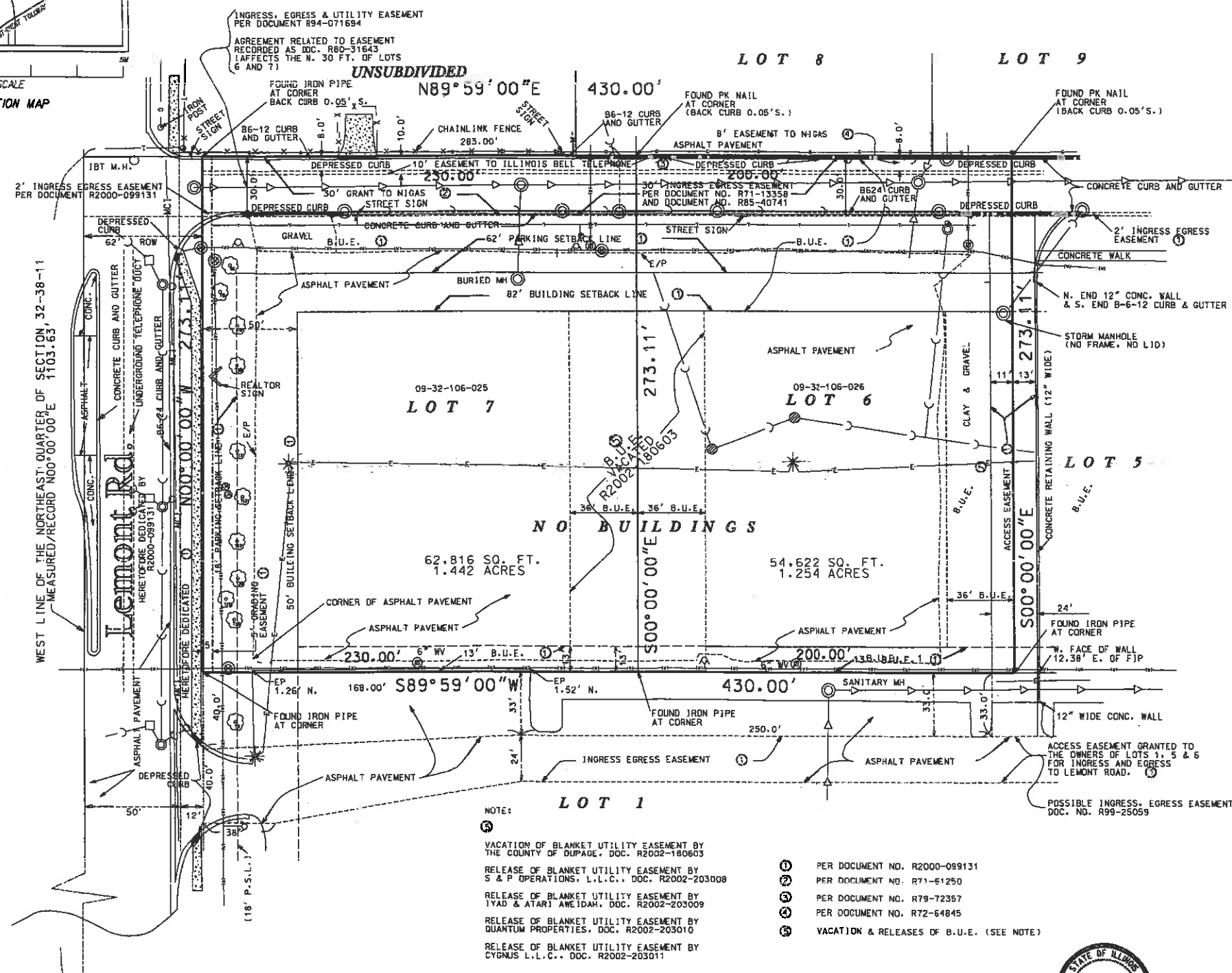

NOTE:

- ① VACATION OF BLANKET UTILITY EASEMENT BY THE COUNTY OF DUPAGE, DOC. R2002-180603
- ② RELEASE OF BLANKET UTILITY EASEMENT BY S & P OPERATIONS, L.L.C., DOC. R2002-203008
- ③ RELEASE OF BLANKET UTILITY EASEMENT BY IYAD & ATARI AMEIDAH, DOC. R2002-203009
- ④ RELEASE OF BLANKET UTILITY EASEMENT BY QUANTUM PROPERTIES, DOC. R2002-203010
- ⑤ RELEASE OF BLANKET UTILITY EASEMENT BY CYGNUS L.L.C., DOC. R2002-203011
- ⑥ PER DOCUMENT NO. R2000-099131
- ⑦ PER DOCUMENT NO. R71-61250
- ⑧ PER DOCUMENT NO. R79-72357
- ⑨ PER DOCUMENT NO. R72-64845
- ⑩ VACATION & RELEASES OF B.U.E. (SEE NOTE)

STATE OF ILLINOIS) S.S.
COUNTY OF KANE)

SURVEYOR'S CERTIFICATE

I, SAFAELMARD PROPERTIES, L.L.C., CHICAGO TITLE INSURANCE COMPANY, BANK ONE, N.A., ITS SUCCESSORS AND ASSIGNS

THIS IS TO CERTIFY THAT THIS MAP OR PLAT AND THE SURVEY ON WHICH IT IS BASED WERE MADE IN ACCORDANCE WITH "MINIMUM STANDARD DETAIL REQUIREMENTS FOR ALTA/ACSM LAND TITLE SURVEYS", DULY ESTABLISHED AND ADOPTED BY ALTA, NSPS AND NSPS IN 1998, AND INCLUDES ITEMS 1, 2, 3, 4, 6, 7(c), 7(d)(1), 8, 9, 10, 11(c), 13, 14, 15, AND 16 OF TABLE A THEREOF, PURSUANT TO THE ACCURACY STANDARDS AS ADOPTED BY ALTA, NSPS, AND NSPS, AND ACSM AND IN EFFECT ON THE DATE OF THIS CERTIFICATION.

THE UNDERSIGNED FURTHER CERTIFIES THAT PROPER FIELD PROCEDURES, INSTRUMENTATION AND ADEQUATE SURVEY PERSONNEL WERE EMPLOYED IN ORDER TO ACHIEVE RESULTS COMPARABLE TO THOSE OUTLINED IN THE "MINIMUM ANGLE, DISTANCE AND CLOSURE REQUIREMENTS FOR SURVEY MEASUREMENTS WHICH CONTROL LAND BOUNDARIES FOR ALTA/ACSM LAND AND TITLE SURVEYS".

THE UNDERSIGNED FURTHER CERTIFIES THAT NO PART OF THE SUBJECT PROPERTY IS LOCATED WITHIN AN AREA DESIGNATED AS A "SPECIAL FLOOD HAZARD AREA" BY THE FEDERAL EMERGENCY MANAGEMENT AGENCY (FEMA), FLOOD INSURANCE RATE MAP (FIRM), FOR THE COMMUNITY IN WHICH THE SUBJECT PROPERTY IS LOCATED.

BASED ON INSPECTION OF THE NATIONAL WETLANDS INVENTORY MAP (NWI) ISSUED BY THE U.S. FISH AND WILDLIFE SERVICE, THERE ARE NO WETLANDS LOCATED ON THE SUBJECT PROPERTY.

DATED THIS 12th DAY OF OCTOBER, 2002

Robert J. Dienhart P.S.

ROBERT J. DIENHART, ILLINOIS PROFESSIONAL LAND SURVEYOR, NO. 2840

ROBERT H. ANDERSON & ASSOCIATES, INC.
220 WEST RIVER DRIVE, ST. CHARLES, ILLINOIS 60174
(630) 584-3530 FAX (630) 584-3047



DARIEN CORPORATE CENTRE
ALTA/ACSM LAND TITLE SURVEY
CITY OF DARIEN, DUPAGE COUNTY, ILLINOIS

PROJECT NO.	569602-27
DATE	OCT. 11, 2002
SCALE	1" = 30'
CONTRACT NO.	569602-27
SHEET	1 OF 1

170106

PE OF WORK

GENERAL NOTES

TABLE OF CONTENTS

SYSTEM SIZE: 110960W DC, 100000W AC
 MODULES: (304) ADANI ASM-7-PERC-365
 INVERTER(S): (2) CHINT POWER SYSTEMS CPS SCA50KTL-DO/US-480
 RACKING: PANELCLAW POLAR BEAR HDIII - 56" ROW-TO-ROW SPACING
 ATTACHMENT: PANELCLAW BALLAST ATTACHMENT

WIND EXPOSURE: B
 WIND SPEED: 115mph
 GROUND SNOW LOAD: 25psf
 OCCUPANCY: PRIMARY COMMERCIAL
 CONSTRUCTION TYPE: COMMERCIAL

2014 NEC, 2015 IBC, 2015 IFC

BUILDING HEIGHT: 40 FEET
 PV SYSTEM SQUARE FOOTAGE: 6608.96 sqft

This approval is for compliance to the current adopted building codes for the proposed Solar System only. It is the owner's responsibility to ensure that the proposed installation of solar systems and associated equipment is on legally permitted structures. If determined by inspection staff the proposed solar system is installed on non-permitted structures, any required modifications needed for code compliance will be at the owner's expense

- LOCAL UTILITY PROVIDER SHALL BE NOTIFIED PRIOR TO USE AND ACTIVATION OF ANY SOLAR PHOTOVOLTAIC INSTALLATION
- THIS PROJECT SHALL COMPLY WITH LOCAL ORDINANCES
- PROPER ACCESS AND WORKING CLEARANCE WILL BE PROVIDED
- ALL ELECTRICAL WORK SHOWN ON THESE PLANS WILL BE COMPLETED BY THE UNDERSIGNED
- ALL APPLICABLE PV EQUIPMENT LISTED AND COMPLIANT WITH UL2703, UL1741 AND UL1703
- THE SYSTEM WILL NOT BE INTERCONNECTED UNTIL APPROVAL FROM THE LOCAL JURISDICTION AND THE UTILITY IS OBTAINED
- THE SOLAR PHOTOVOLTAIC INSTALLATION SHALL NOT OBSTRUCT ANY PLUMBING, MECHANICAL, OR BUILDING ROOF VENTS
- IF THE EXISTING MAIN PANEL DOES NOT HAVE VERIFIABLE GROUNDING ELECTRODE, IT IS NECESSARY TO INSTALL A SUPPLEMENTAL GROUNDING ELECTRODE
- EACH MODULE WILL BE GROUNDED PER UL 2703 OR UL 1703 APPROVED METHOD USING THE SUPPLIED CONNECTION POINTS IDENTIFIED ON THE MODULE AND THE MANUFACTURER'S INSTALLATION INSTRUCTIONS
- A LADDER SHALL BE IN PLACE FOR THE INSPECTION IN COMPLIANCE WITH OSHA REGULATIONS
- ALL WORK SHALL COMPLY WITH 2014 NEC, 2015 IBC, 2015 IFC MUNICIPAL CODE, AND ALL MANUFACTURERS' LISTINGS AND INSTALLATION INSTRUCTION.
- PHOTOVOLTAIC SYSTEM WILL COMPLY WITH 2014 NEC.
- PHOTOVOLTAIC SYSTEM INVERTER IS UNGROUNDED. NO CONDUCTORS ARE SOLIDLY GROUNDED IN THE INVERTER, AND SYSTEM COMPLIES WITH 690.35.
- MODULES CONFORM TO AND ARE LISTED UNDER UL 1703.
- INVERTER CONFORMS TO AND IS LISTED UNDER UL 1741.
- ELECTRICAL EQUIPMENT AND MATERIAL TO BE LISTED, LABELED, AND INSTALLED PER THE NEC, THE INSTALLATION STANDARDS/MANUFACTURER'S RECOMMENDATIONS AND IF REQUIRED A RECOGNIZED ELECTRICAL TESTING LABORATORY.
- CONDUITS EXPOSED TO SUNLIGHT ON ROOF SHALL BE LOCATED NOT LESS THAN 7/8" ABOVE ROOF SURFACE.

PAGE #	DESCRIPTION
PV 1.0	COVER SHEET
PV 2.0-2.1	SITE PLAN
PV 2.2	ROOF PLAN
PV 3.0	STRING DIAGRAM
PV 4.0-4.1	ELECTRICAL
PV 5.0	WARNING LABELS



CONTRACTOR
 RETHINK ELECTRIC
 POLINA KOSEVA
 850 N. CENTRAL AVE
 WOOD DALE, IL 60191
 Phone: (630) 621-8009
 Email: polina@rethinkelectric.com

DEVELOPER
 PIVOT ENERGY
 1536 WYNKOOP ST.,
 DENVER, CO 80202

PROJECT NAME & ADDRESS
SAFEGUARD STORAGE
 8131 LEMONT RD
 DARIEN, IL 60516

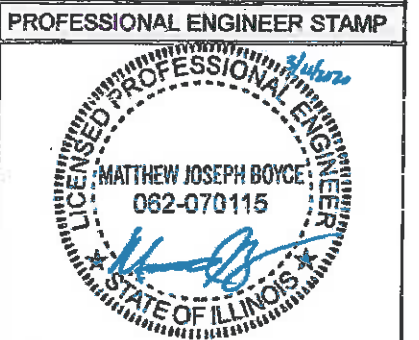

Rev A
 DATE: 10 March 2020

COVER SHEET
 PV 1.0

VICINITY MAP

VICINITY MAP

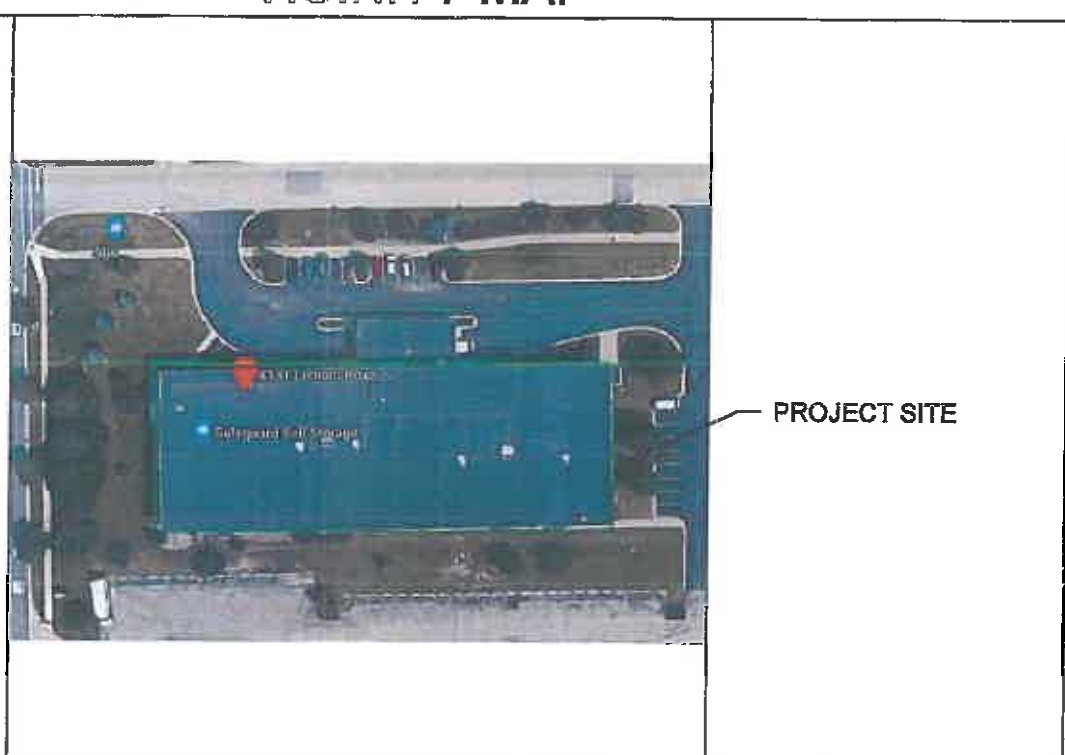

SITE PLAN: SCALE: 1" = 36'

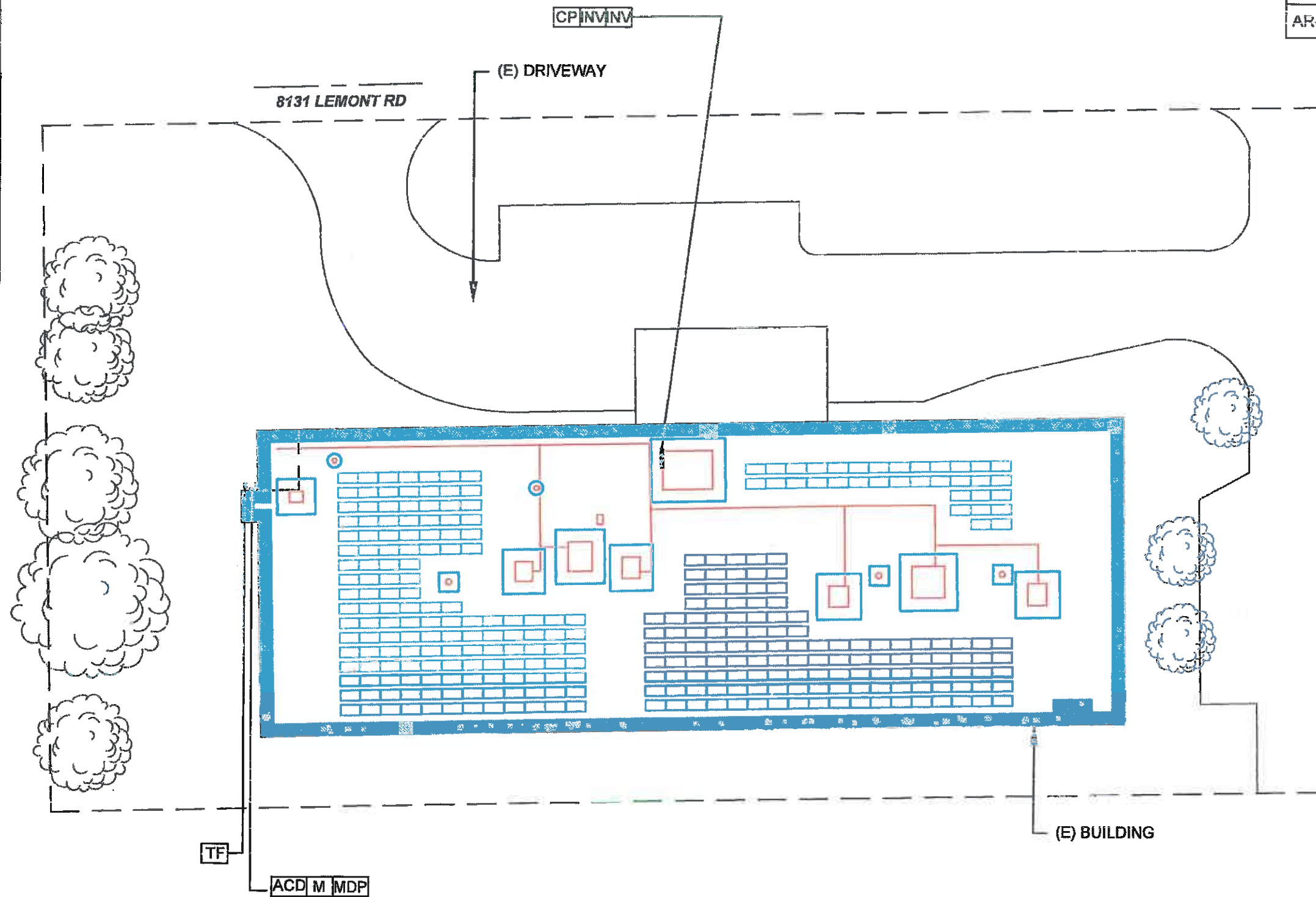

	ROOF SLOPE	AZIMUTH	SOLAR AREA (SQFT)	SOLAR WEIGHT (LBS)	# MODULES
AR-01	1°	179°	3130.56	7205.76	144
AR-02	1°	179°	739.16	1701.36	34
AR-03	1°	179°	2739.24	6305.04	126

LEGEND	
M	METER
MP	MAIN SERVICE PANEL
MDP	MAIN DISTRIBUTION PANEL
MSP	MAIN SERVICE PANEL
ACD	AC DISCONNECT
JB	JUNCTION BOX
INV	INVERTER
TF	TRANSFORMER
CP	COMBINER PANEL



CONTRACTOR
RETHINK ELECTRIC
 POLINA KOSEVA
 850 N. CENTRAL AVE
 WOOD DALE, IL 60191
 Phone: (630) 621-8009
 Email: polina@rethinkelectric.com

DEVELOPER
 PIVOT ENERGY
 1536 WYNKOOP ST.,
 DENVER, CO 80202

PROJECT NAME & ADDRESS
SAFEGUARD STORAGE
 8131 LEMONT RD
 DARIEN, IL 60516



Rev A
 DATE: 10 March 2020

SITE PLAN
PV 2.0

SITE PLAN DETAIL: SCALE:- 1" = 21.33333'



(N) 2 CHINT POWER SYSTEMS CPS SCA50KTL-DO/US-480
INVERTERS ON ROOF
(N) COMBINER PANEL ON ROOF

(E) HVAC

ARRAY-03

	ROOF SLOPE	AZIMUTH	SOLAR AREA (SQFT)	SOLAR WEIGHT (LBS)	# MODULES
AR-01	1°	179°	3130.56	7205.76	144
AR-02	1°	179°	739.16	1701.36	34
AR-03	1°	179°	2739.24	6305.04	126

(E) CONCRETE PAD MOUNTED TRANSFORMER

(N) 200A PV SYSTEM AC DISCONNECT

(E) UTILITY METER

(E) MAIN DISTRIBUTION PANEL, 800A
(INSIDE UTILITY ROOM)

(E) DRAIN, TYP

ARRAY-01

ELECTRICAL ROOM/ FIRE
PUMP ROOM

4' FIRE SETBACK,
TYP.

ARRAY-02

4'-0"

4'-0"

ROOF
ACCESS
POINT

4'-0"

4'-0"

(E) BUILDING

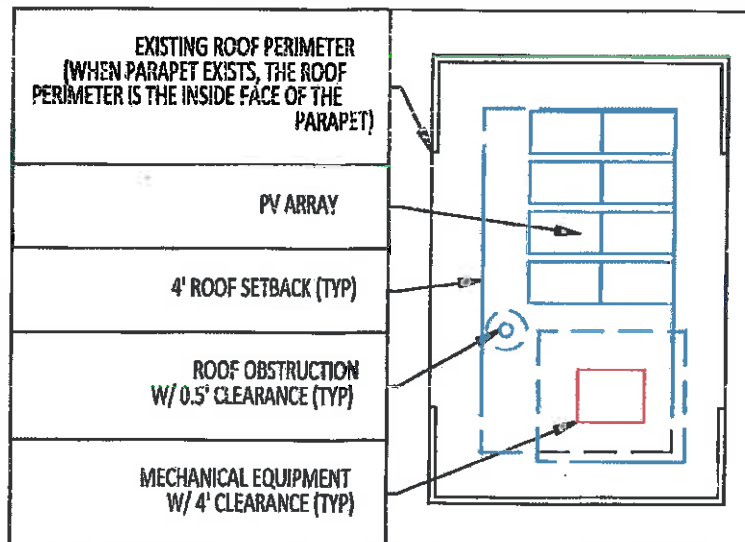

LEGEND	
[M]	METER
[MP]	MAIN SERVICE PANEL
[MDP]	MAIN DISTRIBUTION PANEL
[MSP]	MAIN SERVICE PANEL
[ACD]	AC DISCONNECT
[JB]	JUNCTION BOX
[INV]	INVERTER
[TF]	TRANSFORMER
[CP]	COMBINER PANEL



CONTRACTOR

RETHINK ELECTRIC
POLINA KOSEVA
850 N. CENTRAL AVE
WOOD DALE, IL 60191
Phone:(630) 621-8009
Email:polina@rethinkelectric.com

DEVELOPER

PIVOT ENERGY
1536 WYNKOOP ST.,
DENVER, CO 80202

PROJECT NAME & ADDRESS

SAFEGUARD STORAGE
8131 LEMONT RD
DARIEN, IL 60516

PROFESSIONAL ENGINEER STAMP



Rev A
DATE: 10 March 2020

SITE PLAN

PV 2.1

SITE PLAN DETAIL- SCALE:- 1" = 21.33334'

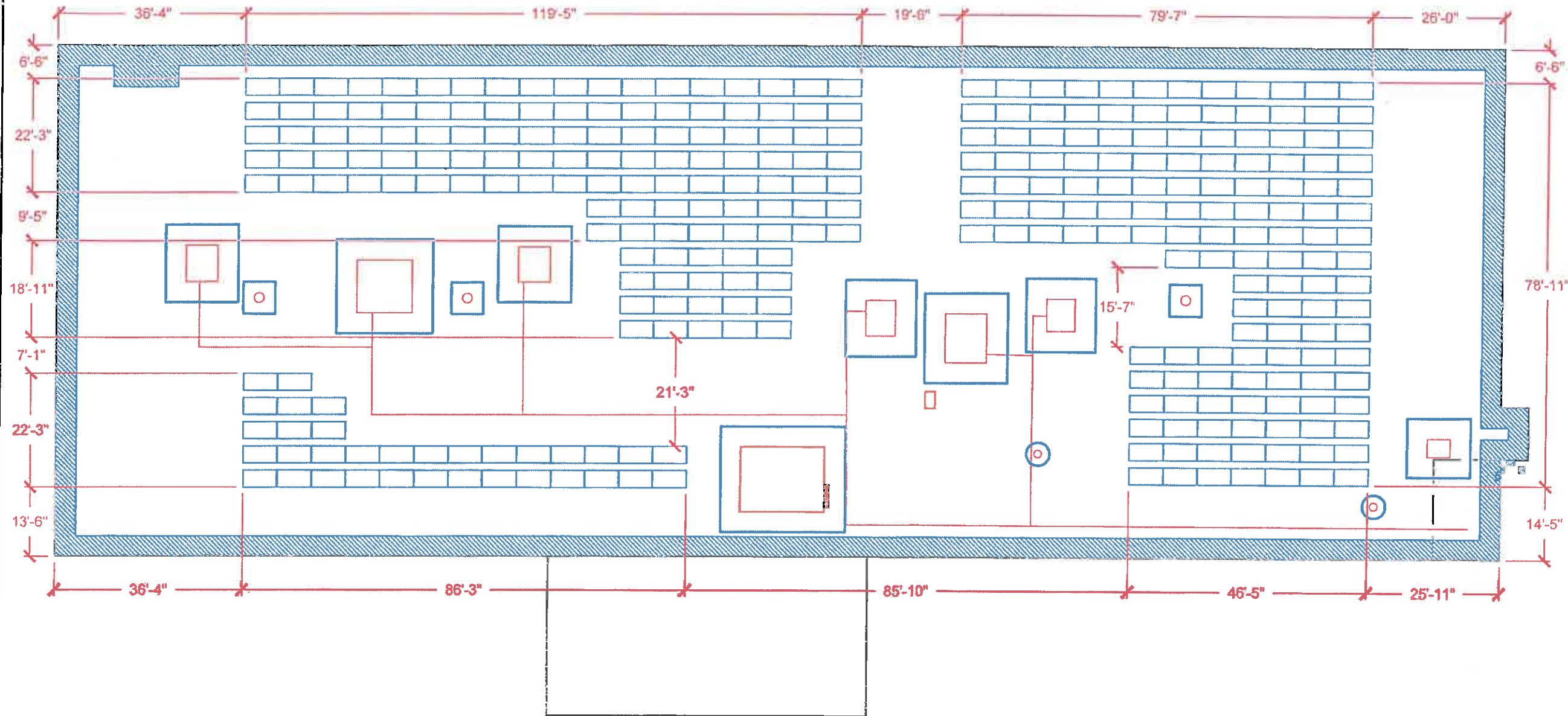

RETHINK
ELECTRIC

CONTRACTOR

RETHINK ELECTRIC
POLINA KOSEVA
850 N. CENTRAL AVE
WOOD DALE, IL 60191
Phone: (630) 621-8009
Email: polina@rethinkelectric.com

DEVELOPER

PIVOT ENERGY
1538 WYNKOOP ST.,
DENVER, CO 80202

PROJECT NAME & ADDRESS

SAFEGUARD STORAGE
8131 LEMONT RD
DARIEN, IL 60516

PROFESSIONAL ENGINEER STAMP



Rev A
DATE: 10 March 2020

ROOF PLAN

PV 2.2

SITE PLAN DETAIL: SCALE:- 3/64" = 1'-0"



LEGEND	
	STRING LENGTH: 18 MODULES NO. OF STRINGS: 15
	STRING LENGTH: 17 MODULES NO. OF STRINGS: 2

MPPT	STRING	STRING LENGTH
A (INV- 1)	1	18 MODULES
	2	18 MODULES
	3	18 MODULES
B (INV- 1)	4	18 MODULES
	5	18 MODULES
	6	18 MODULES
C (INV- 1)	7	18 MODULES
	8	18 MODULES
	9	18 MODULES

MPPT	STRING	STRING LENGTH
D (INV- 2)	10	18 MODULES
	11	18 MODULES
	12	18 MODULES
E (INV- 2)	13	18 MODULES
	14	18 MODULES
	15	18 MODULES
F (INV- 2)	16	17 MODULES
	17	17 MODULES

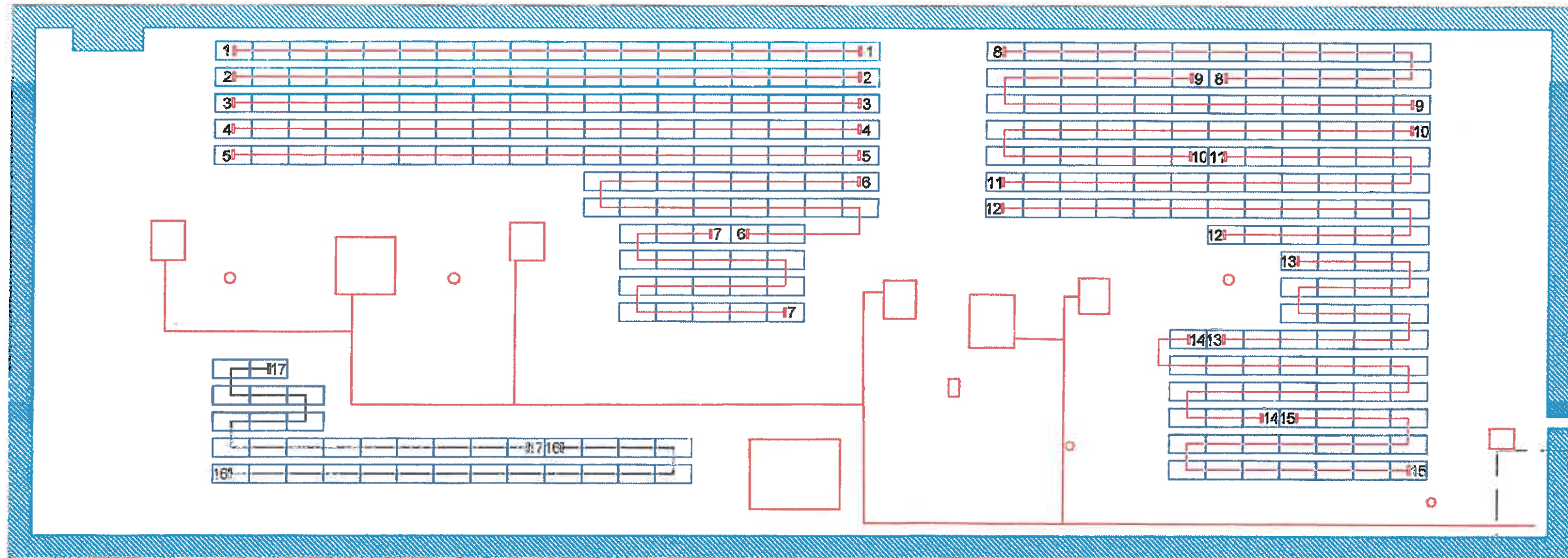

RETHINK
ELECTRIC

CONTRACTOR

RETHINK ELECTRIC
POLINA KOSEVA
850 N. CENTRAL AVE
WOOD DALE, IL 60191
Phone: (630) 621-8009
Email: polina@rethinkelectric.com

DEVELOPER

PIVOT ENERGY
1536 WYNKOOP ST.,
DENVER, CO 80202

PROJECT NAME & ADDRESS

SAFEGUARD STORAGE
8131 LEMONT RD
DARIEN, IL 60516

PROFESSIONAL ENGINEER STAMP

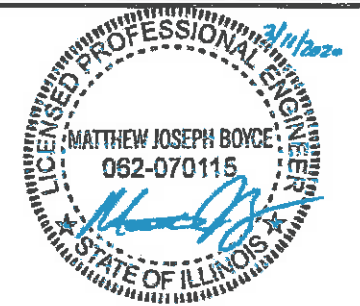

Rev A
DATE: 10 March 2020

STRING DIAGRAM

PV 3.0

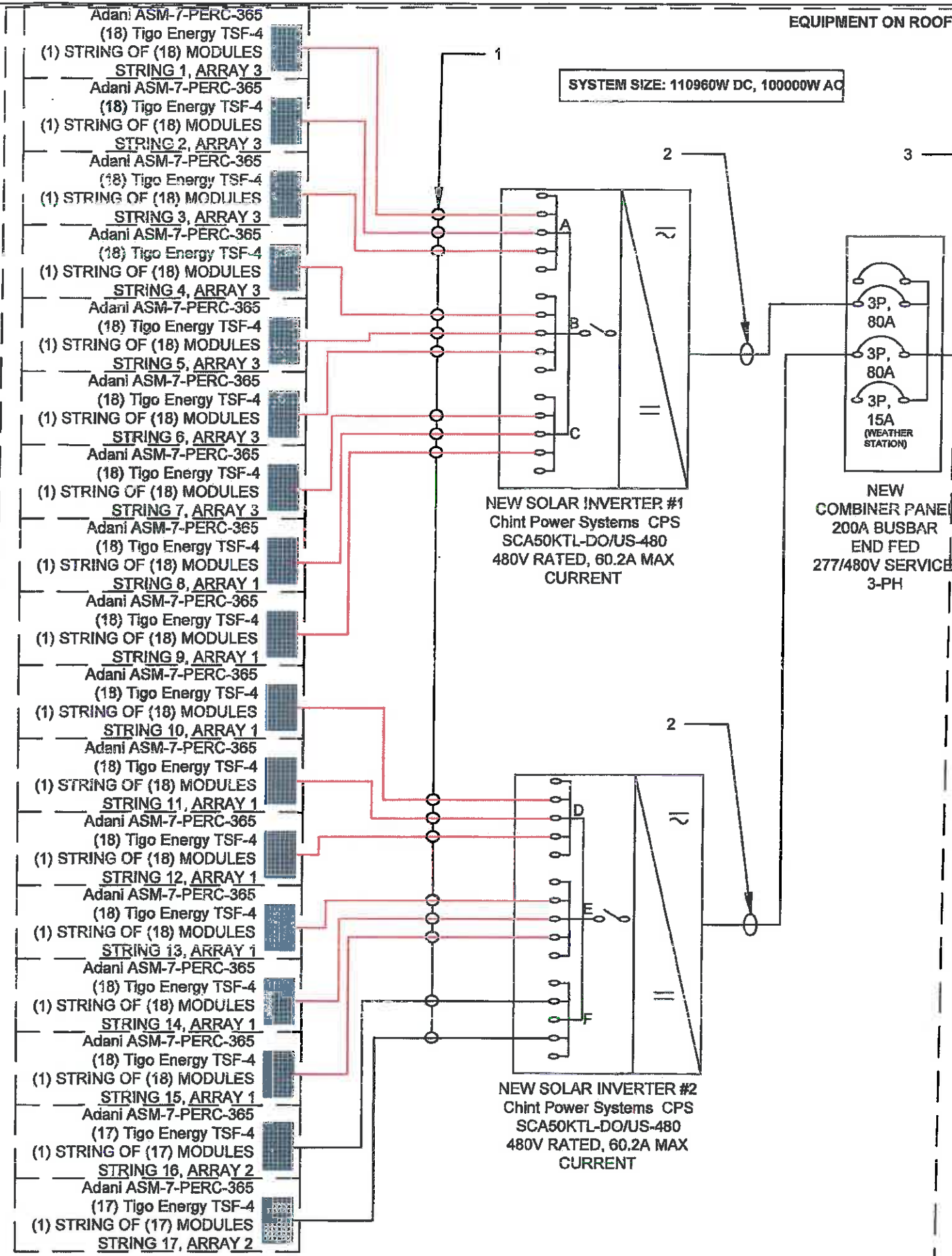

NOTE:
UTILIZING TIGO TSF-4 RAPID SHUT DOWN UNITS TO MEET NEC 690.12 REQUIREMENTS.

CONNECT SYSTEM VIA SUPPLY SIDE CONNECTION IN SPARE LUGS IN MAIN DISTRIBUTION PANEL ENCLOSURE. CONDUCTORS ARE FIELD INSTALLED.

#	CONDUIT	CONDUIT SCHEDULE				
		CONDUCTOR (RED/BLACK)	CONDUCTOR (BLUE)	NEUTRAL (WHITE)	GROUND	
1	NONE	(2) 10 AWG PV WIRE	NONE	NONE	(GREEN)	(1) 6 AWG (BARE COPPER)
2	1" EMT	(2) 4 AWG THHN/THWN-2	(1) 4 AWG THHN/THWN-2	(1) 8 AWG THHN/THWN-2	(1) 8 AWG THHN/THWN-2	NONE
3	2" EMT	(2) 3/0 AWG THHN/THWN-2	(1) 3/0 AWG THHN/THWN-2	(1) 8 AWG THHN/THWN-2	(1) 6 AWG THHN/THWN-2	NONE

LEGEND

— STRING LENGTH: 18 MODULES
NO. OF STRINGS: 15

— STRING LENGTH: 17 MODULES
NO. OF STRINGS: 2



CONTRACTOR
RETHINK ELECTRIC
POLINA KOSEVA
850 N. CENTRAL AVE
WOOD DALE, IL 60191
Phone: (630) 621-8009
Email: polina@rethinkelectric.com

DEVELOPER
PIVOT ENERGY
1536 WYNKOOP ST.,
DENVER, CO 80202

PROJECT NAME & ADDRESS
SAFEGUARD STORAGE
8131 LEMONT RD
DARIEN, IL 60516



Rev A
DATE: 10 March 2020

ELECTRICAL

PV 4.0

INVERTER RATINGS	
MAKE	CHINT POWER SYSTEMS
MODEL	CPS SCA50KTL-DO/US-480
MAX INPUT CURRENT	180A
MAX POWER (AC)	50000W
MAX DC INPUT VOLTAGE	1000V
RATED OUTPUT VOLTAGE	480V
MAX AC CURRENT	60.2A
CEC EFFICIENCY	98.5%

MODULE AND ARRAY RATINGS: (304) MODULES)				
SOLAR MODULE RATINGS (STC)			STRING 1-15	STRING 16 & 17
MAKE	ADANI	SERIES	18	17
MODEL	ASM-7-PERC-365	PARALLEL	1	1
I _{mp}	9.36A	I _{mp}	9.36A	9.36A
V _{mp}	39.01V	V _{mp}	702.18V	663.17V
I _{sc}	9.93A	I _{sc}	9.93A	9.93A
V _{oc}	47.31V	V _{oc}	851.58V	804.27V
P _{max}	365W	P _{max}	6570W	6205W
%V _{oc} /C	-0.29%	V _{oc} @ extreme min. temp	972.59V	918.56V

CONDUCTOR SIZING CALCULATIONS								
CIRCUIT DESCRIPTION	CURRENT	I _{max} (690.8(A))	I _{cont} (690.8(B)(2)(a) calc	SPECIFIED CONDUCTOR	AMPACITY @ 90c	AMBIENT TEMP c	CURRENT CARRYING COND.	COND. OF USE APPLIED (690.8(B)(2)(b) calc
INVERTER AC OUTPUT	60.2A	60.2A	60.20A I _{max} x 1.25 = 75.25A	#4 THWN-2	95A	31-35	1-3	95A x 0.96 (am b. temp.) x1 (raceway fill) = 91.2A
COMBINER PANEL OUTPUT	120.4A	120.4A	120.4A I _{max} x 1.25 = 150.25A	#3/0 THWN-2	225A	31-35	1-3	225A x 0.96 (am b. temp.) x1 (raceway fill) = 216A

TERMINAL TEMPERATURE RATING CONSIDERATIONS					
CIRCUIT DESCRIPTION	CURRENT	I _{cont}	TERMINAL TEMP RATING	SPECIFIED CONDUCTOR	AMPACITY @ TERMINAL TEMP. RATING
PV SOURCE CIRCUIT STRING 1-15	9.93A	12.41A x 1.25 = 15.52A	75C	#10	35A
PV SOURCE CIRCUIT STRING 16 & 17	9.93A	12.41A x 1.25 = 15.52A	75C	#10	35A
INVERTER AC OUTPUT	60.2A	60.20A I _{max} x 1.25 = 75.25A	75C	#4	85A
COMBINER PANEL OUTPUT	120.4A	120.4A I _{max} x 1.25 = 150.25A	75C	#3/0	200A

VOLTAGE DROP CALCULATIONS					
LENGTH	I	Ohms/kFt	V	CALC	V _{drop}
50Ft	9.93A	0.6282	1000V	50' x 9.93A x 2 x 0.6282/1000/1000V=	0.06%
50Ft	9.93A	0.9989	1000V	50' x 9.93A x 2 x 0.9989/1000/1000V=	0.10%
30Ft	60.2A	0.2485	480V	30' x 60.2A x 2 x 0.2485/1000/480V=	0.19%
30Ft	120.4A	0.0618	480V	30' x 120.4A x 2 x 0.0618/1000/480V=	0.09%



CONTRACTOR

RETHINK ELECTRIC
POLINA KOSEVA
850 N. CENTRAL AVE
WOOD DALE, IL 60191
Phone: (630) 621-8009
Email: polina@rethinkelectric.com

DEVELOPER

PIVOT ENERGY
1536 WYNKOOP ST.,
DENVER, CO 80202

PROJECT NAME & ADDRESS

SAFEGUARD STORAGE
8131 LEMONT RD
DARIEN, IL 60516

PROFESSIONAL ENGINEER STAMP



Rev A
DATE: 10 March 2020

ELECTRICAL

PV 4.1

INSTALL ON THE UTILITY METER

WARNING

THIS SERVICE METER IS ALSO SERVED BY A PHOTOVOLTAIC SYSTEM

INSTALL ON THE MAIN BREAKER PANEL

RAPID SHUTDOWN SWITCH FOR SOLAR PV SYSTEM

TO BE INSTALLED IN ACCORDANCE WITH SECTION 690.56(C):

CAUTION: SOLAR ELECTRIC SYSTEM CONNECTED

PHOTOVOLTAIC SYSTEM AC DISCONNECT

OPERATING VOLTAGE 480 VOLTS
OPERATING CURRENT 120.4 AMPS

WARNING

TURN OFF PHOTOVOLTAIC AC DISCONNECT PRIOR TO WORKING INSIDE PANEL

INSTALL ON PV ONLY SUBPANEL

NOTICE
PV SYSTEM COMBINER PANEL
DO NOT ADD LOADS TO THIS PANEL

LABEL LOCATION:
LOAD CENTER
[Only use when applicable for PV load center]

INSTALL ON THE AC DISCONNECT

PHOTOVOLTAIC SYSTEM AC DISCONNECT

OPERATING VOLTAGE 480 VOLTS
OPERATING CURRENT 120.4 AMPS

PV SYSTEM DISCONNECT FOR UTILITY OPERATION

WARNING

ELECTRIC SHOCK HAZARD

DO NOT TOUCH TERMINALS
TERMINALS ON BOTH THE LINE AND
LOAD SIDES MAY BE ENERGIZED
IN THE OPEN POSITION

**SOLAR PV SYSTEM
EQUIPPED WITH
RAPID SHUTDOWN**

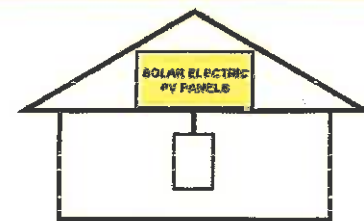

TURN RAPID SHUTDOWN SWITCH TO THE "OFF" POSITION TO SHUT DOWN PV SYSTEM AND REDUCE SHOCK HAZARD IN THE ARRAY.

INSTALL ON THE INVERTER#1

PHOTOVOLTAIC SYSTEM DC DISCONNECT

OPERATING VOLTAGE 972.59 VDC
OPERATING CURRENT 84.24 AMPS
MAX SYSTEM VOLTAGE 1000 VDC
SHORT CIRCUIT CURRENT 89.37AMPS
CHARGE CONTROLLER MAX N/A AMPS

INSTALL ON THE INVERTERS

WARNING

ELECTRIC SHOCK HAZARD

DO NOT TOUCH TERMINALS
TERMINALS ON BOTH THE LINE AND
LOAD SIDES MAY BE ENERGIZED
IN THE OPEN POSITION

WARNING

ELECTRIC SHOCK HAZARD

IF GROUND FAULT IS INDICATED,
ALL NORMALLY GROUNDED
CONDUCTORS MAY BE UNGROUNDED
AND ENERGIZED

TO BE INSTALLED EVERY 10 FEET ON ALL EXTERIOR CONDUIT, RACEWAYS AND BOXES

WARNING: PHOTOVOLTAIC POWER SOURCE

INSTALL ON THE INVERTER#2

PHOTOVOLTAIC SYSTEM DC DISCONNECT

OPERATING VOLTAGE 972.59 VDC
OPERATING CURRENT 74.88 AMPS
MAX SYSTEM VOLTAGE 1000 VDC
SHORT CIRCUIT CURRENT 79.44AMPS
CHARGE CONTROLLER MAX N/A AMPS



RETHINK ELECTRIC

CONTRACTOR

RETHINK ELECTRIC
POLINA KOSEVA
850 N. CENTRAL AVE
WOOD DALE, IL 60191
Phone: (630) 621-8009
Email: polina@rethinkelectric.com

DEVELOPER

PIVOT ENERGY
1536 WYNKOOP ST.,
DENVER, CO 80202

PROJECT NAME & ADDRESS

SAFEGUARD STORAGE
8131 LEMONT RD
DARIEN, IL 60516

PROFESSIONAL ENGINEER STAMP



Rev A
DATE: 10 March 2020

WARNING LABELS

PV 5.0

3/3/2020



Partner Name: ReThink Electric

Project Name: SG - Darien

**Project Location: 8131 Lemont Road
Darien, IL, 60516**

Racking System: Polar Bear III HD



Structural Calculations for Roof-Mounted Solar Array

Submittal Release: Rev 0

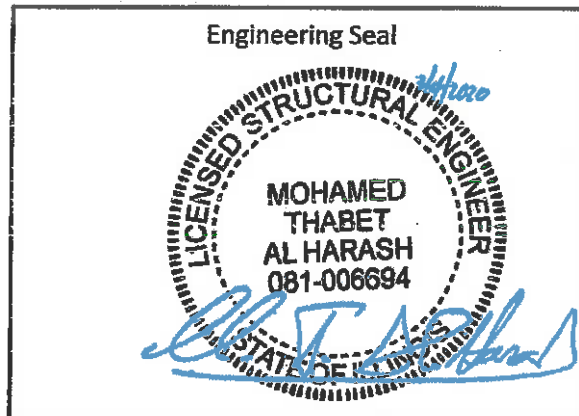

2.0 Snow Load:

Snow Calculations per ASCE 7-10, Chapter 7

2.1 Snow Load Data:

Ground Snow Load (Pg) =	25.00	psf	ASCE, Figure 7-1
Exposure Factor (Ce) =	1		ASCE, Table 7-2
Thermal Factor (Ct) =	1.2		ASCE, Table 7-3
Importance Factor (Is) =	1		(ASCE, Table 1.5-2)

Flat Roof Snow Load (Pf) =	$0.7 * P_g * C_e * C_t * I_s =$	<u>21.00</u>	psf	(ASCE 7.3-1)
Min Snow Load for Low Slope Roof =	$20 * I_s =$	<u>20.00</u>	psf	(ASCE 7.3.4)
Snow Load on Array (SLA) =	<u>21.00</u>	psf		

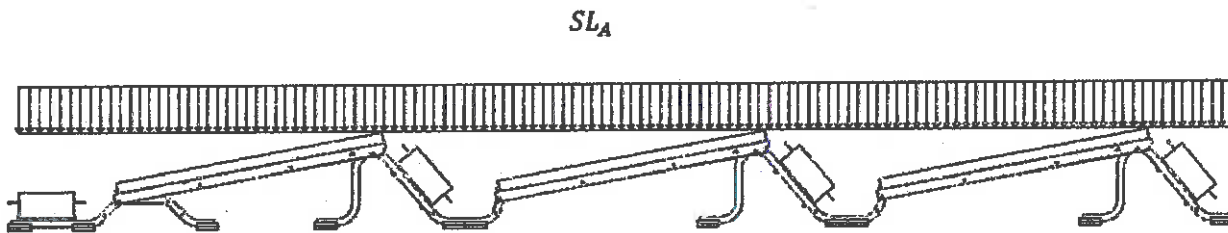

Fig. 2.1 - Uniform Roof Snow Load on Array

2.2 Snow Load Per Module:

Snow Load per Module (SLM) = $Module\ Projected\ Area * SL_A$

Where;

Module Projected Area (Amp) = $Module\ Area * Cos(Module\ Tilt)$

Where;

Module Area =	21.72	sq.ft.
Module Tilt =	10.40	degrees
Amp =	21.36	sq.ft.

$SL_M = A_{mp} * SL_A = \underline{448.65} \text{ lb}$



6.0 Design Loads - Downward:

6.1 Downward Wind Load Calculation:

$$WL_{in} = q_z * A_m * C_{fz} * \cos \theta$$

Where:

$q_z = 18.17$ psf

$A_m = 21.72$ sq.ft. (Single Module Area)

$\theta = 10.40$ deg.

$C_{fz} = 1.13$ (Inward)

$C_{fz} = 0.30$ (Inward with snow)

(Ref. Pg. 3, Wind Load)

(Ref. Pg. 1, Project Information)

(Ref. Pg. 1, Project Information)

(Proprietary Wind Tunnel Data)

(ASCE 7-10 figure 30.4-2A)

WL_{in} (no snow) = 439 lbs./module

WL_{in} (with snow) = 116 lbs./module

Contact Pad by Location:

A = Northern

B = Northern

C = Interior

D = Interior

E = Southern

F = Southern

6.2 Racking Dimensions for Point Loads:

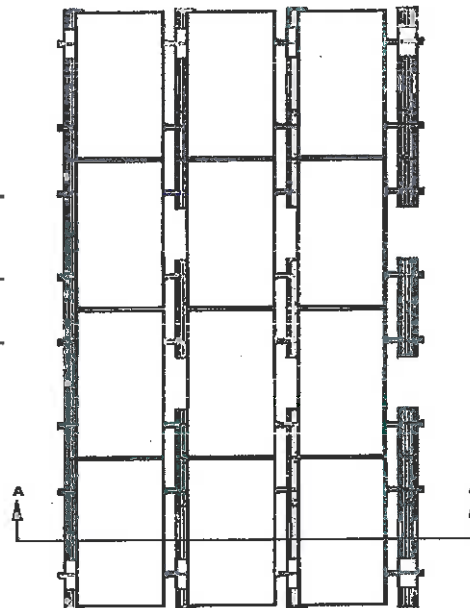
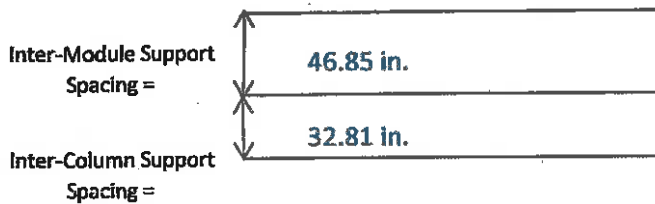

Typical Array Plan View
(Section A-A on Next Page)



6.0 Design Loads - Downward (CONT.):

6.2 Racking Dimensions for Point Loads (Cont.):

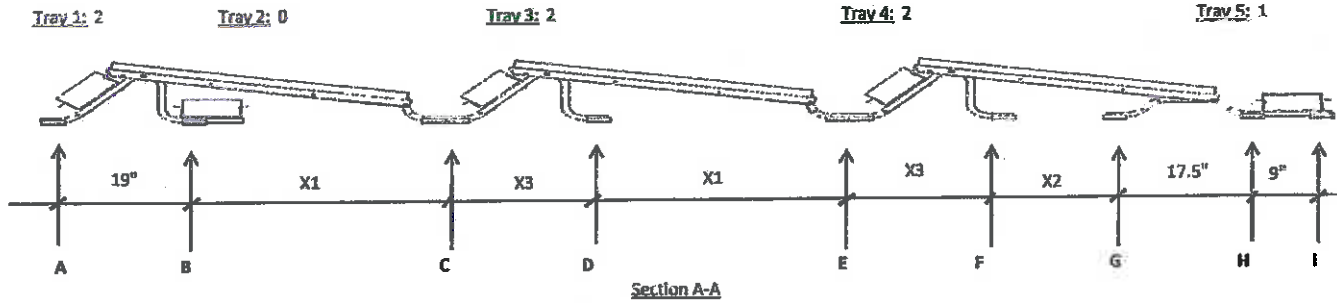

Distances Between Supports (Unless Noted):

- X1 = 34.25 in.
- X2 = 14.33 in.
- X3 = 21.77 in.

6.3 Point Load Summary:

- DL_{sys} = 72
- Total DL = (Varies on location and ballast quantity)
- SL_m = 449 lbs./module
- W_{in} (no snow) = 439 lbs./module
- W_{in} (with snow) = 116 lbs./module

Extreme Point Load Summary Table				
		load combinations (ASD)		
Location	Load	DL + S _{cm}	DL + 0.6 X W _{in}	DL + 0.75 X SL _m + 0.75(0.6 X W _{in})
Northern	A	86 lbs.	63 lbs.	79 lbs.
Northern	B	76 lbs.	53 lbs.	68 lbs.
Interior	C	152 lbs.	105 lbs.	137 lbs.
Interior	D	141 lbs.	94 lbs.	126 lbs.
Interior	E	152 lbs.	105 lbs.	137 lbs.
Interior	F	141 lbs.	94 lbs.	126 lbs.
Southern	G	43 lbs.	28 lbs.	38 lbs.
Southern	H	51 lbs.	36 lbs.	46 lbs.
Southern	I	51 lbs.	36 lbs.	46 lbs.
For Checking	J	893 lbs.	615 lbs.	804 lbs.

Table 6.1-A Extreme Point Load Summary

Ballast Block Point Load Summary - (LB/Single Block Applied at Tray Location)						
Location		Point Loads (lb/single block) at each Tray Location				
		Tray 1	Tray 2	Tray 3	Tray 4	Tray 5
Northern	A	11 lbs.				
Northern	B	5 lbs.	16 lbs.			
Interior	C			11 lbs.		
Interior	D			5 lbs.		
Interior	E				11 lbs.	
Interior	F				5 lbs.	
Southern	G					
Southern	H					8 lbs.
Southern	I					8 lbs.







Table 6.1-B Single Block Point Load Summary

ETERNAL SERIES

5BB Mono-Crystalline PERC Silicon Solar PV Modules - 1500V Series

ASM-7-PERC-AAA (AAA=365 - 390) | 72 Cells | 365 - 390 Wp

Highlights

-  Higher performance at longer wavelengths of light (1100-1200 nm)
-  Superior temperature co-efficient and performance at NOCT, PTC ratings
-  Excellent performance at low light irradiation (200 W/m²)
-  LIR treated cells with least LID effect
-  5 bus bar cells offering better reliability against microcracks
-  Triple EL checking to ensure defect free modules



Reduces installation costs by 3%

Reduces transport costs by 3%

Reduces land costs by 3%

Reduces BOS costs by 6%



Significant benefit of PERC technology

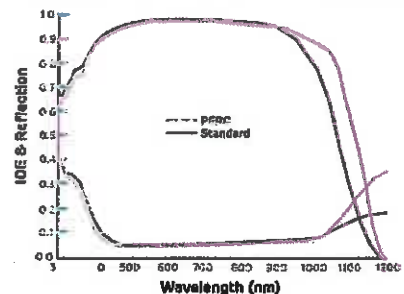

PERC technology enables better light capturing abilities at longer wavelength, weak and diffused light and in cloudy conditions.

Technical Data

Electrical data - All data measured to STC*

Peak power, (0 - + 4.99 Wp) Pmax (Wp)	365	370	375	380	385	390
Maximum voltage, Vmpp (V)	39.01	39.16	39.34	39.5	39.66	39.82
Maximum current, Imp (A)	9.36	9.46	9.55	9.64	9.743	9.84
Open circuit voltage, Voc (V)	47.31	47.47	47.67	47.77	47.99	48.16
Short circuit current, Isc (A)	9.93	9.99	10.03	10.06	10.11	10.16
Module efficiency (%)	18.09	18.34	18.58	18.9	19.1	19.35

Electrical parameters at NOCT

Maximum Power Pmax @ NOCT	275	279.2	283.4	287.6	291.72	295.88
Maximum voltage, Vmpp (V)	38.13	38.4	38.6	38.8	39.02	39.24
Maximum current, Imp (A)	7.21	7.28	7.35	7.41	7.48	7.55
Open circuit voltage, Voc (V)	46.87	47.09	47.31	47.53	47.77	48.00
Short circuit current, Isc (A)	7.61	7.68	7.75	7.82	7.87	7.94

*STC: Irradiance 1000 W/m², cell temperature 25°C, air mass AM1.5 according to EN 60904-3, Average efficiency reduction of 4.5% at 200 W/m² according to EN 60904-1. Except Pmp, all other parameters have a tolerance of +/-3%, measurement uncertainty <3%

*NOCT Irradiance 800 W/m², ambient temperature 20°C, wind speed 1 m/sec

Temperature co-efficients (TC) and permissible operating conditions

TC of open circuit voltage (β)	-0.29% / °C
TC of short circuit current (α)	0.048% / °C
TC of power (γ)	-0.39% / °C
Maximum system voltage	1500 V (IEC & UL)
NOCT	45°C ± 2°C
Temperature range	-40°C to + 85°C

Mechanical data

Length	1998 mm
Width	1010 mm
Height	35 mm/40 mm
Weight	22.7 Kg (35 mm) / 23 Kg (40mm)
Junction box	IP68
Cable and connectors	1200 mm length cable, MC4 & Amphenol compatible connectors
Application class	Class A (Safety class II)
Superstrate	High transmittance arc glass
Cells	72 mono-crystalline PERC solar cells; 5 bus bars
Encapsulation	Low shrinkage PID resistant EVA
Substrate	Tri layer backsheet
Frame	Anodized aluminium frame with twin wall profile
Mechanical load test as per IEC & UL	5400 Pa-front; 2400 Pa-back
Maximum series fuse rating	15 A

Dimensions in mm

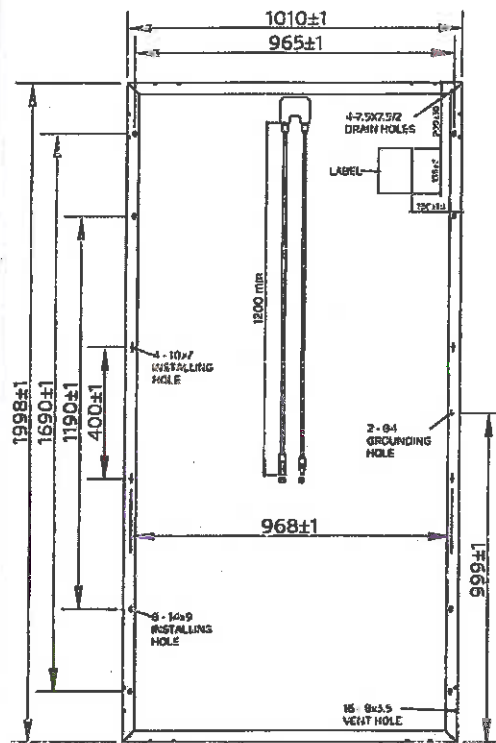

Current-Voltage Curve

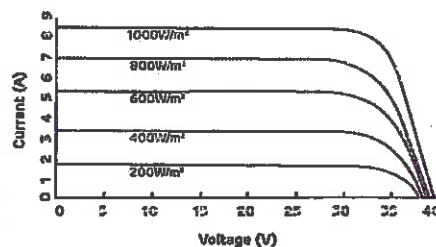

Warranty and certifications

Product warranty**
12 years of product warranty

Performance guarantee**
Power degradation <- 3% in first year
<- 0.68% / year in 2-25 years

Approvals and certificates: IEC 61215 Ed2, IEC 61730, IEC 61701, UL 1703, MCS, JET, CEC, CEC-Aus, IEC 62716, IEC 62759, IEC 62804, IEC 62782, IEC 60068-2-68, IEC 61853

**All certifications are under process

Note:

- The specifications included in this datasheet are subject to change without notice.
- The electrical data given here is for reference purpose only.
- Please confirm your exact requirements with the sales representative while placing your order. All models sold will be as per MSPVL QAP.

**Warranty:

Please read Adani solar warranty documents thoroughly.

*Caution: Please read safety and installation instructions before using the product.



Site Design Criteria - Flat Roof PV System Basis of Design	
Roof Live Load (psf) ¹	20 (see note 1)
Ground Snow Pg (psf)	25
Flat Roof Snow Pf (psf)	21
Snow Importance Factor (Is)	1.0
Wind Design Data	
Ult. Wind Speed (mph)	115
Nom. Wind Speed (mph)	N/A
Risk Category	II
Internal Pressure Coefficient	N/A
Design Life (years)	25 YEARS
MRI Adjustment Factor	0.93
Wind Exposure	B
C and C pressure (psf)	(see note 2)
Earthquake Design Data	
Risk Category	II
Importance Factor (Ie)	1.00
Component Importance Factor (Ip)	1.0
Mapped Acceleration Parameter (Ss)	0.155
Mapped Acceleration Parameter (S1)	0.066
Seismic Site Class	D - ASSUMED
Design Spectral Acceleration Parameter (Sds)	0.165
Design Spectral Acceleration Parameter (Sd1)	0.106
Seismic Design Category (SDC)	B
Basic seismic-force-resisting system(s)	see note 3
Base Design Shear = Fp x W	0.08 W
Seismic Response Coefficient (Cs)	N/A (see note 4)
Response Modification Factor (R)	2.5
Analysis Procedure	see note 3
Design Code (with local amendments)	2015 IBC
	ASCE 7-10
ADDITIONAL CODE PROVISIONS	
	SEAO PV1-2012
	SEAO PV2-2012
1. Roof Live Load only applicable to areas not covered by PV modules. Reference SEAO Design Guidelines	
2. PV wind design per proprietary wind tunnel testing. Refer to calculations for additional information	
3. Analysis procedure per ASCE 7 "Seismic Design Requirements for Nonstructural Components" and SEAO PV1-2012.	
4. Design values Fp which is calculated per procedure stated in note #3.	

GENERAL NOTES:

1. ALL SITE, PROJECT, AND BUILDING DETAILS ARE PROVIDED BY CUSTOMER OR GENERATED VIA SATELLITE IMAGERY FROM INFORMATION PROVIDED BY CUSTOMER. PANELCLAW IS NOT RESPONSIBLE FOR SITE INACCURACIES THAT COULD LEAD TO CHANGES TO THESE DRAWING DETAILS AND ARRAY LAYOUT CONFIGURATIONS. ALL INFORMATION CONTAINED WITHIN THESE DOCUMENTS ARE TO BE FIELD VERIFIED BY CUSTOMER AND INSTALLER. ANY CHANGES OR MODIFICATIONS TO THESE DOCUMENTS, CONTAINED INFORMATION, OR FINAL ARRAY AND MOUNTING SYSTEM INSTALLATIONS MUST BE SUBMITTED TO PANELCLAW AND OTHER PROJECT AUTHORITIES FOR APPROVAL.
2. REFER TO AND FOLLOW THE APPROPRIATE PANELCLAW INSTALLATION MANUALS AND PROCEDURES DURING THE INSTALLATION PROCESS. NOT FOLLOWING SUCH PROCEDURES AND METHODS COULD RESULT IN DAMAGE TO THE COMPONENTS OR MAY VOID THE PRODUCT WARRANTY.
3. ARRAY SETBACKS: ALL ARRAYS ARE REQUIRED TO BE SETBACK 4-FEET FROM ALL ROOF EDGES UNLESS OTHERWISE SPECIFIED AND CALLED OUT ON THE ARRAY DIAGRAMS ON THIS PAGE OR ON ADDITIONAL ARRAY BALLAST PAGES.
4. REFER TO THE SPECIFIC ARRAY BALLAST SHEETS FOR BALLASTING REQUIREMENTS BASED ON THE PROVIDED SITE INFORMATION.
5. SYSTEM PSF INCLUDES ALL PANELCLAW RACKING COMPONENTS, MECHANICAL ATTACHMENTS (IF APPLICABLE), PV MODULE AND BALLAST BLOCKS. FOR MAXIMUM SYSTEM POINT LOAD SUMMARY (PLS), REFER TO CALCULATIONS.
6. PANELCLAW AND/OR PANELCLAW CONSULTING ENGINEERS ARE NOT RESPONSIBLE FOR DETERMINING THE ADEQUACY OF THE STRUCTURE TO SUPPORT LOADS IMPOSED BY THE ARRAY AND MOUNTING SYSTEM. SUPPORT STRUCTURE TO BE CHECKED BY OTHERS.
7. ALWAYS ALLOW 6" CLEARANCE BETWEEN ARRAYS AND ALL FIXED ROOF OBJECTS OR ROOF EDGES. REFER TO LOCAL FIRE CODES AND ELECTRICAL CODES FOR ADDITIONAL REQUIREMENTS WHICH MAY GOVERN DESIGN.

DRIFTED SNOW LOAD POTENTIAL!

PANELCLAW HAS IDENTIFIED THIS PROJECT AS POTENTIALLY HAVING SIGNIFICANT ROOFTOP DRIFTED SNOW LOADS. PLEASE HAVE THE SE REVIEWING THE ROOF STRUCTURE FOR POTENTIAL SOLAR APPLICATIONS CONSIDER DRIFTED SNOW LOADS IN THEIR ANALYSES. IF DRIFTED SNOW LOADS ARE PRESENT WITHIN THE PROPOSED ARRAY FOOTPRINT(S), PROVIDE PANELCLAW A DRIFTED SNOW LOAD PLAN SO WE CAN AVOID THESE AREAS OR PLAN FOR ADDITIONAL LOADS ACCORDINGLY. IN GENERAL, DRIFTED SNOW LOADS CAN AFFECT MODULE SELECTION (I.E. MAX PSF) AND POINT LOADING FROM PANELCLAW RACKING TO THE ROOF STRUCTURE.

SHEET INDEX	
NO.	DESCRIPTION
PC-1	COVER SHEET
PC-2	ARRAY SITE MAP
PC-3	TYPICAL ARRAY DIMENSIONS
PC-4	RACKING COMPONENTS
PC-5	BALLAST LEGEND
PC-6	BALLAST LAYOUT - 1
PC-7	BALLAST LAYOUT - 2

STAMP:

PANELCLAW
 RACKING CONSTRUCTION SET
 1600 OSGOOD ST. SUITE 2023
 NORTH ANDOVER, MA 01845
 TEL: 978.688.4900
 www.panelclaw.com

© PANELCLAW, INC. ALL INFORMATION CONTAINED HEREIN IS THE PROPERTY OF PANELCLAW, INC. THE PURPOSE OF THIS DOCUMENT IS TO FACILITATE THE INSTALLATION OF PANELCLAW SOLAR PHOTOVOLTAIC MOUNTING SYSTEMS. DO NOT COPY OR REPRODUCE WITHOUT PERMISSION.

NO.	DATE	DESCRIPTION
0	2020-03-02	Initial Ballast Map Layout
	MM	CHECK
	BG	PREP
		REV

SCALE:

 ORIGINAL SIZE 36"x24"
 SHEET SIZE ARCH "D"

PREPARED FOR:
RETHINK ELECTRIC

PROJECT:
SG - DARIEN

LOCATION:
 8131 LEMONT ROAD
 DARIEN IL 60516

SHEET TITLE:
COVER SHEET

REVISION: 0	SHEET: PC-1
----------------	----------------

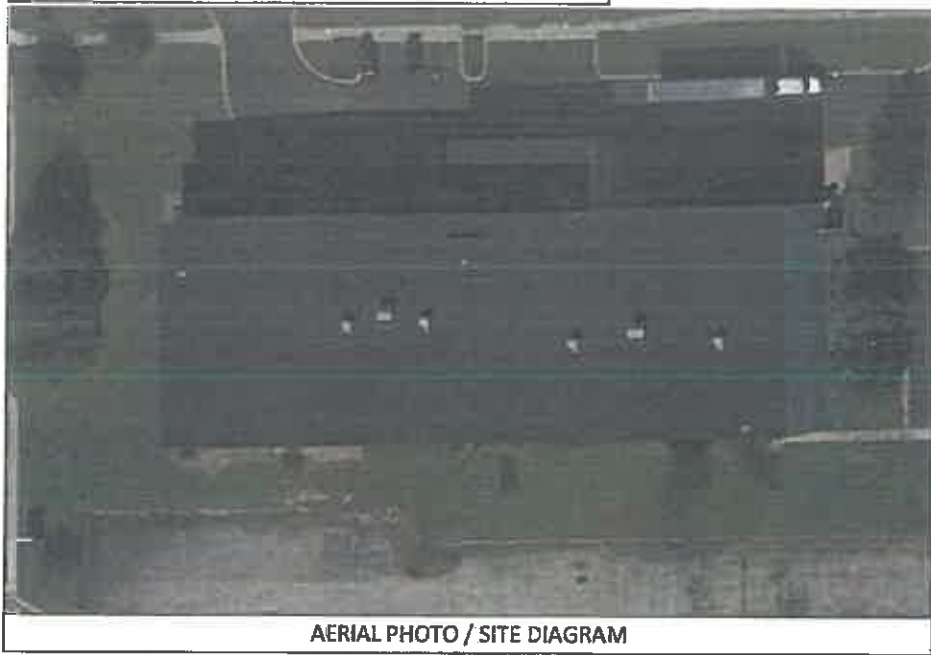

AERIAL PHOTO / SITE DIAGRAM

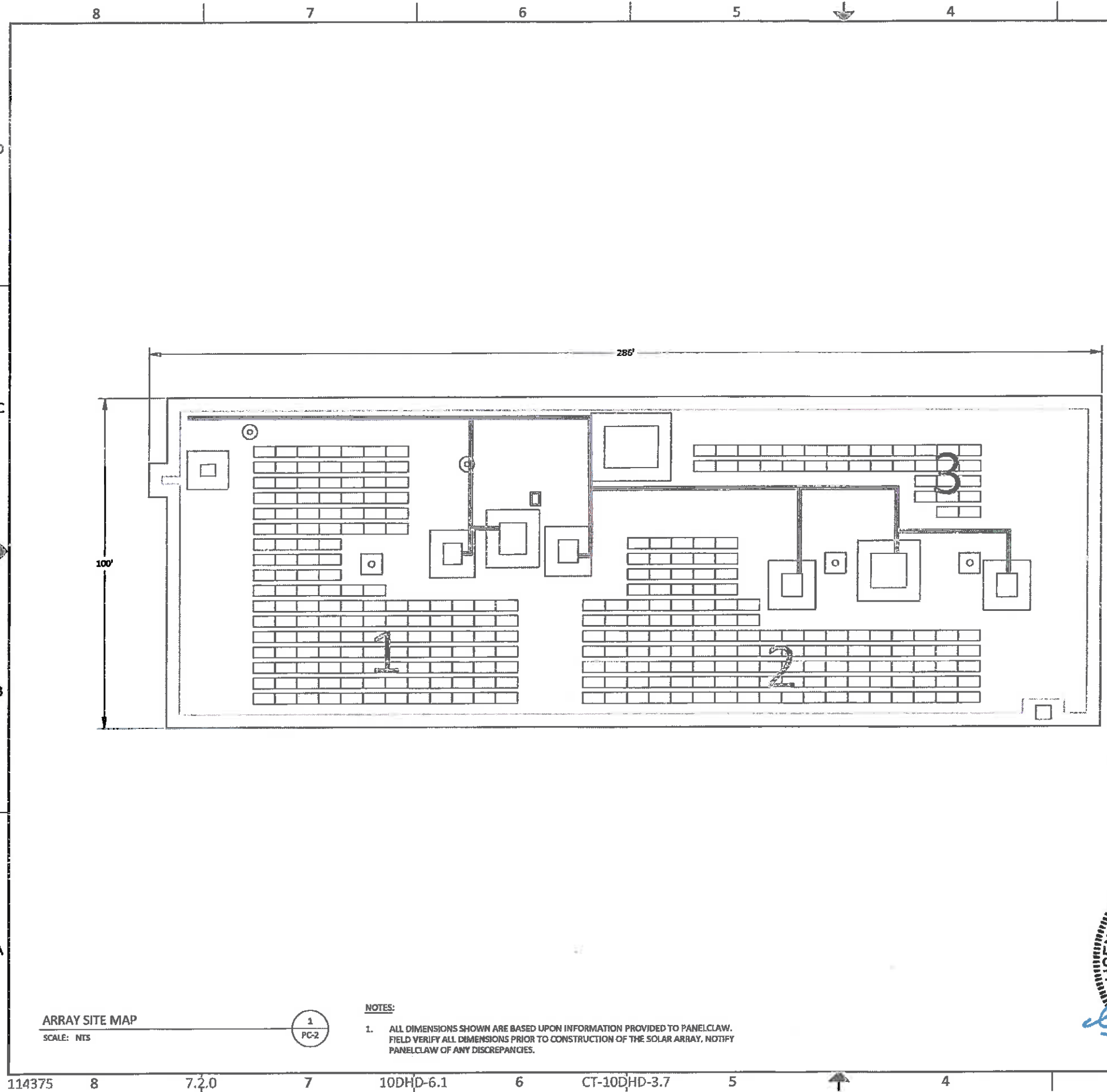

PROJECT SUMMARY	
MODULE TYPE	Admi Solar ASM-7-PERC-365
MODULE DIMENSIONS (IN.)	69.76 x 78.66 x 3.57
NUMBER OF MODULES	304
MODULE WATTAGE (W STC)	365
SYSTEM SIZE (KW STC)	111.0
SYSTEM HEIGHT (LR)	35/17
SYSTEM AREA (SQ. FT.)	9866
NUMBER OF ARRAYS	?
ARRAY TILT (DEG)	30.6

POLAR BEAR® III HD 30" - 56in PROJECT PART QUANTITY		
ITEM	PART NUMBER	QTY
NORTH SUPPORT	500041102	82
SOUTH SUPPORT		
STANDARD SUPPORT	500041001	816
LONG BALLAST TRAY		
SHORT BALLAST TRAY	200062503	76
CLAW		
HARDWARE - CLAW		
BOLT KIT - BALLAST TRAY		
NUT KIT - BALLAST TRAY		
CONCRETE MASONRY UNIT		

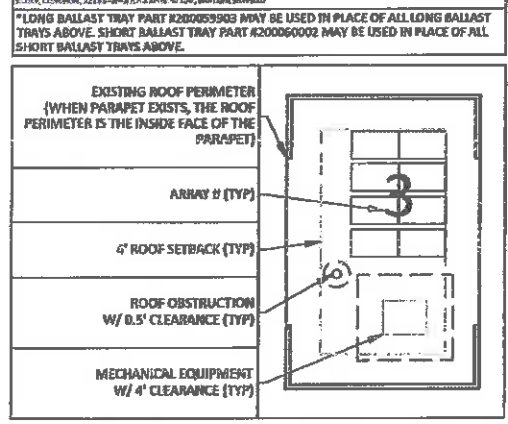

STAMP:

PANELCLAW®

RACKING CONSTRUCTION SET

1600 OSGOOD ST., SUITE 2023
NORTH ANDOVER, MA 01845
TEL: 978.688.4900
www.panelclaw.com

© PANELCLAW, INC.
ALL INFORMATION CONTAINED WITHIN THIS DOCUMENT IS PROPERTY OF PANELCLAW, INC. THE PURPOSE OF THIS DOCUMENT IS TO FACILITATE THE INSTALLATION OF PANELCLAW SOLAR PHOTOVOLTAIC MOUNTING SYSTEMS. DO NOT COPY OR REPRODUCE WITHOUT PERMISSION.

REV	DESCRIPTION	DATE
0	Initial Ballast Map Layout	2020-09-02
BG	PREP	
MM	CHECK	

SCALE:
0" 1/2" 1" 2"
ORIGINAL SIZE 36"x24"
SHEET SIZE ARCH "D"

PREPARED FOR:
RETHINK ELECTRIC

PROJECT:
SG - DARIEN

LOCATION:
**8131 LEMONT ROAD
DARIEN IL 60516**

SHEET TITLE:
ARRAY SITE MAP

REVISION: 0	SHEET: PC-2
-----------------------	-----------------------

MOHAMED THABET AL HARASH
081-006694
LICENSED STRUCTURAL ENGINEER
STATE OF ILLINOIS

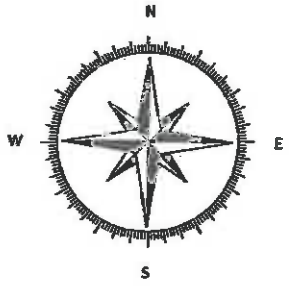

ARRAY SITE MAP
SCALE: NTS

NOTES:
1. ALL DIMENSIONS SHOWN ARE BASED UPON INFORMATION PROVIDED TO PANELCLAW. FIELD VERIFY ALL DIMENSIONS PRIOR TO CONSTRUCTION OF THE SOLAR ARRAY, NOTIFY PANELCLAW OF ANY DISCREPANCIES.

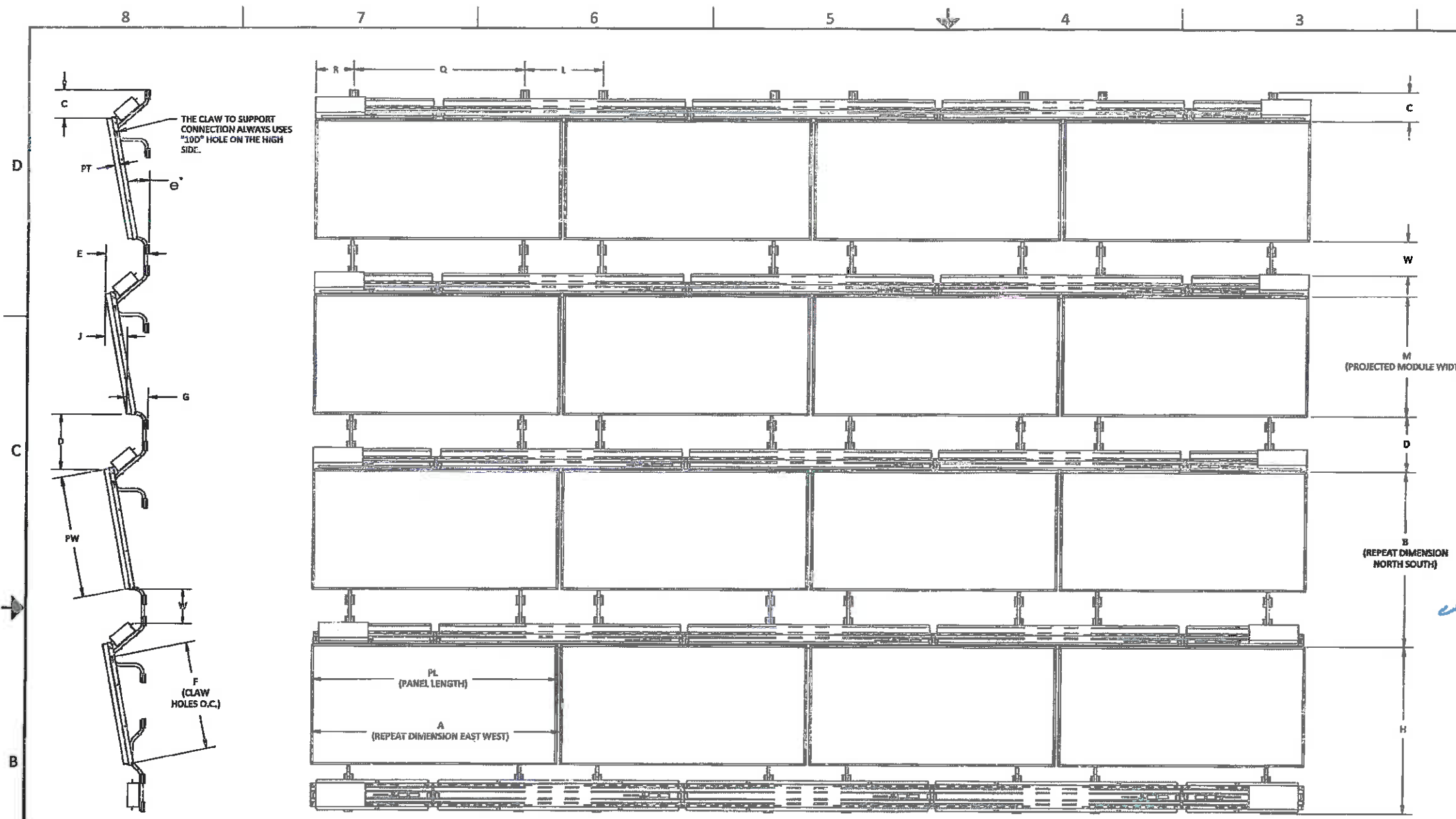

ARRAY CROSS SECTION VIEW
SCALE: NTS

ARRAY TOP VIEW
SCALE: NTS

WHEN INSTALLING CLAWS TO MODULES, BE SURE TO USE THE MODULE MOUNTING HOLES WITH THIS SPACING. SLIDE CLAWS TOWARD JUNCTION BOX PRIOR TO TORQUEING TO MAINTAIN CONSISTENT SUPPORT ALIGNMENT.

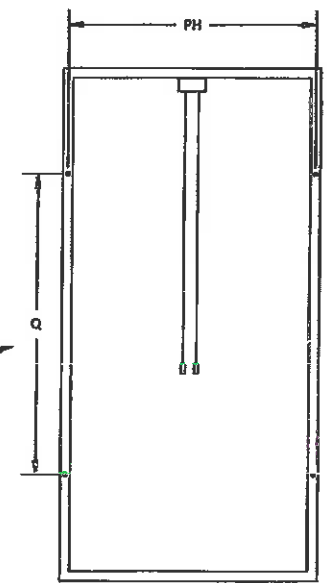
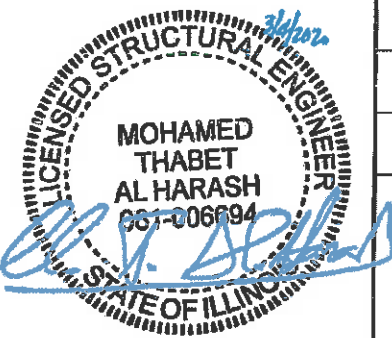

MODULE BACK VIEW DIMENSIONS
SCALE: NTS

		TYPICAL ARRAY DIMENSIONS																						
		PL	PWF	PT	PH	A	B	C	D	E	F	G	H	J	K	L	M	Q	R	W	Hole Diameter	θ (DEG)	D/J (#:1)	G.C.R.*
UNITS	mm	1998	1010	40	965	2023	1422	239	429	352	878	170	1356	182	103	893	993	1190	404	259	9.0	10.4	2.4	0.70
	IN	78.66	39.76	1.57	37.99	79.66	56.00	9.40	16.89	13.87	34.56	6.69	53.40	7.18	4.06	32.81	39.11	46.85	15.91	10.20	0.35	10.4	2.4	0.70

* G.C.R. - Ground coverage ratio calculation = (PL*M) / (A*B)

STAMP:

PANELCLAW®

RACKING CONSTRUCTION SET
1600 OSGOOD ST. SUITE 2023
NORTH ANDOVER, MA 01845
TEL: 978.688.4900
www.panelclaw.com

© PANELCLAW, INC. ALL INFORMATION CONTAINED HEREIN IS THE PROPERTY OF PANELCLAW, INC. THE PURPOSE OF THIS DOCUMENT IS TO FACILITATE THE INSTALLATION OF PANELCLAW SOLAR PHOTOVOLTAIC SYSTEMS. IT SHALL BE KEPT COPY ON DISSEMINATE WITHOUT PERMISSION.

REV	DESCRIPTION	PREP	CHECK	DATE
0	Initial Ballast Map Layout	BG	MM	2020-03-02

SCALE:
0" 1/2" 1" 2"
ORIGINAL SIZE 36"x24"
SHEET SIZE ARCH "D"

PREPARED FOR:
RETHINK ELECTRIC

PROJECT:
SG - DARIEN

LOCATION:
8131 LEMONT ROAD
DARIEN IL 60516

SHEET TITLE:
TYPICAL ARRAY DIMENSIONS

REVISION: 0 SHEET: PC-3

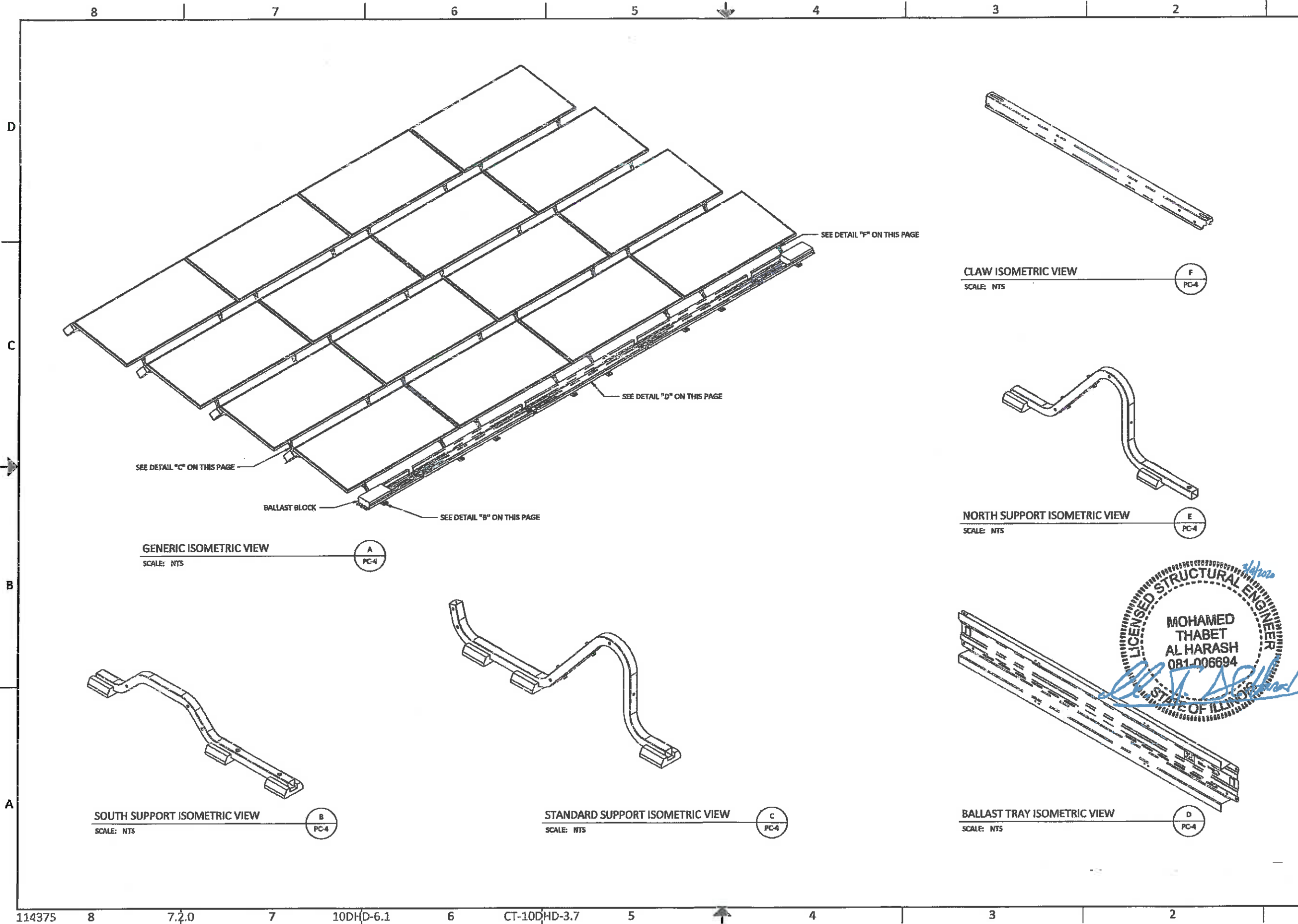

STAMP:

PANELCLAW®

RACKING CONSTRUCTION SET
1600 OSGOOD ST. SUITE 2025
NORTH ANDOVER, MA 01845
TEL: 978 688 4900
www.panelclaw.com

© PANELCLAW, INC.
ALL INFORMATION CONTAINED WITHIN THIS DOCUMENT IS PROPERTY OF PANELCLAW, INC.
THE PURPOSE OF THIS DOCUMENT IS TO FACILITATE THE INSTALLATION OF PANELCLAW SOLAR PHOTOVOLTAIC MOUNTING SYSTEMS. DO NOT REPLY OR ACKNOWLEDGE WITHOUT PERMISSION.

REV	DESCRIPTION	DATE
0	Initial Ballast Map Layout	2020-05-02
		MM
		DD
		YY

SCALE:
0" 1/2" 1" 2"
ORIGINAL SIZE 36"X24"
SHEET SIZE ARCH "D"

PREPARED FOR:
RETHINK ELECTRIC

PROJECT:
SG - DARIEN

LOCATION:
8131 LEMONT ROAD
DARIEN IL 60516

SHEET TITLE:
RACKING COMPONENTS

REVISION: 0 SHEET: PC-4

3/12/2020
LICENSED STRUCTURAL ENGINEER
MOHAMED THABET
AL HARASH
081-006694
STATE OF ILLINOIS

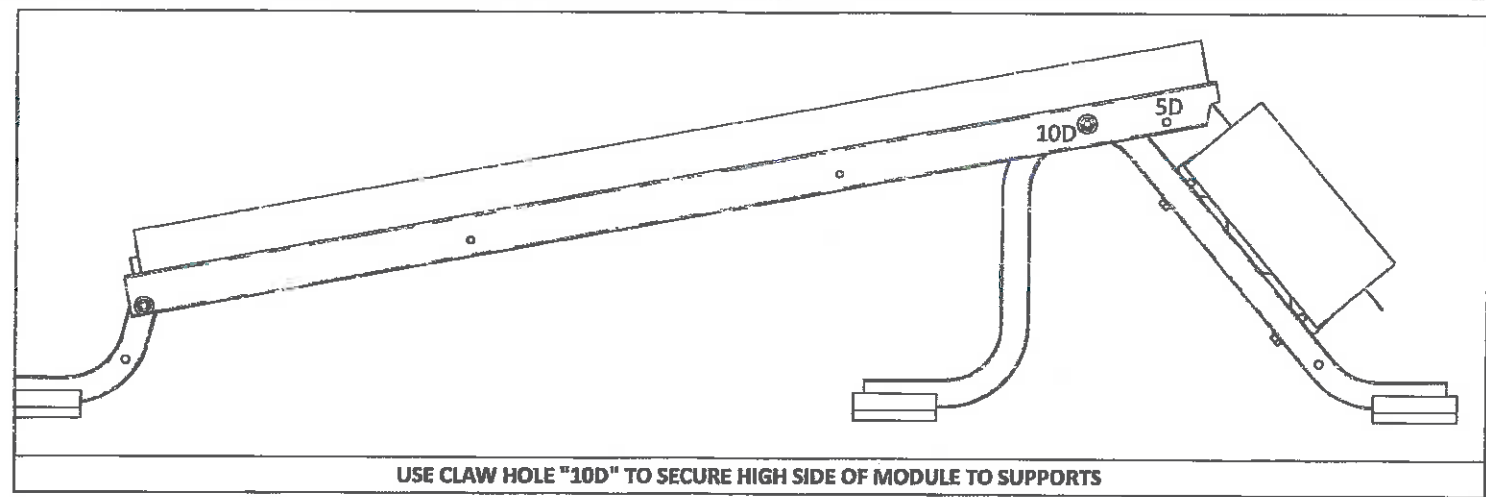
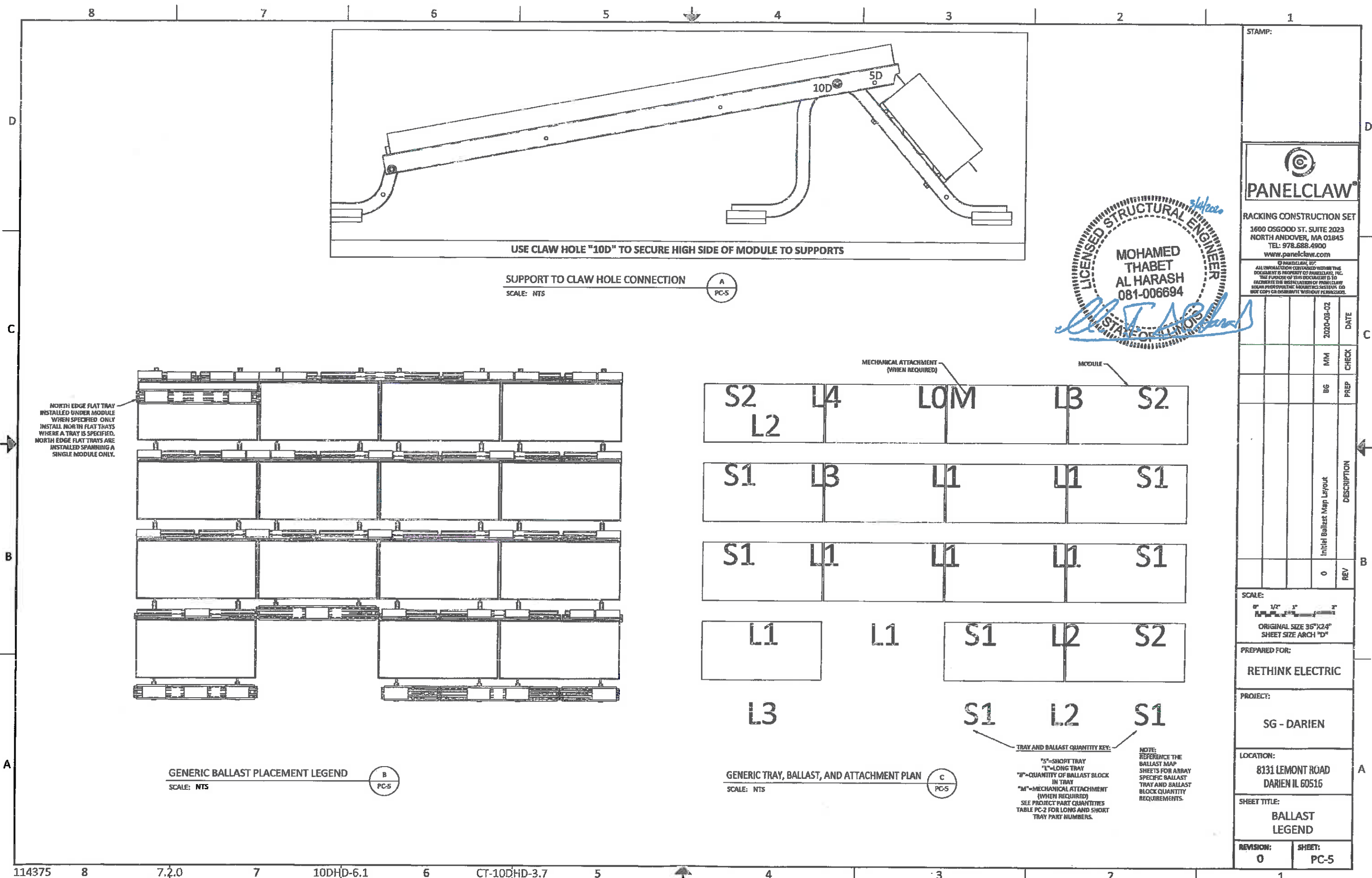

SUPPORT TO CLAW HOLE CONNECTION
SCALE: NTS

A
PC-5

LICENSED STRUCTURAL ENGINEER
MOHAMED THABET AL HARASH
081-006694
STATE OF ILLINOIS

STAMP:

PANELCLAW®
RACKING CONSTRUCTION SET
1600 OSGOOD ST. SUITE 2023
NORTH ANDOVER, MA 01845
TEL: 978.688.4900
www.panelclaw.com

© PANELCLAW, INC. ALL INFORMATION CONTAINED WITHIN THIS DOCUMENT IS PROPERTY OF PANELCLAW, INC. THE PURPOSE OF THIS DOCUMENT IS TO FACILITATE THE INSTALLATION OF PANELCLAW SOLAR PHOTOVOLTAIC MOUNTING SYSTEMS. DO NOT COPY OR TRANSMIT WITHOUT PERMISSION.

REV	DESCRIPTION	DATE
0	Initial Ballast Map Layout	2020-03-02

SCALE:
1" = 1/2"
ORIGINAL SIZE 36"X24"
SHEET SIZE ARCH "D"

PREPARED FOR:
RETHINK ELECTRIC

PROJECT:
SG - DARIEN

LOCATION:
8131 LEMONT ROAD
DARIEN IL 60516

SHEET TITLE:
BALLAST LEGEND

REVISION: 0
SHEET: PC-5

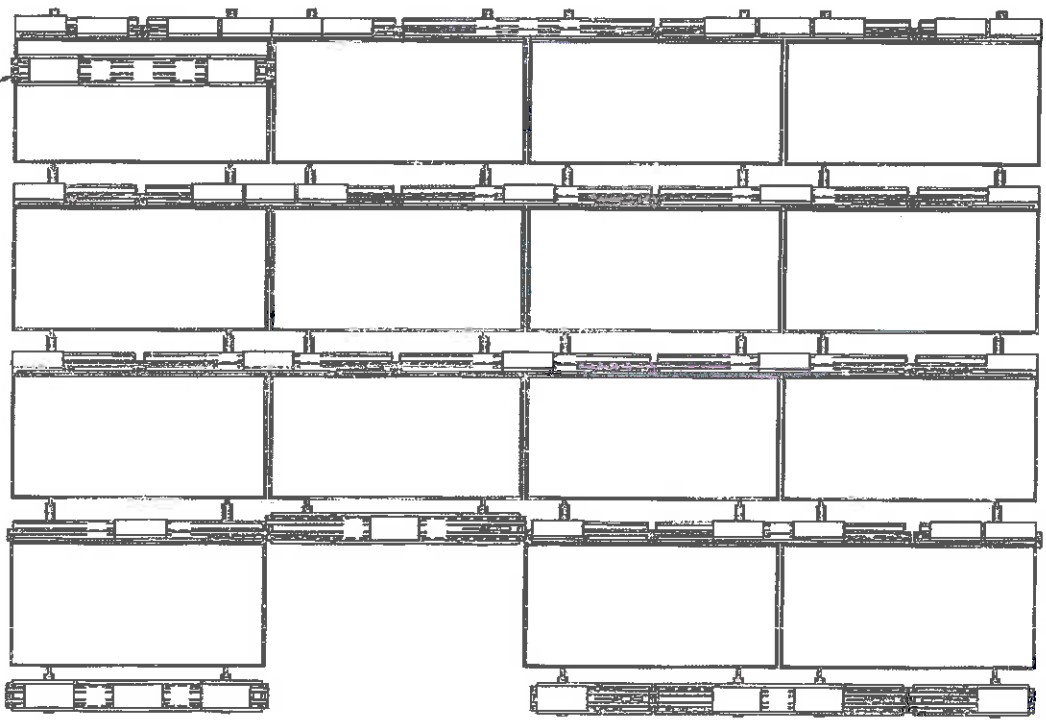

GENERIC BALLAST PLACEMENT LEGEND
SCALE: NTS

B
PC-5

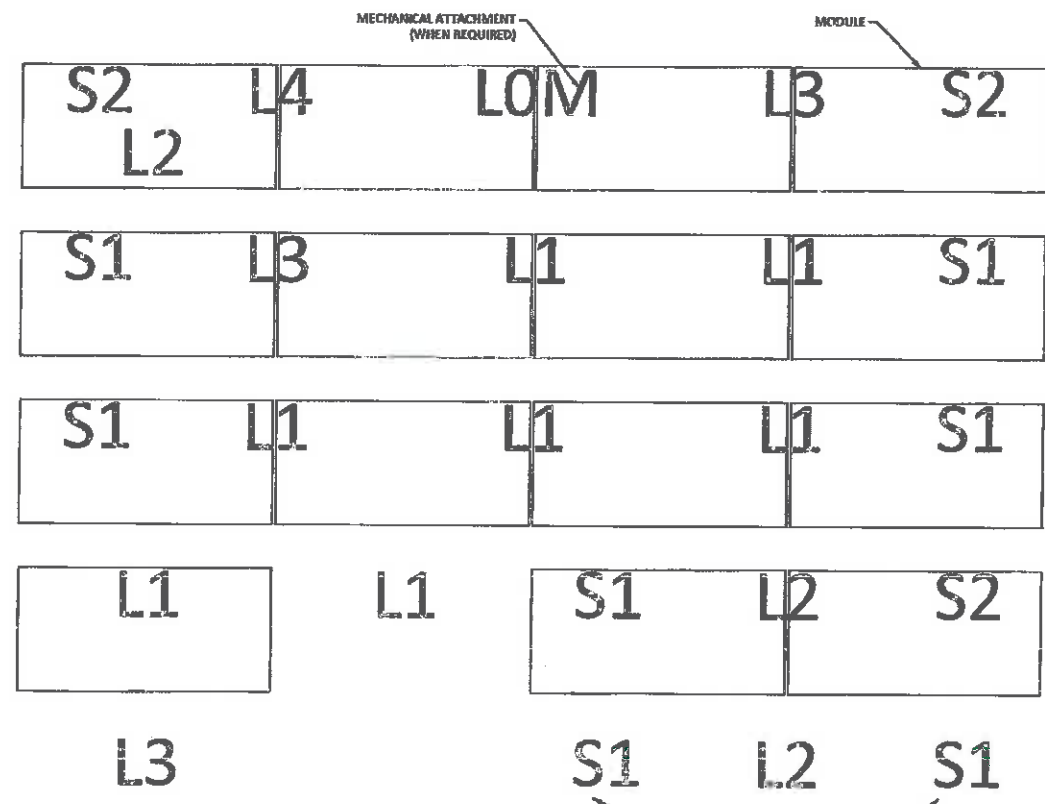

GENERIC TRAY, BALLAST, AND ATTACHMENT PLAN
SCALE: NTS

C
PC-5

TRAY AND BALLAST QUANTITY KEY:
"S"-SHORT TRAY
"L"-LONG TRAY
"B"-QUANTITY OF BALLAST BLOCK IN TRAY
"M"-MECHANICAL ATTACHMENT (WHEN REQUIRED)
SEE PROJECT PART QUANTITIES TABLE PC-2 FOR LONG AND SHORT TRAY PART NUMBERS.

NOTE:
REFERENCE THE BALLAST MAP SHEETS FOR ARRAY SPECIFIC BALLAST TRAY AND BALLAST BLOCK QUANTITY REQUIREMENTS.

ARRAY 1		ARRAY 2	
ROOF INFORMATION		ROOF INFORMATION	
ROOF HEIGHT (FT)	35	ROOF HEIGHT (FT)	35
PARAPET HEIGHT (FT)	0	PARAPET HEIGHT (FT)	0
ROOF TILT (DEG)	1	ROOF TILT (DEG)	1
ROOF TYPE	FPDM	ROOF TYPE	FPDM
SPECIFICATIONS		SPECIFICATIONS	
NUMBER OF MODULES	144	NUMBER OF MODULES	126
MODULE POWER (W)	365	MODULE POWER (W)	365
ARRAY OUTPUT (KW)	52.6	ARRAY OUTPUT (KW)	46.0
ARRAY AZIMUTH	179	ARRAY AZIMUTH	179
PART QUANTITIES		PART QUANTITIES	
ITEM	QTY	ITEM	QTY
STANDARD SUPPORTS	258	STANDARD SUPPORTS	216
NORTH SUPPORTS	30	NORTH SUPPORTS	36
SOUTH SUPPORTS	30	SOUTH SUPPORTS	36
LONG BALLAST TRAY	140	LONG BALLAST TRAY	132
SHORT BALLAST TRAY	38	SHORT BALLAST TRAY	24
CLAWS	288	CLAWS	252
BALLAST BLOCKS	174	BALLAST BLOCKS	155
LOADING DETAILS		LOADING DETAILS	
SINGLE MODULE WT (LB)	50.7	SINGLE MODULE WT (LB)	50.7
SINGLE CMU WT (LB)	32	SINGLE CMU WT (LB)	32
TOTAL ARRAY WT (LB)	15515	TOTAL ARRAY WT (LB)	13721
ARRAY AREA (SQ. FT)	4516	ARRAY AREA (SQ. FT)	3969
ARRAY LOAD (PSF)	3.4	ARRAY LOAD (PSF)	3.5

STAMP:



RACKING CONSTRUCTION SET
 1600 OSGOOD ST. SUITE 2023
 NORTH ANDOVER, MA 01845
 TEL: 978.688.4900
 www.panelclaw.com

© PANELCLAW, INC.
 ALL INFORMATION CONTAINED HEREIN IS THE
 SOLE PROPERTY OF PANELCLAW, INC.
 THE PURPOSE OF THIS DOCUMENT IS TO
 INCLUDE THE INSTALLATION OF PANELCLAW
 SOLAR PHOTOVOLTAIC MOUNTING SYSTEMS. DO
 NOT COPY OR REPRODUCE WITHOUT PERMISSION.

REV	DESCRIPTION	DATE	CHECK
0	Initial Ballast Map Layout	2020-09-02	MM
			BG

SCALE:

 ORIGINAL SIZE 36"X24"
 SHEET SIZE ARCH "D"

PREPARED FOR:
RETHINK ELECTRIC

PROJECT:
SG - DARIEN

LOCATION:
 8131 LEMONT ROAD
 DARIEN IL 60515

SHEET TITLE:
BALLAST LAYOUT - 1

REVISION: **0** SHEET: **PC-6**

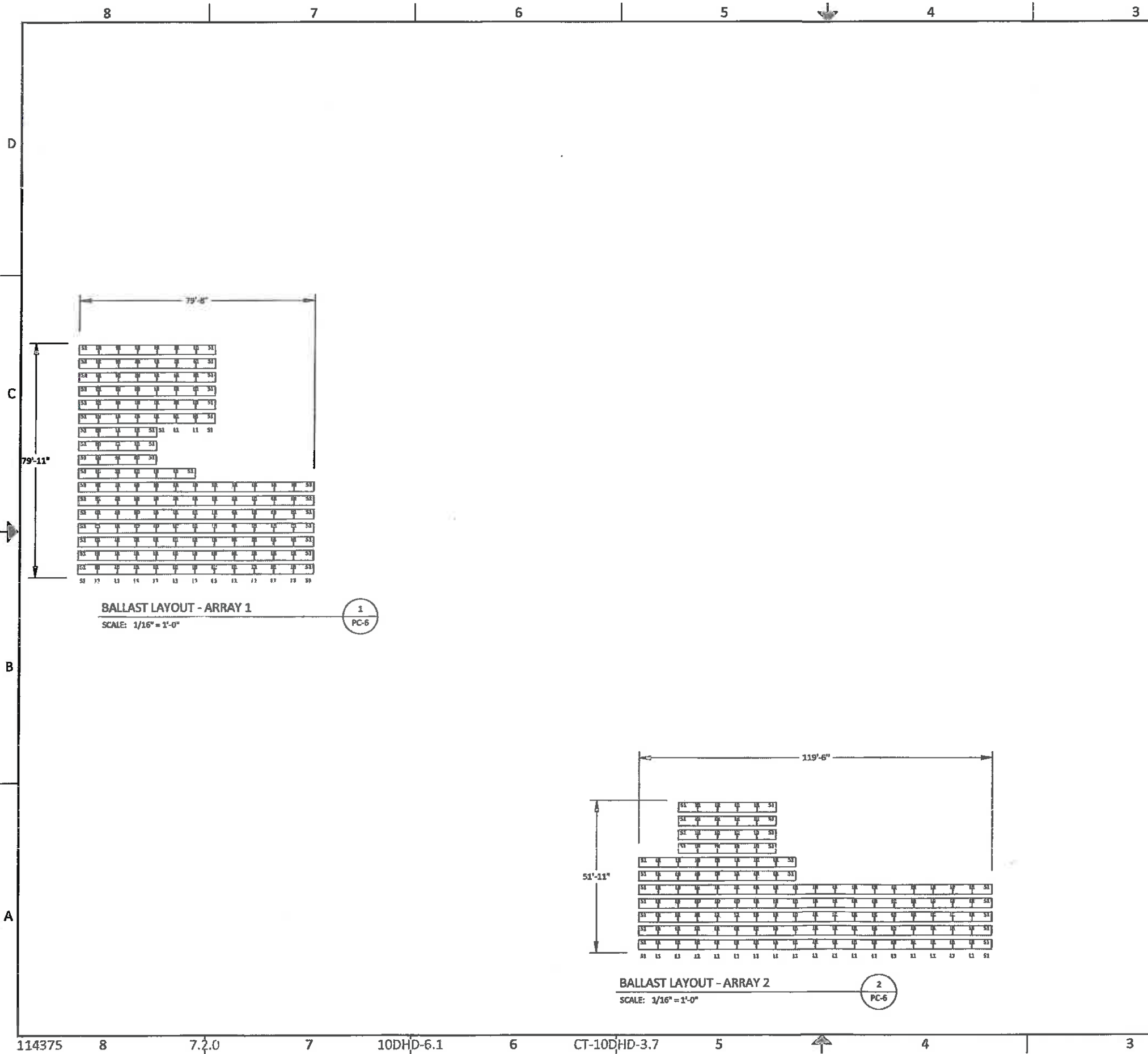

BALLAST LAYOUT - ARRAY 1
 SCALE: 1/16" = 1'-0" 1
PC-6

BALLAST LAYOUT - ARRAY 2
 SCALE: 1/16" = 1'-0" 2
PC-6

ARRAY 3	
ROOF INFORMATION	
ROOF HEIGHT (FT)	35
PARAPET HEIGHT (FT)	0
ROOF TILT (DEG)	1
ROOF TYPE	EPDM
SPECIFICATIONS	
NUMBER OF MODULES	34
MODULE POWER (W)	365
ARRAY OUTPUT (KW)	12.4
ARRAY AZIMUTH	179
PART QUANTITIES	
ITEM	QTY
STANDARD SUPPORTS	42
NORTH SUPPORTS	26
SOUTH SUPPORTS	26
LONG BALLAST TRAY	40
SHORT BALLAST TRAY	14
CLAWS	68
BALLAST BLOCKS	54
LOADING DETAILS	
SINGLE MODULE WT (LB)	50.7
SINGLE CMU WT (LB)	32
TOTAL ARRAY WT (LB)	4182
ARRAY AREA (SQ. FT)	1101
ARRAY LOAD (PSF)	3.8

STAMP:



PANELCLAW®

RACKING CONSTRUCTION SET
 1600 OSGOOD ST. SUITE 2023
 NORTH ANDOVER, MA 01845
 TEL: 978.688.4900
 www.panelclaw.com

© PROTEGEME, INC. ALL RIGHTS RESERVED. THIS DOCUMENT IS THE PROPERTY OF PANELCLAW, INC. THE PURCHASER OF THIS DOCUMENT IS TO FACILITATE THE CALCULATION OF PANELCLAW SOLAR PHOTOVOLTAIC SYSTEMS. DO NOT COPY OR REPRODUCE WITHOUT PERMISSION.

REV	DESCRIPTION	DATE
0	Initial Ballast Map Layout	2020-03-02

SCALE:
 0" 1/2" 1" 2"
 ORIGINAL SIZE 36"x24"
 SHEET SIZE ARCH "D"

PREPARED FOR:
RETHINK ELECTRIC

PROJECT:
SG - DARIEN

LOCATION:
 8131 LEMONT ROAD
 DARIEN IL 60516

SHEET TITLE:
BALLAST LAYOUT - 2

REVISION: 0 SHEET: PC-7

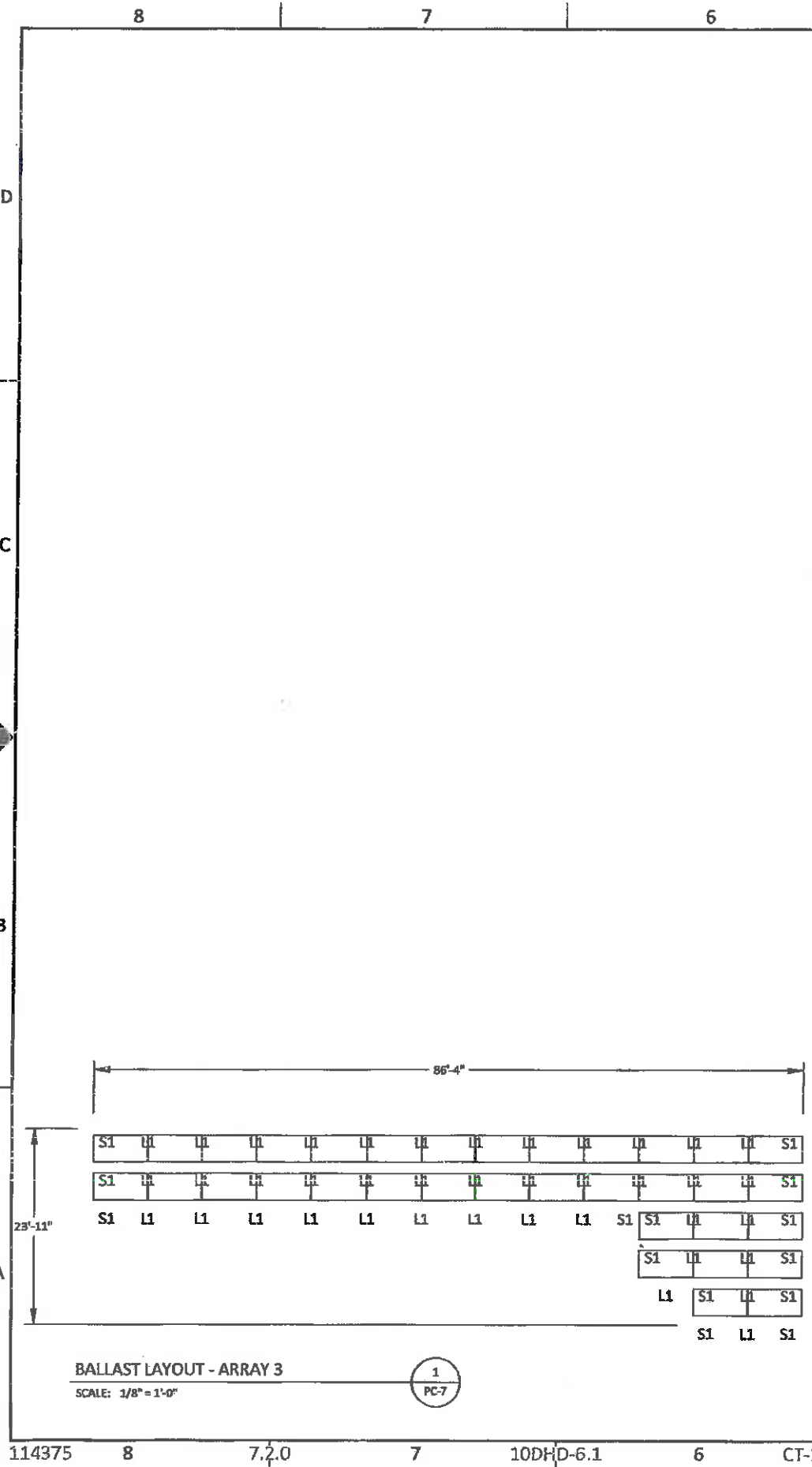

MEMO



East/West Views

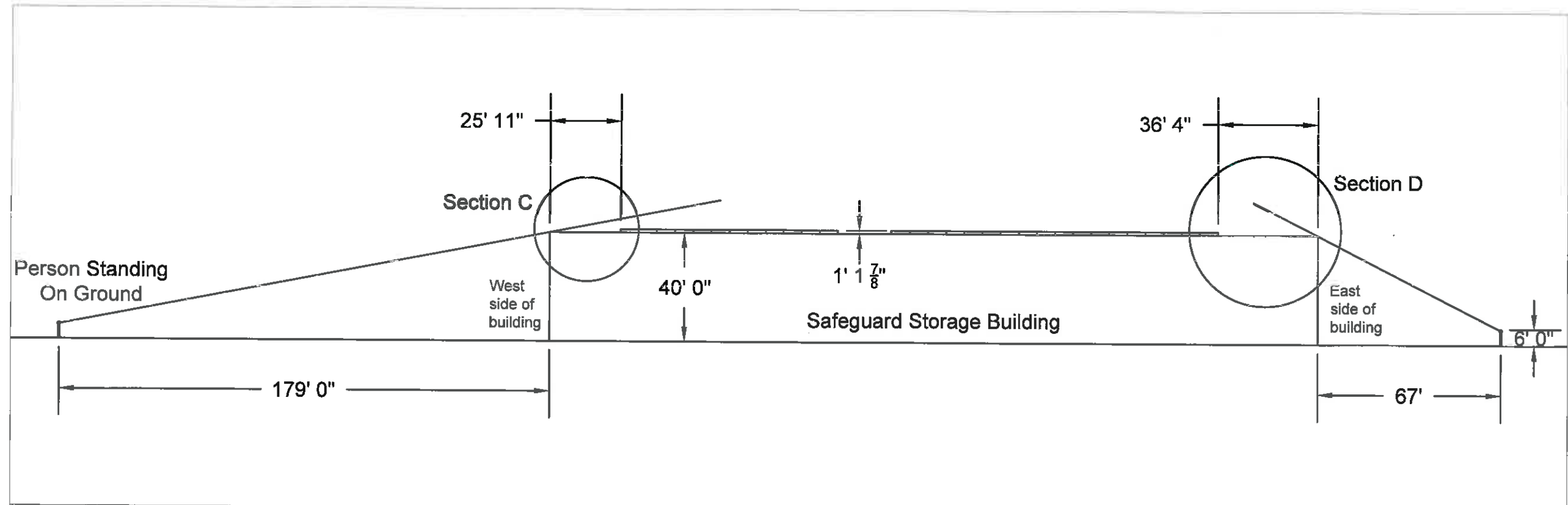

Section C

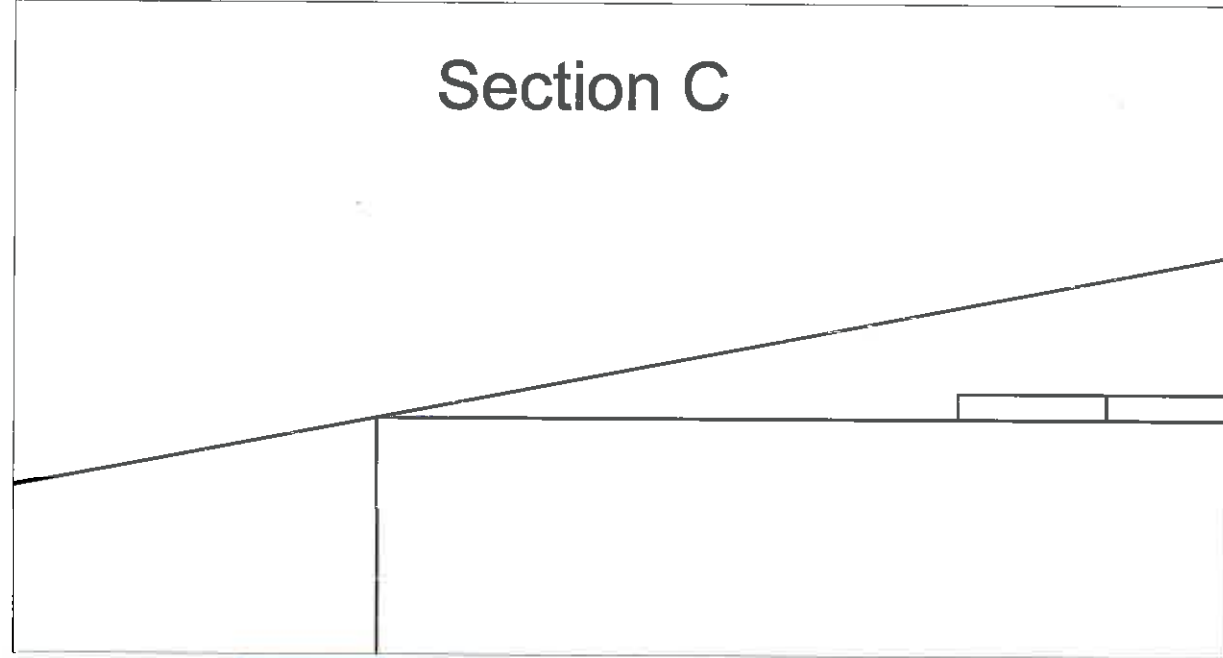

Section D

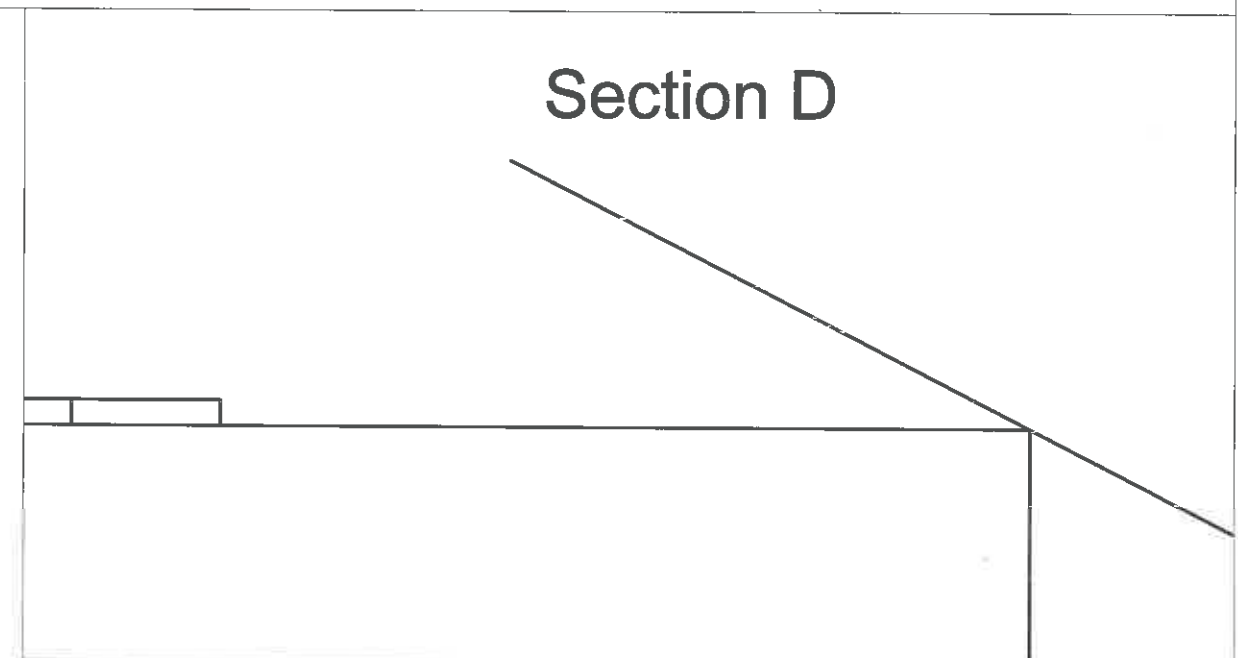

North/South Views

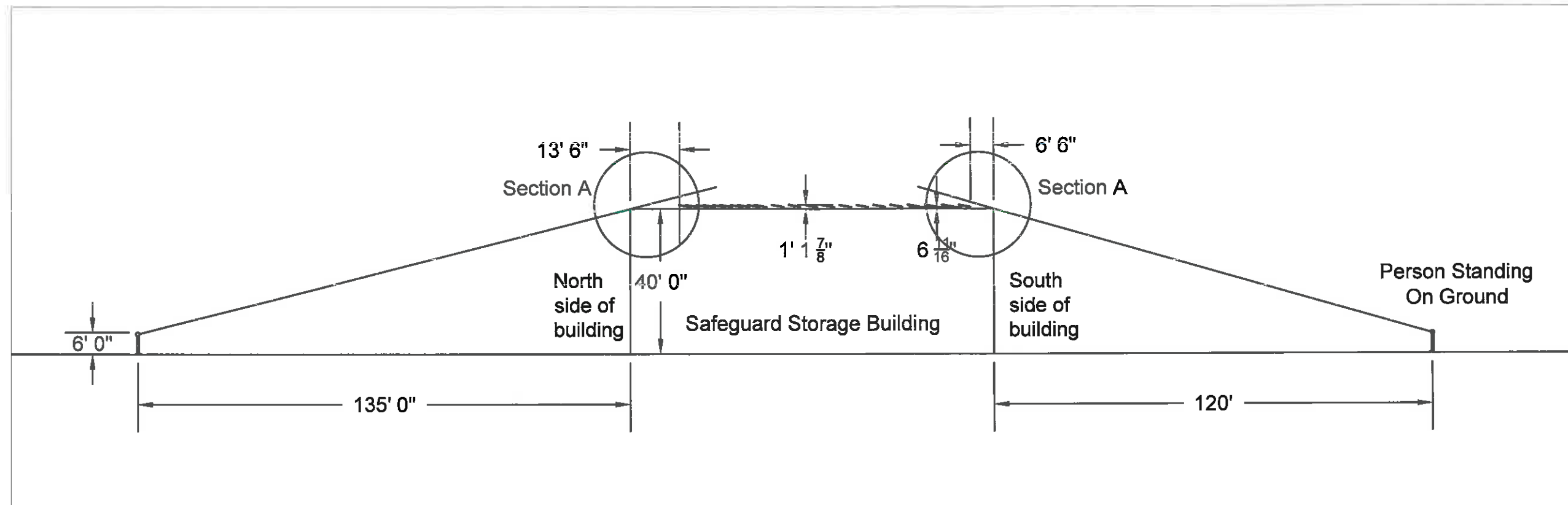

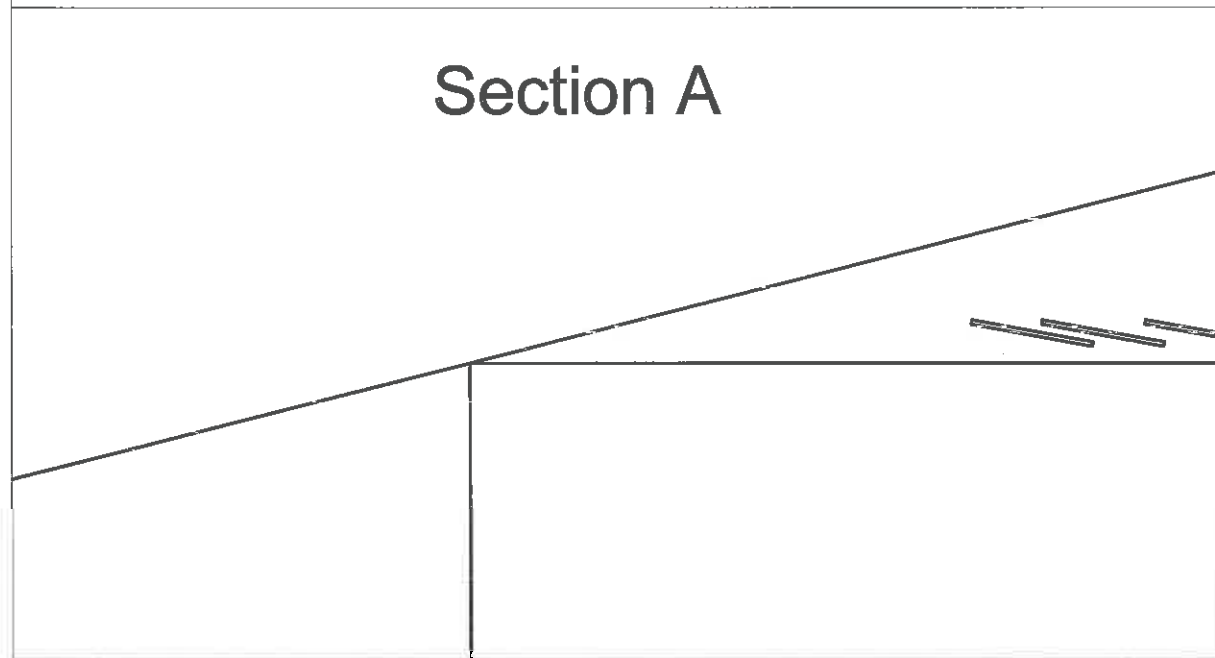

Section A

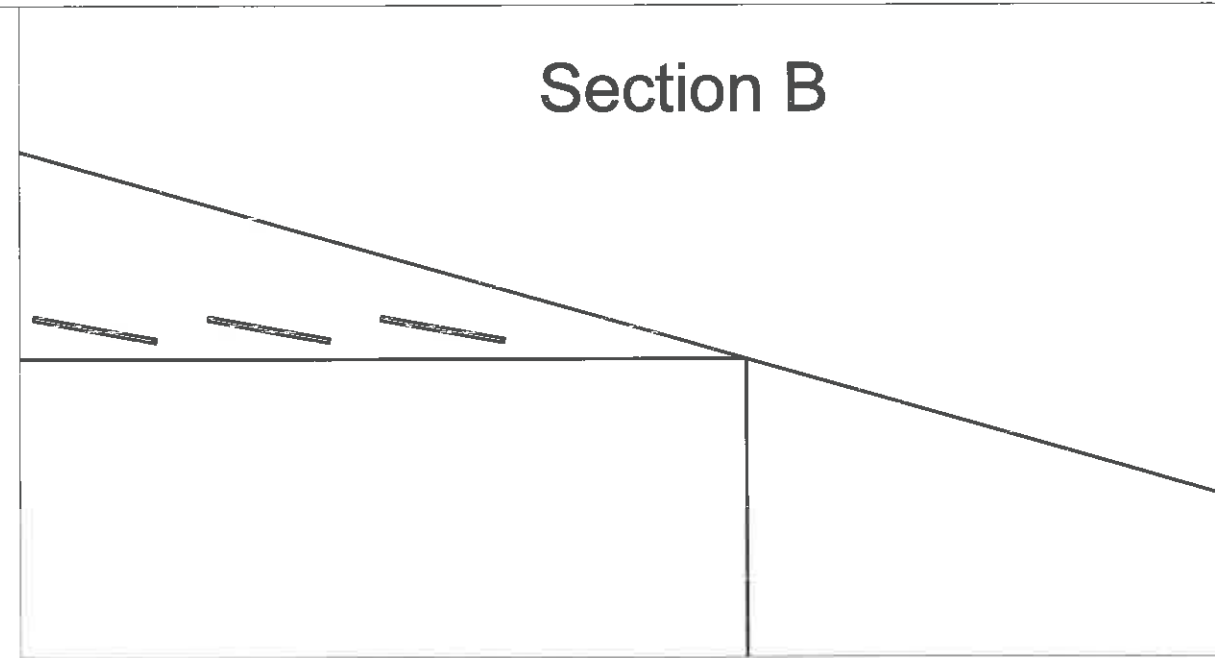

Section B

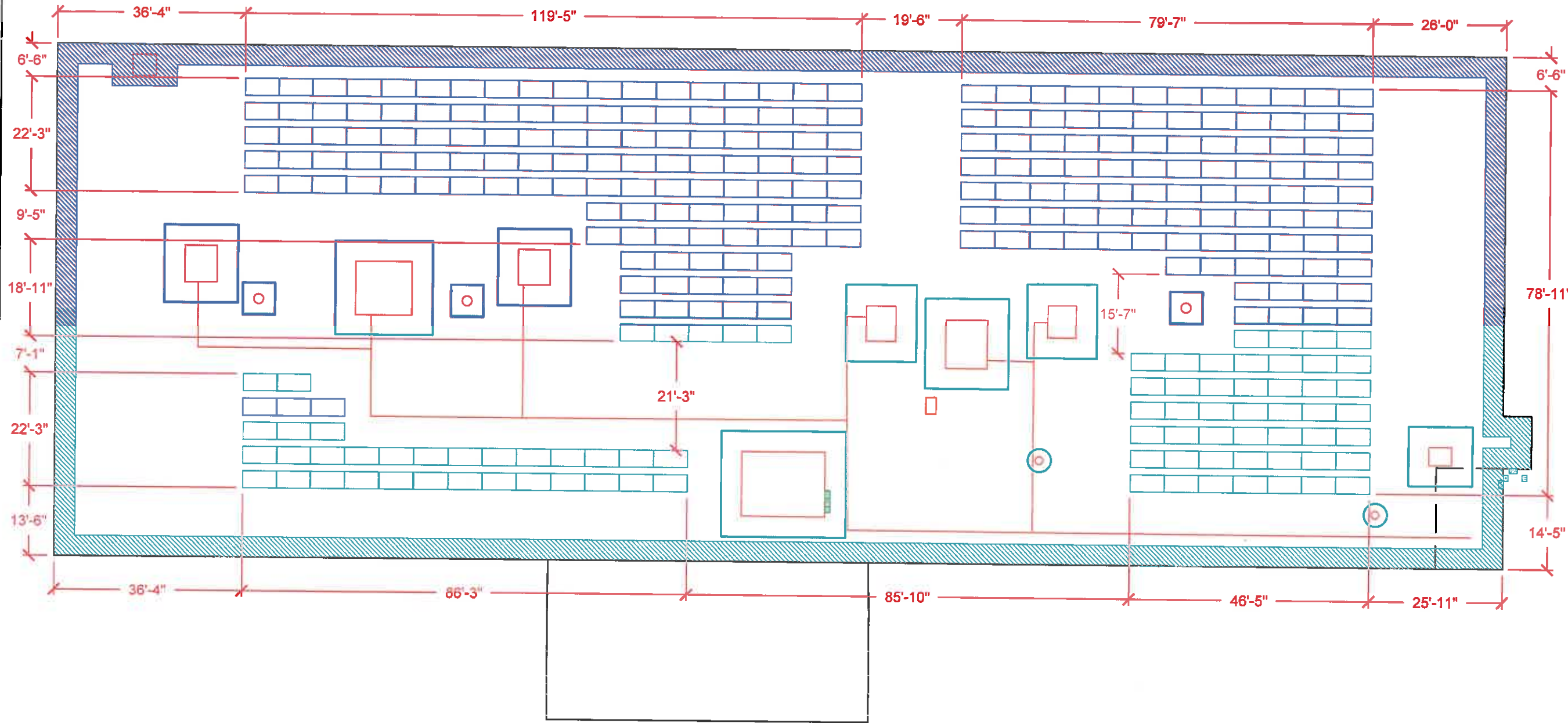



 RETHINK ELECTRIC
CONTRACTOR RETHINK ELECTRIC POLINA KOSEVA 850 N. CENTRAL AVE WOOD DALE, IL 60191 Phone: (630) 621-8009 Email: polina@rethinkelectric.com
DEVELOPER PIVOT ENERGY 1536 WYNKOOP ST., DENVER, CO 80202
PROJECT NAME & ADDRESS SAFEGUARD STORAGE 8131 LEMONT RD DARIEN, IL 60516
PROFESSIONAL ENGINEER STAMP
Rev A DATE: 10 March 2020
ROOF PLAN
PV 2.2

Dimension on North Side of Building



Dimension on South Side of Building



Dimension on East Side of Building



Dimension on West Side of Building



View from North Side of Building



View from South Side of Building



View from East Side of Building



View from West Side of Building





DuPage County
Information Technology Department
GIS Division
421 N County Farm Rd.
Wheaton, IL 60187
Ph# (630)407-5000
Email: gis@dupageco.org

DuPage Maps Portal:
<http://dupage.maps.arcgis.com/home>

DuPage County, Illinois Web Site:
www.dupageco.org



This map is for assessment purposes only.

Copyright DuPage 2018

CITY OF DARIEN
ZONING VARIATIONS
JUSTIFICATION NARRATIVE

Purpose

To be consistent and fair, the City is obligated to make decisions on zoning variation requests based on findings-of-fact. The Applicant should write a justification narrative that contains evidence (facts) that support a conclusion (finding) that the variation is necessary and would not cause problems. It should include: a) explanation of why the variation is being requested, b) describe the 'hardship condition' of the property that makes it difficult to conform, c) estimate the impact on neighbors, and d) respond to each of the decision criteria below.

Decision Criteria (See City Code Section 5A-2-2-3)

2a. The property in question cannot yield a reasonable return if permitted to be used only under the conditions allowed by the regulations in the zone.

2b. The plight of the owner is due to unique circumstances.

2c. The variation if granted will not alter the essential character of the locality.

3a. Essential Need? The owner would suffer substantial difficulty or hardship and not mere inconvenience or a decrease in financial gain if the variation is not granted.

3b. Problem with Property? There is a feature of the property such as slope or shape or change made to the property, which does not exist on neighboring properties, which makes it unreasonable for the owner to make the proposed improvement in compliance with the Zoning Code. Such feature or change was not made by the current owner and was not known to the current buyer at the time of purchase.

3c. Smallest Solution? There is no suitable or reasonable way to redesign the proposed improvements without incurring substantial difficulty or hardship or reduce the amount of variation required to make such improvements.

3d. Create Neighbor Problem? The variation, if granted, will not cause a substantial difficulty, undue hardship, unreasonable burden, or loss of value to the neighboring properties.

3e. Create Community Problem? The variation, if granted, may result in the same or similar requests from other property owners within the community, but will not cause an unreasonable burden or undesirable result within the community.

3f. Net Benefit? The positive impacts to the community outweigh the negative impacts.

3g. Sacrifice Basic Protections? The variation, if granted, will comply with the purposes and intent of the Zoning Code set forth in Section 5A-1-2(A) and summarized as follows; to lessen congestion, to avoid overcrowding, to prevent blight, to facilitate public services, to conserve land values, to protect from incompatible uses, to avoid nuisances, to enhance aesthetic values, to ensure an adequate supply of light and air, and to protect public health, safety, and welfare.



CITY OF DARIEN

DU PAGE COUNTY, ILLINOIS

ORDINANCE NO. _____

**AN ORDINANCE GRANTING A VARIATION FROM SECTION 5A-5-9-8(B) OF THE
DARIEN ZONING ORDINANCE**

(PZC 2020-06 8131 Lemont Road)

ADOPTED BY THE

MAYOR AND CITY COUNCIL

OF THE

CITY OF DARIEN

THIS 20th DAY OF JULY, 2020

**Published in pamphlet form by authority of
the Mayor and City Council of the City of
Darien, DuPage County, Illinois, this
_____ day of July, 2020.**

ORDINANCE NO. _____

**AN ORDINANCE GRANTING A VARIATION FROM SECTION 5A-5-9-8(B) OF THE
DARIEN ZONING REGULATIONS**

(PZC 2020-06 8131 Lemont Road)

WHEREAS, the City of Darien is a home rule unit of local government pursuant to the provisions of Article VII, Section 6 of the Illinois Constitution of 1970; and

WHEREAS, as a home rule unit of local government, the City may exercise any power and perform any function pertaining to its government except as limited by Article VII, Section 6; and

WHEREAS, the property legally described in Section 1 (the “Subject Property”), is zoned OR&I Office, Research and Light Industrial District pursuant to the Darien Zoning Regulations; and

WHEREAS, the petitioner has requested approval of a variation from the terms of the Darien Zoning Regulations, Section 5A-5-9-8(B)5 of the City Code, that otherwise requires solar panels be screened with a parapet or screening wall when in excess of 6 inches in height, to allow for the installation of solar panels , which have a height of 14 inches, without such a wall, and

WHEREAS, pursuant to proper legal notice, a Public Hearing on said petition for variation was held before the Planning and Zoning Commission on June 17, 2020; and

WHEREAS, the Planning and Zoning Commission at its regular meeting of June 17, 2020, recommended approval of the petition herein described and has forwarded its findings and recommendation of approval to the City Council; and

WHEREAS, on June 20, 2020, the Municipal Services Committee of the City Council reviewed the petition and has forwarded its recommendation of approval of said petition to the City Council; and

ORDINANCE NO. _____

WHEREAS, the City Council has reviewed the findings and recommendations described above and now determines to grant the petition subject to the terms, conditions and limitations described below.

NOW, THEREFORE, BE IT ORDAINED BY THE CITY COUNCIL OF THE CITY OF DARIEN, DU PAGE COUNTY, ILLINOIS, IN THE EXERCISE OF ITS HOME RULE POWERS, as follows:

SECTION 1: Subject Property. This Ordinance is limited and restricted to the property generally located at 8131 Lemont Road, Darien, Illinois, and legally described as follows:

PARCEL 1: LOTS 6 AND 7 IN DARIEN CORPORATE CENTRE, BEING A SUBDIVISION OF PART OF THE NORTHWEST 1/4 OF SECTION 32, TOWNSHIP 38 NORTH, RANGE 11 EAST OF THE THIRD PRINCIPAL MERIDIAN, ACCORDING TO THE PLAT THEREOF RECORDED JUNE 29, 2000 AS DOCUMENT R2000-099131, IN DUPAGE COUNTY, ILLINOIS.

PARCEL 2: EASEMENT FOR THE BENEFIT OF PARCEL 1 AS CREATED BY THE PLAT OF DARIEN CORPORATE CENTRE, RECORDED JUNE 29, 2000 AS DOCUMENT R2000-099131, FOR INGRESS AND EGRESS OVER THE AREAS PLATTED AND DESIGNATED "INGRESS AND EGRESS EASEMENT".

PIN: 09-32-106-035

SECTION 2: Variations from Zoning Ordinance Granted. A variation is hereby granted from Section 5A-5-9-8(B)5 of the City Zoning Ordinance, that otherwise requires solar panels be screened with a parapet or screening wall when in excess of 6 inches in height, to allow for the installation of solar panels which have a height of 14 inches without such a wall,.

SECTION 3: Home Rule. This ordinance and each of its terms shall be the effective legislative act of a home rule municipality without regard to whether such ordinance should (a) contain terms contrary to the provisions of current or subsequent non-preemptive state law, or (b) legislate in a manner or regarding a matter not delegated to municipalities by state law. It is the intent of the corporate authorities of the City of Darien that to the extent of the terms of this ordinance should

ORDINANCE NO. _____

be inconsistent with any non-preemptive state law, that this ordinance shall supercede state law in that regard within its jurisdiction.

SECTION 4: Effective Date. This Ordinance shall be in full force and effect from and after its passage and approval as provided by law.

PASSED BY THE CITY COUNCIL OF THE CITY OF DARIEN, DU PAGE COUNTY, ILLINOIS, this 20th day of July, 2020.

AYES: _____

NAYS: _____

ABSENT: _____

APPROVED BY THE MAYOR OF THE CITY OF DARIEN, DU PAGE COUNTY, ILLINOIS, this 20th day of July, 2020.

JOSEPH A. MARCHESE, MAYOR

ATTEST:

JOANNE E. RAGONA, CITY CLERK

APPROVED AS TO FORM:

CITY ATTORNEY

AGENDA MEMO
City Council
July 20, 2020

ISSUE STATEMENT

A Resolution Approving an Intergovernmental Agreement for Participation in the DuPage County Local Government Covid-19 Reimbursement Program.

RESOLUTION **BACKUP**

BACKGROUND HISTORY

The Intergovernmental agreement with DuPage County is the mechanism set up to provide the city with reimbursement expenses incurred due to Covid 19. The County of DuPage received approximately one hundred sixty-one million dollars (\$161,000,000) from the United States Government pursuant to the Coronavirus Aid, Relief, and Economic Security Act. The CARES Act provides that payments from the Coronavirus Relief Fund may only be used to cover expenses which:

- (1) Are necessary expenditures incurred due to the public health emergency with respect to the Coronavirus Disease 2019 (COVID-19)
- (2) Were not accounted for in the budget most recently approved as of March 27, 2020 (the date of enactment of the CARES Act) for the local government
- (3) Were incurred during the period that begins on March 1, 2020 and ends on December 30, 2020. The United States Department of Treasury has issued guidelines with regards to the authorized use of funds allocated to local governments under the CARES Act.

The County is not required to disburse any funds to local municipalities within its geographic boundaries but they have agreed to reimburse for certain expenses allowed in the Department of Treasury guidelines. The proposed agreement was developed by the County with input from the DuPage Mayors and Managers Conference with the goal of one standard agreement throughout DuPage County.

In summary, the expenses eligible for reimbursement include:

- The cost of tangible goods and services. Examples of “Tangible Goods” would include, but are not limited to, personal protection and medical equipment, sanitation and disinfectant products, software, laptops and technology equipment necessary for employees to telecommute. “Services” as used in this definition means actions or intangible things that were performed by individuals who are not municipal employees such as contractual cleaning companies. (estimated at \$40,000 as of May 31, 2020)
- Payroll costs for municipal employees where such employees time was substantially dedicated to mitigating the spread or responding to the public health emergency (amount to be determined by internal analysis)
- Costs for economic development programs designed to support and defray the costs of local businesses (within the geographic boundaries of DuPage County) negatively impacted by the executive orders which required such businesses be closed or have their operations seriously curtailed. (estimated at \$295,000)

STAFF/COMMITTEE RECOMMENDATION

Mayor Marchese and staff recommend approval of a Resolution Approving an Intergovernmental Agreement for Participation in the DuPage County Local Government Covid-19 Reimbursement Program.

ALTERNATE CONSIDERATION

N/A

DECISION MODE

This will be on the July 20, 2020, City Council agenda for formal approval.



DUPAGE COUNTY

District 1

Donald Puchalski
Ashley Selmon
Sam Tornatore

District 2

Elizabeth Chaplin
Peter DiCianni
Sean Noonan

District 3

Greg Hart
Brian Krajewski
Julie Renehan

District 4

Grant Eckhoff
Tim Elliott
Mary FitzGerald Ozog

District 5

Sadia Covert
Dawn DeSart
James Healy

District 6

Robert Larsen
Sheila Rutledge
James Zay

Daniel J. Cronin
County Board Chairman

(630) 407-6060
chairman@dupageco.org

July 1, 2020

Steve Chirico, President
DuPage Mayors & Managers Conference
1220 Oak Brook Road
Oak Brook, IL 60523

RE: CARES Act Allocation

Dear President Chirico and Members of DMMC,

Yesterday, the State of Illinois announced its Local Coronavirus Urgent Remediation Emergency (CURE) program to distribute funds to local governments that did not receive a direct allocation under the federal CARES Act. The program sets aside funds for municipalities and counties, local health departments, other units of local government, and a reserve amount to be distributed on a needs-basis later in the calendar year.

Following DuPage's model, the State's municipal reimbursement program allocates funds on a per-capita basis (\$41.50), establishes a certification and agreement process, places a cap on each local government distribution, and requires the submittal of documented COVID-19 related expenses to a third party for review and approval of eligible expenses. Accordingly, municipalities located in multiple counties and also receiving funds from the State will find it seamless to request funds from both.

Although the State is not allocating \$51.84 per-capita as previously referenced by DMMC, DuPage County remains committed to distributing these funds to our municipal partners and will consider additional allocations later in the year if permitted.

Regards,

Daniel J. Cronin
Chairman
DuPage County Board



RESOLUTION NO. _____

**A RESOLUTION APPROVING AN INTERGOVERNMENTAL AGREEMENT
BETWEEN THE CITY OF DARIEN AND DUPAGE COUNTY FOR
PARTICIPATION IN DUPAGE COUNTY LOCAL GOVERNMENT
COVID-19 REIMBURSEMENT PROGRAM**

WHEREAS, the City of Darien is a home rule unit of local government pursuant to the provisions of Article VII, Section 6, of the Illinois Constitution of 1970; and

WHEREAS, as a home rule unit of local government, the City may exercise any power and perform any function pertaining to its government except as limited by Article VII, Section 6; and

WHEREAS, the Illinois Constitution and the Intergovernmental Cooperation Act (5 ILCS 220/ *et. seq*) authorize units of local government, including counties and municipalities, to contract or otherwise associate among themselves in any manner not prohibited by law and to jointly exercise any power, privilege or authority conferred upon them by law; and

WHEREAS, Article 7, Section 10 of the Illinois Constitution of 1971 and the Illinois Intergovernmental Cooperation Act 5 ILCS 220/1 *et seq.* allow units of public entities to enter into intergovernmental agreements in the furtherance of their governmental purposes; and

WHEREAS, the County of DuPage received approximately one hundred sixty-one million dollars (\$161,000,000) from the United States Government pursuant to the Coronavirus Aid, Relief, and Economic Security Act (“CARES Act”); and

WHEREAS, the CARES Act provides for payments to local governments navigating the impact of the COVID-19 outbreak via the Coronavirus Relief Fund; and

WHEREAS, the County of DuPage, as the jurisdiction responsible for disbursement of funds under the CARES Act, finds that it is appropriate to use these funds to defray certain costs incurred by the Municipality related to the coronavirus emergency; and

RESOLUTION NO. _____

NOW, THEREFORE, BE IT RESOLVED BY THE MAYOR AND CITY COUNCIL OF THE CITY OF DARIEN, DU PAGE COUNTY, ILLINOIS, pursuant to its home-rule powers, as follows:

SECTION 1: Authorization. The City Council of the City of Darien hereby authorizes the Mayor to approve an INTERGOVERNMENTAL AGREEMENT BETWEEN THE CITY OF DARIEN AND DUPAGE COUNTY FOR PARTICIPATION IN DUPAGE COUNTY LOCAL GOVERNMENT COVID-19 REIMBURSEMENT PROGRAM subject to Attorney’s final review in and substantially the same form as a copy of which is attached hereto as “[Exhibit 1](#)”.

SECTION 2: Effective Date. This Resolution shall be in full force and effect from and after its passage and approval.

PASSED BY THE CITY COUNCIL OF THE CITY OF DARIEN, DU PAGE COUNTY, ILLINOIS, this 20th day of July, 2020.

AYES: _____

NAYS: _____

ABSENT: _____

RESOLUTION NO. _____

**APPROVED BY THE MAYOR OF THE CITY OF DARIEN, DU PAGE COUNTY,
ILLINOIS, this this 20th day of July, 2020.**

JOSEPH A. MARCHESE, MAYOR

ATTEST:

JOANNE E. RAGONA, CITY CLERK

APPROVED AS TO FORM:

CITY ATTORNEY

Resolution

FI-R-0420-20

INTERGOVERNMENTAL AGREEMENT
 BETWEEN THE COUNTY OF DUPAGE AND
 VARIOUS MUNICIPALITIES
 FOR THE REIMBURSEMENT OF ELIGIBLE COVID-19
 EXPENSES

WHEREAS, the Illinois Constitution and the Intergovernmental Cooperation Act (5 ILCS 220/ et. seq) authorize units of local government, including counties and municipalities, to contract or otherwise associate among themselves in any manner not prohibited by law and to jointly exercise any power, privilege or authority conferred upon them by law; and

WHEREAS, Article 7, Section 10 of the Illinois Constitution of 1971 and the Illinois Intergovernmental Cooperation Act 5 ILCS 220/1 et seq. allow units of public entities to enter into intergovernmental agreements in the furtherance of their governmental purposes; and

WHEREAS, the County Board of DuPage County (the County) received approximately one hundred sixty-one million dollars (\$161,000,000) from the United States Government pursuant to the Coronavirus Aid, Relief, and Economic Security Act (“CARES Act”); and

WHEREAS, the CARES ACT provides for payments to local governments navigating the impact of the COVID-19 outbreak via the Coronavirus Relief Fund; and

WHEREAS, the County, as the jurisdiction responsible for disbursement of funds under the CARES ACT, finds that it is appropriate to use these funds to defray certain costs incurred by the municipalities related to the coronavirus emergency; and

WHEREAS, the County of DuPage believes it is necessary to enter into an Agreement with the following municipalities to govern the reimbursement of COVID-19 related expenses,

WHEREAS, the County of DuPage seeks to enter into agreements with: the Village of Addison, City of Aurora, Village of Bartlett, Village of Bensenville, Village of Bloomingdale, Village of Bolingbrook, Village of Burr Ridge, Village of Carol Stream, Village of Clarendon Hills, City of Darien, Village of Downers Grove, City of Elmhurst, Village of Glendale Heights, Village of Glen Ellyn, Village of Hanover Park, Village of Hinsdale, Village of Itasca, Village of Lemont, Village of Lisle, Village of Lombard, City of Naperville, Village of Oak Brook, City of Oakbrook Terrace, Village of Roselle, City of St. Charles, Village of Villa Park, City of Warrenville, Village of Wayne, City of West Chicago, Village of Westmont, City of Wheaton, Village of Willowbrook, Village of Winfield, City of Wood Dale, and Village of Woodridge, and

WHEREAS, an Agreement has been prepared and attached hereto which outlines the financial arrangement between the County and the municipalities and the process by which municipalities may apply for reimbursement.

NOW, THEREFORE, BE IT RESOLVED by the County Board of DuPage County that the Clerk and Chairman of the Board be hereby directed and authorized to execute the referenced Agreement with the above referenced municipalities; and

BE IT FURTHER RESOLVED, that the DuPage County Clerk be directed to provide

Resolution

FI-R-0420-20

copies of this Resolution to the municipalities listed above.

Enacted and approved this 14th day of July, 2020 at Wheaton, Illinois.

DANIEL J. CRONIN, CHAIRMAN
DU PAGE COUNTY BOARD

Attest: _____
JEAN KACZMAREK, COUNTY CLERK

**INTERGOVERNMENTAL AGREEMENT FOR PARTICIPATION IN DUPAGE COUNTY
LOCAL GOVERNMENT COVID-19 REIMBURSEMENT PROGRAM.**

THIS AGREEMENT is made and entered into on this 14th day of July, 2020 by and between the County of DuPage, a body politic and corporate, hereinafter referred to as "COUNTY" and the municipality of City of Darien, an unit of municipal government, hereinafter referred to as "MUNICIPALITY", and collectively referred to as "the Parties".

RECITALS

WHEREAS, the Illinois Constitution and the Intergovernmental Cooperation Act (5 ILCS 220/ et. seq) authorize units of local government, including counties and municipalities, to contract or otherwise associate among themselves in any manner not prohibited by law and to jointly exercise any power, privilege or authority conferred upon them by law; and

WHEREAS, Article 7, Section 10 of the Illinois Constitution of 1971 and the Illinois Intergovernmental Cooperation Act 5 ILCS 220/1 et seq. allow units of public entities to enter into intergovernmental agreements in the furtherance of their governmental purposes; and

WHEREAS, the County of DuPage received approximately one hundred sixty-one million dollars (\$161,000,000) from the United States Government pursuant to the Coronavirus Aid, Relief, and Economic Security Act ("CARES Act"); and

WHEREAS, the CARES Act provides for payments to local governments navigating the impact of the COVID-19 outbreak via the Coronavirus Relief Fund; and

WHEREAS, the CARES Act provides that payments from the Coronavirus Relief Fund may only be used to cover expenses which: (1) are necessary expenditures incurred due to the public health emergency with respect to the Coronavirus Disease 2019 (COVID-19); (2) were not accounted for in the budget most recently approved as of March 27, 2020 (the date of enactment of the CARES Act) for the local government; and (3) were incurred during the period that begins on March 1, 2020 and ends on December 30, 2020; and

WHEREAS, the County of DuPage was eligible to receive payments under the CARES Act, as it is a unit of local government in excess of 500,000 residents: and

WHEREAS, the United States Department of Treasury has issued guidelines with regards to the authorized use of funds allocated to local governments under the CARES Act; and

WHEREAS, neither the CARES Act, the United States Department of Treasury, nor state law, requires that the County disburse any funds to local municipalities within its geographic boundaries; and

WHEREAS, under the CARES Act, the County is ultimately responsible for any expenditures from CARES Act funds; and

WHEREAS, much uncertainty remains regarding future costs the County and local municipalities will be forced to bear related to the coronavirus emergency, and

WHEREAS, much uncertainty exists as to the potential for future allocations of federal or state monies to defray those future costs, and

WHEREAS, this agreement is intended to promote the most efficient distribution of resources which have been made available to the State of Illinois and the County of DuPage to benefit the citizens of DuPage County, and

WHEREAS, under the CARES Act, should the Office of the Inspector General determine that the funds were used in a manner contrary to the intent of the legislature or contrary to the United States' Department of Treasury guidelines, the CARES ACT provides that the federal government may recoup the improperly spent funds from the County; and

WHEREAS, the County, those municipalities within DuPage County, and their residents, have suffered secondary effects of the coronavirus emergency, as the State of Illinois has ordered the closure of non-essential businesses; and

WHEREAS, the County of DuPage, as the jurisdiction responsible for disbursement of funds under the CARES Act, finds that it is appropriate to use these funds to defray certain costs incurred by the Municipality related to the coronavirus emergency; and

WHEREAS, the disbursement of funds under the CARES Act to the Municipality is in the best interests of the County, the Municipality and their residents.

NOW, THEREFORE, in consideration of the mutual covenants and Agreements contained herein, the Parties hereby agree as follows:

1.0 Recitals, Definitions, and Purpose.

1.1 Recitals Incorporated. The recitals set forth above are incorporated in this Agreement by reference and made a part of this Intergovernmental Agreement ("IGA").

1.2 Definitions.

- A. "CARES Act funds"** shall refer to funds which have been allocated to DuPage County under the Coronavirus Aid, Relief, and Economic Security Act ("CARES Act") of which DuPage County is responsible for the disposition.
- B. "Forms"** shall refer to forms or application documents used to seek reimbursement of coronavirus related expenses under this agreement.
- C. "Expenses"** shall refer to the cost of tangible goods and services which (1) were necessary expenditures incurred due to the public health emergency with respect to the Coronavirus Disease 2019 (COVID-19); (2) were not accounted for in the budget most recently approved as of March 27, 2020 (the date of enactment of the CARES Act) for the local government; and (3) were incurred during the period that begins on March 1, 2020 and ends on December 30, 2020. Examples of "Tangible Goods" would include, but are not limited to, personal protection and medical equipment, sanitation and disinfectant products, software, laptops and technology equipment necessary for employees to telecommute. "Services" as used in this definition means actions or intangible things which were performed by individuals who are not municipal employees. Further, "Expenses" shall include payroll costs for municipal employees where such employees time was substantially dedicated to mitigating the spread or responding to the public

health emergency and/or who have been reassigned from their budgeted role to a different function to substantially support COVID-19 related activities. "Expenses" shall not include the complete payroll costs for employees who are not substantially dedicated to the mitigation or response to the public health emergency, except as set forth in 5.1 of this Agreement. Expenses may also include economic development programs designed to support and defray the costs of local businesses (within the geographic boundaries of DuPage County) negatively impacted by the executive orders which required such businesses be closed or have their operations seriously curtailed.

D. All other words used in this agreement which are not specifically defined shall have their normal and ordinary meaning.

1.3 Purpose. The purpose of this Agreement is to establish a contractual relationship between the County and Municipality with regards to the proposed reimbursement of municipal expenses associated with the coronavirus emergency from federal CARES Act funds which the United States Federal Government has disbursed to the County. The County has, by resolution, created the DuPage County Local Government COVID-19 Reimbursement program. This agreement shall remain in effect between the parties to govern the form of applications for reimbursement, the review of applications, the criteria for reimbursable expenses, the retention of documents, and other material terms governing the processing of reimbursement applications.

2.0 Obligations of the County

2.1 Generally. The County, by and through its Finance Department or Third-Party Consultant hired by the County, shall process requests for reimbursement received by Municipality subject to the requirements set forth herein.

2.2 Submittal does not guarantee approval. The County, by receiving and processing the reimbursement requests of Municipality, does not guarantee approval of the reimbursement requests by the DuPage County Board, the DuPage County Finance Department, the United States

Department of Treasury, or the Office of the Inspector General.

2.3 No further obligations. The County shall have no further obligations under this IGA other than those expressly set forth.

3.0 Obligations of the Municipality

3.1 Generally. In order to submit requests for reimbursement of coronavirus emergency related expenditures, Municipality agrees to submit the forms, certifications and documentations set forth in this IGA for any expense for which Municipality seeks reimbursement under this Agreement. Municipality agrees that the sole and exclusive decision as to whether or not Municipalities request is granted lies within the discretion of the DuPage County Board, and that submission of expenses for reimbursement does not obligate the County to agree to reimburse those expenses. Municipality agrees that the County Board, through its Finance Department or Third-Party Administrator, may reject expenses which are clearly not permitted uses for CARES ACT funds such as using the funds for revenue replacement.

4.0 Form of Expense Submittals, Certification, failure to use form or comply with criteria

4.1 Generally. The Parties agree that expenses for which Municipality seeks reimbursement shall be submitted in a manner and on forms created by the Third Party Administrator hired by the County to process reimbursement requests. County and Third Party Administrator shall work collaboratively with Municipality and DuPage Mayors and Managers Conference to ensure that the forms and process properly balance administrative convenience to the Parties and provide sufficient information for the County Board to issue a reimbursement.

4.2 Certification. Each request for reimbursement shall be accompanied by a certification wherein the Mayor/President, certifies that the expenses for which Municipality seeks reimbursement: (i) are necessary expenditures incurred due to the public health emergency with response to the Coronavirus Disease 2019, (ii) which were not accounted for in the most recently approved budget of the municipality, as of March 27, 2020, (iii) were

incurred during the period between March 1, 2020 and December 30, 2020. By entering into the IGA, Municipality authorizes its Mayor or President to sign such certification on behalf of Municipality.

4.3 Failure to comply with Department of Treasury Guidelines. The County reserves the right to reject any reimbursement which it feels, in its sole and exclusive discretion, does not meet the criteria of the CARES Act or United States Department of Treasury guidelines associated with disbursement of funds under the CARES Act. Such rejection may be made by the DuPage County Board. This section shall not be held to restrict the County Finance Department or Third-Party Administrator from rejecting requests which clearly fail to comply with the CARES Act or with Department of Treasury guidelines.

5.0 Expenses to be reimbursed; Caps of maximum amount of reimbursements available to Municipality; prohibition on duplicate reimbursement.

5.1 Municipality may submit expenses as set forth in section 1.2(c) of this Agreement. Where submitted expenses are seeking reimbursement for employee payroll, the County requires that the expenses be separated into two categories. The first category shall be employees whose time was substantially dedicated to mitigating the spread or responding to the public health emergency and/or who have been reassigned from their budgeted role to a different function to substantially support COVID-19 related activities. For purposes of this section "substantially dedicated" shall mean that sixty percent (60%) or more of the employees' time was dedicated to mitigating the spread or responding to the public health emergency related to COVID-19. Municipality may submit, and the County Board will consider, reimbursing 100% of the salary of "substantially dedicated" employees. The second category shall consist of employees whose time is not "substantially dedicated" to mitigating the spread of or responding to the COVID-19 public health emergency, but who have spent some portion of their compensated time (but less than sixty percent (60%)) mitigating the spread of or responding to the COVID-19 Public Health Emergency. The Municipality may submit, and the County Board will

consider, reimbursing payroll in the amount of the proportion of the individual employees' time spent mitigating the spread of or responding to the COVID-19 public health emergency. For example, if an employee spent twenty percent (20%) of his or her compensated time mitigating the spread of or responding to the COVID-19 public health emergency, the municipality may submit for reimbursement of twenty percent (20%) of the employees' salary during the period of time in which the employee was engaging in COVID-19 related responses.

5.2 Municipality shall not be entitled to reimbursement of expenses for which it has received reimbursement from another County, State, or federal program designed to reimburse local government for costs associated with the coronavirus emergency or other emergencies. If Municipality receives reimbursement from any program referenced above, Municipality shall refund any duplicate reimbursement to the County.

5.3 Under this program, Municipality shall receive, in aggregate, no more than fifty-one dollars and eighty-four cents (\$51.84) for each resident of the Municipality who resides within the geographic boundaries of DuPage County as set forth in Schedule 1 attached to this Agreement. This section shall not bar future additional expenditures by County for specific municipalities which may be disproportionately impacted by COVID-19 and which, in the County's sole opinion, require additional resources to respond to the COVID-19 public health emergency.

5.4 Where Municipality is located, in part, in DuPage County and in part, in other Counties, Municipality should pro-rate their requested expense reimbursements based upon the population of their residents which reside within DuPage County. For Example, if Municipality has sixty percent (60%) of its population in DuPage County, a municipality may seek reimbursement for sixty percent (60%) of the total cost of the expense eligible for reimbursement. Municipality shall not pro-rate expenses which were used only to the benefit of DuPage County residents.

6.0 Cooperation

- 6.1 The County shall assist Municipality in complying with the requirements of the CARES Act and the United States Department of Treasury guidelines by preparing sample forms and providing feedback and guidance with regards to the type and quality of information required to complete such forms.
- 6.2 Municipality agrees to abide by the terms of the CARES Act and all United States Department of Treasury guidelines.
- 6.3 Municipality shall, at the County's request, supply County with all relevant information for the County to evaluate whether a request for reimbursement meets the criteria under the CARES Act and United States Department of Treasury guidelines.

7.0 Records

- 7.1 Municipality shall maintain all records relating to the expenses which Municipality seeks to have reimbursed by County from CARES Act funds for a period of at least ten (10) years or the period of time required by other state or federal law, whichever is longer.
- 7.2 At any time, DuPage County, the DuPage County Finance Department, or the DuPage County Auditor, may request that the Municipality provide records relating to the expenses which Municipality seeks to have reimbursed. Municipality agrees to provide records in response to such requests.
- 7.3 Failure to provide records may result in the denial of the reimbursement request. In circumstances where the reimbursement request has been granted and the records are needed to justify the reimbursement to the Office of the Inspector General or any other office, official, or department which may later become responsible for auditing disbursements of CARES Act funds, failure by Municipality to provide these records, for any reason including the prior destruction of these records, shall constitute a breach of this Agreement. The sole and exclusive remedy for such a breach is that Municipality shall be responsible for repayment of any disbursement which the Office of Inspector General, or its successor, finds improper, unsupported, or unable to be verified. Additionally, Municipality agrees to indemnify the County or make the County whole for any penalty assessed against the County

based upon Municipality's failure to retain or provide records.

8.0 Timeliness.

8.1 The Parties agree that time is of the essence in the processing of applications for reimbursement. The County shall use all reasonable speed and diligence in the processing of applications for reimbursement.

8.2 The Parties agree that time is of the essence in communications seeking supporting documents or requesting records under this agreement. The Parties agree that they shall use all reasonable speed and diligence in responding to requests for records or supporting documents.

9.0 Indemnity.

9.1 The Parties agree that where the County relied upon the certification of the Municipality that such expenses which Municipality sought to have reimbursed from CARES Act funds met the minimum requirements of the CARES Act, and where the Office of the Inspector General, or any other person, official, or department which is charged with the auditing and review of expenditures of CARES Act funds determines that such reimbursement was not permitted under the CARES Act, Municipality agrees to indemnify, reimburse and make whole the County for any funds which the United States Government or its agencies seeks to recoup or collect, either by litigation, or by withholding other federal funds owed to the County. Municipality further agrees to indemnify, reimburse, or make whole the County for any penalties associated with the federal government seeking to recoup the expended CARES Act funds which the County disbursed to Municipality including interest, or any penalty provided by law.

9.2 Municipality agrees to hold County harmless for any evaluation or advice which the County provided to Municipality as to whether the requested reimbursement is a permissible use of the CARES Act funds.

10.0 Term and termination

10.1 Term. This Agreement shall remain in effect until either party provides written notice of termination to the other. Such notice shall be effective 14 days after receipt of the termination.

10.2 Survival of Terms. Those terms relating to the party's obligation to maintain records and provide records, and the Municipality's indemnification of the County shall survive the termination of this Agreement.

11.0 Amendment

11.1 Amendments to this Agreement may be performed with the written consent of the DuPage County Board and Municipal governing board.

12.0 Notices and duplicate copies.

12.1 Written notices required pursuant to this Agreement and all other correspondence between the parties shall be directed to the following and shall be deemed received when hand-delivered or three (3) days after being sent by certified mail, return receipt requested or electronic mail:

DuPage County: Daniel J. Cronin,
DuPage County Board Chairman
421 N. County Farm Road
Wheaton, IL 60187

With a copy to:

DuPage County State's Attorney's Office
ATTN: ASA CONOR MCCARTHY
503 N. County Farm Road
Wheaton, IL 60187

Municipality: City of Darien

With Copies to: [ADDITIONAL RECIPIENT]

12.2 The Parties agree that this agreement may be entered into using identical counterparts, each of which when executed and delivered to the other party shall constitute

a duplicate original, but all counterparts together shall constitute a single agreement. Upon ratification by the governing board of the respective parties, the parties shall each transmit the signed counterparts of this agreement to the other using the recipients listed above in Section 12.1 of this Agreement. This agreement shall go into effect immediately upon the ratification of the last party to execute this agreement.

[Signature Page to Follow]

[THIS SPACE INTENTIONALLY LEFT BLANK]

IN WITNESS WHEREOF, the parties hereto have executed this Agreement, using duplicate counterparts, on the dates listed below.

COUNTY OF DUPAGE:

City of Darien:

Daniel J. Cronin
DuPage County Board Chairman

[Name]
Mayor, [Municipality]

Attest: _____

Attest: _____

Jean Kaczmarek
DuPage County Clerk

Village Clerk Name
Village Clerk

Date: _____

Date: _____

AGENDA MEMO

City Council

July 20, 2020

ISSUE STATEMENT

A motion to direct Staff to proceed with a Landscape Enhancement Project and Easement Agreement for the northwest corner at 7532 Cass Avenue, PIN# 09-28-402-025.

BACKGROUND/HISTORY

As part of an enhancement to the Center of Town City Staff was directed to render drawings for a landscape feature at the northwest corner of Cass Avenue and Plainfield Road. The landscape enhancement includes designs with and without a pond less water feature. The water feature would run 365 days a year.

The landscape enhancement would further incorporate two signs for the business. The signs will meet the City code and will not require a variation(s). All sign costs will be the responsibility of 7532 Cass Avenue LLC. Mr. Manos has approved the terms of the agreement. [Attachment 1](#) is three (3) options of the concept drawings for the proposed design. The Options are further described and cost estimates are as follows:

1. Straight sign with water feature on both sides of the sign-\$20,000
2. V shaped sign with no water feature-\$27,000
3. V shaped sign with water feature-\$37,000

Please note all options include silver lettering CITY OF DARIEN to be placed on the wall.

Staff is recommending Option 3 at a cost not to exceed \$42,000 and includes a \$5,000 contingency for adjustments that may be required due to sight configurations, specifically due to field elevations and grades. The landscape enhancement costs would be shared with 7532 Cass Avenue LLC at a 50/50 cost share, at a cost not to exceed \$42,000. The City's share would be \$21,000 and 7532 Cass Avenue LLC would be responsible for the remaining \$21,000. Regardless of the option that is chosen, all options would include a \$5,000 contingency.

Brick retaining wall that would best match the colors of the clock tower wall

Various plantings variations

*Waterless pond water feature designed to run 365 days a year

Landscape Lighting

*The site has an existing water service that would be utilized for the water feature and Staff would assist with the configuration as required. Having the water on site provides a \$5,000 savings from installation and slightly less to have the service terminated from the water main. The City would be responsible for all costs related to the water usage.

Electric service will be required for the pump, lighting, and signage. The costs associated for the construction of the electric service and utility costs will be the responsibility of the 7532 Cass Avenue LLC. It is estimated that the energy costs for the water feature and landscape lighting will be approximately \$1,500 per year.

An annual landscape maintenance agreement will be required and has been estimated to cost approximately \$3,000 - \$4,000 per year. It is recommended that the actual costs be shared at a 50/50 proportion. The City will incorporate the landscape maintenance into the existing landscape maintenance currently in place.

The work will be completed through 7532 Cass Avenue LLC and the City will reimburse 7532 Cass Avenue LLC on actual costs and lien waivers. The work is required to meet the prevailing wage act.

The Easement Agreement encapsulates the following:

Creates an easement area which allows the City to maintain, the landscape enhancement and authorizes recordation of the corresponding Plat of Easement

An easement agreement between the City and the property owner, 7532 Cass Avenue LLC will be forthcoming, pending landscape option. A Plat of Easement will be prepared and will be recorded with the County of DuPage upon approval of the Easement Agreement.

STAFF RECOMMENDATION

A motion to direct Staff to proceed with a Landscape Enhancement Project and Easement Agreement for the northwest corner at 7532 Cass Avenue, PIN# 09-28-402-025.

Upon final direction Staff will prepare the following for the August 3, City Council Meeting

Resolution authorizing the landscape enhancement
Ordinance for Plat of Easement and Easement Agreement

COMMITTEE RECOMMENDATION

This item has not been forwarded to a Committee.

ALTERNATE CONSIDERATION

As directed by the City Council.

DECISION MODE

This item will be placed on the July 20, 2020 City Council New Business agenda for formal consideration.



OPTION:

1

SCALE: 1/4" = 1'-0"

3 DWF GLOBE
BLUE SPRUCE

8 FALL ASTERS

11 RED SPIREA

3 KARL FORESTER
GRASSES

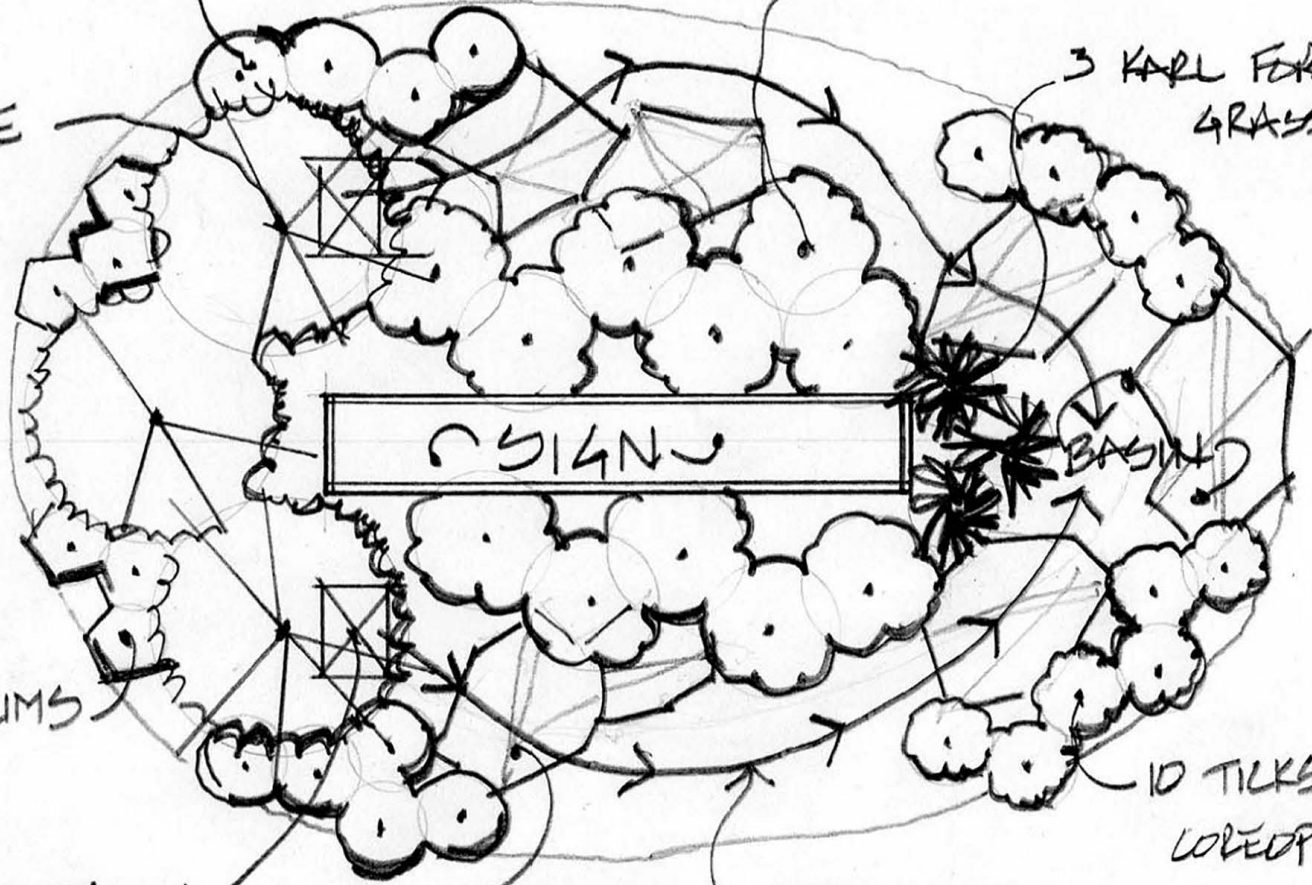

6 PINK
GERANIUMS

2 BIG FALLS

10 TICKSEED
COREOPSIS

WATER FLOW

DISCLOPPING
STONE

BASIN?

SIGN

OPTION

2

SCALE: 1/8" = 1'-0"

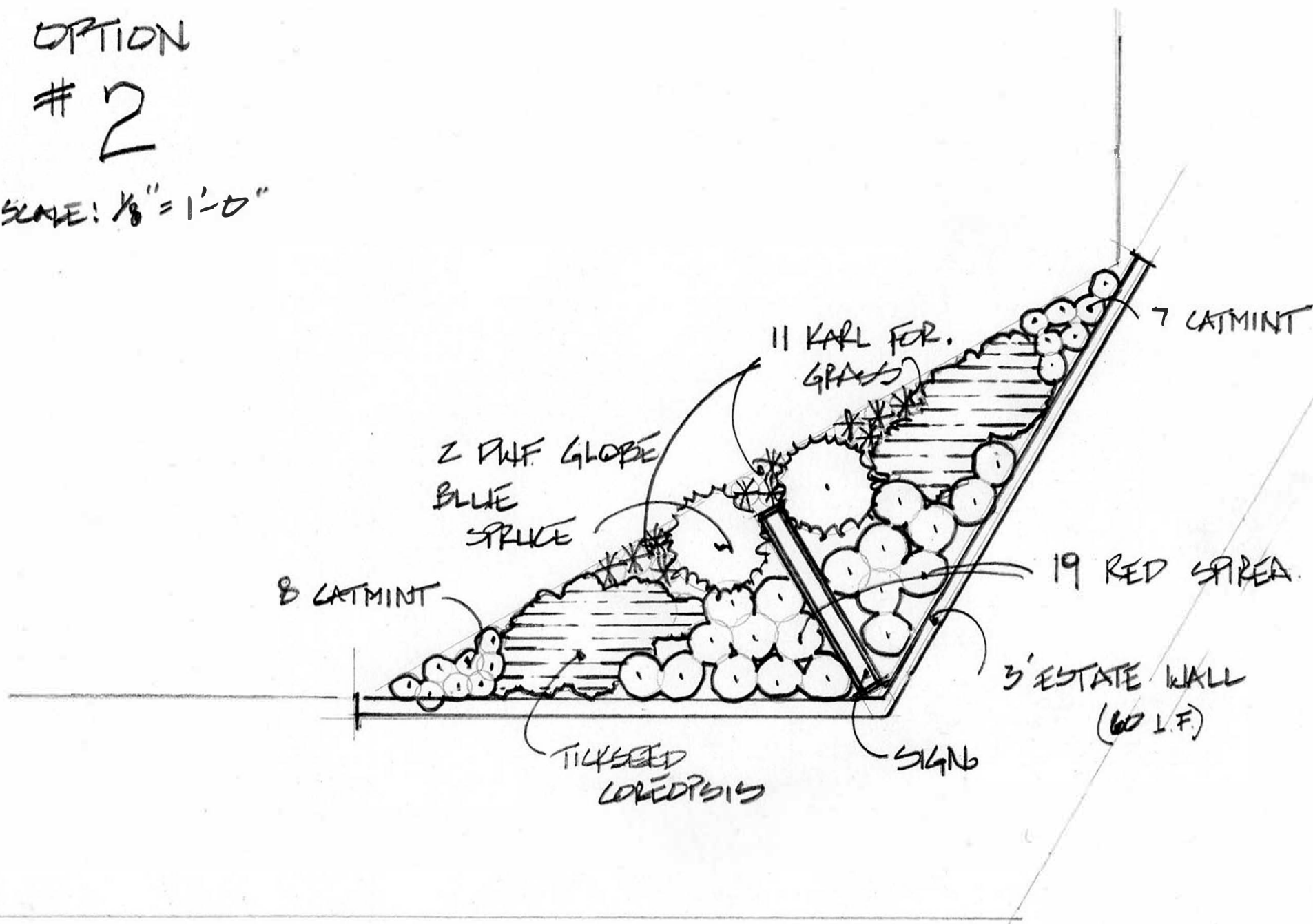

OPTION

#3

SCALE: $\frac{1}{8}'' = 1'-0''$

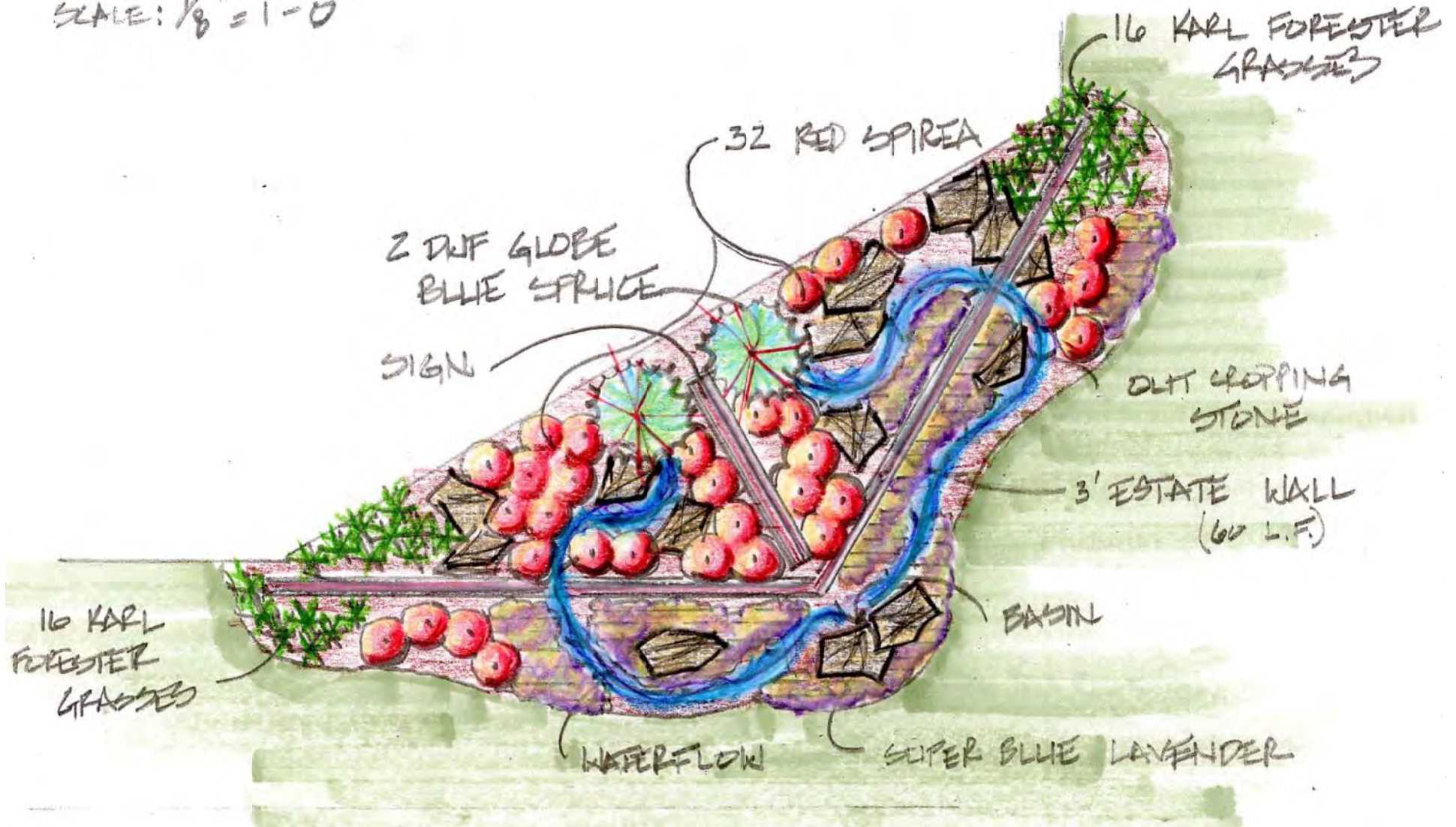

CITY OF DARIEN

RULES FOR COMPLIANCE WITH PUBLIC COMMENT REQUIREMENTS OF THE ILLINOIS OPEN MEETINGS ACT

I. PURPOSE OF RULES.

The purpose of these Rules is to comply with the requirement of Section 2.06 of the Illinois Open Meetings Act that a public comment section be provided at each meeting subject to the Open Meetings Act.

II. DEFINITION OF “PUBLIC BODY” or “BODY.”

For purposes of these Rules, the term “Public Body” or “Body” shall mean the City Council, any Committee of the City Council, and any Board and Commission established by the City Council.

III. RULES GOVERNING PUBLIC COMMENT.

A. Unless otherwise allowed by a majority vote of the Body, the public comment periods shall be as follows:

1. For the City Council, as set forth on the attached **Agenda template**.
2. For Council committees and advisory committees, at the conclusion of the meeting immediately before adjournment. At the direction of the Body, the floor may be opened for public comment in conjunction with specific agenda items.

B. Individuals seeking to make public comment to the Body shall be formally recognized by the Chair.

C. Individuals addressing the Body shall identify themselves by name, but need not provide their home address.

D. Individuals addressing the Body shall do so by addressing their comments to the Body

itself and shall not turn to address the audience.

E. Public comment time shall be limited to three (3) minutes per person.

F. An individual will be allowed a second opportunity to address the Body only after all other interested persons have addressed the Body and only upon the majority vote of the Body.

G. In the case of a special meeting, public comment will be limited to subject matters germane to the agenda of the special meeting.

IV. PUBLIC HEARING REQUIREMENTS.

Additional public comments periods will be allowed as required by law in the case of public hearing, subject to the same time constraints.

Approved by a Motion on November 17, 2014