

AGENDA
Municipal Services Committee
Rescheduled Meeting
April 27, 2016
7:15pm

1. **Call to Order & Roll Call**
2. **Establishment of Quorum**
3. **New Business**
 - a. **Resolution** – Approval of a resolution authorizing the purchase of a Hotsy Hot Pressure Washer Unit from Great Lakes Hotsy in an amount not to exceed \$7,900.00
 - b. **Resolution** – Approval of a resolution accepting a proposal from Tri-Angle Fabrication and Body for the purchase of two (2) Henke 43R11JP, SSTE-11 foot Reversible Plows in an amount not to exceed \$18,564
 - c. **Resolution** – Approval of a resolution authorizing the purchase of one new Vermeer BC1800XL Brush Chipper from Vermeer Midwest in an amount not to exceed \$70,965.00
 - d. **Resolution** – Approval of a resolution authorizing the purchase of one new 2016 Caterpillar Loader Model No 926M Small Wheel Loader from Patten Cat in amount not to exceed \$147,500
 - e. **Resolution** – Approval of a resolution accepting a proposal from Decker Supply Company, Inc. for the purchase of Telespar Sign Posts, Anchors and Rain Caps in an amount not to exceed \$5,963.36
 - f. **Resolution** – Approval of a resolution authorizing the purchase of one new 2016 Hydraulic Hammer-WT Hamr Work Tool attachment from Patten Cat in an amount not to exceed \$23,780.00
 - g. **Resolution** – Approval of a resolution executing a contract with Denler Inc. in amount not to exceed \$183,750 for the 2016 Crack Fill Program.
 - h. **Resolution** – Approval of a resolution authorizing the purchase of one new Factory Cat 24-inch scrubber/sweeper from Factory Cleaning Equipment in an amount not to exceed \$6,600.00
 - i. **Resolution** – Approval of a resolution authorizing the purchase of one new EnviroSight Quickview Air HD Pipeline Camera X8500 from Standard Equipment in an amount not to exceed \$15,000
 - j. **Resolution** – Approval of a resolution authorizing the purchase of one new RD8100 PXL Series Precision Location System Package – Water Main Locator from Associated Technical Services in an amount not to exceed \$7,868
 - k. **Resolution** – Approval of a resolution authorizing the purchase from JX Enterprises, Inc. for the purchase of one new 2017 Peterbilt Model 348 with dump

body and snow plow/de-icing equipment package in an amount not to exceed \$174,910

- l.** **Resolution** – Approval of a resolution authorizing the purchase of one new 2016 Ford Expedition Carryall Unit from Roesch Ford in an amount not to exceed \$35,474
 - m.** **Resolution** – Approval of a resolution authorizing the purchase of one New Holland Workmaster 37 Tractor from Martin Implements in an amount not to exceed \$17,676
 - n.** **Resolution** – Approval of a resolution authorizing the purchase of a Land Pride 16 Series Grooming Mower attachment from Land Pride in an amount not to exceed \$2,473.50
 - o.** **Resolution** – Illinois Department of Transportation authorizing the expenditure of Motor Fuel Tax Funds
 - p.** **Resolution** – Approval of a resolution to accept a proposal from Accurate Tank for the Decommissioning of the Stage 2 Vapor Recovery System, cleaning and televising of the fuel tanks at the Public Works Facility, 1041 S Frontage Road in an amount not to exceed \$11,040
 - q.** **Resolution** – Approval of a resolution authorizing the purchase of 620 5/8 x 3/4 inch water meters and remote readers from HD Supply in an amount not to exceed \$77,500
 - r.** **Resolution** – Approval of a resolution accept a proposal from HBK Water Meters for the service of flow bench testing the replaced meters in an amount not to exceed \$12,400
 - s.** **Resolution** – Approval of a resolution authorizing the purchase, installation, and wiring of 5 street lights for the Portsmouth Drive Street Light Improvement Project with Rags Electric in an amount not to exceed \$29,440; *and* a **Motion** authorizing the removal, disposal, and landscape restoration materials and services for the Portsmouth Drive Street Light Project in an amount not to exceed \$6,194.00
 - t.** **Liquor Code Amendment** to the Liquor Code to change the hours liquor can be served for a Class N Liquor License
 - u.** **Minutes** – March 28, 2016 Municipal Services Committee
- 4.** **Director’s Report**
 - 5.** **Next scheduled meeting – May 23, 2016**
 - 6.** **Adjournment**

AGENDA MEMO
Municipal Services Committee
April 25, 2016

Issue Statement

Approval of a resolution authorizing the purchase of a Hotsy Hot Water Pressure Washer Unit from Great Lakes Hotsy in the amount of \$7,900.00.

Background/History

The FY 16/17 Budget approved funds to replace a wall mount pressure washer. The current model has been in use since 2007. The City Mechanic and staff have determined that the proposed equipment has served its useful life and requires replacement. The proposed pressure washer would be utilized to maintain the City's truck fleet. The cleaning equipment is a necessity to remove the salt and grime from the vehicles after snow events as well as the construction grime from various year round activities including water main breaks. The 2007 pressure washer would be declared surplus property and brought forward under a future agenda memo.

Below please find the results of three competitive quotes for the Pressure Washer. Pricing included the base unit, an under carriage wash and installation.

VENDOR	COST
*Easy Klean	\$ 7,764.00
<i>Great Lakes Hotsy</i>	\$ 7,900.00
Lorchem Technologies	\$ 8,099.00

*Easy Clean is unable to install unit.

The proposed item would be expended from the following accounts:

ACCOUNT NUMBER	ACCOUNT DESCRIPTION	FY 16-17 BUDGET	PROPOSED EXPENDITURE
01-30-4815	Equipment	\$4,250.00	\$ 3,954.50
02-50-4225	Equipment	\$4,250.00	\$ 3,954.50

Staff Recommendation

Staff requests approval of this resolution authorizing the purchase of a Hotsy Hot Water Pressure Washer from Great Lakes Hotsy in the amount of \$7,900.00.

Alternate Consideration

Not approving this item at this time.

Decision Mode

This item will be on the May 2, 2016 City Council agenda for formal consideration.

RESOLUTION NO. _____

A RESOLUTION AUTHORIZING THE MAYOR AND CITY CLERK TO ACCEPT A PROPOSAL FOR THE PURCHASE OF A HOTSY HOT WATER PRESSURE WASHER UNIT FROM GREAT LAKES HOTSY IN AN AMOUNT NOT TO EXCEED \$7,900.

BE IT RESOLVED BY THE CITY COUNCIL OF THE CITY OF DARIEN, DU PAGE COUNTY, ILLINOIS, as follows:

SECTION 1: The City Council of the City of Darien hereby authorizes the Mayor and City Clerk to accept a proposal for the purchase of a Hotsy Hot Water Pressure Washer Unit from Great Lakes Hotsy in an amount not to exceed \$7,900.00, a copy of which is attached hereto as "**Exhibit A**".

SECTION 2: This Resolution shall be in full force and effect from and after its passage and approval as provided by law.

PASSED BY THE CITY COUNCIL OF THE CITY OF DARIEN, DU PAGE COUNTY, ILLINOIS, this 2nd day of May, 2016.

AYES: _____

NAYS: _____

ABSENT: _____

APPROVED BY THE MAYOR OF THE CITY OF DARIEN, DU PAGE COUNTY, ILLINOIS, this 2nd day of May, 2016.

KATHLEEN MOESLE WEAVER, MAYOR

ATTEST:

JOANNE E. RAGONA, CITY CLERK

APPROVED AS TO FORM

CITY ATTORNEY

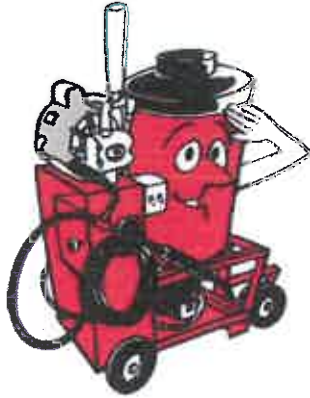

GREAT LAKES HOTSY
 2601 Bernice Rd.
 Lansing, IL 60438
 Phone: (708) 474-9660
 Fax: (708) 474-9930
 greatlakeshotsy@hotmail.com
 www.greatlakeshotsy.com



QUOTATION

Prepared For:
 David Fell
 City of Darien
 1041 S Frontage Road
 Darien, IL 60561
 P: 630.353.8105
 F: 630.887.0091
 dfell@darienil.gov

4.7.16
 Hotsy Sales Consultant: Brian Van Baren
 (708) 474-9660
 brian@greatlakeshotsy.com

QUOTE DOES NOT INCLUDE SALES TAX

Qty	Part Number	Description	Price	Extension
1	1453N	Hotsy Hot Water Pressure Washer 4.0 GPM @ 3,000 PSI, 7.5 H.P 1725 RPM 230 Volt, 1 Phase, 34 Amps, Belt Driven Hotsy Triplex Ceramic Pump, 50' High Pressure Hose, Trigger Gun Control, Nat. Gas Fired, Stationary, Shipping Weight 580 lbs.		\$8,095.00
		<i>Less Sales Discount</i>		<i>(\$2,200.00)</i>
	***	Recommended Accessories	***	
1	MISC	Installation Estimate Removal of old Corty Pressure Washer and Installation of new Hotsy 1453N (includes flexing in utilities and matching up old ventilation with new machine)		\$610.00
1	80.613	Mosmatic Hurricane Pro Undercarriage Washer		\$1,395.00
			Sub-Total	\$7,900.00
			Shipping & Handling	No Charge
			Taxes	\$0.00
			TOTAL	\$7,900.00

Lease Option

	/Month
	/Months

Terms & Conditions: All orders are subject to approval and acceptance by said Hotsy dealer and shall be subject to the terms and conditions herein contained, and to no others whatsoever unless altered or modified by said Hotsy dealer in writing. Said Hotsy dealer shall be excused for any delay due to strikes, accidents, war, fires, Acts of God, or any other causes beyond our control. Promises of delivery are based on our expectations, and does not guarantee to accomplish shipment on the dates or estimated time period mentioned. Orders cannot be canceled, specifications changed, or good returned without written permission. Goods permitted to be returned are subject to restocking and freight charges.

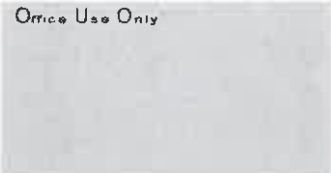

Nothing Cleans Like a Hotsy!

THANK YOU FOR THE OPPORTUNITY TO EARN YOUR BUSINESS

Hotsy



900/1400 Series

#1 in North America for High-Pressure Cleaning Equipment

Hot-Water Pressure Washers

Electric / Belt Drive



Upright, vertical coil delivers high efficiency and maintains constant temperature using Natural Gas or LP Gas.

Industry-standard flue outlet for quick installation

Programmable Smart Control Automation for auto start/stop and time delay shutdown

Pressure relief valve protects the machine and user from thermal expansion

Concealed but accessible Thermostat reduces random user adjustments

Auto-tensioning system maintains belt tension on the pump

Locking lid prevents accidental removal of both panels around the belt and pulley

Adjustable upstream detergent injection ensures high-pressure sudsing for better cleaning

Remote ready for operation in wash bays



Hotsy-designed Triplex pumps carry a 7-year limited warranty

Same footprint as previous generation for easy upgradability

Sleek side and front removeable panels provide easy access to the entire washer for service & maintenance

50-ft. length of high-pressure hose for easy cleaning in a large working area

FEATURES

- 4.0 - 5.0 GPM @ 2000 to 3000 PSI
- NG Fired or LP Fired
- 208V or 230V, 1PH; 208V, 230V, 460V or 575V, 3PH
- ETL-Certified to UL-1776 safety standards

Float tank (with upgraded Hudson valve, standard) helps maintain constant water pressure and flow while helping to prevent sediment from entering the machine's components

Insulated Hotsy trigger gun and insulated wand with ergonomic, adjustable side handle

www.Hotsy.com

Nothing Cleans Like a Hotsy!

Loaded with Innovation and Geared for



- **Innovation** – includes both auto start/stop and time delay shutdown capability as standard features.
- **Safety** – Pressure relief valve and locking lid/panels around the belt and pulleys to keep users safe.
- **Customization** – Concealed thermostat, adjustable detergent injector and programmable shutdown settings let you meet your individual needs.
- **Upgraded features** – Improved belt tensioning system, expandable Smart Relay and upgraded float valve standard.
- **Convenience** – upgrading and servicing are uncomplicated with improved accessibility, easily removed panels and it has the same footprint as the previous generation.



Redesigned With More Features

The Hotsy 900 and 1400 Series pressure washers have long been the core of the Hotsy stationary pressure washer line-up. Now completely redesigned with more standard features, their appeal is even greater to industry professionals.

Taking on heavy industrial cleaning jobs is no problem for these models, which are built with Hotsy ruggedness throughout. The core components of the new 900/1400 Series washers (heating coil, pump and electronics) are protected beneath removable panels, which helps protect from overspray, dust and dirt.

The footprint of the new 900/1400 Series is the same as previous generations, which means users with an older model can upgrade easily without worrying if it will fit. The control panel conceals the programmable smart control interface which allows for setting automatic start and stop with the pull of the trigger gun, as well as time delay and thermal shut down. These features help protect the machine from damage if left unattended.

Models are ideal for heavy-duty cleaning in farming, construction, transportation, automotive, manufacturing as well as any business washing a fleet of vehicles or heavy equipment.



Identical footprint allows for older 900/1400 models like this one to be easily upgraded

Spend time with your local Hotsy Expert

Hotsy has more than 160 local distributors in North America, all factory-trained to properly evaluate your high-pressure cleaning needs. They will perform a site visit to your location to evaluate your cleaning requirements. Hotsy's seasoned network of local application and installation service professionals will ensure you get the safest, most effective and most efficient cleaning solution for your cleaning needs.



Learn more about the services you'll find at your local Hotsy dealer by watching our video



Increased Production with Safety in Mind.

Features

Programmable Smart Control Automation provides complete control over the machine's run time, auto start/stop and time delay shut down functionality.



Detachable panel allows access to wiring and control panel hub.



Vertical spring-tensioned belt provides extended life and reduced maintenance costs by eliminating multiple belts that stretch at different rates. Belt tensioner provides constant tension and makes servicing and maintenance of the belt a breeze.



Large frame Hotsy belt-drive pump features NESTechnology with U-Seals for 3 times longer pump life. The pump also has an oil drain, allowing for easy oil changes.

Total System Solution

The new 900/1400 stationary pressure washers are one component in the total system solution that Hotsy offers. Cleaning systems consist of a pressure washer connected to water, a power source and fuel supply, which pushes the water through a trolley system suspended above, allowing for easy cleaning around a vehicle.

Your Hotsy dealers will work with you to design a custom wash bay system to meet your needs, depending on your space and what you are washing. Drive through bays or washing outdoors on a covered pad are options.

Cost-Effective and Better Cleaning

The 900/1400 models are equipped with an adjustable upstream detergent injector that provides detergent where you're washing. In a washing system, Hotsy detergent can be stored in a drum or tote under or near the pressure washer. Utilizing a detergent proportioner, concentrated detergent is automatically mixed at a pre-determined ratio to be run through the pressure washer. This optimizes cleaning while reducing detergent use and cost. Finally, optional water recycling equipment (like Water Maze™ wash water recycle systems) can be integrated into the system to treat wash water for sewer discharge or reuse.



Learn more about system installations - scan to watch our Wash Bay video



900 / 1400 SERIES Hot-Water ELECTRIC Models

■ NG-Fired or LP-Fired ■ 4.0 to 5.0 GPM @ 2000 to 3000 PSI ■ Hotsy Triplex Pump with 7-yr warranty ■ ETL-Certified for safety

Stationary pressure washers for heavy-duty cleaning.

SPECIFICATIONS											BELT DRIVE
MODEL	GPM	PSI	HP	MOTOR RPM	VOLT/PH	AMP	FUEL	WT/LBS	PUMP MODEL	HOSE	SHIP WT
921N	4.0	2300	6.2	3450	208/1	28	NG	364,835	HHCS06R.1	50'	700
926N	4.0	2000	5	1800	575/3	7	NG	364,835	HHCS06R.1	50'	660
942P	4.0	2000	5	1725	208/3	18	LP	360,997	HH406R.1	50'	590
942N	4.0	2000	5	1725	208/3	18	NG	364,835	HH406R.1	50'	655
943P	4.0	2000	5	1725	230/1	25	LP	360,997	HH406R.1	50'	685
943N	4.0	2000	5	1725	230/1	25	NG	364,835	HH406R.1	50'	685
944P	4.0	2000	5	1725	230/3	16	LP	360,997	HH406R.1	50'	580
944N	4.0	2000	5	1725	230/3	16	NG	364,835	HH406R.1	50'	680
945P	4.0	2000	5	1725	460/3	8	LP	360,997	HH406R.1	50'	585
945N	4.0	2000	5	1725	460/3	8	NG	364,835	HH406R.1	50'	585
1451N	4.0	3000	8.2	3450	208/1	42	NG	364,835	HHCS06R.2	50'	730
1452P	4.0	3000	7.5	1725	208/3	24	LP	360,997	HH406R.2	50'	625
1452N	4.0	3000	7.5	1725	208/3	24	NG	364,835	HH406R.2	50'	625
1453P	4.0	3000	7.5	1725	230/1	34	LP	360,997	HH406R.2	50'	735
1453N	4.0	3000	7.5	1725	230/1	34	NG	364,835	HH406R.2	50'	735
1454P	4.0	3000	7.5	1725	230/3	24	LP	360,997	HH406R.2	50'	625
1454N	4.0	3000	7.5	1725	230/3	24	NG	364,835	HH406R.2	50'	700
1455P	4.0	3000	7.5	1725	460/3	12	LP	360,997	HH406R.2	50'	630
1455N	4.0	3000	7.5	1725	460/3	12	NG	364,835	HH406R.2	50'	780
1456N	4.0	3000	8.2	3450	575/3	10	NG	364,835	HHCS06R.2	50'	621
1473P	5.0	3000	10	1725	230/1	42	LP	378,617	HH406R.2	50'	735
1473N	5.0	3000	10	1725	230/1	42	NG	390,025	HH406R.2	50'	735
1474P	5.0	3000	10	1770	230/3	29	LP	378,617	HH406R.2	50'	740
1474N	5.0	3000	10	1770	230/3	29	NG	390,025	HH406R.2	50'	740

Dimensions: 47.5"l x 21"w x 51"h (including connectors and flue outlet)

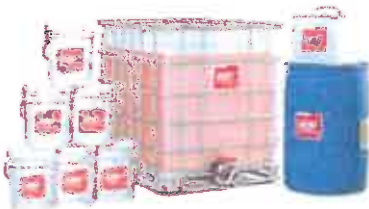

Clean better with Hotsy detergents

Hotsy pressure washers clean best when matched with specially-formulated Hotsy detergents. Nearly all 40 Hotsy detergent formulations contain

Hotsy's exclusive advanced-formula HCC additives to help prevent scale build-up and fight corrosion in your equipment. All Hotsy detergents are highly concentrated, so a little goes a long way.

Distributed by:



Tel: (800) 525-1976 Fax: (888) 880-9631
 www.Hotsy.com email: info@Hotsy.com
 P/N 9.801-491.0 Effective 1/13 Specifications & product descriptions subject to change without notice. ©2013 Hotsy
 A member of KÄRCHER North America

OPTIONS for 900 / 1400 SERIES

- **Remote Controls:** Controls the start up, shut down and with the optional detergent kit, the application of soap with easy to use low voltage switches.
- **LP Conversion Kit:** Converts natural gas fired machines to LP fired machines.
- **6" Gas-Fired Draft Damper:** prevent backdrafts; keeps cold air out and prevents water from running down vent pipes

Hotsy Accessories customize your application for top performance



Hose reels can be mounted on the wall to keep hose neatly stored and shop areas safe



Heavy-duty high-pressure hoses in lengths up to 150-ft.



High-pressure turbo nozzles for faster cleaning



Telescoping wands extend to 24" to reach high places without scaffolding

NOTE: We are constantly improving and updating our products. Consequently, pictures, features & specifications in this brochure may differ slightly from current models. Flow rates & pressure ratings may vary due to variances allowed by manufacturers of our machine components. We attempt to keep our machine performance within ± 10% of listed specifications.

AGENDA MEMO
Municipal Services Committee
April 25, 2016

ISSUE STATEMENT

Approval of a resolution accepting a proposal from Tri-Angle Fabrication and Body for the purchase of two (2) Henke 43R11JP, SSTE-11 foot Reversible Plows in an amount not to exceed \$18,564.

BACKGROUND/HISTORY

The proposed plows would be replacing two plows, purchased in the early 2000's. The plows are deteriorating through corrosion, showing signs of fatigued steel supports and hydraulic issues. The plows would be utilized with the larger trucks. The existing plows will be declared as surplus and a separate agenda memo will be presented at a later date for City Council approval.

The Henke plows are constructed of compressed plastics and steel which allows the weight of the plow to be reduced compared to the older steel plows. The proposed plows would also have a mailbox cutout which will allow the driver to stay close to the curbs and mailboxes when making their curb cut to clear snow from the streets. The plows will have the necessary hookups to fully accommodate the current setup of the trucks.

Below please find the results of three competitive quotes for the equipment.

VENDOR	COST
Auto Truck	\$ 18,764
Henderson	\$ 22,588
<i>Tri-Angle Fabrication & Body</i>	\$ 18,564

The proposed expenditure would be expended from the following line account:

	ACCOUNT DESCRIPTION	FY 6-17 BUDGET	PROPOSED EXPENDITURE	PROPOSED BALANCE
01-30-4815	CAPITAL PURCHASES SNOW PLOW 101 &106	\$20,000	\$ 18,564	\$ 1,436

STAFF RECOMMENDATION

Staff recommends approval of a resolution accepting a proposal from Tri-Angle Fabrication and Body the purchase of two (2) Henke 43R11JP, SSTE-11 foot Reversible Plows in an amount not to exceed \$18,564.

ALTERNATE DECISION

As recommended by the Committee.

Plows
April 25, 2016
Page 2

DECISION MODE

This item will be on the May 2, 2016 City Council agenda for formal consideration.

RESOLUTION NO. _____

A RESOLUTION AUTHORIZING THE MAYOR AND CITY CLERK TO ACCEPT A PROPOSAL FROM TRI-ANGLE FABRICATION AND BODY FOR THE PURCHASE OF TWO (2) HENKE 43R11JP, SSTE-11 FOOT REVERSIBLE PLOWS IN AN AMOUNT NOT TO EXCEED \$18,564.00

BE IT RESOLVED BY THE CITY COUNCIL OF THE CITY OF DARIEN, DU PAGE COUNTY, ILLINOIS, as follows:

SECTION 1: The City Council of the City of Darien hereby authorizes the Mayor and City Clerk to accept a proposal from Tri-Angle Fabrication and Body for the purchase of two (2) Henke 43R11JP, SSTE-11 foot reversible plows in an amount not to exceed \$18,564.00, a copy of which is attached hereto as "**Exhibit A**".

SECTION 2: This Resolution shall be in full force and effect from and after its passage and approval as provided by law.

PASSED BY THE CITY COUNCIL OF THE CITY OF DARIEN, DU PAGE COUNTY, ILLINOIS, this 2nd day of May, 2016.

AYES: _____

NAYS: _____

ABSENT: _____

APPROVED BY THE MAYOR OF THE CITY OF DARIEN, DU PAGE COUNTY, ILLINOIS, this 2nd day of May, 2016.

KATHLEEN MOESLE WEAVER, MAYOR

ATTEST:

JOANNE E. RAGONA, CITY CLERK

APPROVED AS TO FORM

CITY ATTORNEY

Tri-Angle Fabrication & Body**Quotation**

1344 W 43RD Street
Chicago, IL 60609
773-523-0421

DATE April 7, 2016
Quotation # 3142016
Customer ID

Bill To:
Kris Thom
City of Darien
1041 S Frontage Road
Darien, IL 60561-5404
630-887-0008

Quotation valid until: April 17, 2016
Prepared by: bwise

Comments or special instructions:

Description	AMOUNT
<p>(2) Henke 43R11JP,SSTE -- 11 Foot Reversible Snowplow</p> <ul style="list-style-type: none"> • 43" high @ intake with 3/8" poly, "inverted J" style moldboard • (10) Vertical ribs, notched for water drainage • Mailbox cut • (SSTE) square spring trip-edge • Adjustable tension, torsion trip-edge with full length, 1.875" diameter trip shaft • Mechanical trip stop prevents over-stressing trip springs • Hydraulic power reverse with (2) 3" x 16" x 3" S.A. cylinders • Cushing valve to relieve plow power reversing cylinders • Heavy-duty triangular shaped A-Frame with 3/8" thick upper & lower plates • A-Frame-to-push frame pivot pin is 2.5" diameter • Heavy-duty, tubular steel push frame • 1/2" x 6" carbon cutting edge • (UQH) universal quick plow portion • Rubber shield 11' plow • Rod markers • Jack stand <p>Plow painted satin black except for the 3/8" poly moldboard skin</p>	
TOTAL	\$ 18,564.00

If you have any questions concerning this quotation, call **Brett Wise 872-276-0027, bwise6228@gmail.com**

THANK YOU FOR YOUR BUSINESS!



PROPOSAL

AUTO TRUCK GROUP
1420 BREWSTER CREEK BLVD
EARTLETT, IL 60103
PHONE (630)860-5600 * FAX(630)860-5631
E-MAIL: sales@autotruck.com



1874
Contact: KRIS THROM
CITY OF DARIEN
1041 S FRONTAGE RD

DARIEN, IL 60561-5404

Quote No : 458006
Quote Date : 3/15/2016
Expire Date: 4/14/2016
Sales Rep : 112
Phone No : 630-887-0008
Fax No : 630-887-0091

(1) Henke 43R11JP, SSTE -- 11 Foot Reversible Snowplow W/ MAIL BOX CUT OUT

TOTAL \$ 9,382.00 EACH

0* *

0* *

9,382* X

2* =

18,764* *

0* 0

Submitted By: _____

Accepted By: _____

Date: _____

Make :
Model :
Year :

Wheelbase :
Cab-Axle :
Body Paint:

VIN :
Trans :
Factory Ord:

We put the work in work trucks.

Chicago - Colorado Springs - Denver- Ft. Wayne - Ft. Worth - Kansas City - Louisville - Toronto



Henderson Products
124 Industrial Drive
Gilberts, IL. 60136

Toll Free: 888-360-7483
Office: 847-836-4996
Cell: 815-603-2004

Quote

Date: 3/16/2016
To: Kris Throm
By: Norm LaValla
Re: RSP 11' 42 TE OC P J

Henderson NJPA Contract #080114-HPI
City Darien NJPA #110530

Henderson Truck Equipment-Illinois is pleased to quote the following equipment:

Henderson Products RSP SNOWFOE 11' TE OC
11' Plow Length, 42" moldboard w/Integral shield
Adjustable torsion trip edge, (5) 3/4" square torsion springs
HD outboard cylinder type
Quick Hitch, plow side
3/8" poly moldboard J Style
(3) attack angles 5, 15 or 20 degrees
(6) moldboard to push tube frame pivot points
12" rubber deflector, 36" side markers, Screw adjustable parking jack

Price per Unit:	\$11,294.00
Number of Units	2
Extended Price	\$22,588.00
Tax	
Total Quote Price	\$22,588.00

FOB Gilberts, IL

Please note the following regarding installation quotes:

A clean truck frame without obstruction is assumed in the pricing of our quote. Re-positioning of air tanks, fuel tanks or other obstacles to the ease of installation may require additional charges. Henderson will notify you before modification if this occurs.

AGENDA MEMO
Municipal Services Committee
April 25, 2016

ISSUE STATEMENT

A resolution authorizing the purchase of one new Vermeer BC1800XL Brush Chipper, to be awarded to Vermeer Midwest, in an amount not to exceed \$70,965.00.

BACKGROUND/HISTORY

The proposed request is for one (1) Vermeer BC1800XL Brush Chipper and would be replacing unit 307, 1998 Vermeer BC1800A Brush Chipper. It received a rating of 76.69 during this year's mechanic evaluation.

The equipment is utilized for brush chipping throughout the year and the machine has been experiencing ongoing mechanical issues related to electrical and mechanical. The chipper has exceeded its useful life, which averages twelve years in a municipal setting. Staff has further selected the Vermeer line as the preferred choice as to maintain consistency and familiarity due to the fact that the existing chippers are Vermeer products. Attached and labeled as **Attachment A** is the vehicle rating and repairs to date for Unit 307. The existing machine will be declared as surplus and a separate agenda memo will be presented at a later date for City Council approval.

The Vermeer BC1800XL Brush Chipper exceeds the technology of the earlier versions, especially safety related items. The chipper has the capability of chipping logs up to 19 inch diameter. Please note, costs related to chippers have more than doubled since last purchased primarily due to EPA mandates for Tier 4F Engines.

Staff has selected the Vermeer Corporation to supply the equipment and is the awarded vendor for the National Joint Purchasing Alliance-NJPA Contract Number 070313, for equipment sales to municipalities nationally. Attached and labeled as **Attachment B**, pages 1-4, is information regarding the National Joint Purchasing Alliance and the cost breakdown and specifications for the Vermeer BC1800XL Brush Chipper.

The proposed expenditure would be expended from the following line account:

ACCOUNT NUMBER	ACCOUNT DESCRIPTION	FY16-17 BUDGET	PROPOSED EXPENDITURE	PROPOSED BALANCE
01-30-4815	CAPITAL PURCHASES CHIPPER UNIT 307	\$75,300	\$ 70,965	\$ 4,335

STAFF RECOMMENDATION

Staff recommends approval of the resolution authorizing the purchase of one new Vermeer BC1800XL Brush Chipper, to be awarded to Vermeer Midwest, in an amount not to exceed \$70,965.

Brush Chipper
April 25, 2016
Page 2

ALTERNATE DECISION

As recommended by the Committee.

DECISION MODE

This item will be on the May 2, 2016 City Council agenda for formal consideration.

CRITERIA FOR REPLACING CITY VEHICLES AND EQUIPMENT				
UNIT NO	307	DEPARTMENT	Street	DATE
MODEL YEAR	1998	MODEL	Chipper	4-7-16
CURRENT MILEAGE		CURRENT HOURS	2884	
			MAXIMUM POINTS	VEHICLE SCORE
AGE				
	Department	Street		
	Life Expectancy	12		
	Age as of Report Date	18		
	AGE: Meets Requirements		20	20
USAGE				
	MILES			
	HOURS	2884		
	ATTACHMENT C OF THE VEHICLE REPLACEMENT POLICY			
	USAGE: Meets Requirements		20	7.19
TYPE OF SERVICE				
	1-LIGHT DUTY			
	15-CRITICAL DUTY			
	SERVICE: Meets Requirements		15	15
RELIABILITY				
	RELIABILITY: Frequency or Visits for Service			
	RELIABILITY: Meets Requirements		15	12
MAINTENANCE AND REPAIR COSTS				
	REPAIRS: Cost per Mile/Hours Exceeds Vehicle in Class			
	ORIGINAL PURCHASE PRICE	45,000.00		
	LIFE TO DATE REPAIR COST	5,436.73		
	PERCENTAGE OF REPAIRS TO PURCHASE PRICE	12.08%		

UNIT NO	307	DEPARTMENT	Street	DATE
MODEL YEAR	1998	MODEL	chipper	4-7-16
CURRENT MILEAGE		CURRENT HOURS	2884	
			MAXIMUM POINTS	VEHICLE SCORE
PERCENTAGES OF REPAIR POINTS	POINTS			
1 THROUGH 20	2			
21 THROUGH 40	4			
41 THROUGH 60	6			
61 THROUGH 80	8			
81 THROUGH 100	10			
	REPAIRS: Meets Requirements		10	2
CONDITION				
	CONDITION OF ENGINE COMPONENTS (MAJOR REPAIRS NEEDED OR ANTICIPATED), BODY (BODY SHEET METAL RUSTED, STRUCTURAL COMPONENTS)			
	CONDITION: Meets Requirements		15	15
TECHNOLOGICAL ADVANCEMENTS	FUEL EMISSIONS, SAFETY FEATURES, ERGONOMICS		5	5
TOTAL POINTS			100	76.69

CITY OF DARIEN
 Repair Transaction Cost Detail

Equipment#	Repair Order#	Date	Meter(1)	Shop Loc/ Rep Class	Rep Reason/ Rep Site			
307	0000018884	09/16/98	128	01/01	08/01			
	<u>Group-System</u>			<u>Mech/Vendor</u>	<u>Work Acc</u>	<u>Part(\$)</u>	<u>Labor(\$)</u>	<u>Hours</u>
	01-PMA - PREV. MAINT.			001	A	13.75	28.00	1.00
307	0000018885	11/03/98	171	01/01	08/01			
	01-PMA - PREV. MAINT.			001	A	51.56	14.00	0.50
307	0000018886	11/12/99	375	01/01	08/01			
	01-PMA - PREV. MAINT.			001	A	95.09	56.00	2.00
307	0000023839	07/18/00	475	01/01	08/01			
	01-PMB - PREV. MAINT.			001		0.00	28.00	1.00
307	0000023873	08/02/00	500	01/01	08/01			
	01-PMC - PREV. MAINT.			001		0.00	14.00	0.50
307	0000023922	09/21/00	525	01/01	08/01			
	01-PMA - PREV. MAINT.			001		35.20	28.00	1.00
307	0000023991	11/14/00	553	/01	08/01			
	01-PMC - PREV. MAINT.			002		31.73	7.50	0.50
307	0000024008	11/28/00	560	/01	04/01			
	11-82 - CHIPPERS			001		255.36	28.00	1.00
307	0000024081	02/07/01	600	/01	08/01			
	01-PMC - PREV. MAINT.			002		0.00	7.50	0.50
307	0000024230	06/21/01	600	/01	08/01			
	01-PMA - PREV. MAINT.			001		35.95	28.00	1.00
307	0000024238	06/22/01	1090	/01	08/01			
	01-PMC - PREV. MAINT.			001		0.00	28.00	1.00
307	0000024343	10/04/01	1090	/01	08/01			
	01-PMA - PREV. MAINT.			001		23.42	56.00	2.00
	01-PMB - PREV. MAINT.			001		25.44	0.00	0.00
	01-PMC - PREV. MAINT.			001		0.00	28.00	1.00
307	0000024469	01/09/02	712	/01	08/01			
	01-PMC - PREV. MAINT.			002		0.00	7.50	0.50
307	0000024566	04/02/02	712	/01	08/01			
	01-PMC - PREV. MAINT.			002		0.00	0.00	0.00
307	0000024697	07/15/02	712	01/01	08/01			
	01-PMC - PREV. MAINT.			001		0.00	14.00	0.50
307	0000024706	07/15/02	780	01/01	08/01			
	01-PMA - PREV. MAINT.			001		98.88	28.00	1.00
307	0000024826	10/28/02	844	/01	08/01			
	01-PMC - PREV. MAINT.			002		0.00	7.50	0.50
307	0000024961	02/28/03	844	/01	08/01			
	01-PMC - PREV. MAINT.			001		0.00	14.00	0.50
307	0000025047	04/17/03	844	/01	08/01			
	01-PMC - PREV. MAINT.			002		0.00	7.50	0.50
307	0000025101	06/04/03	889	/03	01/02			
	11-82 - CHIPPERS			001		32.72	0.00	0.00
307	0000025128	06/26/03	889	/02	01/01			
	11-82 - CHIPPERS			001		44.58	14.00	0.50
307	0000025130	06/27/03	902	/03	01/01			

CITY OF DARIEN
 Repair Transaction Cost Detail

Equipment#	Repair Order#	Date	Motor(1)	Shop Loc/ Rep Sizes	Rep Reason/ Rep Site			
	04-11 - AXEL FRONT			001		180.01	112.00	4.00
307	0000025157	07/15/03	921	/01	08/01			
	<u>Group System</u>			<u>Mech/Vendor</u>	<u>Work Acc</u>	<u>Part(\$)</u>	<u>Labor(\$)</u>	<u>Hours</u>
	01-PMA - PREV. MAINT.			001		12.75	28.00	1.00
307	0000025197	08/26/03	930	/01	08/01			
	01-PMA - PREV. MAINT.			001		0.00	14.00	0.50
307	0000025269	10/24/03	1025	/01	08/01			
	01-PMA - PREV. MAINT.			001		14.75	42.00	1.50
	07-46 - BELTS			001		169.05	14.00	0.50
307	0000025284	11/05/03	1045	/01	08/01			
	01-PMB - PREV. MAINT.			001		0.00	14.00	0.50
	01-PMC - PREV. MAINT.			001		0.00	14.00	0.50
307	0000025398	02/24/04	1045	/01	08/01			
	01-PMC - PREV. MAINT.			001		0.00	14.00	0.50
307	0000025529	08/15/04	1100	/01	08/01			
	01-PMC - PREV. MAINT.			001		0.00	14.00	0.50
	11-87 - LAWN MOWERS			001		359.20	14.00	0.50
307	0000025709	11/03/04	1100	01/01	08/01			
	01-PMA - PREV. MAINT.			002		62.85	7.50	0.50
	01-PMC - PREV. MAINT.			002		0.00	7.50	0.50
307	0000025839	02/22/05	1236	01/01	08/01			
	01-PMC - PREV. MAINT.			001		0.00	0.00	0.00
307	0000025840	02/22/05	1236	01/01	08/01			
	01-PMA - PREV. MAINT.			001		0.00	14.00	0.50
307	0000025909	04/18/05	1277	01/01	08/01			
	11-82 - CHIPPERS			001		36.31	14.00	0.50
307	0000025940	05/11/05	1262	/01	08/01			
	01-PMB - PREV. MAINT.			001		3.17	14.00	0.50
307	0000025972	06/17/05	1275	/01	08/01			
	01-PMC - PREV. MAINT.			001		0.00	42.00	1.50
307	0000026001	07/14/05	1294	/02	04/01			
	02-17 - TIRES,TUBES,ETC			002		278.48	30.00	2.00
307	0000026128	10/20/05	1345	/01	08/01			
	01-PMA - PREV. MAINT.			001		34.26	28.00	1.00
	01-PMC - PREV. MAINT.			001		0.00	14.00	0.50
307	0000026314	02/23/06	1371	/01	08/01			
	01-PMC - PREV. MAINT.			002		0.00	7.50	0.50
307	0000026397	04/13/06	1371	/01	08/01			
	06-35 - BATTERY			001		85.11	28.00	1.00
307	0000026601	07/24/06	1468	/01	08/01			
	01-PMA - PREV. MAINT.			001		118.26	28.00	1.00
307	0000026619	08/01/06	1468	/01	08/01			
	01-PMC - PREV. MAINT.			001		0.00	14.00	0.50
307	0000027068	11/09/06	1516	/01	08/01			
	01-PMC - PREV. MAINT.			002		0.00	7.50	0.50
307	0000027206	03/22/07	1516	/01	08/01			

CITY OF DARIEN
 Repair Transaction Cost Detail

Equipment#	Repair Order#	Date	Meter(1)	Shop Loc/ Rep Class	Rep Reason/ Rep Site			
	01-PMC - PREV. MAINT.			001		0.00	14.00	0.50
307	0000027380	07/18/07	1580	/01	08/01			
	<u>Group-System</u>			<u>Mech/Vendor</u>	<u>Work Acc</u>	<u>Part(\$)</u>	<u>Labor(\$)</u>	<u>Hours</u>
	01-PMA - PREV. MAINT.			001		35.54	56.00	2.00
	01-PMC - PREV. MAINT.			001		0.00	28.00	1.00
307	0000027499	10/24/07	1580	/01	08/01			
	01-PMC - PREV. MAINT.			001		0.00	14.00	0.50
307	0000027737	02/28/08	1653	/01	08/01			
	01-PMC - PREV. MAINT.			002		0.00	7.50	0.50
307	0000027948	06/18/08	1701	/01	08/01			
	01-PMC - PREV. MAINT.			002		0.00	7.50	0.50
	01-PMA - PREV. MAINT.			002		35.54	15.00	1.00
307	0000027995	08/08/08	1752	/01	08/01			
	07-42 - COOLING.SYS			001		861.60	56.00	2.00
307	0000028017	08/19/08	1753	/01	08/01			
	01-PMB - PREV. MAINT.			001		39.15	28.00	1.00
307	0000028086	10/16/08	1780	/01	08/01			
	01-PMB - PREV. MAINT.			001		3.42	28.00	1.00
	01-PMC - PREV. MAINT.			001		0.00	28.00	1.00
307	0000028141	11/20/08	1800	/01	08/01			
	01-PMA - PREV. MAINT.			002		64.00	15.00	1.00
	01-PMC - PREV. MAINT.			002		0.00	15.00	1.00
307	0000028287	03/18/09	1802	/01	08/01			
	01-PMC - PREV. MAINT.			002		0.00	7.50	0.50
307	0000028408	08/23/09	1824	/01	08/01			
	05-23 - CLUTCH			002		1,432.99	90.00	6.00
307	0000028439	07/07/09	1850	/01	08/01			
	01-PMA - PREV. MAINT.			002		36.70	7.50	0.50
307	0000028442	07/08/09	1850	/01	08/01			
	01-PMA - PREV. MAINT.			002		34.26	30.00	2.00
	01-PMC - PREV. MAINT.			002		177.60	15.00	1.00
307	0000028607	11/05/09	1925	01/01	08/01			
	01-PMA - PREV. MAINT.			002		36.35	30.00	2.00
	07-41 - AIR INTAKE SYS			002		35.15	3.75	0.25
	01-PMC - PREV. MAINT.			002		0.00	7.50	0.50
307	0000028708	02/03/10	1930	01/01	08/01			
	01-PMB - PREV. MAINT.			002		0.00	7.50	0.50
307	0000028758	03/09/10	1930	01/01	08/01			
	01-PMC - PREV. MAINT.			002		0.00	15.00	1.00
307	0000028903	07/22/10	2011	01/01	08/01			
	01-PMC - PREV. MAINT.			001		0.00	28.00	1.00
307	0000029052	11/11/10	2011	01/01	08/01			
	01-PMA - PREV. MAINT.			002		20.48	30.00	2.00
	01-PMB - PREV. MAINT.			002		15.87	0.00	0.00
	01-PMC - PREV. MAINT.			002		0.00	7.50	0.50
307	0000029167	02/28/11	2103	01/01	08/01			
	01-PMC - PREV. MAINT.			001		0.00	14.00	0.50

CITY OF DARIEN
 Repair Transaction Cost Detail

Equipment#	Repair Order#	Date	Meter(1)	Shop Loc/ Rep Class	Rep Reason/ Rep Site			
307	0000029301	06/15/11	2128	01/01	08/01			
	<u>Group-System</u>			<u>Mech/Vendor</u>	<u>Work Acc</u>	<u>Part(\$)</u>	<u>Labor(\$)</u>	<u>Hours</u>
	01-PMC - PREV. MAINT.			002		0.00	30.00	2.00
307	0000029322	07/07/11	2188	01/01	08/01			
	01-PMA - PREV. MAINT.			002		27.70	15.00	1.00
307	0000029447	10/14/11	2250	01/01	08/01			
	01-PMC - PREV. MAINT.			002		0.00	7.50	0.50
307	0000029679	03/29/12	1863	01/01	08/01			
	01-PMA - PREV. MAINT.			002		35.37	60.00	4.00
	01-PMB - PREV. MAINT.			002		0.00	7.50	0.50
	01-PMC - PREV. MAINT.			002		0.00	7.50	0.50
	07-41 - AIR INTAKE SYS			002		81.10	3.00	0.20
307	0000029687	04/12/12	2277	01/02	08/01			
	01-PMA - PREV. MAINT.			002		35.37	48.00	3.20
	01-PMB - PREV. MAINT.			002		8.85	3.00	0.20
	07-41 - AIR INTAKE SYS			002		79.69	3.00	0.20
307	0000029784	06/18/12	2308	01/01	08/01			
	01-PMA - PREV. MAINT.			002		0.00	3.75	0.25
	01-PMB - PREV. MAINT.			002		0.00	3.75	0.25
	01-PMC - PREV. MAINT.			002		0.00	7.50	0.50
307	0000029787	06/19/12	2308	01/03	01/01			
	02-17 - TIRES,TUBES,ETC			002		452.78	30.00	2.00
307	0000029800	07/03/12	2308	01/03	01/01			
	09-57 - HYDRAULIC SYS			002		91.08	30.00	2.00
307	0000029842	08/02/12	2347	01/03	01/01			
	12-94 - CUTTING EDGES			002		0.00	45.00	3.00
307	0000029876	08/28/12	2351	01/03	01/01			
	07-44 - FUEL SYS			002		0.00	37.50	2.50
307	0000029917	10/12/12	2372	01/01	08/01			
	01-PMC - PREV. MAINT.			002		0.00	7.50	0.50
307	0000030120	04/17/13	2389	01/03	01/01			
	01-PMA - PREV. MAINT.			002		48.94	18.75	1.25
307	0000030130	04/24/13	2404	01/03	01/01			
	06-33 - IGNITION SYS			002		22.24	7.50	0.50
307	0000030249	08/13/13	2507	01/01	08/01			
	11-82 - CHIPPERS			002		477.53	22.50	1.50
	07-41 - AIR INTAKE SYS			002		47.15	3.75	0.25
	01-PMC - PREV. MAINT.			002		0.00	7.50	0.50
307	0000030270	08/14/13	2507	01/03	01/01			
	06-31 - CHARGING SYS			002		250.00	15.00	1.00
307	0000030288	09/16/13	2544	01/03	01/01			
	11-82 - CHIPPERS			002		28.86	7.50	0.50
307	0000030627	08/23/14	2657	01/01	08/01			
	01-PMA - PREV. MAINT.			002		53.34	15.00	1.00
	01-PMC - PREV. MAINT.			002		12.80	18.75	1.25
307	0000030980	08/28/15	2794	01/03	01/01			
	06-35 - BATTERY			002		135.74	22.50	1.50

CITY OF DARIEN
 Repair Transaction Cost Detail

Equipment#	Repair Order#	Date	Meter(1)	Shop Loc/ Rep Class	Rep Reason/ Rep Site			
307	0000035668	09/26/06	1497	/01	08/01			
	<u>Group-System</u>			<u>Mech/Vendor</u>	<u>Work Acc</u>	<u>Part(\$)</u>	<u>Labor(\$)</u>	<u>Hours</u>
	01-PMB - PREV. MAINT.			001		4.07	28.00	1.00
				Grand Total		<u>6,848.94</u>	<u>2,101.00</u>	<u>102.80</u>

2016 Vermeer Corporation
NJPA Landscape Equipment Contract # 070313-VRM

QUOTE
 ORDER



BC1800XL - 19" Brush Chipper with Tier 4F Engine

Basic Unit - 130 HP Cummins (Use this pricing if specifications beyond those shown below are desired)

BC1800XL Brush Chipper (19" capacity drum style) w/ 130 hp Cummins 3.8L Tier 4 Final turbocharged diesel engine, high coolant temperature and low oil pressure automatic shutdown, precleaner, DEF tank, springloaded clutch, live hydraulics, variable speed dual vertical feed rollers, selectable SmartFeed, pintle hitch, lockable battery box, lockable control panel, lockable engine doors, lockable toolbox, infeed curtain, dual-edged knives, selected ECOIdle, Tree Commander remote control system (115); non winch option (131); heavy duty manual jack (139); 10,000 lb. axle w/ torsion suspension and electric brakes, telescoping tongue, 235/75R 17.5 radial tires w/o winch (135); LED lights (155); 6-way round trailer plug (040); right side controls (includes clutch handle and deluxe instrument panel located on right side of machine - deluxe instrument panel includes multifunction display (MFD), fuel gauge and DEF gauge (151); manually operated discharge/chip chute rotation and deflector (015)

For additional options, see "Optional Features" section below.

Basic Unit Price:

Value Package (ESVP) (Receive additional savings by ordering your unit with the most commonly requested specifications)

To receive addl savings, order unit as specified above, "As Is" with NO change to options shown above.

Value Package Price:

Basic Unit - 173 HP John Deere (Use this pricing if specifications beyond those shown below are desired)

BC1800XL Brush Chipper (19" capacity drum style) w/ 173 hp John Deere 4045 Tier 4 Final turbocharged diesel engine, high coolant temperature and low oil pressure automatic shutdown, precleaner, DEF tank, springloaded clutch, live hydraulics, variable speed dual vertical feed rollers, selectable SmartFeed, pintle hitch, lockable battery box, lockable control panel, lockable engine doors, lockable toolbox, infeed curtain, dual-edged knives, selected ECOIdle, Tree Commander remote control system (115); non winch option (131); heavy duty manual jack (139); 10,000 lb. axle w/ torsion suspension and electric brakes, telescoping tongue, 235/75R 17.5 radial tires w/o winch (135); LED lights (155); 6-way round trailer plug (040); right side controls (includes clutch handle and deluxe instrument panel located on right side of machine - deluxe instrument panel includes tachometer w/ LCD screen that can display hours, oil pressure, water temperature and engine error codes) (153); manually operated discharge/chip chute rotation and deflector (015)

For additional options, see "Optional Features" section below.

Basic Unit Price:

Value Package (ESVP) (Receive additional savings by ordering your unit with the most commonly requested specifications)

To receive addl savings, order unit as specified above, "As Is" with NO change to options shown above.

Value Package Price: **\$70,155.00**

To receive "Optional Features" below, add to "Basic Unit" price above to arrive at final pricing. **DO NOT** add to "Value Package" pricing:

- Optional Features:**
- Winch w/ manual right side hydraulic directional controls (093); in lieu of no winch (131) (Must include sales code -133 or -141 below when choosing this option)
 - Heavy duty hydraulic jack (140); in lieu of heavy duty manual jack (139)
 - Hydraulic Brakes w/ fixed tongue (133); in lieu of electric brakes (135)
 - Electric Brakes w/ Winch Option (141); in lieu of non winch option (135)
 - Right side manual tall discharge/chip chute (016)
 - Manual height adjustable discharge chip chute (012)
 - Hydraulic discharge/chip chute (rotate & deflect) (078)
 - Hydraulic tall discharge/chip chute (rotate & deflect) (079)
 - Hyd rotation & manual height adjustable chute (080)
 - Biodegradable Hydraulic Oil (998)
 - Miscellaneous Features: sales code ___
- \$ _____

	Subtotal: <u>\$70,155.00</u>
	Dealer Freight & Prep: <u>\$810.00</u>
	Quantity: <u>1</u>
	Total: <u>\$70,965.00</u>
Enter Sales Tax %:	Sales Tax: <u>TBD</u>
	Grand Total <u>\$70,965.00</u>

Pricing effective 04/01/16
NOTE: All pricing in USD \$
NOTE: Include applicable sales tax
Quotes valid for 30 days

ACCEPTED:
Vermeer
BY: _____
DATE: _____

Customer
BY: _____
DATE: _____

Any applicable sales tax is not included. Prices subject to change without notice. These prices are exclusive of any and all duties, import fees, taxes, or other similar charges. These prices may not be available in any transaction involving a trade or rental transaction. This sheet may not include all possible specifications available for this model. For complete product specifications, please contact your local authorized Vermeer dealer. Unless otherwise noted, dealer freight & prep to be determined.



FORM D

Formal Offering of Proposal
(To be completed Only by Proposer)



GROUNDS MAINTENANCE WITH RELATED EQUIPMENT, ACCESSORIES AND SUPPLIES.

In compliance with the Request for proposal (RFP) for "GROUNDS MAINTENANCE WITH RELATED EQUIPMENT, ACCESSORIES AND SUPPLIES", the undersigned warrants that I/we have examined this RFP and, being familiar with all of the instructions, terms and conditions, general specifications, expectations, technical specifications, service expectations and any special terms, do hereby propose, fully commit and agree to furnish the defined equipment/products and related services in full compliance with all terms, conditions of this RFP, any applicable amendments of this RFP, and all Proposer's Response documentation. Proposer further understands they accept the full responsibility as the sole source of responsibility of the proposed response herein and that the performance of any sub-contractors employed by the Proposer in fulfillment of this proposal is the sole responsibility of the Proposer.

Company Name: Vermeer Corporation Date: 06/24/2013

Company Address: 1210 Vermeer Road East

City: Pella State: IA Zip: 50219

Contact Person: Jerry Beyer Title: Sr. Global Accounts Manager

Authorized Signature (ink only): *Jerry Beyer* Jerry Beyer
(Name printed or typed)



Contract Acceptance and Award

(To be completed only by NJPA)

NJPA 070313 GROUNDS MAINTENANCE WITH RELATED EQUIPMENT, ACCESSORIES AND SUPPLIES

Vermeer Corporation

Proposer's full legal name

Your proposal is hereby accepted and awarded. As an awarded Proposer, you are now bound to provide the defined product/equipment and services contained in your proposal offering according to all terms, conditions, and pricing set forth in this RFP, any amendments to this RFP, your Response, and any exceptions accepted or rejected by NJPA on Form C.

The effective date of the Contract will be September 11, 2013 and continue for four years thereafter AND which is subject to annual renewal at the option of both parties. This contract has the consideration of an optional fifth year renewal option at the discretion NJPA.

National Joint Powers Alliance® (NJPA)

NJPA Authorized signature:

[Signature]
NJPA Executive Director

Chadi Coanette
(Name printed or typed)

Awarded this

20th

day of August 20 13

NJPA Contract Number # 070313 - VPM

NJPA Authorized signature:

[Signature]
NJPA Board Member

Scott Veronen
(Name printed or typed)

Executed this

20th

day of August 20 13

NJPA Contract Number # 070313 - VPM

Proposer hereby accepts contract award including all accepted exceptions and NJPA clarifications identified on FORM C.

Vendor Name Vermeer Corporation

Vendor Authorized signature:

[Signature]

Jerry Beyer

(Name printed or typed)

Title: Sr. Global Accounts Manager

Executed this

20th

day of August 20 13

NJPA Contract Number # 070313 - VPM

ANNUAL RENEWAL OF AGREEMENT

Made by and Between

Vermeer Corporation (Vendor)
1210 Vermeer Road East
Pella, IA 50219

and

National Joint Powers Alliance® (NJPA)
202 12th Street NE
Staples, MN 56479
Phone: (218) 894-1930

Whereas:

"Vendor" and "NJPA" have entered into an "Acceptance and Award #070313-VRM" for the procurement of Grounds Maintenance with Related Equipment, Accessories and Supplies, and having a maturity date of August 20, 2017, and which are subject to annual renewals at the option of both parties.

Now therefore:

"Vendor" and "NJPA" hereby desire and agree to extend and renew the above defined contract for the period of August 20, 2015 to August 20, 2016.

National Joint Powers Alliance® (NJPA)

By:  _____, Its: Executive Director/CEO

Name printed or typed: Chad Coquette

Date: 8/10/15

Vermeer Corporation

By:  _____, Its: Sr. Corporate Accounts Manager

Name printed or typed: Jerry Beyer

Date: 08/05/2015

If you do not desire to extend contract, please sign below and return this agreement.
Discontinue: We desire to discontinue the contract.

Signature: _____ Date: _____

RESOLUTION NO. _____

A RESOLUTION AUTHORIZING THE MAYOR AND CITY CLERK TO ACCEPT A PROPOSAL FROM VERMEER MIDWEST FOR THE PURCHASE OF ONE (1) NEW VERMEER BC1800XL BRUSH CHIPPER IN AN AMOUNT NOT TO EXCEED \$70,965.00

BE IT RESOLVED BY THE CITY COUNCIL OF THE CITY OF DARIEN, DU PAGE COUNTY, ILLINOIS, as follows:

SECTION 1: The City Council of the City of Darien hereby authorizes the Mayor and City Clerk to accept a proposal from Vermeer Midwest for the purchase of one (1) new Vermeer BC1800XL Brush Chipper in an amount not to exceed \$70,965.00, a copy of which is attached hereto as "**Exhibit A**".

SECTION 2: This Resolution shall be in full force and effect from and after its passage and approval as provided by law.

PASSED BY THE CITY COUNCIL OF THE CITY OF DARIEN, DU PAGE COUNTY, ILLINOIS, this 2nd day of May, 2016.

AYES: _____

NAYS: _____

ABSENT: _____

APPROVED BY THE MAYOR OF THE CITY OF DARIEN, DU PAGE COUNTY, ILLINOIS, this 2nd day of May, 2016.

KATHLEEN MOESLE WEAVER, MAYOR

ATTEST:

JOANNE E. RAGONA, CITY CLERK

APPROVED AS TO FORM

CITY ATTORNEY

2016 Vermeer Corporation
 NJPA Landscape Equipment Contract # 070313-VRM

QUOTE
 ORDER



BC1800XL - 19" Brush Chipper with Tier 4F Engine

Basic Unit - 130 HP Cummins (Use this pricing if specifications beyond those shown below are desired)

BC1800XL Brush Chipper (19" capacity drum style) w/ 130 hp Cummins 3.8L Tier 4 Final turbocharged diesel engine, high coolant temperature and low oil pressure automatic shutdown, precleaner, DEF tank, springloaded clutch, live hydraulics, variable speed dual vertical feed rollers, selectable SmartFeed, pintle hitch, lockable battery box, lockable control panel, lockable engine doors, lockable toolbox, infeed curtain, dual-edged knives, selected ECOIdle, Tree Commander remote control system (115); non winch option (131); heavy duty manual jack (139); 10,000 lb. axle w/ torsion suspension and electric brakes, telescoping tongue, 235/75R 17.5 radial tires w/o winch (135); LED lights (155); 6-way round trailer plug (040); right side controls (includes clutch handle and deluxe instrument panel located on right side of machine - deluxe instrument panel includes multifunction display (MFD), fuel gauge and DEF gauge (151); manually operated discharge/chip chute rotation and deflector (015)

For additional options, see "Optional Features" section below.

Basic Unit Price:

Value Package (15M) (Receive additional savings by ordering your unit with the most commonly requested specifications)

To receive add savings, order unit as specified above, "As Is" with NO change to options shown above.

Value Package Price:

Basic Unit - 173 HP John Deere (Use this pricing if specifications beyond those shown below are desired)

BC1800XL Brush Chipper (19" capacity drum style) w/ 173 hp John Deere 4045 Tier 4 Final turbocharged diesel engine, high coolant temperature and low oil pressure automatic shutdown, precleaner, DEF tank, springloaded clutch, live hydraulics, variable speed dual vertical feed rollers, selectable SmartFeed, pintle hitch, lockable battery box, lockable control panel, lockable engine doors, lockable toolbox, infeed curtain, dual-edged knives, selected ECOIdle, Tree Commander remote control system (115); non winch option (131); heavy duty manual jack (139); 10,000 lb. axle w/ torsion suspension and electric brakes, telescoping tongue, 235/75R 17.5 radial tires w/o winch (135); LED lights (155); 6-way round trailer plug (040); right side controls (includes clutch handle and deluxe instrument panel located on right side of machine - deluxe instrument panel includes tachometer w/ LCD screen that can display hours, oil pressure, water temperature and engine error codes) (153); manually operated discharge/chip chute rotation and deflector (015)

For additional options, see "Optional Features" section below.

Basic Unit Price:

Value Package (15VP) (Receive additional savings by ordering your unit with the most commonly requested specifications)

To receive add savings, order unit as specified above, "As Is" with NO change to options shown above.

Value Package Price: **\$70,155.00**

To receive "Optional Features" below, add to "Basic Unit" price above to arrive at final pricing. **DO NOT** add to "Value Package" pricing:

Optional Features:

- Winch w/ manual right side hydraulic directional controls (093); in lieu of no winch (131) (Must include sales code -133 or -141 below when choosing this option)
- Heavy duty hydraulic jack (140); in lieu of heavy duty manual jack (139)
- Hydraulic Brakes w/ fixed tongue (133); in lieu of electric brakes (135)
- Electric Brakes w/ Winch Option (141); in lieu of non winch option (135)
- Right side manual tall discharge/chip chute (016)
- Manual height adjustable discharge chip chute (012)
- Hydraulic discharge/chip chute (rotate & deflect) (078)
- Hydraulic tall discharge/chip chute (rotate & deflect) (079)
- Hyd rotation & manual height adjustable chute (080)
- Biodegradable Hydraulic Oil (098)
- Miscellaneous Features: sales code _____

Add to Basic Unit Price:

	\$ _____
Subtotal:	\$70,155.00
Dealer Freight & Prep:	\$810.00
Quantity:	1
Total:	\$70,965.00
Enter Sales Tax %:	Sales Tax: TBD
Grand Total	\$70,965.00

Pricing effective 04/01/16
 NOTE: All pricing in USD \$
 NOTE: Include applicable sales tax
 Quotes valid for 30 days

ACCEPTED:

Vermeer
 BY: _____
 DATE: _____

Customer
 BY: _____
 DATE: _____

Any applicable sales tax is not included. Prices subject to change without notice. These prices are exclusive of any and all duties, import fees, taxes, or other similar charges. These prices may not be available in any transaction involving a trade or rental transaction. This sheet may not include all possible specifications available for this model. For complete product specifications, please contact your local authorized Vermeer dealer. Unless otherwise noted, dealer freight & prep to be determined.



FORM D

Formal Offering of Proposal
(To be completed Only by Proposer)



GROUNDS MAINTENANCE WITH RELATED EQUIPMENT, ACCESSORIES AND SUPPLIES.

In compliance with the Request for proposal (RFP) for "GROUNDS MAINTENANCE WITH RELATED EQUIPMENT, ACCESSORIES AND SUPPLIES", the undersigned warrants that I/we have examined this RFP and, being familiar with all of the instructions, terms and conditions, general specifications, expectations, technical specifications, service expectations and any special terms, do hereby propose, fully commit and agree to furnish the defined equipment/products and related services in full compliance with all terms, conditions of this RFP, any applicable amendments of this RFP, and all Proposer's Response documentation. Proposer further understands they accept the full responsibility as the sole source of responsibility of the proposed response herein and that the performance of any sub-contractors employed by the Proposer in fulfillment of this proposal is the sole responsibility of the Proposer.

Company Name: Vermeer Corporation Date: 06/24/2013

Company Address: 1210 Vermeer Road East

City: Pella State: IA Zip: 50219

Contact Person: Jerry Beyer Title: Sr. Global Accounts Manager

Authorized Signature (ink only): *Jerry Beyer* Jerry Beyer
(Name printed or typed)



Contract Acceptance and Award

(To be completed only by NJPA)

NJPA 070313 GROUNDS MAINTENANCE WITH RELATED EQUIPMENT, ACCESSORIES AND SUPPLIES

Vermeer Corporation

Proposer's full legal name

Your proposal is hereby accepted and awarded. As an awarded Proposer, you are now bound to provide the defined product/equipment and services contained in your proposal offering according to all terms, conditions, and pricing set forth in this RFP, any amendments to this RFP, your Response, and any exceptions accepted or rejected by NJPA on Form C.

The effective date of the Contract will be September 11, 2013 and continue for four years thereafter AND which is subject to annual renewal at the option of both parties. This contract has the consideration of an optional fifth year renewal option at the discretion NJPA.

National Joint Powers Alliance® (NJPA)

NJPA Authorized signature:

[Signature]
NJPA Executive Director

Cheryl Cocumelle
(Name printed or typed)

Awarded this

20th

day of August

20 13

NJPA Contract Number # 070313 - VPM

NJPA Authorized signature:

[Signature]
NJPA Board Member

Scott Veroneri
(Name printed or typed)

Executed this

20th

day of August

20 13

NJPA Contract Number # 070313 - VPM

Proposer hereby accepts contract award including all accepted exceptions and NJPA clarifications identified on FORM C.

Vendor Name Vermeer Corporation

Vendor Authorized signature:

[Signature]

Jerry Beyer

(Name printed or typed)

Title: Sr. Global Accounts Manager

Executed this

20th

day of August

20 13

NJPA Contract Number # 070313 - VPM

ANNUAL RENEWAL OF AGREEMENT

Made by and Between

Vermeer Corporation (Vendor)
1210 Vermeer Road East
Pella, IA 50219

and

National Joint Powers Alliance® (NJPA)
202 12th Street NE
Staples, MN 56479
Phone: (218) 894-1930

Whereas:

"Vendor" and "NJPA" have entered into an "Acceptance and Award #070313-VRM" for the procurement of Grounds Maintenance with Related Equipment, Accessories and Supplies, and having a maturity date of August 20, 2017, and which are subject to annual renewals at the option of both parties.

Now therefore:

"Vendor" and "NJPA" hereby desire and agree to extend and renew the above defined contract for the period of August 20, 2015 to August 20, 2016.

National Joint Powers Alliance® (NJPA)

By: [Signature], Its: Executive Director/CEO

Name printed or typed: Chad Coquette

Date: 8/5/15

Vermeer Corporation

By: [Signature], Its: Sr. Corporate Accounts Manager

Name printed or typed: Jerry Beyer

Date: 08/05/2015

If you do not desire to extend contract, please sign below and return this agreement.
Discontinue: We desire to discontinue the contract.

Signature: _____ Date: _____

AGENDA MEMO
Municipal Services Committee
April 25, 2016

ISSUE STATEMENT

A resolution authorizing the purchase of one new 2016 Caterpillar Loader Model No 926M Small Wheel Loader from Patten Cat in an amount not to exceed \$147,500.

BACKGROUND/HISTORY

The proposed backhoe and loader is utilized daily for various loading and unloading activities within the Streets Division. The proposed equipment would be replacing Unit 203, 2002 IT28G Front-End loader. It received a rating of 77.54 during this year's mechanic evaluation. The Front-End loader is experiencing severe rusting of the body. The machine is experiencing various hydraulic oil leaks and the lifting mechanisms are in need of replacement. Attached and labeled as **Attachment A** is the vehicle rating and repairs to date. The existing machine will be declared as surplus and a separate agenda memo will be presented at a later date for City Council approval.

Staff has selected Patten Cat to supply the machine and is the awarded vendor for the National Intergovernmental Purchasing Alliance-National IPA City of Darien Participation Agency Member No. 228633, for equipment sales to municipalities nationally. Attached and labeled as **Attachment B** pages 1-8 is information regarding National IPA. Attached and labeled as **Attachment C**, is the cost breakdown and specifications for the 2016 Caterpillar Loader.

The proposed expenditure would be expended from the following line account:

ACCOUNT NUMBER	ACCOUNT DESCRIPTION	FY16-17 BUDGET	PROPOSED EXPENDITURE	PROPOSED BALANCE
01-30-4815	CAPITAL PURCHASES END LOADER	\$163,500	\$ 147,500	\$ 16,000

STAFF RECOMMENDATION

Staff recommends approval of the resolution authorizing the purchase of one new 2016 Caterpillar Loader Model No 926M Small Wheel Loader from Patten Cat in an amount not to exceed \$147,500.

ALTERNATE DECISION

As recommended by the Committee.

DECISION MODE

This item will be on the May 2, 2016 City Council agenda for formal consideration.

CRITERIA FOR REPLACING CITY VEHICLES AND EQUIPMENT				
UNIT NO	203	DEPARTMENT	Street	DATE
MODEL YEAR	2001	MODEL	ET 28G	10-25-15
CURRENT MILEAGE		CURRENT HOURS	10576	
			MAXIMUM POINTS	VEHICLE SCORE
AGE				
	Department	Street		
	Life Expectancy	12		
	Age as of Report Date	14		
	AGE: Meets Requirements	Yes	20	20
USAGE				
	MILES			
	HOURS	10576		
	ATTACHMENT C OF THE VEHICLE REPLACEMENT POLICY			
	USAGE: Meets Requirements		20	17.54
TYPE OF SERVICE				
	I-LIGHT DUTY			
	I5-CRITICAL DUTY			
	SERVICE: Meets Requirements		15	11
RELIABILITY				
	RELIABILITY: Frequency or Visits for Service			
	RELIABILITY: Meets Requirements		15	7
MAINTENANCE AND REPAIR COSTS				
	REPAIRS: Cost per Mile/Hours Exceeds Vehicle in Class			
	ORIGINAL PURCHASE PRICE	95,000.00		
	LIFE TO DATE REPAIR COST	12,436.60		
	PERCENTAGE OF REPAIRS TO PURCHASE PRICE	13.09%		

UNIT NO	203	DEPARTMENT	Street	DATE
MODEL YEAR	2001	MODEL	IT 28 G	10-25-15
CURRENT MILEAGE		CURRENT HOURS	6576	
			MAXIMUM POINTS	VEHICLE SCORE
PERCENTAGES OF REPAIR POINTS	POINTS			
1 THROUGH 20	2			
21 THROUGH 40	4			
41 THROUGH 60	6			
61 THROUGH 80	8			
81 THROUGH 100	10			
	REPAIRS: Meets Requirements		10	3
CONDITION				
	CONDITION OF ENGINE COMPONENTS (MAJOR REPAIRS NEEDED OR ANTICIPATED). BODY (BODY SHEET METAL, RUSTED, STRUCTURAL COMPONENTS)			
	CONDITION: Meets Requirements		15	15
TECHNOLOGICAL ADVANCEMENTS	FUEL EMISSIONS, SAFETY FEATURES, ERGONOMICS		5	5
TOTAL POINTS			100	77.54

CITY OF DARIEN
 Repair Transaction Cost Detail

Equipment#	Repair Order#	Date	Motor(1)	Shop Loc/ Rep Class	Rep Reason/ Rep Site			
203	0000024665	08/12/02	101	/01	08/01			
	<u>Group-System</u>			<u>Mech/Vendor</u>	<u>Work Acc</u>	<u>Part(\$)</u>	<u>Labor(\$)</u>	<u>Hours</u>
	01-PMA - PREV. MAINT.			001		23.10	42.00	1.50
203	0000024674	07/08/02	101	/01	08/01			
	01-PMC - PREV. MAINT.			001		0.00	14.00	0.50
203	0000024965	02/28/03	335	/01	08/01			
	01-PMA - PREV. MAINT.			001		240.83	56.00	2.00
	01-PMC - PREV. MAINT.			001		0.00	14.00	0.50
203	0000024966	03/03/03	335	/01	08/01			
	01-PMB - PREV. MAINT.			001		0.00	14.00	0.50
203	0000025291	11/12/03	477	/01	08/01			
	01-PMC - PREV. MAINT.			001		0.00	28.00	1.00
203	0000025485	05/12/04	690	/01	08/01			
	01-PMA - PREV. MAINT.			001		27.10	56.00	2.00
	01-PMC - PREV. MAINT.			001		0.00	14.00	0.50
203	0000025541	06/21/04	695	/01	08/01			
	01-PMB - PREV. MAINT.			001		305.36	56.00	2.00
203	0000025753	12/07/04	801	01/01	08/01			
	01-PMC - PREV. MAINT.			001		0.00	84.00	3.00
203	0000025842	02/22/05	943	01/01	08/01			
	07-44 - FUEL SYS			001		202.27	56.00	2.00
203	0000025851	03/04/05	950	/01	08/01			
	01-PMA - PREV. MAINT.			001		43.96	56.00	2.00
	01-PMB - PREV. MAINT.			001		173.03	56.00	2.00
203	0000025964	06/13/05	999	/01	08/01			
	01-PMC - PREV. MAINT.			002		0.00	15.00	1.00
203	0000026010	07/25/05	1015	/02	04/01			
	02-19 - WHEELS/RIMS			001		109.79	28.00	1.00
203	0000026023	08/03/05	1920	/02	01/01			
	09-63 - HOSES & FITTING			001		75.97	28.00	1.00
203	0000026243	01/05/06	1191	/01	08/01			
	01-PMA - PREV. MAINT.			001		43.98	14.00	0.50
203	0000026302	02/15/06	1235	/01	08/01			
	01-PMB - PREV. MAINT.			001		262.60	56.00	2.00
203	0000026469	05/15/06	1245	/01	08/01			
	01-PMC - PREV. MAINT.			001		0.00	14.00	0.50
203	0000027102	12/13/06	1518	/01	08/01			
	01-PMA - PREV. MAINT.			001		45.18	56.00	2.00
	01-PMB - PREV. MAINT.			001		114.50	28.00	1.00
	01-PMC - PREV. MAINT.			001		0.00	14.00	0.50
	03-07 - INTERIOR			001		59.03	14.00	0.50
203	0000027353	07/11/07	1880	/01	08/01			
	01-PMA - PREV. MAINT.			001		44.43	28.00	1.00
	01-PMB - PREV. MAINT.			001		160.66	42.00	1.50
203	0000027405	08/23/07	1990	/01	08/01			
	01-PMC - PREV. MAINT.			001		0.00	14.00	0.50

CITY OF DARIEN
 Repair Transaction Cost Detail

Equipment#	Repair Order#	Date	Matnr(i)	Shop Loc/ Rep Class	Rep Reason/ Rep Site			
203	0000027444	09/20/07	1990	/01	08/01			
	<u>Group-System</u>			<u>Mech/Vendor</u>	<u>Work Acc</u>	<u>Part(\$)</u>	<u>Labor(\$)</u>	<u>Hours</u>
	03-10 - WIPERS/WASHERS			002		198.62	45.00	3.00
	09-57 - HYDRAULIC SYS			002		698.52	75.00	5.00
203	0000027760	03/12/08	2312	/01	08/01			
	01-PMA - PREV. MAINT.			001		57.84	28.00	1.00
	01-PMB - PREV. MAINT.			001		210.35	56.00	2.00
	01-PMC - PREV. MAINT.			001		0.00	28.00	1.00
203	0000028023	08/25/08	2359	/01	08/01			
	09-57 - HYDRAULIC SYS			001		438.79	56.00	2.00
203	0000028089	10/16/08	2500	/01	08/01			
	01-PMC - PREV. MAINT.			001		0.00	28.00	1.00
203	0000028143	11/21/08	2524	/01	08/01			
	01-PMA - PREV. MAINT.			001		41.46	56.00	2.00
203	0000028248	02/06/09	2865	/01	08/01			
	01-PMA - PREV. MAINT.			001		122.22	56.00	2.00
	01-PMB - PREV. MAINT.			001		193.63	56.00	2.00
	06-30 - SAFETY EQUIP			001		82.60	0.00	0.00
203	0000028367	05/20/09	2961	/01	08/01			
	01-PMA - PREV. MAINT.			002		47.49	22.50	1.50
	07-41 - AIR INTAKE SYS			002		98.91	7.50	0.50
203	0000028427	07/02/09	3029	/01	08/01			
	01-PMC - PREV. MAINT.			002		0.00	7.50	0.50
203	0000028506	09/01/09	3090	/01	08/01			
	12-94 - CUTTING EDGES			001		58.50	28.00	1.00
203	0000028523	09/17/09	3098	/01	08/01			
	03-07 - INTERIOR			002		266.68	15.00	1.00
203	0000028612	11/25/09	3146	01/02	01/01			
	03-02 - HEATER-VENT			001		66.66	84.00	3.00
203	0000028656	12/16/09	3200	01/01	08/01			
	01-PMA - PREV. MAINT.			001		50.42	112.00	4.00
	01-PMB - PREV. MAINT.			001		213.21	0.00	0.00
	01-PMC - PREV. MAINT.			001		0.00	0.00	0.00
203	0000028780	04/22/10	3450	01/01	08/01			
	01-PMA - PREV. MAINT.			001		47.49	70.00	2.50
	01-PMB - PREV. MAINT.			001		0.00	14.00	0.50
203	0000028788	04/13/10	3447	01/02	01/01			
	06-35 - BATTERY			002		215.98	30.00	2.00
203	0000028917	07/30/10	3560	01/01	08/01			
	01-PMC - PREV. MAINT.			001		0.00	56.00	2.00
203	0000029055	11/12/10	3658	01/02	01/01			
	04-15 - STEERING			001		74.95	42.00	1.50
203	0000029075	12/03/10	3697	01/01	08/01			
	01-PMA - PREV. MAINT.			002		45.87	33.75	2.25
203	0000029157	02/23/11	4028	01/01	08/01			
	01-PMA - PREV. MAINT.			002		45.62	30.00	2.00
	01-PMB - PREV. MAINT.			002		140.41	11.25	0.75

CITY OF DARIEN
 Repair Transaction Cost Detail

Equipment#	Repair Order#	Date	Meter(1)	Shop Loc/ Rep Class	Rep Reason/ Rep Site			
	01-PMC - PREV. MAINT.			002		0.00	0.00	0.00
203	0000029354	08/02/11	4152	01/02	01/01			
	<u>Group-System</u>			<u>Mech/Vendor</u>	<u>Work Acc</u>	<u>Part(\$)</u>	<u>Labor(\$)</u>	<u>Hours</u>
	05-23 - CLUTCH			002		285.97	22.50	1.50
203	0000029429	10/01/11	4295	01/03	01/01			
	09-83 - HOSES & FITTING			002		86.88	45.00	3.00
203	0000029461	10/26/11	4422	01/01	08/01			
	01-PMC - PREV. MAINT.			002		0.00	0.00	0.00
	01-PMB - PREV. MAINT.			002		128.71	15.00	1.00
	01-PMA - PREV. MAINT.			002		13.66	7.50	0.50
	07-41 - AIR INTAKE SYS			002		102.09	7.50	0.50
203	0000029542	01/04/12	4430	01/02	01/01			
	09-57 - HYDRAULIC SYS			002		936.55	60.00	4.00
203	0000029594	01/30/12	4381	01/02	01/01			
	02-17 - TIRES,TUBES,ETC			002		2,374.00	90.00	6.00
203	0000029595	01/30/12	4381	01/02	01/01			
	02-17 - TIRES,TUBES,ETC			002		2,374.00	90.00	6.00
203	0000029726	05/02/12	4541	01/01	08/01			
	01-PMC - PREV. MAINT.			002		0.00	15.00	1.00
203	0000029805	07/10/12	4625	01/03	01/01			
	08-34 - LIGHTING SYS			002		128.24	15.00	1.00
203	0000029816	07/16/12	4627	01/02	08/01			
	01-PMA - PREV. MAINT.			002		70.41	18.75	1.25
	01-PMC - PREV. MAINT.			002		0.00	3.75	0.25
	07-41 - AIR INTAKE SYS			002		53.78	3.75	0.25
203	0000029996	12/10/12	4802	01/01	08/01			
	01-PMA - PREV. MAINT.			002		79.99	33.75	2.25
	07-41 - AIR INTAKE SYS			002		52.90	3.75	0.25
	09-57 - HYDRAULIC SYS			002		27.59	22.50	1.50
203	0000030103	04/02/13	5018	01/01	08/01			
	03-07 - INTERIOR			002		274.21	15.00	1.00
	01-PMA - PREV. MAINT.			002		68.82	11.25	0.75
	01-PMB - PREV. MAINT.			002		128.71	11.25	0.75
	01-PMC - PREV. MAINT.			002		0.00	7.50	0.50
203	0000030319	10/17/13	5147	01/03	01/01			
	06-36 - MARS & STROBE			002		151.88	3.75	0.25
203	0000030373	12/31/13	5313	01/01	08/01			
	01-PMB - PREV. MAINT.			002		190.84	30.00	2.00
	01-PMA - PREV. MAINT.			002		71.14	30.00	2.00
	07-41 - AIR INTAKE SYS			002		52.90	3.75	0.25
203	0000030561	06/24/14	5878	01/03	01/01			
	10-76 - LOADER			002		279.97	7.50	0.50
203	0000030566	06/25/14	5879	01/03	01/01			
	01-PMA - PREV. MAINT.			002		82.34	30.00	2.00
	01-PMB - PREV. MAINT.			002		177.67	0.00	0.00
203	0000030601	08/08/14	5952	01/03	01/01			
	02-17 - TIRES,TUBES,ETC			002		1,186.50	45.00	3.00

CITY OF DARIEN
 Repair Transaction Cost Detail

Equipment#	Repair Order#	Date	Meter(1)	Shop Loc/ Rep Class	Rep Reason/ Rep Site			
203	0000030732	11/24/14	6137	01/03	01/01			
	<u>Group-System</u>			<u>Mech/Vendor</u>	<u>Work Acc</u>	<u>Part(\$)</u>	<u>Labor(\$)</u>	<u>Hours</u>
	12-94 - CUTTING EDGES			002		758.52	22.50	1.50
	10-78 - LOADER			002		428.18	15.00	1.00
	07-41 - AIR INTAKE SYS			002		57.44	3.75	0.25
203	0000030734	11/25/14	6137	01/01	08/01			
	01-PMA - PREV. MAINT.			002		71.14	30.00	2.00
	01-PMB - PREV. MAINT.			002		70.27	7.50	0.50
	01-PMC - PREV. MAINT.			002		0.00	3.75	0.25
203	0000030762	12/23/14	6162	01/02	04/01			
	03-07 - INTERIOR			002		42.16	15.00	1.00
203	0000030768	01/14/15	6162	01/03	01/01			
	07-41 - AIR INTAKE SYS			002		107.31	3.75	0.25
203	0000030845	04/17/15	6489	01/03	01/01			
	09-63 - HOSES & FITTING			002		52.28	60.00	4.00
203	0000030934	06/26/15	6576	01/01	08/01			
	01-PMA - PREV. MAINT.			002		73.12	22.50	1.50
	01-PMB - PREV. MAINT.			002		132.89	7.50	0.50
203	0000031038	01/04/16	6819	01/03	01/01			
	09-63 - HOSES & FITTING			002		91.49	45.00	3.00
				Grand Total		<u>16,588.54</u>	<u>2,829.50</u>	<u>137.50</u>



**Heavy Equipment, Parts, Accessories, Supplies & Related Services
Executive Summary**

Lead Agency: City of Tucson, AZ
RFP issued: October 18, 2011
Date Open: November 14, 2011

Solicitation: RFP #120377
Pre-Proposal Date: October 27, 2011
Proposals Received: 4

Awarded to: Caterpillar

The City of Tucson, AZ Department of Procurement issued RFP #120377 on October 18, 2011 to establish a national cooperative contract for heavy equipment, parts, accessories, supplies and related services.

Notice of the solicitation was sent to potential offerors, as well as advertised in the following:

- City of Tucson, AZ website
- Hawaii Tribune-Herald, HI
- Daily Journal of Commerce, OR
- The State, SC
- The Olympian, WA
- National IPA website

On November 14, 2011 proposals were received from the following offerors:

- Badger Equipment Company
- Caterpillar
- Federal Contracts Corporation
- PB Loader Corporation

The proposals were evaluated by an evaluation committee. Using the evaluation criteria established in the RFP, the committee elected to enter into interview and negotiations with the top ranked firm, Caterpillar.

The City of Tucson, AZ, National IPA and Caterpillar successfully negotiated a contract and the City of Tucson executed the agreement with a contract effective date of May 2, 2012.

Caterpillar

Contract includes: Heavy equipment, parts, accessories, supplies and related services

Term:

Initial one year agreement from May 2, 2012 through May 1, 2013, with option to renew for four (4) additional one-year periods through May 1, 2017.

Pricing/Discount:

Minimum discount off list price.

Serviced and supported by local Cat dealers.

Value Added Services:

- Financing options
- Used equipment
- Rentals
- Extended warranties
- Maintenance agreements
- Trade-in or Buyback options

Caterpillar Product and Service Pricing

<u>Model</u>	<u>Minimum Member Discount</u>
Articulated Trucks	14%
Backhoe Loaders	21%
Generators	17% - 50%
Integrated Tool Carriers	21% - 26%
Landfill Compactors	14%
Motor Graders	23% - 37%
Paving Products	14% - 18%
Skid Steer Loaders	16%
Towed Scrapers	15%
Track Excavators	12% - 25%
Track Loaders	20% - 23%
Track Type Tractors	10% - 25%
Tractor Scrapers	15% - 17%
Vocational Trucks	23%
Wheel Dozers	15%
Wheel Loaders	12% - 26%
Wheeled Excavators	32% - 35%
Work tools	15%

The following items are also available under the contract:

- Financing Options
- Used Equipment - subject to availability, 20% discount off the original list price of used Caterpillar equipment that is currently in the Cat Dealers rental fleet, excluding vocational trucks and work tools
- Used Vocational Trucks & Work Tools - pricing to be negotiated with local participating dealer
- Rentals - product and service pricing to be negotiated with local participating dealer
- Accessories/Allied Products (trailers, etc.) - product pricing to be negotiated with local participating dealer
- Parts - product pricing to be negotiated with local participating dealer
- Service/Repair - product pricing to be negotiated with local participating dealer
- Extended Warranties - product pricing to be negotiated with local participating dealer
- Maintenance Agreements - product pricing to be negotiated with local participating dealer
- Trade-in or Buyback Options - to be negotiated with local participating dealer

2015 Caterpillar Coop Contract Discounts V6

Machines	New Equipment	Used Equipment
2015	Discount off List	Discount from original List
Pavers		
AP255	16.00%	20.0%
AP500	16.00%	20.0%
AP555	16.00%	20.0%
AP600	16.00%	20.0%
AP655	16.00%	20.0%
AP1000	16.00%	20.0%
AP1055	16.00%	20.0%
Rollers		
CB14	16.00%	20.0%
CB22	16.00%	20.0%
CB24	16.00%	20.0%
CB32	16.00%	20.0%
CB34/CB34XW	16.00%	20.0%
CB44	16.00%	20.0%
CB54	16.00%	20.0%
CB64	16.00%	20.0%
CC24	16.00%	20.0%
CC34	16.00%	20.0%
CD44	16.00%	20.0%
CD54	16.00%	20.0%
CP34	14.00%	20.0%
CP44	14.00%	20.0%
CP54	14.00%	20.0%
CP56	14.00%	20.0%
CP68	14.00%	20.0%
CP74	14.00%	20.0%
CS34	14.00%	20.0%
CS44	14.00%	20.0%
CS54	14.00%	20.0%
CS64	14.00%	20.0%
CS68	14.00%	20.0%
CS78	14.00%	20.0%
CW14	16.00%	20.0%
CW34	16.00%	20.0%
Vocational Trucks		
CT680	23.00%	20.0%
CT680	23.00%	20.0%
CT681	23.00%	20.0%

2015 Caterpillar Coop Contract Discounts V6

Track Type Tractors		
D3	25.00%	20.0%
D4	24.00%	20.0%
D5	25.00%	20.0%
D6	24.00%	20.0%
D7	22.00%	20.0%
D8	22.00%	20.0%
D9	10.00%	20.0%
Integrated Tool Carriers		
IT62	21.00%	20.0%
Cold Planners		
PM102	14.00%	20.0%
PM200	14.00%	20.0%
PM201	18.00%	20.0%
Reclaimers		
RM300	14.00%	20.0%
RM500	14.00%	20.0%
Wheeled Excavators		
M313	35.00%	20.0%
M314	18.00%	20.0%
M315	32.00%	20.0%
M316	35.00%	20.0%
M318	32.00%	20.0%
M320	21.00%	20.0%
M322	35.00%	20.0%
Motor Graders		
12	33.00%	20.0%
120	37.00%	20.0%
140	33.00%	20.0%
160	33.00%	20.0%
14	23.00%	20.0%

2015 Caterpillar Coop Contract Discounts V6

Skid Steer Loaders		
226	16.00%	20.0%
232	16.00%	20.0%
236	16.00%	20.0%
242	16.00%	20.0%
246	16.00%	20.0%
262	16.00%	20.0%
272	16.00%	20.0%
Multi-Terrain Loaders		
247	16.00%	20.0%
257	16.00%	20.0%
277	16.00%	20.0%
287	16.00%	20.0%
297	16.00%	20.0%
Compact Track Loaders		
239	16.00%	20.0%
249	16.00%	20.0%
259	16.00%	20.0%
279	16.00%	20.0%
289	16.00%	20.0%
299	16.00%	20.0%
Excavators		
300.9	17.50%	20.0%
301.4	17.50%	20.0%
301.7	17.50%	20.0%
302.4	17.50%	20.0%
302.7	17.50%	20.0%
303	17.50%	20.0%
303.5	17.50%	20.0%
304	17.50%	20.0%
305	17.50%	20.0%
305.5	17.50%	20.0%
308	17.50%	20.0%
311	24.00%	20.0%
312	21.00%	20.0%
313	21.00%	20.0%
314	25.00%	20.0%
316	25.00%	20.0%
318	22.00%	20.0%
319	22.00%	20.0%
320	18.00%	20.0%
321	18.00%	20.0%
323	18.00%	20.0%

2015 Caterpillar Coop Contract Discounts V6

324	18.00%	20.0%
325	18.00%	20.0%
328	18.00%	20.0%
329	18.00%	20.0%
335	18.00%	20.0%
336	18.00%	20.0%
345	12.00%	20.0%
349	12.00%	20.0%
352	12.00%	20.0%
374	10.00%	20.0%
Backhoe Loaders		
416	21.00%	20.0%
420	21.00%	20.0%
430	21.00%	20.0%
450	21.00%	20.0%
Wheel Tractor Scrapers		
621	16.00%	20.0%
623	17.00%	20.0%
627	16.00%	20.0%
Articulated Trucks		
725	14.00%	20.0%
730	14.00%	20.0%
735	14.00%	20.0%
740	14.00%	20.0%
745	14.00%	20.0%
Rigid Frame Trucks		
770	10.00%	20.0%
773	10.00%	20.0%
Landfill Compactors		
815	14.00%	20.0%
816	14.00%	20.0%
825	14.00%	20.0%
826	14.00%	20.0%
836	14.00%	20.0%
Wheel Dozers		
814	15.00%	20.0%
824	15.00%	20.0%

2015 Caterpillar Coop Contract Discounts V6

Wheel Loaders		
903	25.00%	20.0%
906	25.00%	20.0%
907	25.00%	20.0%
908	25.00%	20.0%
910	25.00%	20.0%
914	25.00%	20.0%
924	26.00%	20.0%
930	26.00%	20.0%
938	26.00%	20.0%
950	24.00%	20.0%
962	24.00%	20.0%
966	21.00%	20.0%
972	16.00%	20.0%
980	12.00%	20.0%
982	12.00%	20.0%
Track Loaders		
953	20.00%	20.0%
963	23.00%	20.0%
973	23.00%	20.0%
Telehandlers		
TH255	12.00%	20.0%
TH406	12.00%	20.0%
TH407	12.00%	20.0%
TH514	12.00%	20.0%
TL642	12.00%	20.0%
TL943	12.00%	20.0%
TL1055	12.00%	20.0%
TL1255	12.00%	20.0%
Worktools		
	15.00%	
Caterpillar Safety Services		
	15.00%	N/A



Quote 112404-01

March 25, 2016

CITY OF DARIEN/PUBLIC WORKS
1702 PLAINFIELD ROAD
DARIEN
Illinois
60561

Attention: KRIS THROM

Dear Kris,

We would like to thank you for your interest in our company and our products, and are pleased to quote the following for your consideration.

CATERPILLAR Model: 926M SMALL WHEEL LOADER

**ASK ABOUT THE "CAT PAYS YOU BACK" FUEL CONSUMPTION REBATE PROGRAM FOR THIS MACHINE
(PLEASE SEE ATTACHED BROCHURE)**

STOCK NUMBER: X5057 SERIAL NUMBER: OLTE01912 YEAR: 2016

We wish to thank you for the opportunity of quoting on your equipment needs. This quotation is valid for 30 days, after which time we reserve the right to re-quote. If there are any questions, please do not hesitate to contact me. In closing, we do greatly appreciate this opportunity to earn your business. We are confident that our products, backed by our unparalleled product support after the sale, will exceed your expectations.

Sincerely,

Pete Swanson

Pete Swanson
Machine Sales Representative

CATERPILLAR Model: 926M SMALL WHEEL LOADER

STANDARD EQUIPMENT

POWERTRAIN -Axle seal guards -Auto Idle shut down feature -Cat C7.1ACERT engine -Power Modes (Standard and Performance) -Power by Range (High Power in Range 4) -Tier 4 Final/Stage IV compliant -Turbocharged and after cooled -Filtered crankcase breather -Diesel particulate filter -Selective Catalyst Reduction -Coolant protection to -34C (-29F) -Differential lock in front axle -Dry type air cleaner -Enclosed wet disc full hydraulic brakes -Fuel priming pump, automatic -Fuel water separator -Hydraulically driven demand cooling fan -Hydrostatic transmission with electronic -controls -Operator Modes (Default, TC, Hydrostat and -Ice) -Directional Shift Aggressiveness (Fast, -Medium, Slow) -Rim pull control, adjust wheel torque -Creaper control, adjust ground speed -Lubed for life drivshafts -Parking brake, electric -ingle plane cooling package wide 8 fins -per inch density -S-O-S port, engine, coolant, transmission oil

HYDRAULICS -Automatic lift and bucket kick outs, -adjustable in-cab -Bucket and Fork Modes, adjustable in-cab -Cylinder damping at Kickout and -mechanical end stops -Fine Mode control (Fast, Medium, Slow) -in Fork Mode -Hydraulic Response setting (Fast, -Medium, Slow) -Hydraulic diagnostic connectors and -S-O-S ports -Hydraulic sight gauge, visible -Load sensing hydraulics and steering -Seat mounted hydraulic joystick controls

ELECTRICAL -Alternator, 115-amp, heavy duty -12V power supply in cab (2) -Batteries, 1,000 CCA (2) 24 volt system, -disconnect switch -Back up alarm -Emergency shutdown switch -Halogen work lights front and rear, LED -rear stop and turn lights -Heavy duty gear reduction starter -Product Link PRO w/3 year subscription -Remote jump start post -Resettable main and critical function -breakers -Roading lights front and rear

OPERATOR ENVIRONMENT -75 mm (3 in) retractable seatbelt -Automatic temperature control -Cab, enclosed ROPS/FOPS pressurized -and sound suppressed -Cup holders -External heated mirrors with lower -parabolic -Ground level cab door release -Gauges; - Digital hour meter, odometer and -tachometer - Digital ground speedometer and -direction indicator - Engine coolant temperature gauge - Fuel and Diesel Exhaust Fluid level - Indicator - Hydraulic oil temperature gauge -Hydraulic control lockout -Interior cab lighting, door and dome -Interior rearview mirrors (2) -Lunch box storage -Operator warning system indicators -Radio ready speakers -Rear window defrost, electric -Seat mounted electronic implement -controls, adjustable -Sliding glass on the side windows -Column mounted multi function control -lights, wipers, turn signal -Suspension seat, fabric -Tilt and telescope steering wheel -Tinted front glass -Wet arm wiper/washer, 2-speed and -intermittent, front -Wet arm wiper washer, rear -Large-access enclosure doors with

OTHER STANDARD EQUIPMENT -Large-access enclosure doors with -adjustable close/open force -Parallel lift loader linkage -Recovery hitch with pin -Remote mounted lubrication points -Vandalism protection- -lockable compartments



MACHINE SPECIFICATIONS

Description	Reference No
920M WHEEL LOADER	430-2805
FENDERS, STANDARD	366-8148
CAB, DELUXE	423-7162
SEAT, DELUXE	423-7201
STEERING, STANDARD	430-2996
DIFFERENTIAL, OPEN REAR	333-6528
HYD,3V,COUPLER READY,STD LIFT	430-2823
COUNTERWEIGHT, HEAVY	348-2579
RIDE CONTROL	430-2859
RADIO, BLUETOOTH, AUX, MIC	372-1868
TIRES,20.5/25 FS SGGLD 12PR L2	360-2533
ENGINE AR	430-3038
JUMPER LINES, 3RD FUNCTION	441-3367
WARNING, BEACON, LED STROBE	333-1425
PRODUCT LINK, SATELLITE PL631	454-0590
ENVIRONMENT, STANDARD	430-2855
KIT,SERIALIZED TECHNICAL MEDIA	0P-2491
SHIPPING/STORAGE PROTECTION	0P-2266
LANE 2 ORDER	0P-9002
PACK, DOMESTIC TRUCK	0P-0210
WEATHER, COLD START 120V	454-0610
QUICK COUPLER, FUSION	430-2977
BUCKET, GP, 2.7 YD3, FUS	360-3320
CUTTING EDGE, BOLT ON(4 PIECE)	8E-4566
FORK TINE, 2.6" X 5" X 54"	195-6938
CARRIAGE FUSION, FORK 60"	345-2415
ARM, MATERIAL HANDLING	289-9888

QUICK COUPLER, FUSION



BUCKET, GP, 2.70 YD3, HO



54" PALLET FORKS

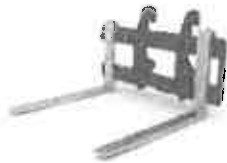

MATERIAL HANDLING ARM



2016 Caterpillar List Price	\$210,322.00
Ext Warranty	\$1,850.00
FREIGHT & DEALER PREP	\$1,060.00
SERVICE & PARTS MANUALS	\$1,190.00
IPA GOVERNMENTAL DISCOUNT	(\$66,922.00)
SALES TAX EXEMPT (0%)	\$0.00
After Tax Balance	\$147,500.00

INCLUDED WARRANTIES

- Standard Warranty: 12 Months/Unlimited Hours Full Machine.
- Extended Warranty: 36 MO / 5000 HR POWERTRAIN & HYDRAULIC (TIER IV)

F.O.B./TERMS

City of Darien Public Works Yard

ADDITIONAL CONSIDERATIONS

- Delivery is out of our Inventory and subject to prior sale

Accepted by _____ on _____

Signature



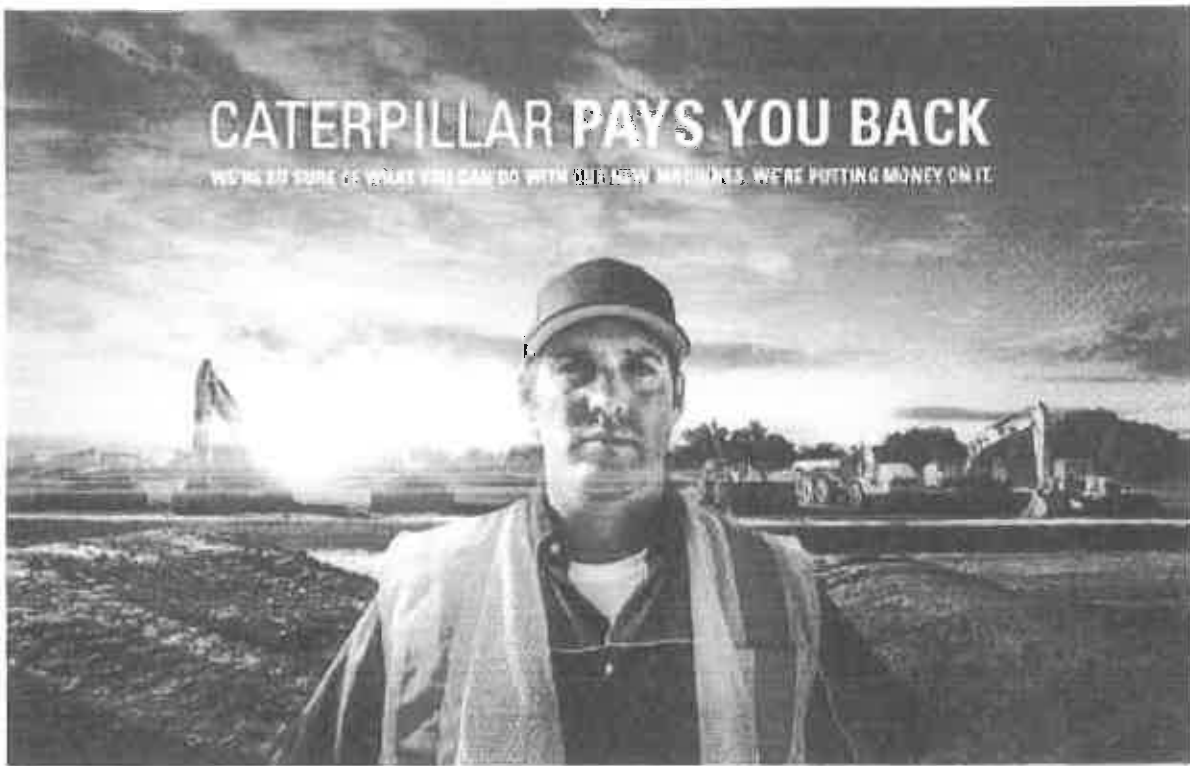

CATERPILLAR PAYS YOU BACK

WE'RE SO SURE OF WHAT YOU CAN DO WITH OUR NEW MACHINES, WE'RE PUTTING MONEY ON IT.

SPECIAL OFFER ON 100+ ELIGIBLE NEW CAT® MACHINES NOW UNTIL DECEMBER 31, 2015

FUEL CONSUMPTION GUARANTEE

Your new machine's fuel consumption is guaranteed to meet the performance standards set by Caterpillar. If it doesn't, we'll buy you a credit for the amount of fuel you've used. And we'll quickly credit you for the amount of fuel you've used. At the end of each year, if your credit has been used to the point where you can't get a credit, we'll give you a credit for the amount of fuel you've used.

EMISSIONS FLEET REPORTS

Track machine and engine emissions to help reduce carbon footprint. Our new machines provide you with real-time emissions data. You can see your data in real-time and make changes to help you reduce emissions and save money.

PARTS AVAILABILITY GUARANTEE

Get the parts you need to get your machine back to work. We guarantee that we'll have the parts you need to get your machine back to work. And, if they don't, we'll give you a credit for the amount of fuel you've used.

Call your dealer for more details.

BUILT FOR IT.

1-800-4-A-CATERPILLAR
 1-800-4-225-3777
 1-800-4-225-3777
 1-800-4-225-3777



RESOLUTION NO. _____

A RESOLUTION AUTHORIZING THE MAYOR AND CITY CLERK TO ACCEPT A PROPOSAL FROM PATTEN CAT FOR THE PURCHASE OF ONE (1) NEW 2016 CATERPILLAR LOADER MODEL NO 926M SMALL WHEEL LOADER IN AN AMOUNT NOT TO EXCEED \$147,500

BE IT RESOLVED BY THE CITY COUNCIL OF THE CITY OF DARIEN, DU PAGE COUNTY, ILLINOIS, as follows:

SECTION 1: The City Council of the City of Darien hereby authorizes the Mayor and City Clerk to accept a proposal from Patten Cat for the purchase of one (1) new 2016 Caterpillar Loader Model No 926M Small Wheel Loader in amount not to exceed \$147,500.00, a copy of which is attached hereto as "**Exhibit A**".

SECTION 2: This Resolution shall be in full force and effect from and after its passage and approval as provided by law.

PASSED BY THE CITY COUNCIL OF THE CITY OF DARIEN, DU PAGE COUNTY, ILLINOIS, this 2nd day of May, 2016.

AYES: _____

NAYS: _____

ABSENT: _____

APPROVED BY THE MAYOR OF THE CITY OF DARIEN, DU PAGE COUNTY, ILLINOIS, this 2nd day of May, 2016.

KATHLEEN MOESLE WEAVER, MAYOR

ATTEST:

JOANNE E. RAGONA, CITY CLERK

APPROVED AS TO FORM

CITY ATTORNEY



Quote 112404-01

March 25, 2016

CITY OF DARIEN/PUBLIC WORKS
1702 PLAINFIELD ROAD
DARIEN
Illinois
60561

Attention: KRIS THROM

Dear Kris,

We would like to thank you for your interest in our company and our products, and are pleased to quote the following for your consideration.

CATERPILLAR Model: 926M SMALL WHEEL LOADER

**ASK ABOUT THE "CAT PAYS YOU BACK" FUEL CONSUMPTION REBATE PROGRAM FOR THIS MACHINE
(PLEASE SEE ATTACHED BROCHURE)**

STOCK NUMBER: X5057 SERIAL NUMBER: 0LTE01912 YEAR: 2016

We wish to thank you for the opportunity of quoting on your equipment needs. This quotation is valid for 30 days, after which time we reserve the right to re-quote. If there are any questions, please do not hesitate to contact me. In closing, we do greatly appreciate this opportunity to earn your business. We are confident that our products, backed by our unparalleled product support after the sale, will exceed your expectations.

Sincerely,

Pete Swanson

Pete Swanson
Machine Sales Representative

CATERPILLAR Model: 926M SMALL WHEEL LOADER**STANDARD EQUIPMENT**

POWERTRAIN -Axle seal guards -Auto Idle shut down feature -Cat C7.1ACERT engine --Power Modes (Standard and Performance) --Power by Range (High Power in Range 4) --Tier 4 Final/Stage IV compliant --Turbocharged and after cooled --Filtered crankcase breather --Diesel particulate filter --Selective Catalyst Reduction --Coolant protection to -34C (-29F) --Differential lock in front axle --Dry type air cleaner --Enclosed wet disc full hydraulic brakes --Fuel priming pump, automatic --Fuel water separator --Hydraulically driven demand cooling fan --Hydrostatic transmission with electronic --controls --Operator Modes (Default, TC, Hydrostat and --Ice) --Directional Shift Aggressiveness (Fast, --Medium, Slow) --Rim pull control, adjust wheel torque --Creeper control, adjust ground speed --Lubed for life driveshaft's --Parking brake, electric --Ingle plane cooling package wide 6 fins --per inch density --S-O-S port, engine, coolant, transmission oil

HYDRAULICS --Automatic lift and bucket kick outs, --adjustable in-cab --Bucket and Fork Modes, adjustable in-cab --Cylinder damping at Kickout and --mechanical end stops --Fine Mode control (Fast, Medium, Slow) --in Fork Mode --Hydraulic Response setting (Fast, --Medium, Slow) --Hydraulic diagnostic connectors and --S-O-S ports --Hydraulic sight gauge, visible --Load sensing hydraulics and steering --Seat mounted hydraulic joystick controls

ELECTRICAL --Alternator, 115-amp, heavy duty --12V power supply in cab (2) --Batteries, 1,000 CCA (2) 24 volt system, --disconnect switch --Back up alarm --Emergency shutdown switch --Halogen work lights front and rear, LED --rear stop and turn lights --Heavy duty gear reduction starter --Product Link PRO w/3 year subscription --Remote jump start post --Resettable main and critical function --breakers --Roading lights front and rear

OPERATOR ENVIRONMENT --75 mm (3 in) retractable seatbelt --Automatic temperature control --Cab, enclosed ROPS/FOPS pressurized --and sound suppressed --Cup holders --External heated mirrors with lower --parabolic --Ground level cab door release --Gauges: -- Digital hour meter, odometer and --tachometer -- Digital ground speedometer and --direction indicator -- Engine coolant temperature gauge -- Fuel and Diesel Exhaust Fluid level -- indicator -- Hydraulic oil temperature gauge --Hydraulic control lockout --Interior cab lighting, door and dome --Interior rearview mirrors (2) --Lunch box storage --Operator warning system indicators --Radio ready speakers --Rear window defrost, electric --Seat mounted electronic implement --controls, adjustable --Sliding glass on the side windows --Column mounted multi function control --lights, wipers, turn signal --Suspension seat, fabric --Tilt and telescope steering wheel --Tinted front glass --Wet arm wiper/washer, 2-speed and --intermittent, front --Wet arm wiper washer, rear --Large-access enclosure doors with

OTHER STANDARD EQUIPMENT --Large-access enclosure doors with --adjustable close/open force --Parallel lift loader linkage --Recovery hitch with pin --Remote mounted lubrication points --Vandalism protection-- lockable compartments



MACHINE SPECIFICATIONS

Description	Reference No
926M WHEEL LOADER	430-2805
FENDERS, STANDARD	366-8148
CAB, DELUXE	423-7162
SEAT, DELUXE	423-7201
STEERING, STANDARD	430-2998
DIFFERENTIAL, OPEN REAR	333-6528
HYD,3V,COUPLER READY,STD LIFT	430-2823
COUNTERWEIGHT, HEAVY	348-2579
RIDE CONTROL	430-2859
RADIO, BLUETOOTH, AUX, MIC	372-1868
TIRES,20.5/25 FS SGGLD 12PR L2	360-2533
ENGINE AR	430-3038
JUMPER LINES, 3RD FUNCTION	441-3367
WARNING, BEACON, LED STROBE	333-1425
PRODUCT LINK, SATELLITE PL631	454-0590
ENVIRONMENT, STANDARD	430-2855
KIT,SERIALIZED TECHNICAL MEDIA	0P-2491
SHIPPING/STORAGE PROTECTION	0P-2266
LANE 2 ORDER	0P-9002
PACK, DOMESTIC TRUCK	0P-0210
WEATHER, COLD START 120V	454-0610
QUICK COUPLER, FUSION	430-2977
BUCKET, GP, 2.7 YD3, FUS	360-3320
CUTTING EDGE, BOLT ON(4 PIECE)	8E-4566
FORK TINE, 2.5" X 5" X 54"	195-6938
CARRIAGE FUSION, FORK 60"	345-2415
ARM, MATERIAL HANDLING	289-9888

QUICK COUPLER, FUSION



BUCKET, GP, 2.70 YD3, HO



54" PALLET FORKS



MATERIAL HANDLING ARM

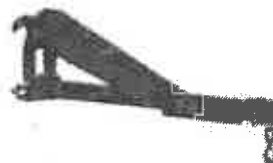

2016 Caterpillar List Price	\$210,322.00
Ext Warranty	\$1,850.00
FREIGHT & DEALER PREP	\$1,060.00
SERVICE & PARTS MANUALS	\$1,190.00
IPA GOVERNMENTAL DISCOUNT	(\$66,922.00)
SALES TAX EXEMPT (0%)	\$0.00
After Tax Balance	\$147,500.00

INCLUDED WARRANTIES

- Standard Warranty: 12 Months/Unlimited Hours Full Machine
- Extended Warranty: 36 MO / 5000 HR POWERTRAIN & HYDRAULIC (TIER IV)

F.O.B./TERMS

City of Darien Public Works Yard

ADDITIONAL CONSIDERATIONS

- Delivery is out of our inventory and subject to prior sale

Accepted by _____ on _____

Signature



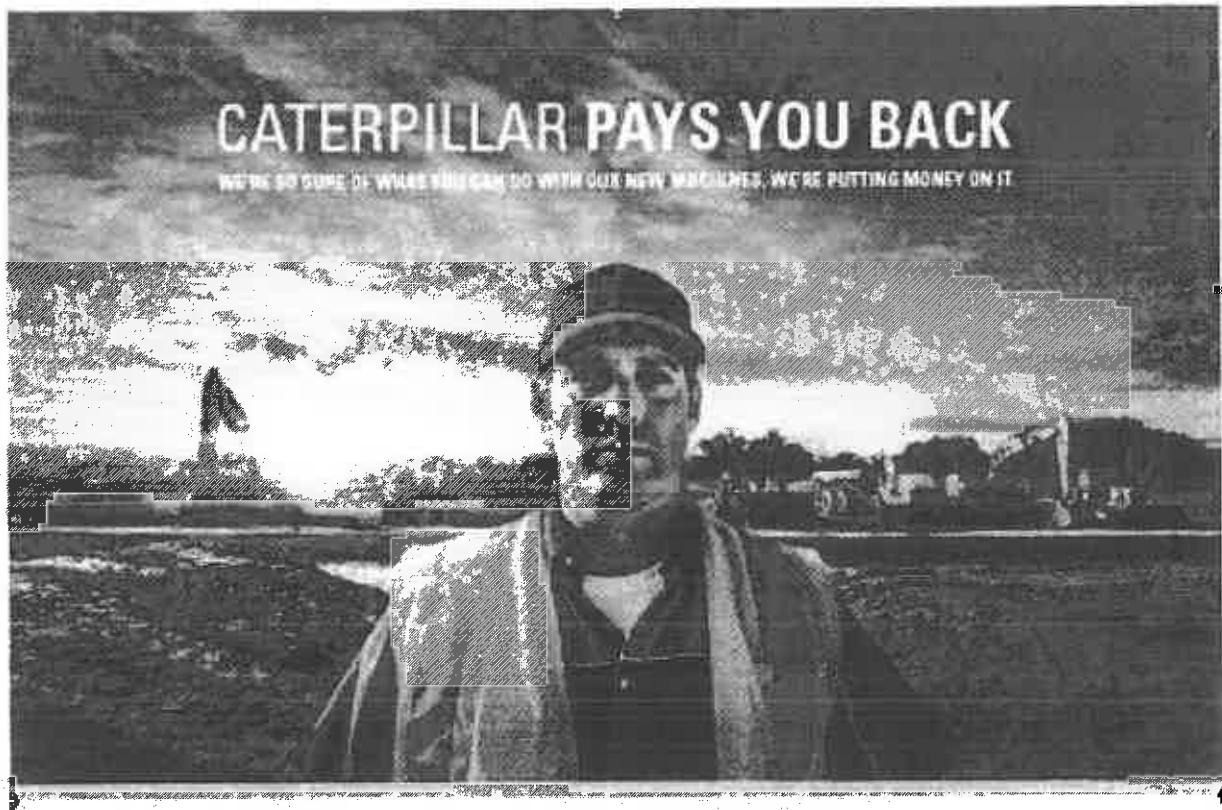

CATERPILLAR PAYS YOU BACK

WE'RE SO SURE OF WHAT YOU CAN DO WITH OUR NEW MACHINES, WE'RE PUTTING MONEY ON IT

SPECIAL OFFER ON 100+ ELIGIBLE NEW CAT® MACHINES NOW UNTIL DECEMBER 31, 2015

FUEL CONSUMPTION GUARANTEE

Your new high-horsepower engine fuel consumption rate is guaranteed for three years or 4,000 hours, whichever comes first. For three years or 4,000 hours, whichever comes first, we'll track your actual fuel consumption. If it exceeds your actual fuel consumption by Cat® Fueler™, we'll send quarterly credits covering the difference. At the end of each year, if your actual fuel consumption exceeds the guaranteed rate, you'll get a credit of 1.00 gallon or 1 CAT® in the form of a Cat Financial Commercial Account Card.

EMISSIONS FLEET REPORTS

Track emissions and operator behavior to reduce idle times, decrease fuel costs, and improve fleet efficiency. Fleet reports and relevant data from your machines' Fueler™ Link™—powered by the on-machine, intelligent, real-time, operator behavior engine and sensors. You can compare your data to industry benchmarks and make changes to boost operator, machine and overall machine-to-asset efficiency.

PARTS AVAILABILITY GUARANTEE

Get the parts you need within 24 hours or your shipping fee is free. With the Cat® PartsDirect™ and your parts right away, you'll spend less, more time in possession of the parts you need you need way to you in 24 hours or less. And, if they don't get them in 24 hours—shipping is FREE. As part of the program, other Cat equipment in your fleet can be registered for the parts availability guarantee.

Talk to your dealer for more details.

BUILT FOR IT.

©2015 Caterpillar. All rights reserved. CAT, Fueler, Link, and PartsDirect are trademarks of Caterpillar Inc. All other trademarks are the property of their respective owners. Fleet reports and relevant data from your machines' Fueler™ Link™—powered by the on-machine, intelligent, real-time, operator behavior engine and sensors. You can compare your data to industry benchmarks and make changes to boost operator, machine and overall machine-to-asset efficiency.



AGENDA MEMO
Municipal Services Committee
April 25, 2016

ISSUE STATEMENT

Approval of a resolution accepting a proposal from Decker Supply Company Inc. for the purchase of Telespar Sign Posts, Anchors and Rain Caps in an amount not to exceed \$5,963.36.

BACKGROUND/HISTORY

The proposed sign posts would be utilized to replace 200 existing channel poles that are deteriorated throughout the City.

Below please find the results of three competitive quotes for the equipment.

VENDOR	COST
Custom Products	\$ 7,568.79
<i>Decker Supply Co. Inc</i>	<i>\$ 5,963.36</i>
Traffic Control and Protection	\$ 7,130.00

The proposed expenditure would be expended from the following line account:

ACCOUNT NUMBER	ACCOUNT DESCRIPTION	FY16-17 BUDGET	PROPOSED EXPENDITURE	PROPOSED BALANCE
01-30-4257	SUPPLIES-SIGNS AND ACCESSORIES	\$10,000	\$ 5,963.36	\$ 4,036.64

STAFF RECOMMENDATION

Staff recommends approval of a resolution accepting a proposal from Decker Supply Company Inc. for the purchase of Telespar Sign Posts, Anchors and Rain Caps in an amount not to exceed \$5,963.36.

ALTERNATE DECISION

As recommended by the Committee.

DECISION MODE

This item will be on the May 2, 2016 City Council agenda for formal consideration.

RESOLUTION NO. _____

A RESOLUTION AUTHORIZING THE MAYOR AND CITY CLERK TO ACCEPT A PROPOSAL FROM DECKER SUPPLY COMPANY, INC. FOR THE PURCHASE OF TELES PAR SIGN POSTS, ANCHORS, AND RAIN CAPS IN AN AMOUNT NOT TO EXCEED \$5,963.36

BE IT RESOLVED BY THE CITY COUNCIL OF THE CITY OF DARIEN, DU PAGE COUNTY, ILLINOIS, as follows:

SECTION 1: The City Council of the City of Darien hereby authorizes the Mayor and City Clerk to accept a proposal from Decker Supply Company, Inc. for the purchase of Telespar sign posts, anchors, and rain caps in an amount not to exceed \$5,963.36, a copy of which is attached hereto as "**Exhibit A**".

SECTION 2: This Resolution shall be in full force and effect from and after its passage and approval as provided by law.

PASSED BY THE CITY COUNCIL OF THE CITY OF DARIEN, DU PAGE COUNTY, ILLINOIS, this 2nd day of May, 2016.

AYES: _____

NAYS: _____

ABSENT: _____

APPROVED BY THE MAYOR OF THE CITY OF DARIEN, DU PAGE COUNTY, ILLINOIS, this 2nd day of May, 2016.

KATHLEEN MOESLE WEAVER, MAYOR

ATTEST:

JOANNE E. RAGONA, CITY CLERK

APPROVED AS TO FORM

CITY ATTORNEY



1115 O'Neill Ave.
 P.O. Box 8008
 Ph: 1-217-825-9369
 Fax: 1-217-824-5779

Quotation

Date	Quote #
11/25/2015	4321

Bill To
City of Darien 1702 Plainfield Darien, IL 60561

Ship To
City of Darien 1041 S. Frontage Rd. Darien, IL 60561 Jeff 630-514-5605

P.O. #	FOB	SHIP VIA	Contract	REP		
			Jeff	BB		
DESCRIPTION			Weight	QTY	PRICE	Total
2.25" x 2.25" x 3' 12 ga. Telespar Anchor			8.38	200	8.32	1,664.00
2.00" x 2.00" x 10' 14 ga. Telespar Posts			19.89	200	18.65	3,730.00
Pyramid Rain Cap for 2" Telespar			.20	200	2.10	420.00
Shipping and Handling				1	149.36	149.36
Customer Phone		Customer Fax		<i>Quote good for 30 days.</i>		Total 35,963.36
630-353-8105		630-852-4709				

Thank you for your business!



Traffic Control & Protection Inc

31W351 North Ave
West Chicago, IL 60185

Phone 630-293-8026 Fax 630-293-0029

Quote

Date	Quote #
4/4/2016	12905

Name / Address
City of Darien 1041 S Frontage Rd Darien IL 60561

Ship To
City of Darien Attn: Jeff/Dave (e-mail both for approval) 1041 S Frontage Rd Darien, IL 60561

Terms	Rep	FOB	Shipping Method	Estimated Ship Date
Net 30	LMH	Darien	Our Truck	

Item	Description	Qty	Cost	Total
TP20010	Telspar Post 2.00" 14GA 10'	200	20.50	4,100.00
TP22503	Telspar Anchor 2.25" 12GA 3'	200	10.65	2,130.00
2PRC	Pyramid Rain Cap for 2" post	200	3.25	650.00
TL070	5/16 Turner bolt for 2 1/4" Anchor w/Flanged Nut	200	1.25	250.00
** No Charge Shipping**				

This is a quote only. Please DO NOT remit payment. Thank you.

Orders for custom products cannot be cancelled or returned once order has been placed. TCP has a 30 day return policy on all products that we sell. Please call ahead for approval on any returns. Standard restocking charge is 25%.

Total	\$7,130.00
--------------	-------------------

Signature _____

Quotation Number B291301-A

Quote Date 04/04/16

Custom Products Corporation
 P.O. Box 54091
 Jackson, MS 39288-4091

Telephone: 601/932-5854

Bill To:
 City of Darlen
 1702 Plainfield Rd
 City of Darlen
 Darlen, IL 60561

Ship To:
 City of Darlen
 1041 South Frontage Road
 Darlen, IL 60561

THIS IS A BID/ESTIMATE

Customer	Ship Via	F.O.B.	Terms	Purchase Order Number	Salesperson	Reference No.	
DARIL	Quoted frt	Origin	Net 30 Days	Quote square post	HM		
Qty Quoted	Qty Shipped	Item Number	Description	Unit of Measure	Reqd Date	Unit Price	Extended Price
	Back Ordered					Excl % Tax	
200		0 RPOSG10142	POST SQUARE GALVANIZED 10FT 2X2 14 GA STOCK ITEM (25/BDL) [F]	EA	04/04/16	23.1100	4622.00
200		0 RPOSG0312225	POST SQUARE GALV 3FT(36")2.25X2.25 12GA(BRWY BASE FOR 2"POST(25/BDL)[F]	EA	04/04/16	10.3800	2072.00
200		0 RHBCORNERBOLT25	CORNER BOLT FOR SQUARE POST UP TO 2.5" (INCUDLES NUT) VCB240-2.5 [F] STOCK ITEM	EA	04/04/16	0.8400	168.00
1		0 FREIGHT	FREIGHT per tg	EA	04/04/16	706.7900	706.79
				SHIP & BACKORDER YES OR NO			
- Quotes expire 30 days from the quoted date unless otherwise noted above. - Please refer to our catalog for terms of sale, ordering and artwork guidelines. - The "C.A.L.T." is our estimated current average lead time based on historical information.							
						Non Taxable Subtotal	7568.79
						Taxable Subtotal	0.00
						Tax	0.00
						Total Order	7568.79

AGENDA MEMO
Municipal Services Committee
April 25, 2016

ISSUE STATEMENT

A **resolution** authorizing the purchase of one new 2016 Hydraulic Hammer-WT Hamr Work Tool attachment from Patten Cat in an amount not to exceed \$23,780.

BACKGROUND/HISTORY

The proposed hammer is an attachment for the backhoe and is utilized for breaking out asphalt and concrete. The proposed equipment would be replacing a 1990 JACT Hydraulic Breaker. The jackhammer has served its useful life. The existing hammer will be declared as surplus and a separate agenda memo will be presented at a later date for City Council approval.

Staff has selected Patten Cat to supply the jackhammer attachment and is the awarded vendor for the National Intergovernmental Purchasing Alliance-National IPA City of Darien Participation Agency Member No. 228633, for equipment sales to municipalities nationally. Attached and labeled as **Attachment A**, pages 1-8 is information regarding National IPA. Attached and labeled as **Attachment B** is the cost breakdown and specifications for the 2016 Hydraulic Hammer.

The proposed expenditure would be expended from the following line account:

ACCOUNT NUMBER	ACCOUNT DESCRIPTION	FY 16-17 BUDGET	PROPOSED EXPENDITURE	PROPOSED BALANCE
02-50-4815	CAPITAL PURCHASES CONCRETE HYDRAULIC BREAKER	\$23,615	\$ 23,780	\$ (165.00)

STAFF RECOMMENDATION

Staff recommends approval of the resolution authorizing the purchase of one new 2016 Hydraulic Hammer-WT Hamr Work Tool attachment from Patten Cat in an amount not to exceed \$23,780.

ALTERNATE DECISION

As recommended by the Committee.

DECISION MODE

This item will be on the May 2, 2016 City Council agenda for formal consideration.



**Heavy Equipment, Parts, Accessories, Supplies & Related Services
Executive Summary**

Lead Agency: City of Tucson, AZ
RFP Issued: October 18, 2011
Date Open: November 14, 2011

Solicitation: RFP #120377
Pre-Proposal Date: October 27, 2011
Proposals Received: 4

Awarded to: Caterpillar

The City of Tucson, AZ Department of Procurement issued RFP #120377 on October 18, 2011 to establish a national cooperative contract for heavy equipment, parts, accessories, supplies and related services.

Notice of the solicitation was sent to potential offerors, as well as advertised in the following:

- City of Tucson, AZ website
- Hawaii Tribune-Herald, HI
- Daily Journal of Commerce, OR
- The State, SC
- The Olympian, WA
- National IPA website

On November 14, 2011 proposals were received from the following offerors:

- Badger Equipment Company
- Caterpillar
- Federal Contracts Corporation
- PB Loader Corporation

The proposals were evaluated by an evaluation committee. Using the evaluation criteria established in the RFP, the committee elected to enter into interview and negotiations with the top ranked firm, Caterpillar.

The City of Tucson, AZ, National IPA and Caterpillar successfully negotiated a contract and the City of Tucson executed the agreement with a contract effective date of May 2, 2012.

Caterpillar

Contract includes: Heavy equipment, parts, accessories, supplies and related services

Term:

Initial one year agreement from May 2, 2012 through May 1, 2013, with option to renew for four (4) additional one-year periods through May 1, 2017.

Pricing/Discount:

Minimum discount off list price.

Serviced and supported by local Cat dealers.

Value Added Services:

- Financing options
- Used equipment
- Rentals
- Extended warranties
- Maintenance agreements
- Trade-in or Buyback options

Caterpillar Product and Service Pricing

<u>Model</u>	<u>Minimum Member Discount</u>
Articulated Trucks	14%
Backhoe Loaders	21%
Generators	17% - 50%
Integrated Tool Carriers	21% - 26%
Landfill Compactors	14%
Motor Graders	23% - 37%
Paving Products	14% - 18%
Skid Steer Loaders	16%
Towed Scrapers	15%
Track Excavators	12% - 25%
Track Loaders	20% - 23%
Track Type Tractors	10% - 25%
Tractor Scrapers	15% - 17%
Vocational Trucks	23%
Wheel Dozers	15%
Wheel Loaders	12% - 26%
Wheeled Excavators	32% - 35%
Work tools	15%

The following items are also available under the contract:

- Financing Options
- Used Equipment - subject to availability, 20% discount off the original list price of used Caterpillar equipment that is currently in the Cat Dealers rental fleet, excluding vocational trucks and work tools
- Used Vocational Trucks & Work Tools - pricing to be negotiated with local participating dealer
- Rentals - product and service pricing to be negotiated with local participating dealer
- Accessories/Allied Products (trailers, etc.) - product pricing to be negotiated with local participating dealer
- Parts - product pricing to be negotiated with local participating dealer
- Service/Repair - product pricing to be negotiated with local participating dealer
- Extended Warranties - product pricing to be negotiated with local participating dealer
- Maintenance Agreements - product pricing to be negotiated with local participating dealer
- Trade-In or Buyback Options - to be negotiated with local participating dealer

2015 Caterpillar Coop Contract Discounts V6

Machines	New Equipment	Used Equipment
2015	Discount off List	Discount from original List
Pavers		
AP255	16.00%	20.0%
AP500	16.00%	20.0%
AP555	16.00%	20.0%
AP600	16.00%	20.0%
AP655	16.00%	20.0%
AP1000	16.00%	20.0%
AP1055	16.00%	20.0%
Rollers		
CB14	16.00%	20.0%
CB22	16.00%	20.0%
CB24	16.00%	20.0%
CB32	16.00%	20.0%
CB34/CB34XW	16.00%	20.0%
CB44	16.00%	20.0%
CB54	16.00%	20.0%
CB64	16.00%	20.0%
CC24	16.00%	20.0%
CC34	16.00%	20.0%
CD44	16.00%	20.0%
CD54	16.00%	20.0%
CP34	14.00%	20.0%
CP44	14.00%	20.0%
CP54	14.00%	20.0%
CP56	14.00%	20.0%
CP68	14.00%	20.0%
CP74	14.00%	20.0%
CS34	14.00%	20.0%
CS44	14.00%	20.0%
CS54	14.00%	20.0%
CS64	14.00%	20.0%
CS68	14.00%	20.0%
CS78	14.00%	20.0%
CW14	16.00%	20.0%
CW34	16.00%	20.0%
Vocational Trucks		
CT660	23.00%	20.0%
CT680	23.00%	20.0%
CT681	23.00%	20.0%

2015 Caterpillar Coop Contract Discounts V6

Track Type Tractors		
D3	25.00%	20.0%
D4	24.00%	20.0%
D5	25.00%	20.0%
D6	24.00%	20.0%
D7	22.00%	20.0%
D8	22.00%	20.0%
D9	10.00%	20.0%
Integrated Tool Carriers		
IT62	21.00%	20.0%
Cold Planners		
PM102	14.00%	20.0%
PM200	14.00%	20.0%
PM201	18.00%	20.0%
Reclaimers		
RM300	14.00%	20.0%
RM500	14.00%	20.0%
Wheeled Excavators		
M313	35.00%	20.0%
M314	18.00%	20.0%
M315	32.00%	20.0%
M316	35.00%	20.0%
M318	32.00%	20.0%
M320	21.00%	20.0%
M322	35.00%	20.0%
Motor Graders		
12	33.00%	20.0%
120	37.00%	20.0%
140	33.00%	20.0%
160	33.00%	20.0%
14	23.00%	20.0%

2015 Caterpillar Coop Contract Discounts V6

Skid Steer Loaders		
226	16.00%	20.0%
232	16.00%	20.0%
236	16.00%	20.0%
242	16.00%	20.0%
246	16.00%	20.0%
262	16.00%	20.0%
272	16.00%	20.0%
Multi-Terrain Loaders		
247	16.00%	20.0%
257	16.00%	20.0%
277	16.00%	20.0%
287	16.00%	20.0%
297	16.00%	20.0%
Compact Track Loaders		
239	16.00%	20.0%
249	16.00%	20.0%
259	16.00%	20.0%
279	16.00%	20.0%
289	16.00%	20.0%
299	16.00%	20.0%
Excavators		
300.9	17.50%	20.0%
301.4	17.50%	20.0%
301.7	17.50%	20.0%
302.4	17.50%	20.0%
302.7	17.50%	20.0%
303	17.50%	20.0%
303.5	17.50%	20.0%
304	17.50%	20.0%
305	17.50%	20.0%
305.5	17.50%	20.0%
308	17.50%	20.0%
311	24.00%	20.0%
312	21.00%	20.0%
313	21.00%	20.0%
314	25.00%	20.0%
316	25.00%	20.0%
318	22.00%	20.0%
319	22.00%	20.0%
320	18.00%	20.0%
321	18.00%	20.0%
323	18.00%	20.0%

2015 Caterpillar Coop Contract Discounts V6

324	18.00%	20.0%
325	18.00%	20.0%
328	18.00%	20.0%
329	18.00%	20.0%
335	18.00%	20.0%
336	18.00%	20.0%
345	12.00%	20.0%
349	12.00%	20.0%
352	12.00%	20.0%
374	10.00%	20.0%
Backhoe Loaders		
416	21.00%	20.0%
420	21.00%	20.0%
430	21.00%	20.0%
450	21.00%	20.0%
Wheel Tractor Scrapers		
621	16.00%	20.0%
623	17.00%	20.0%
627	16.00%	20.0%
Articulated Trucks		
725	14.00%	20.0%
730	14.00%	20.0%
735	14.00%	20.0%
740	14.00%	20.0%
745	14.00%	20.0%
Rigid Frame Trucks		
770	10.00%	20.0%
773	10.00%	20.0%
Landfill Compactors		
815	14.00%	20.0%
816	14.00%	20.0%
825	14.00%	20.0%
826	14.00%	20.0%
836	14.00%	20.0%
Wheel Dozers		
814	15.00%	20.0%
824	15.00%	20.0%

2015 Caterpillar Coop Contract Discounts V6

Wheel Loaders		
903	25.00%	20.0%
906	25.00%	20.0%
907	25.00%	20.0%
908	25.00%	20.0%
910	25.00%	20.0%
914	25.00%	20.0%
924	26.00%	20.0%
930	26.00%	20.0%
938	26.00%	20.0%
950	24.00%	20.0%
962	24.00%	20.0%
966	21.00%	20.0%
972	16.00%	20.0%
980	12.00%	20.0%
982	12.00%	20.0%
Track Loaders		
953	20.00%	20.0%
963	23.00%	20.0%
973	23.00%	20.0%
Telehandlers		
TH255	12.00%	20.0%
TH406	12.00%	20.0%
TH407	12.00%	20.0%
TH514	12.00%	20.0%
TL642	12.00%	20.0%
TL943	12.00%	20.0%
TL1055	12.00%	20.0%
TL1255	12.00%	20.0%
Worktools	15.00%	
Caterpillar Safety Services	15.00%	N/A



Quote 112450-01

April 1, 2016

CITY OF DARIEN/PUBLIC WORKS
1702 PLAINFIELD ROAD
DARIEN
Illinois
60561

Attention: KRIS THROM

Dear Kris,

We would like to thank you for your interest in our company and our products, and are pleased to quote the following for your consideration.

ASK YOUR SALESMAN ABOUT OUR "MARCH MADNESS INVENTORY REDUCTION SALE"
<http://www.pattencat.com/pdf/inventoryreductionsale.pdf>

CATERPILLAR Model: WT HAMR WORK TOOL

STOCK NUMBER: TBO SERIAL NUMBER: TBO YEAR: 2016

We wish to thank you for the opportunity of quoting on your equipment needs. This quotation is valid for 30 days, after which time we reserve the right to re-quote. If there are any questions, please do not hesitate to contact me. In closing, we do greatly appreciate this opportunity to earn your business. We are confident that our products, backed by our unparalleled product support after the sale, will exceed your expectations.

Sincerely,

Pete Swanson

Pete Swanson
Machine Sales Representative

CATERPILLAR Model: WT HAMR WORK TOOL



MACHINE SPECIFICATIONS

Description	Reference No
WORK TOOLS, HAMMERS	0P-2364
H95E S HAMMER	369-0786
TOOL, MOIL	369-0792
BRACKET, MOUNTING (QC)-PIN LOCK	416-8031
LINES, CONNECTOR	399-6964

2016 Caterpillar List Price	\$30,886.00
FREIGHT & DEALER PREP	\$780.00
IPA GOVERNMENTAL DISCOUNT	(\$7,886.00)
SALES TAX EXEMPT. (0%)	\$0.00
After Tax Balance	\$23,780.00

WARRANTY

Standard Warranty: 12 Months/Unlimited Hours Full Tool

F.O.B./TERMS

Elmhurst Tractor

ADDITIONAL CONSIDERATIONS

- Delivery Is 2-3 weeks

Accepted by _____ on _____

Signature



Lisa Klemm

From: Pete Swanson <swansonp@pattencat.com>
Sent: Thursday, April 07, 2016 2:02 PM
To: Dan Gombac
Cc: Kris Throm; Lisa Klemm
Subject: Re: 2016 Hydraulic Hammer

Great, keep me informed.

Thank you,

Pete N. Swanson
Patten Cat
Machine Sales Rep.
(M)630-936-0626
(F)630-279-0121

swansonp@pattencat.com

On Apr 7, 2016, at 2:00 PM, "Dan Gombac" <dgombac@darienil.gov> wrote:

Thanks Pete and Kris, I will revise the cost on the quote and use this e-mail as the backup.

Daniel Gombac
Director of Municipal Services
630-353-8106

To receive important information from the City of Darien
sign up for our electronic newsletter:

DARIEN DIRECT CONNECT

Follow the link below and subscribing is simple!

[http://www.darien.il.us/Departments/Administratio
n/CityNews.html](http://www.darien.il.us/Departments/Administratio
n/CityNews.html)

From: Kris Throm
Sent: Thursday, April 07, 2016 1:04 PM
To: Dan Gombac <dgombac@darienil.gov>
Subject: FW: 2016 Hydraulic Hammer

Dan,

See below from Pete at Patten. They can make the slightly lower price work to meet our budget number.

Thanks,

Kris Throm

City of Darien Municipal Services
Water Department Foreman
(630) 514-3453

Please sign up for Darien Direct Connect Newsletter, the best way to receive current information for the community. Just click on this link and enter your e-mail address!

<http://www.darien.il.us/Departments/Administration/CityNews.html>

From: Pete Swanson [<mailto:swansonp@pattencat.com>]

Sent: Thursday, April 07, 2016 12:58 PM

To: Kris Throm <kthrom@darienil.gov>

Subject: RE: 2016 Hydraulic Hammer

Kris,

Must have been, I can make the \$23,615 price work.

Pete Swanson

Machine Sales Representative

635 W. Lake Street | Elmhurst, IL 60126

Cell: 630-936-0626

swansonp@pattencat.com | PattenCat.com

From: Kris Throm [<mailto:kthrom@darienil.gov>]

Sent: Thursday, April 07, 2016 11:12 AM

To: Pete Swanson

Subject: FW: 2016 Hydraulic Hammer

Pete,

Not sure if the price jumped up due to going through the NJPA, but is there any chance you can lower the price \$165.00 to meet our budget number for the breaker?

Thanks,

Kris Throm

City of Darien Municipal Services

Water Department Foreman

(630) 514-3453

Please sign up for Darien Direct Connect Newsletter, the best way to receive current information for the community. Just click on this link and enter your e-mail address!

<http://www.darien.il.us/Departments/Administration/CityNews.html>

RESOLUTION NO. _____

A RESOLUTION AUTHORIZING THE MAYOR AND CITY CLERK TO ACCEPT A PROPOSAL FROM PATTEN CAT FOR THE PURCHASE OF ONE (1) NEW 2016 HYDRAULIC HAMMER – WT HAMR WORK TOOL ATTACHMENT IN AN AMOUNT NOT TO EXCEED \$23,780

BE IT RESOLVED BY THE CITY COUNCIL OF THE CITY OF DARIEN, DU PAGE COUNTY, ILLINOIS, as follows:

SECTION 1: The City Council of the City of Darien hereby authorizes the Mayor and City Clerk to accept a proposal from Patten Cat for the purchase of one (1) new 2016 Hydraulic Hammer – WT HMR Work Tool attachment in an amount not to exceed \$23,780.00, a copy of which is attached hereto as “**Exhibit A**”.

SECTION 2: This Resolution shall be in full force and effect from and after its passage and approval as provided by law.

PASSED BY THE CITY COUNCIL OF THE CITY OF DARIEN, DU PAGE COUNTY, ILLINOIS, this 2nd day of May, 2016.

AYES: _____

NAYS: _____

ABSENT: _____

APPROVED BY THE MAYOR OF THE CITY OF DARIEN, DU PAGE COUNTY, ILLINOIS, this 2nd day of May, 2016.

KATHLEEN MOESLE WEAVER, MAYOR

ATTEST:

JOANNE E. RAGONA, CITY CLERK

APPROVED AS TO FORM

CITY ATTORNEY



Quote 112450-01

April 1, 2016

CITY OF DARIEN/PUBLIC WORKS
1702 PLAINFIELD ROAD
DARIEN
Illinois
60561

Attention: KRIS THROM

Dear Kris,

We would like to thank you for your interest in our company and our products, and are pleased to quote the following for your consideration.

ASK YOUR SALESMAN ABOUT OUR "MARCH MADNESS INVENTORY REDUCTION SALE"
<http://www.pattencat.com/pdf/Inventoryreductionsale.pdf>

CATERPILLAR Model: WT HAMR WORK TOOL

STOCK NUMBER: TBO SERIAL NUMBER: TBO YEAR: 2016

We wish to thank you for the opportunity of quoting on your equipment needs. This quotation is valid for 30 days, after which time we reserve the right to re-quote. If there are any questions, please do not hesitate to contact me. In closing, we do greatly appreciate this opportunity to earn your business. We are confident that our products, backed by our unparalleled product support after the sale, will exceed your expectations.

Sincerely,

Pete Swanson

Pete Swanson
Machine Sales Representative

CATERPILLAR Model: WT HAMR WORK TOOL



MACHINE SPECIFICATIONS

Description	Reference No
WORK TOOLS, HAMMERS	0P-2364
H95E S HAMMER	369-0786
TOOL, MOIL	369-0792
BRACKET, MOUNTING (QC)-PIN LOCK	416-8031
LINES, CONNECTOR	399-6964

2016 Caterpillar List Price	\$30,886.00
FREIGHT & DEALER PREP	\$780.00
IPA GOVERNMENTAL DISCOUNT	(\$7,886.00)
SALES TAX EXEMPT (0%)	\$0.00
After Tax Balance	\$23,780.00

WARRANTY

Standard Warranty: 12 Months/Unlimited Hours Full Tool

F.O.B/TERMS

Eimhurst Tractor

ADDITIONAL CONSIDERATIONS

- Delivery is 2-3 weeks

Accepted by _____ on _____

Signature



Lisa Klemm

From: Pete Swanson <swansonp@pattencat.com>
Sent: Thursday, April 07, 2016 2:02 PM
To: Dan Gombac
Cc: Kris Throm; Lisa Klemm
Subject: Re: 2016 Hydraulic Hammer

Great, keep me informed.

Thank you,

Pete N. Swanson
Patten Cat
Machine Sales Rep.
(M)630-936-0626
(F)630-279-0121

swansonp@pattencat.com

On Apr 7, 2016, at 2:00 PM, "Dan Gombac" <dgombac@darienil.gov> wrote:

Thanks Pete and Kris, I will revise the cost on the quote and use this e-mail as the backup.

Daniel Gombac
Director of Municipal Services
630-353-8106

To receive important information from the City of Darien
sign up for our electronic newsletter:

DARIEN DIRECT CONNECT

Follow the link below and subscribing is simple!

[http://www.darien.il.us/Departments/Administratio
n/CityNews.html](http://www.darien.il.us/Departments/Administratio
n/CityNews.html)

From: Kris Throm
Sent: Thursday, April 07, 2016 1:04 PM
To: Dan Gombac <dgombac@darienil.gov>
Subject: FW: 2016 Hydraulic Hammer

Dan,

See below from Pete at Patten. They can make the slightly lower price work to meet our budget number.

Thanks,

Kris Throm

City of Darien Municipal Services
Water Department Foreman
(630) 514-3453

Please sign up for Darien Direct Connect Newsletter, the best way to receive current information for the community. Just click on this link and enter your e-mail address!

<http://www.darien.il.us/Departments/Administration/CityNews.html>

From: Pete Swanson [<mailto:swansonp@pattencat.com>]
Sent: Thursday, April 07, 2016 12:58 PM
To: Kris Throm <kthrom@darienil.gov>
Subject: RE: 2016 Hydraulic Hammer

Kris,

Must have been, I can make the \$23,615 price work.

Pete Swanson
Machine Sales Representative
635 W. Lake Street | Elmhurst, IL 60126
Cell: 630-936-0626
swansonp@pattencat.com | PattenCat.com

From: Kris Throm [<mailto:kthrom@darienil.gov>]
Sent: Thursday, April 07, 2016 11:12 AM
To: Pete Swanson
Subject: FW: 2016 Hydraulic Hammer

Pete,

Not sure if the price jumped up due to going through the NJPA, but is there any chance you can lower the price \$165.00 to meet our budget number for the breaker?

Thanks,

Kris Throm
City of Darien Municipal Services
Water Department Foreman
(630) 514-3453

Please sign up for Darien Direct Connect Newsletter, the best way to receive current information for the community. Just click on this link and enter your e-mail address!

<http://www.darien.il.us/Departments/Administration/CityNews.html>

AGENDA MEMO
Municipal Services Committee
April 25, 2016

ISSUE STATEMENT

A resolution authorizing the Mayor to execute a contract with Denler Inc. in an amount not to exceed \$183,750 for the 2016 Crack Fill Program.

BACKGROUND/HISTORY

The FY 16/17 Budget includes funds for the 2016 Crack Fill Program. Crack sealing is a routine maintenance treatment that will significantly delay roadway deterioration. The sealing material is applied into the cracks before they become too large and before the freeze-thaw cycles have an opportunity to shift the pavement and develop larger cracks (alligating). Flexible rubberized asphalt sealants bond to crack walls and move with the pavement, preventing water from entering the road base. The life of the road is extended and maintenance costs greatly reduced over time.

The scope of the program includes all cracks to be routed with a low dust mechanical router to a depth of ½” and a width of approximately 3”. Upon completion of the routing, all dirt, debris, and water is removed from the cracks. The method of removal is completed by utilizing a blow pipe which blows compressed air from a pull behind conventional air compressor. The crack is then filled with a rubber sealant which is feathered to a width of approximately 3-inches in width.

This year the City of Darien teamed up with local public agencies which included Burr Ridge, Downers Grove, DuPage County, Lombard, Villa Park, West Chicago, Wheaton, and Woodridge and solicited competitive bids, collectively. Attached and labeled as Attachment A are the bid results from the bid opening held by the Village of Woodridge on March 31, 2016. The contract has two optional extensions for 2017 and 2018. Pending future budget allocations and workmanship, the extensions will be brought forth for formal approval in their respective years.

Attachment B is the list of roads scheduled for this year’s program. Denler Incorporated has completed crack filling in the past with satisfactory work.

The proposed Crack Sealing Program would be funded from the following FY6-17 Budget:

ACCOUNT NUMBER	ACCOUNT DESCRIPTION	FY 16-17 BUDGET	PROPOSED EXPENDITURE	PROPOSED BALANCE
25-35-4382	CRACK FILL PROGRAM	\$183,750.00	\$ 183,750	\$0

STAFF RECOMMENDATION

Staff recommends approval of the proposed resolution.

DECISION MODE

This item will be placed on the-May 2, 2016 City Council agenda for formal consideration.

PROJECT FILE NAME: CRACK SEALING AND SEAL COATING SERVICES
 PROJECT NO.: 2016-02

DATE: 3/31/2016
 TIME: 10:00 A.M.
 TABULATED BY: BWT

NO	ITEM	QUAN	UNIT	ENGINEER'S ESTIMATE		Denier, Inc. 19148 S. 104th Avenue Mokena, IL 60448		SKC Construction, Inc. PO Box 503 West Dundee, IL 60118		Behm Pavement Maintenance 3010 Route 176 Crystal Lake, IL 60014		Average Unit Price	
				UNIT PRICE	TOTAL	UNIT PRICE	TOTAL	UNIT PRICE	TOTAL	UNIT PRICE	TOTAL	UNIT PRICE	TOTAL
A	Crack Sealing Asphalt Pavement	589,875	LB	\$1.54	\$877,907.50	\$1.195	\$681,000.63	\$1.256	\$715,763.00	\$1.37	\$780,728.75	\$1.27	\$725,830.79
B	Crack and Joint Sealing PCC Pavement	1,275	LB	\$2.47	\$3,149.25	\$3.65	\$4,908.75	\$1.47	\$1,874.25	\$2.50	\$3,187.50	\$2.61	\$3,323.50
C	Fiber-Asphalt Crack Sealing Asphalt Pavement	93,500	LB	\$1.72	\$160,820.00	\$1.265	\$118,277.50	\$1.31	\$122,485.00	\$1.47	\$137,445.00	\$1.35	\$126,069.17
D	Seal Coat Bike Path	15,360	SY	\$1.12	\$17,203.20	\$0.78	\$11,980.80	\$0.87	\$13,363.20	\$1.10	\$16,896.00	\$0.92	\$14,080.00
E	Seal Coat Parking Lot	16,300	SY	\$1.12	\$18,256.00	\$0.68	\$11,084.00	\$0.82	\$13,366.00	\$1.05	\$17,115.00	\$0.85	\$13,855.00
F	Parking Lot Paint Pavement Marking - Line 4"	9,340	FT	\$0.75	\$7,005.00	\$0.22	\$2,054.80	\$0.21	\$1,961.40	\$0.25	\$2,335.00	\$0.23	\$2,117.07
G	Parking Lot Paint Pavement Marking - Letters & Symbols	287	SF	\$3.50	\$1,004.50	\$3.00	\$861.00	\$1.95	\$559.65	\$4.50	\$1,281.50	\$3.15	\$904.05
H	Traffic Control and Protection - DuPage County	1	LSUM	\$1,000.00	\$1,000.00	\$1,000.00	\$1,000.00	\$500.00	\$500.00	\$7,000.00	\$7,000.00	\$2,833.33	\$2,833.33
TOTAL					\$1,086,045.45		\$831,167.48		\$869,872.50		\$965,998.75		
BID					\$1,086,045.45		\$831,167.48		\$869,872.50		\$965,998.75		\$869,012.91

CITY OF DARIEN

PROJECT FILE NAME: CRACK SEALING AND SEAL COATING SERVICES
 PROJECT NO.: 2016-02

DATE: 3/31/2016
 TIME: 10:00 A.M.
 TABULATED BY: BWT

NO	ITEM	QUAN	UNIT	ENGINEER'S ESTIMATE		Denler, Inc. 19148 S. 104th Avenue Mokana, IL 60448		SKC Construction, Inc. PO Box 503 West Dundee, IL 60118		Behm Pavement Maintenance 3010 Route 176 Crystal Lake, IL 60014		Average Unit Price	
				UNIT PRICE	TOTAL	UNIT PRICE	TOTAL	UNIT PRICE	TOTAL	UNIT PRICE	TOTAL	UNIT PRICE	TOTAL
A	Crack Sealing Asphalt Pavement	105,000	LB	\$1.54	\$161,700.00	\$1.195	\$125,475.00	\$1.256	\$131,880.00	\$1.37	\$143,850.00	\$1.27	\$133,735.00
B	Crack and Joint Sealing PCC Pavement	0	LB	\$2.47	\$0.00	\$3.85	\$0.00	\$1.47	\$0.00	\$2.50	\$0.00	\$2.61	\$0.00
C	Fiber-Asphalt Crack Sealing Asphalt Pavement	0	LB	\$1.72	\$0.00	\$1.265	\$0.00	\$1.31	\$0.00	\$1.47	\$0.00	\$1.35	\$0.00
D	Seal Coat Bike Path	0	SY	\$1.12	\$0.00	\$0.78	\$0.00	\$0.87	\$0.00	\$1.10	\$0.00	\$0.92	\$0.00
E	Seal Coat Parking Lot	0	SY	\$1.12	\$0.00	\$0.68	\$0.00	\$0.82	\$0.00	\$1.05	\$0.00	\$0.85	\$0.00
F	Parking Lot Paint Pavement Marking - Line 4"	2,200	FT	\$0.75	\$1,650.00	\$0.22	\$484.00	\$0.21	\$462.00	\$0.25	\$550.00	\$0.23	\$498.67
G	Parking Lot Paint Pavement Marking - Letters & Symbols	225	SF	\$3.50	\$787.50	\$3.00	\$675.00	\$1.95	\$438.75	\$4.50	\$1,012.50	\$3.15	\$708.75
H	Traffic Control and Protection - DuPage County	0	LSUM	\$1,000.00	\$0.00	\$1,000.00	\$0.00	\$500.00	\$0.00	\$7,000.00	\$0.00	\$2,833.33	\$0.00
TOTAL													
BID					\$164,137.50		\$126,634.00		\$132,780.75		\$145,412.50		\$134,942.42

CITY OF DARIEN 2016 PROGRAM - CRACK SEALING WITH AWARDED VENDOR

NO	ITEM	QUAN	UNIT	UNIT PRICE	TOTAL	UNIT PRICE	TOTAL	UNIT PRICE	TOTAL	UNIT PRICE	TOTAL	UNIT PRICE	TOTAL
A	Crack Sealing Asphalt Pavement	153,766	LB	\$1.54	\$236,798.10	\$1.195	\$183,749.15	\$1.256	\$193,128.84	\$1.37	\$210,658.05	\$1.27	\$195,245.36

ROAD	SUB-DIVISION	LIMITS	ROAD LENGTH	LAST REHAB	ESTIMATED POUNDS
Roger Road	Marion Hills North	Plainfield to CHR	1120	2013	2500
Eleanor Place	Marion Hills North	69th to Holly	1050	2013	3000
Poplar Lane	Marion Hills South	Elm to Janet	840	2012	800
High Rd	Marion Hills North/South	67th to Janet	3500	2012	8500
74th Place	Marion Hills South	83rd to Eleanor	1000	2009	1800
Brookbank	Marion Hills South	Elm to Janet	600	2010	500
Eleanor Place	Marion Hills South	Elm to Janet	980	2010	800
Western	Clarefield	67th to Chestnut	1093	2010	3200
Leonard	Clarefield	67th to Chestnut	1093	2010	3200
Trenton Lane	Farmingdale Heights	67th to Albany	530	2009	2500
Albany Lane	Farmingdale Heights	Trenton to Richmond	350	2009	2000
Columbia Lane	Farmingdale Heights	Richmond to Charleston	660	2010	1800
Charleston Drive	Farmingdale Heights	Chestnut to 67th	1210	2007	2500
Village Court	Hinsbrook	Seminole to limit	500	2010	500
Tennessee	North of 67th	67th to limit	760	2007	1000
Easy	North of 67th	Tennessee to limit	222	2007	800
Maple Ln	Hinsbrook	Clarendon Hills to Richmond	3500	2012	10000
Seminole CDS	Hinsbrook	Seminole to limit	240	2009	1000
Tamarack	Hinsbrook	Richmond to beechnut	2200	2012	3000
Belair Dr	Hinsbrook	Richmond to beechnut	2200	2009	8500
Belair CDS	Hinsbrook	Belair to limit	160	2009	600
Bentley	Plainfield Highlands	71st to 73rd	1000	2012	1200
Leonard	Plainfield Highlands	Plainfield rd to 72nd	1660	2009	2500
Ripple Ridge	Hidden lakes	Hinswood to Limit	2750	2010	3200
Mystic Trace	Hidden lakes	Ripple Ridge to S frontage	970	2010	2300
Hinswood Dr	Hidden Lakes	Cass to Limit	1120	2009	6000
Dorchester Ln	Farmingdale terrace N	79th to Somerset	615	2013	800
Somerset Ln	Farmingdale terrace N	Dorchester to mayfair	335	2013	600
Mayfair Ln	Farmingdale terrace N	79th to Somerset	615	2013	500
Nantucket Drive	Farmingdale terrace N	79th to 75th	2600	2010	8000
Comstock Ln	Farmingdale terrace W	Nantucket to Walnut	900	2010	2500
Regency Grove	Regency Grove	Cass to Limit	2000	2009	8000
Wildwood	Regency Grove	Regency grove to limit	400	2007	600
Adams	Regency Grove	Plainfield to limit	840	2009	1000
Stratford Place	Brookhaven #1	Walnut to 79th	1800	2010	3000
Linden ave	Brookhaven #1	Plainfield to 79th	1420	2007	600
Country Lane	Brookhaven #2	Plainfield to limit	1200	2007	2500
Exner Ct	Farmingdale Terrace 5-9	Exner to Limit	200	2012	1000
Bantry Ct	Darien Club	Darien club to limit	200	2012	800
Clover Ct	Darien Club	Darien club to limit	350	2012	600
Irish Ct	Darien Club	Darien club to limit	350	2012	800
Allison Ln	Darien Club	Cass to Limit	400	2010	800
Williams	Farmingdale 5-9	Holly to Claremont	280	2010	800
Howdy Ln	Downers Farview	Gold Grove to Wirth	540	2013	600

77th	brookhaven #2	Williams to Adams	1500	2010	3000
Redondo Ct	Knottingham	Knottingham to limit	400	2013	1200
Thistlewood Ln	Carriage Greens 3	Evergreen to Limit	1125	2010	3000
Emerson Dr	Farmingdale 5,6,7,8,9	73rd to 71st	1460	2009	3000
Whittier Dr	Farmingdale 5,6,7,8,9	73rd to Whittier	660	2009	2500
Harper Rd	Farm Ridge	Wilton to Exton	450	2009	1200
Exton St	Farm Ridge	Harper to Judd	550	2009	2000
Judd St	Farm Ridge	Fairveiw to Wilton	475	2009	1000
Wilton Rd	Farm Ridge	Exton to Limit	1050	2009	3200
Main	Farm Ridge	75th to Limit	1020	2009	2000
Lyman	Farmingdale Ridge	75th to Manning	1350	2010	4000
Water Plant 3			300	2010	500
Beller Dr	Farmingdale Village	Lemont to 83rd	4870	2010	15000
Ailsworth Dr	Farmingdale Village	Beller to Limit	1420	2010	5000
Ailsworth Ct	Farmingdale Village	Ailsworth to Limit	535	2010	1000
Pitcher Dr	Farmingdale Village	Ailsworth to Clifford	860	2008	3000
Clifford Rd	Farmingdale Village	Pitcher to Stewart	660	2008	2500
Stewart Rd	Farmingdale Village	Clifford to Ailsworth	860	2008	3000
Woodvale Dr	Farmingdale Village	87th to Beller	1270	2013	1200
Beller Ct	Farmingdale Village	Beller to Limit	485	2013	500
Highcrest Dr	Farmingdale Village	Beller to Hilside	765	2013	1000
Ashley Ct	Knottingham Cir	Knottingham to Limit	300	2010	600
Durham Cir	Knottingham Cir	Knottingham to Limit	300	2010	600
Lakeview Dr	Bailey park	Bailey to Plainfield	3800	2010	6000
Adams St	Farmingdale South	Greenbriar to Iroquois	1000	2010	2400
			73818.00		175600.00

Miles 14.0

Pounds 150,000- 175,000

RESOLUTION NO. _____

A RESOLUTION AUTHORIZING THE MAYOR AND CITY CLERK TO EXECUTE A CONTRACT WITH DENLER, INC. IN AN AMOUNT NOT TO EXCEED \$183,750 FOR THE 2016 CRACK FILL PROGRAM

BE IT RESOLVED BY THE CITY COUNCIL OF THE CITY OF DARIEN, DU PAGE COUNTY, ILLINOIS, as follows:

SECTION 1: The City Council of the City of Darien hereby authorizes the Mayor and City Clerk to execute a contract with Denler, Inc. in an amount not to exceed \$183,750 for the 2016 Crack Fill Program, a copy of which is attached hereto as "**Exhibit A**".

SECTION 2: This Resolution shall be in full force and effect from and after its passage and approval as provided by law.

PASSED BY THE CITY COUNCIL OF THE CITY OF DARIEN, DU PAGE COUNTY, ILLINOIS, this 2nd day of May, 2016.

AYES: _____

NAYS: _____

ABSENT: _____

APPROVED BY THE MAYOR OF THE CITY OF DARIEN, DU PAGE COUNTY, ILLINOIS, this 2nd day of May, 2016.

KATHLEEN MOESLE WEAVER, MAYOR

ATTEST:

JOANNE E. RAGONA, CITY CLERK

APPROVED AS TO FORM

CITY ATTORNEY

SUBMISSION INFORMATION

Village of Woodridge Public Works Department
One Plaza Drive
Woodridge, IL 60517

INVITATION # 2016-02
BID OPENING DATE: March 31, 2016
TIME: 10:00 A.M. Local Time
LOCATION: Village Hall

COPIES: One (1) original & ten (10) copies

INVITATION TO BID CONTRACTOR INFORMATION

Company Name: Dealer, Inc.
Address: 19147 S. 103rd Ave.
City, State, Zip Code: Alsop, IL 60448

Crack Sealing and Seal Coating Services
per the specifications identified herein

I. BASE BID ITEMS

A. CRACK SEALING ASPHALT PAVEMENT

Item	Est. Qty.	Unit	UNIT PRICE	ANNUAL COST
1 Crack Sealing Asphalt Pavement per the specifications identified herein- Year 1	569,375	LB	\$ <u>1.195</u>	\$ <u>681,000.63</u>
2 Year 2 (optional)	563,375	LB	\$ <u>1.29</u>	\$ <u>726,753.75</u>
3 Year 3 (optional)	558,031	LB	\$ <u>1.32</u>	\$ <u>736,600.92</u>

B. CRACK AND JOINT SEALING PCC PAVEMENT

Item	Est. Qty.	Unit	UNIT PRICE	ANNUAL COST
1 Crack and Joint Sealing PCC Pavement per the specifications identified herein- Year 1	1,275	LB	\$ <u>3.85</u>	\$ <u>4,908.75</u>
2 Year 2 (optional)	1,275	LB	\$ <u>3.85</u>	\$ <u>4,908.75</u>
3 Year 3 (optional)	1,275	LB	\$ <u>3.85</u>	\$ <u>4,908.75</u>

C. FIBER-ASPHALT CRACK SEALING ASPHALT PAVEMENT

Item	Est. Qty.	Unit	UNIT PRICE	ANNUAL COST
1 Fiber-Asphalt Crack Sealing Asphalt Pavement per the specifications Identified herein- Year 1	93,500	LB	\$ <u>1.265</u>	\$ <u>118,277.50</u>
2 Year 2 (optional)	67,500	LB	\$ <u>1.36</u>	\$ <u>91,800.-</u>
3 Year 3 (optional)	67,600	LB	\$ <u>1.395</u>	\$ <u>94,162.50</u>

D. SEAL COAT BIKE PATH

Item	Est. Qty.	Unit	UNIT PRICE	ANNUAL COST
1 Seal Coat Bike Path per the specifications Identified herein- Year 1	15,350	SY	\$ <u>.78</u>	\$ <u>11,950.80</u>
2 Year 2 (optional)	11,280	SY	\$ <u>.80</u>	\$ <u>9,024.-</u>
3 Year 3 (optional)	7,325	SY	\$ <u>.82</u>	\$ <u>6,006.50</u>

E. SEAL COAT PARKING LOT

Item	Est. Qty.	Unit	UNIT PRICE	ANNUAL COST
1 Seal Coat Parking Lot per the specifications Identified herein- Year 1	16,300	SY	\$ <u>.68</u>	\$ <u>11,084.-</u>
2 Year 2 (optional)	12,936	SY	\$ <u>.70</u>	\$ <u>9,055.20</u>
3 Year 3 (optional)	13,860	SY	\$ <u>.72</u>	\$ <u>9,835.20</u>

F. PARKING LOT PAINT PAVEMENT MARKING -- LINE 4"

Item	Est. Qty.	Unit	UNIT PRICE	ANNUAL COST
1 Parking Lot Paint Pavement Marking - Line 4" per the specifications Identified herein- Year 1	9,340	FT	\$ <u>.22</u>	\$ <u>2,054.80</u>
2 Year 2 (optional)	10,135	FT	\$ <u>.23</u>	\$ <u>2,331.05</u>
3 Year 3 (optional)	7,565	FT	\$ <u>.24</u>	\$ <u>1,815.60</u>

G. PARKING LOT PAINT PAVEMENT MARKING -- LETTERS & SYMBOLS

	Item	Est. Qty	Unit	UNIT PRICE	ANNUAL COST
1	Parking Lot Paint Pavement Marking – Letters & Symbols per the specifications identified herein- Year 1	287	SF	\$ <u>3.00</u>	\$ <u>861.-</u>
2	Year 2 (optional)	280	SF	\$ <u>3.35</u>	\$ <u>938.-</u>
3	Year 3 (optional)	295	SF	\$ <u>3.50</u>	\$ <u>1032.50</u>

H. TRAFFIC CONTROL AND PROTECTION- DUPAGE COUNTY

	Item	Est. Qty.	Unit	UNIT PRICE	ANNUAL COST
1	Traffic Control and Protection – DuPage County- Year 1	1	LSUM	\$ <u>1000</u>	\$ <u>1000.-</u>
2	Year 2 (optional)	1	LSUM	\$ <u>1000</u>	\$ <u>1000.-</u>
3	Year 3 (optional)	1	LSUM	\$ <u>1000</u>	\$ <u>1000.-</u>

BASE BID – YEAR 1 TOTALS

\$ 831,167.48

I. ANNUAL DISCOUNT IF CONTRACTOR IS ALLOWED TO STORE EQUIPMENT AT LOCAL PUBLIC AGENCY FACILITY

LPA	Will LPA allow storage of equipment overnight at their facility?	Will Contractor utilize space at LPA's facility to store equipment overnight? (Please check)		Annual Discount
Village of Burr Ridge	Yes	Yes <input type="checkbox"/>	No <input checked="" type="checkbox"/>	_____ %
City of Darien	Yes	Yes <input checked="" type="checkbox"/>	No <input type="checkbox"/>	<u>.5</u> %
Village of Downers Grove	Yes	Yes <input checked="" type="checkbox"/>	No <input type="checkbox"/>	<u>.5</u> %
DuPage County	No	<input type="checkbox"/>	<input type="checkbox"/>	<u>n/a</u> %
Village of Lombard	Yes	Yes <input checked="" type="checkbox"/>	No <input type="checkbox"/>	<u>.5</u> %
Village of Villa Park	No	<input type="checkbox"/>	<input type="checkbox"/>	<u>n/a</u> %
City of West Chicago	No	<input type="checkbox"/>	<input type="checkbox"/>	<u>n/a</u> %
City of Wheaton	Yes	Yes <input checked="" type="checkbox"/>	No <input type="checkbox"/>	<u>.5</u> %
Village of Woodridge	No	<input type="checkbox"/>	<input type="checkbox"/>	<u>n/a</u> %

BIDS SHALL BE ACCOMPANIED BY BID SECURITY IN AN AMOUNT NOT LESS THAN FIVE PERCENT (5%) OF THE AMOUNT OF THE TOTAL BID.

All work under this contract shall comply with the Prevailing Wage Act of the State of Illinois, 820 ILCS 130/0.01 et seq. & the Employment of Illinois Workers on Public Works Act (30 ILCS 570/0.01).

THE SECTION BELOW MUST BE COMPLETED IN FULL AND SIGNED

The undersigned hereby certifies that they have read and understand the contents of this solicitation and agree to furnish at the prices shown any or all of the items above, subject to all instructions, conditions, specifications and attachments hereto. Failure to have read all the provisions of this solicitation shall not be cause to alter any resulting contract or to accept any request for additional compensation. By signing this bid document, the bidder hereby certifies that they are not barred from bidding on this contract as a result of a violation of either Section 33E-3 or 33E-4 of the Illinois Criminal Code of 1961, as amended.

Authorized Signature: *David J. Dentler* Company Name: *Dentler, Inc.*
Typed/Printed Name: *David J. Dentler* Date: *3/25/16*
Title: *President* Telephone Number: *708 472 5025*
E-mail: *ddentler@dentlerinc.com*

LABOR STATUTES, RECORDS AND RATES

CONSTRUCTION CONTRACTS

for

LOCAL PUBLIC AGENCIES - STATE OF ILLINOIS

MARCH 2016

All Contractors shall familiarize themselves with all provisions of all Acts referred to herein and in addition shall make an investigation of labor conditions and all negotiated labor agreements which may exist or are contemplated at this time. Nothing in the Acts referred to herein shall be construed to prohibit the payment of more than the prevailing wage scale.

In the employment and use of labor, the Contractor and any subcontractor of the Contractor shall conform to all Illinois Constitutional and statutory requirements including, but not limited to, the following:

- 1.0 Equal Employment Opportunity:
 - 1.1 Illinois Constitution, Article I, Section 17, which provides: "All persons shall have the right to be free from discrimination on the basis of race, color, creed, national ancestry and sex in the hiring and promotion practices of any employer or in the sale or rental of property."
 - 1.2 Illinois Constitution, Article I, Section 18, which provides: "The equal protection of the laws shall not be denied or abridged on account of sex by the state of its units of local government and school districts."
 - 1.3 The Public Works Employment Discrimination Act, 775 ILCS 10/1, provides in substance that no person may be refused or denied employment by reason of unlawful discrimination, nor may any person be subjected to unlawful discrimination in any manner in connection with contracting for or performance of any work or service of "any kind by, for, on behalf of, or for the benefit of the State, or of any department, bureau, commission, board or other political subdivision or agency thereof."
 - 1.4 Contractor shall comply with the Illinois Human Rights Act, 775 ILCS 5/1-101 et seq., as amended and any rules and regulations promulgated in accordance therewith, including, but not limited to the Equal Employment Opportunity Clause, Illinois Administrative Code, Title 44, Part 750 (Appendix A), which is incorporated herein by reference. Furthermore, the Contractor shall comply with the Public Works Employment Discrimination Act, 775 ILCS 10/0.01 et seq., as amended.
- 2.0 The Veterans Preference Act, 330 ILCS 55/1, provides: "In the employment and appointment to fill positions in the construction, addition to, or alteration of all public works undertaken or contracted for by the State, or any of its political subdivisions thereof, preference shall be given to persons who have been members of the Armed Forces of the United States...in times of hostilities with a foreign country .."
- 3.0 The Servicemen's Employment Tenure Act, as amended, 330 ILCS 60/2, "safeguarding the employment and the rights and privileges inhering in the employment contract, of servicemen."
- 4.0 The Prevailing Wage Act, 820 ILCS 130/0.01 et seq., provides: "It is the policy of the State of Illinois that a wage of no less than the general prevailing hourly rate as paid for work of a similar character in the locality in which the work is performed, shall be paid to all laborers, workers and mechanics employed by or on behalf of any and all public bodies engaged in public works." The current Schedule of Prevailing Wages for DuPage County must be prominently posted at the project site by the Contractor.
 - 4.1 The Prevailing Wage Act, 820 ILCS 130/4, provides: "All bid specifications shall list the specified rates to all laborers, workers and mechanics in the locality for each craft or type of worker or mechanic needed to execute the contract. If the Department of Labor revises the prevailing rate of hourly wages to be paid by the public body, the revised rate shall apply to such contract, and the public body shall be responsible to notify the Contractor and each subcontractor of the revised rate."
 - 4.1.1 The LPA shall notify the Contractor of any revised rates as determined by the Department of Labor and as received by the LPA. It shall be the responsibility and liability of the Contractor to promptly notify each and every subcontractor of said revised rates.

- 4.1.2 Unless otherwise specified in the Contract Documents, the Contractor shall assume all risks and responsibility for any changes to the prevailing hourly wage which may occur during the Contract Time. A revision to the prevailing rate of hourly wages shall not be cause for any adjustment in the Contract Sum.
- 4.2 The Prevailing Wage Act, 820 ILCS 130/5 provides that the Contractor and each Sub Contractor shall, "submit monthly, in person, by mail or electronically a certified payroll to the public body in charge of the project."
- 4.2.1 The Contractor shall submit to the LPA by the fifteenth day, monthly, a certified payroll list including all workers, laborers and mechanics employed by the Contractor and each of the Sub Contractors.
- 4.2.2 The certified payroll records shall include each worker's name, address, telephone number, social security number, classification, number of hours worked each day, the hourly wage and starting and ending times each day.
- 4.2.3 Included with the payroll records, the Contractor and each Sub Contractor shall attest, in writing, to the veracity and accuracy of the records and that the hourly rate paid is not less than the general prevailing wages required.
- 5.0 The Child Labor Law, as amended, 820 ILCS 205/1, which provides: "No minor under 16 years of age...at any time shall be employed, permitted or suffered to work in any gainful occupation...in any type of construction work within this state."
- 6.0 **DRUG FREE WORK PLACE**
- 6.1 Contractor, as a party to a public contract, certifies and agrees that it will provide a drug free workplace by:
- 6.1.1 Publishing a statement:
- (1) Notifying employees that the unlawful manufacture, distribution, dispensation, possession or use of a controlled substance, including cannabis, is prohibited in the Village's or Contractor's workplace.
 - (2) Specifying the actions that will be taken against employees for violations of such prohibition.
 - (3) Notifying the employee that, as a condition of employment on such contract or grant, the employee will:
 - (A) abide by the terms of the statement; and
 - (B) notify the employer of any criminal drug statute conviction for a violation occurring in the workplace no later than five (5) days after such conviction.
- 6.1.2 Establishing a drug free awareness program to inform employees about:
- (1) the dangers of drug abuse in the workplace;
 - (2) the Village's or Contractor's policy of maintaining a drug free workplace;
 - (3) any available drug counseling, rehabilitation and employee assistance programs;
 - (4) the penalties that may be imposed upon employees for drug violations.
- 6.1.3 Providing a copy of the statement required by subparagraph 1.1 to each employee engaged in the performance of the contract or grant and to post the statement in a prominent place in the workplace.
- 6.1.4 Notifying the contracting or granting agency within ten (10) days after receiving notice under part (3)(B) of subparagraph 1.1 above from an employee or otherwise receiving actual notice of such conviction.
- 6.1.5 Imposing a sanction on, or requiring the satisfactory participation in a drug abuse assistance or rehabilitation program by, any employee who is so convicted as required by section 5 of the Drug Free Workplace Act.
- 6.1.6 Assisting employees in selecting a course of action in the event drug counseling, treatment and rehabilitation is required and indicating that a trained referral team is in place.
- 6.1.7 Making a good faith effort to continue to maintain a drug free workplace through implementation of the Drug Free Workplace Act.

7.0 SUBSTANCE ABUSE PREVENTION ON PUBLIC WORKS PROJECTS ACT

7.1 In the event this is a public works project as defined under the Prevailing Wage Act, 820 ILCS 130/2, Contractor agrees to comply with the Substance Abuse Prevention on Public Works Projects Act , 820 ILCS 285/1 et seq., and further agrees that all of its subcontractors shall comply with such Act..

As required by the Act, Contractor agrees that it will file with the Village prior to commencing work its written substance abuse prevention program and/or that of its subcontractor(s) which meet or exceed the requirements of the Act.

8.0 PATRIOT ACT COMPLIANCE

8.1 The Contractor represents and warrants to the Village that neither it nor any of its principals, shareholders, members, partners, or affiliates, as applicable, is a person or entity named as a Specially Designated National and Blocked Person (as defined in Presidential Executive Order 13224) and that it is not acting, directly or indirectly, for or on behalf of a Specially Designated National and Blocked Person. The Contractor further represents and warrants to the Village that the it and its principals, shareholders, members, partners, or affiliates, as applicable are not, directly or indirectly, engaged in, and are not facilitating, the transactions contemplated by this Contract on behalf of any person or entity named as a Specially Designated National and Blocked Person. The Contractor hereby agrees to defend, indemnify and hold harmless the Village, and its elected or appointed officers, employees, agents, representatives, engineers and attorneys, from and against any and all claims, damages, losses, risks, liabilities and expenses(including reasonable attorney's fees and costs) arising from or related to any breach of the foregoing representations and warranties.

The Contractor will include verbatim or by reference the provisions contained herein in every subcontract it awards under which any portion of the contract obligations are undertaken or assumed, so that such provisions will be binding upon such subcontractor. The Contractor will be liable for compliance with these provisions by such subcontractors.

The Contractor and each subcontractor shall keep or cause to be kept an accurate record of names, occupations and actual wages paid to each laborer, workman and mechanic employed by him in connection with the contract. This record shall be open at all reasonable hours for inspection by any representative of the LPA or the Illinois Department of Labor and must be preserved for five (5) years following completion of the contract.

The current Prevailing Wages Rates for DuPage County can be found at:

<http://www.state.il.us/agency/idol/rates/rates.HTM>

CONTRACTOR REFERENCES

Please list below five (5) references for which your firm has performed similar work for LPAs as identified in Bidder Qualifications.

Agency: Village of Lombard
 Address: 1051 S. Hammerichmidt
 City, State, Zip Code: Lombard, IL
 Contact Person/
 Telephone Number: 630 620 5740 Tom Birro
 Dates of Service/Award
 Amount: 2015 - \$125,000.-

Agency: Village of Villa Park
 Address: 20 S. Ardmore Ave.
 City, State, Zip Code: Villa Park, IL 60181
 Contact Person/Telephone
 Number: Kevin Mantels
630-834-8525
 Dates of Service/Award
 Amount: 2015 - \$130,000.-

Agency: Village of Woodridge
 Address: 1 Pison Dr.
 City, State, Zip Code: Woodridge, IL 60517
 Contact Person/
 Telephone Number: Orlando Tompall
630-719-2941
 Dates of Service/Award
 Amount: 2015 - \$125,000.-

Agency: City of Naperville
 Address: 400 S. Eagle St.
 City, State, Zip Code: Naperville, IL 60566
 Contact Person/
 Telephone Number: Peter Zibole
630-420-4131
 Dates of Service/Award
 Amount: 2015 - \$100,000.-

Agency: Will County DOT
 Address: 16841 W. Laramay Rd.
 City, State, Zip Code: Joliet, IL 60477
 Contact Person/
 Telephone Number: Bruce Gould
815 727 8476
 Dates of Service/Award
 Amount: 2015 - \$1500,000.-

DISQUALIFICATION OF CERTAIN BIDDERS

(3)

PERSONS AND ENTITIES SUBJECT TO DISQUALIFICATION

No person or business entity shall be awarded a contract or subcontract, for a stated period of time, from the date of conviction or entry of a plea or admission of guilt, if the person or business entity,

- (A) has been convicted of an act committed, within the State of Illinois or any state within the United States, of bribery or attempting to bribe an officer or employee in the State of Illinois, or any State in the United States in that officer's or employee's official capacity;
- (B) has been convicted of an act committed, within the State of Illinois or any state within the United States, of bid rigging or attempting to rig bids as defined in the Sherman Anti-Trust Act and Clayton Act 15 U.S.C. Sec. 1 et seq.;
- (C) has been convicted of bid rigging or attempting to rig bids under the laws of the State of Illinois, or any state in the United States;
- (D) has been convicted of bid rotating or attempting to rotate bids under the laws of the State of Illinois, or any state in the United States;
- (E) has been convicted of an act committed, within the State of Illinois or any state in the United States, of price-fixing or attempting to fix prices as defined by the Sherman Anti-Trust Act and Clayton Act 15 U.S.C. Sec. 1 et seq.;
- (F) has been convicted of price-fixing or attempting to fix prices under the laws of the State of Illinois, or any state in the United States;
- (G) has been convicted of defrauding or attempting to defraud any unit of state or local government or school district within the State of Illinois or in any state in the United States;
- (H) has made an admission of guilt of such conduct as set forth in subsection (A) through (F) above which admission is a matter of record, whether or not such person or business entity was subject to prosecution for the offense or offenses admitted to;
- (I) has entered a plea of nolo contendere to charges of bribery, price fixing, bid rigging, bid rotating, or fraud; as set forth in subparagraphs (A) through (F) above.

Business entity, as used herein, means a corporation, partnership, limited liability company trust, association, unincorporated business or individually owned business.

By signing this document, the bidder hereby certifies that they are not barred from bidding on this contract as a result of a violation of either Section 33E-3 or 33E-4 of the Illinois Criminal Code of 1961, as amended.

Ang M. ... President

(Signature of Bidder if the Bidder is an Individual)
(Signature of Partner if the Bidder is a Partnership)
(Signature of Officer if the Bidder is a Corporation)

The above statements must be subscribed and sworn to before a notary public.

Subscribed and Sworn to this 25 day of March 2016

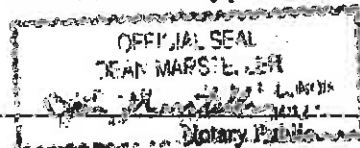

Failure to complete and return this form may be considered sufficient reason for rejection of the bid.

ANTI-COLLUSION AFFIDAVIT AND CONTRACTOR'S CERTIFICATION

David J. Bender being first duly sworn,

deposes and says that he is President
(Partner, Officer, Owner, Etc.)

of Deerfoot, Inc.
(Contractor)

the party making the foregoing proposal or bid, and that such bid is genuine and not collusive, or sham; that said bidder has not colluded, conspired, connived or agreed, directly or indirectly, with any bidder or person, to put in a sham bid or to refrain from bidding, and has not in any manner, directly or indirectly, sought by agreement or collusion, or communication or conference with any person; to fix the bid price element of said bid, or of that of any other bidder, or to secure any advantage against any other bidder or any person interested in the proposed contract.

The undersigned certifies that he is not barred from bidding on this contract as a result of a conviction for the violation of State laws prohibiting bid-rigging or bid-rotating.

David J. Bender President

(Signature of Bidder if the Bidder is an Individual)
(Signature of Partner if the Bidder is a Partnership)
(Signature of Officer if the Bidder is a Corporation)

The above statements must be subscribed and sworn to before a notary public.
Subscribed and Sworn to this 25 day of March, 2016



Notary Public

Failure to complete and return this form may be considered sufficient reason for rejection of the bid.

CONFLICT OF INTEREST

David T. Sawyer

, hereby certifies that

It has conducted an investigation into whether an actual or potential conflict of interest exists between the bidder, its owners and employees and any official or employee of a Local Public Agency identified herein.

Bidder further certifies that it has disclosed any such actual or potential conflict of interest and acknowledges if bidder has not disclosed any actual or potential conflict of interest, the Village of Woodridge may disqualify the bid or the affected Local Public Agency may void any award and acceptance that the Local Public Agency has made.

Am. Mh., President

(Signature of Bidder if the Bidder is an Individual)
(Signature of Partner if the Bidder is a Partnership)
(Signature of Officer if the Bidder is a Corporation)

The above statements must be subscribed and sworn to before a notary public.

Subscribed and Sworn to this 25 day of March, 2016

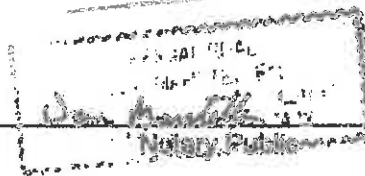

Failure to complete and return this form may be considered sufficient reason for rejection of the bid.

TAX COMPLIANCE AFFIDAVIT

David J. Decker, being first duly sworn, deposes and says that (s)he is
President of Decker, Inc.
(Partner, Officer, Owner, Etc.) (Contractor)

the individual or entity making the foregoing proposal or bid, and certifies that (s)he is not barred from contracting with the any of the Local Public Agencies identified herein because of any delinquency in the payment of any tax administered by the Department of Revenue unless the individual or entity is contesting, in accordance with the procedures established by the appropriate revenue act. The individual or entity making the proposal or bid understands that making a false statement regarding delinquency in taxes is a Class A Misdemeanor and, in addition, voids the contract and allows the Local Public Agency to recover all amounts paid to the individual or entity under the contract in civil action.

David J. Decker, President
(Signature of Bidder if the Bidder is an Individual)
(Signature of Partner if the Bidder is a Partnership)
(Signature of Officer if the Bidder is a Corporation)

The above statements must be subscribed and sworn to before a notary public.

Subscribed and Sworn to this 25 day of March, 2016

David J. Decker
Notary Public
Notary Seal

Failure to complete and return this form may be considered sufficient reason for rejection of the bid.

PARTICIPATION AFFIDAVIT

David J. Decker, being first duly sworn, deposes and says, under penalties as provided in Section 1-109 of the Illinois Code of Civil Procedure, 735 ILCS 5/1-109, that (s)he is

President of Decker, Inc.
(Partner, Officer, Owner, Etc.) (Contractor)

the individual or entity making the foregoing proposal or bid, and certifies that the Contractor or Subcontractor, respectively, is not barred from being awarded a contract or subcontract pursuant to 30 ILCS 500/50-10. Additionally, the Contractor or Subcontractor, respectively, certifies he/she is not suspended from doing business with any State, Federal or Local Agency.

David J. Decker, President
(Signature of Bidder if the Bidder is an Individual)
(Signature of Partner if the Bidder is a Partnership)
(Signature of Officer if the Bidder is a Corporation)

The above statements must be subscribed and sworn to before a notary public.

Subscribed and Sworn to this 25 day of March, 2016

David J. Decker
Notary Public

Failure to complete and return this form will be considered sufficient reason for rejection of the bid.

RETURN WITH BID



Required Vendor Ethics Disclosure Statement

Company Name:	Decker, Inc.		
Company Contact:	David J. Decker	Contact Phone:	708 479 5225
Bid/Contract/PO:	Crack Sealing and Seal Coating Services	Contact Email:	ddecker@deckerinc.com

The DuPage County Procurement Ordinance requires the following written disclosures prior to award:

1. Every contractor, union, or vendor that is seeking or has previously obtained a contract, change orders to one (1) or more contracts, or two (2) or more individual contracts with the county resulting in an aggregate amount at or in excess \$25,000, shall provide to Procurement Services Division a written disclosure of all political campaign contributions made by such contractor, union, or vendor within the current and previous calendar year to any incumbent county board member, county board chairman, or countywide elected official whose office the contract to be awarded will benefit. The contractor, union or vendor shall update such disclosure annually during the term of a multi-year contract and prior to any change order or renewal requiring approval by the county board. For purposes of this disclosure requirement, "contractor or vendor" includes owners, officers, managers, lobbyists, agents, consultants, bond counsel and underwriters counsel, subcontractors and corporate entities under the control of the contracting person, and political action committees to which the contracting person has made contributions.

I have made the following campaign contributions within the current and previous calendar year:
 If no contributions have been made enter "NONE" below:

Recipient	Donor	Description (e.g., cash, type of item, in-kind service, etc.)	Amount/Value	Date Made
NONE				

Attach additional sheets if necessary. Sign each added sheet and number each page (#) of (total pages).

2. All contractors and vendors who have obtained or are seeking contracts with the county shall disclose the names and contact information of their lobbyists, agents and representatives and all individuals who are or will be having contact with county officers or employees in relation to the contract or bid and shall update such disclosure with any changes that may occur.

Lobbyists, Agents And Representatives And All Individuals Who Are Or Will Be Having Contact With County Officers Or Employees In Relation To The Contract Or Bid	Telephone	Email
NONE		

A contractor or vendor that knowingly violates these disclosure requirements is subject to penalties which may include, but are not limited to, the immediate cancellation of the contract and possible disbarment from future county contracts.

Continuing disclosure is required, and I agree to update this disclosure form as follows:

- If information changes, within five (5) days of change, or prior to county action, whichever is sooner
- 30 days prior to the optional renewal of any contract
- Annual disclosure for multi-year contracts on the anniversary of said contract
- With any request for change order except those issued by the county for administrative adjustments.

The full text of the county's ethics and procurement policies and ordinances are available at <http://www.dupageco.org/CountyBoard/Policies/>

I hereby acknowledge that I have received, have read, and understand these requirements.

Authorized Signature David J. Decker

Printed Name David J. Decker

Title President

Date 3/25/16

Page 1 of 1 Failure to complete and return this form may result in delay or cancellation of the County's Contractual Obligation.



Required Vendor Ethics Disclosure Statement (continued)

Recipient	Donor	Description (ag., cash, type of firm, in-kind service, etc.)	Amount/Value	Date Made
None				

Ang, M
Signature

3/25/16
Date

instructions

Vendor Ethics Disclosure Statement

This form is filed by contract; a separate disclosure form must be filed for every contract action or informational update.

Company Name: Name under which the contract is or will be awarded.

Company Contact & Phone: Individual to be contacted if necessary

"Bid/Contract/PO/Description" identifying County reference. If an identifying County number has not been issued, include a detailed description of the services or goods to be provided including dollar amount, time frame, etc.

Section: B Contribution

Recipient: identify recipient of contribution

Donor: name under which the contribution was made, identify relationship to contractor

Description: identify the nature of the contribution

Amount/Value: monetary value of the contribution and method of valuation **Date**

Made: date of contribution

Authorization:

Signature, Name and Title of individual/officer/agent legally authorized to sign on behalf of the contractor.

Date: date form was completed and signed.

CAMPAIGN DISCLOSURE CERTIFICATE

Any contractor, proposer, bidder or vendor who responds by submitting a bid or proposal to the Village of Downers Grove shall be required to submit with its bid submission, an executed Campaign Disclosure Certificate.

The Campaign Disclosure Certificate is required pursuant to the Village of Downers Grove Council Policy on Ethical Standards and is applicable to those campaign contributions made to any member of the Village Council.

Said Campaign Disclosure Certificate requires any individual or entity bidding to disclose campaign contributions, as defined in Section 9-1.4 of the Election Code (10 ILCS 5/9-1.4), made to current members of the Village Council within the five (5) year period preceding the date of the bid or proposal release.

By signing the bid documents, contractor/proposer/bidder/vendor agrees to refrain from making any campaign contributions as defined in Section 9-1.4 of the Election Code (10 ILCS 5/9-1.4) to any Village Council member and any challengers seeking to serve as a member of the Downers Grove Village Council.

Under penalty of perjury, I declare:

Bidder/vendor has not contributed to any elected Village position within the last five (5) years.

[Signature]
Signature

David J. Decker
Print Name

Bidder/vendor has contributed a campaign contribution to a current member of the Village Council within the last five (5) years.

Print the following information

Name of Contributor: _____
(company or individual)

To whom contribution was made: _____

Year contribution made: _____ Amount: \$ _____

Signature

Print Name

AGENDA MEMO
Municipal Services Committee
April 25, 2016

ISSUE STATEMENT

A resolution authorizing the purchase of one new Factory Cat 24-inch Scrubber/Sweeper from Factory Cleaning Equipment in an amount not to exceed \$6,600.

BACKGROUND/HISTORY

The proposed walk behind floor scrubber would allow the department to keep the garage floor at the Public Works facility clean of oil and grime. The garage floor was re-coated last year with an epoxy commercial floor covering and the scrubber would allow the department to maintain the floor.

Staff requested competitive quotes and received the following quotes:

VENDOR	UNIT COST
Atlas Companies	\$ 8,056.00
Factory Cleaning Equipment	\$ 6,600.00
Tenant Company	\$ 7,547.25

The proposed expenditure would be expended from the following line accounts:

ACCOUNT NUMBER	ACCOUNT DESCRIPTION	FY 16-17 BUDGET	PROPOSED EXPENDITURE	PROPOSED BALANCE
02-50-4225	MAINTENANCE EQUIPMENT GARAGE FLOOR SWEEPER	\$ 3,300	\$ 3,300	\$ -0-
01-30-4225	MAINTENANCE EQUIPMENT GARAGE FLOOR SWEEPER	\$ 3,300	\$ 3,300	\$ -0-

STAFF RECOMMENDATION

Staff recommends approval of the resolution authorizing the purchase one new Factory Cat 24-inch Scrubber/Sweeper from Factory Cleaning Equipment in an amount not to exceed \$6,600.

ALTERNATE DECISION

As recommended by the Committee.

DECISION MODE

This item will be on the May 2, 2016 City Council agenda for formal consideration.

RESOLUTION NO. _____

A RESOLUTION AUTHORIZING THE MAYOR AND CITY CLERK TO ACCEPT A PROPOSAL FOR THE PURCHASE OF ONE NEW FACTORY CAT 24-INCH SCRUBBER/SWEEPER FROM FACTORY CLEANING EQUIPMENT IN AN AMOUNT NOT TO EXCEED \$6,600.00

BE IT RESOLVED BY THE CITY COUNCIL OF THE CITY OF DARIEN, DU PAGE COUNTY, ILLINOIS, as follows:

SECTION 1: The City Council of the City of Darien hereby authorizes the Mayor and City Clerk to accept a proposal for the purchase of one new Factory Cat 24-inch scrubber/sweeper from Factory Cleaning Equipment in an amount not to exceed \$6,600.00, a copy of which is attached hereto as "**Exhibit A**".

SECTION 2: This Resolution shall be in full force and effect from and after its passage and approval as provided by law.

PASSED BY THE CITY COUNCIL OF THE CITY OF DARIEN, DU PAGE COUNTY, ILLINOIS, this 2nd day of May, 2016.

AYES: _____

NAYS: _____

ABSENT: _____

APPROVED BY THE MAYOR OF THE CITY OF DARIEN, DU PAGE COUNTY, ILLINOIS, this 2nd day of May, 2016.

KATHLEEN MOESLE WEAVER, MAYOR

ATTEST:

JOANNE E. RAGONA, CITY CLERK

APPROVED AS TO FORM

CITY ATTORNEY

Factory Cleaning Equipment
1578 Beverly Ct.
Aurora IL 60502
800-793-3790

City of Darien
1702 Plainfield Rd.
Darien IL 60561
Attn: David Fell

April 4th, 2016

New Model Factory Cat MiniMag Cylindrical Scrubber/Sweeper

- 24" Scrub Path
- Transmission Drive
- Cylindrical Scrub Brush System
- 17 Gallon Solution
- 17" Recovery Tank
- 24 Volt System
- Drain Saver
- Hygenic Tanks
- 3/16" Coated Steel Frame
- 3/8" Thick Poly Tanks
- 3.5 Hour Run Time
- 3 Years Parts 1 Year Labor Warranty
- Light Grit Brush
- Squeegee Width-32"



Price New...
Subject To Tax

\$ 6,500.00

Freight...

\$ 100.00

60 Month Financing
\$ 140.00/Month
Subject to Tax & Credit Approval
\$ 1.00 Purchase Option

6,600.00

Authorized Acceptance
Terms Agreed To _____

Purchase Order

Quoted By Greg Arndt
Cell Phone # 630-542-0758
Email: greg@thesweeper.com

TERMS AND CONDITIONS

1. All machine purchases are sold on Cash on Delivery Basis.
2. If payment terms are extended, use of the equipment is considered a rental unit until paid in full. Should the customer default on payment of the equipment, they agree to pay Factory Cleaning Equipment's regular published rental rates for the type of machine purchased for the time it is in their possession.
3. Payment for rental is due upon surrender of the equipment.
4. Factory Cleaning Equipment reserves the right to repossess the equipment should the customer default on payment terms.
5. Late payment will result in an interest charge of 1.5% per month on all unpaid balances.
6. Factory Cleaning Equipment warrants equipment only to the extent of the manufacturers warranty. No other warranties are expressed or implied.

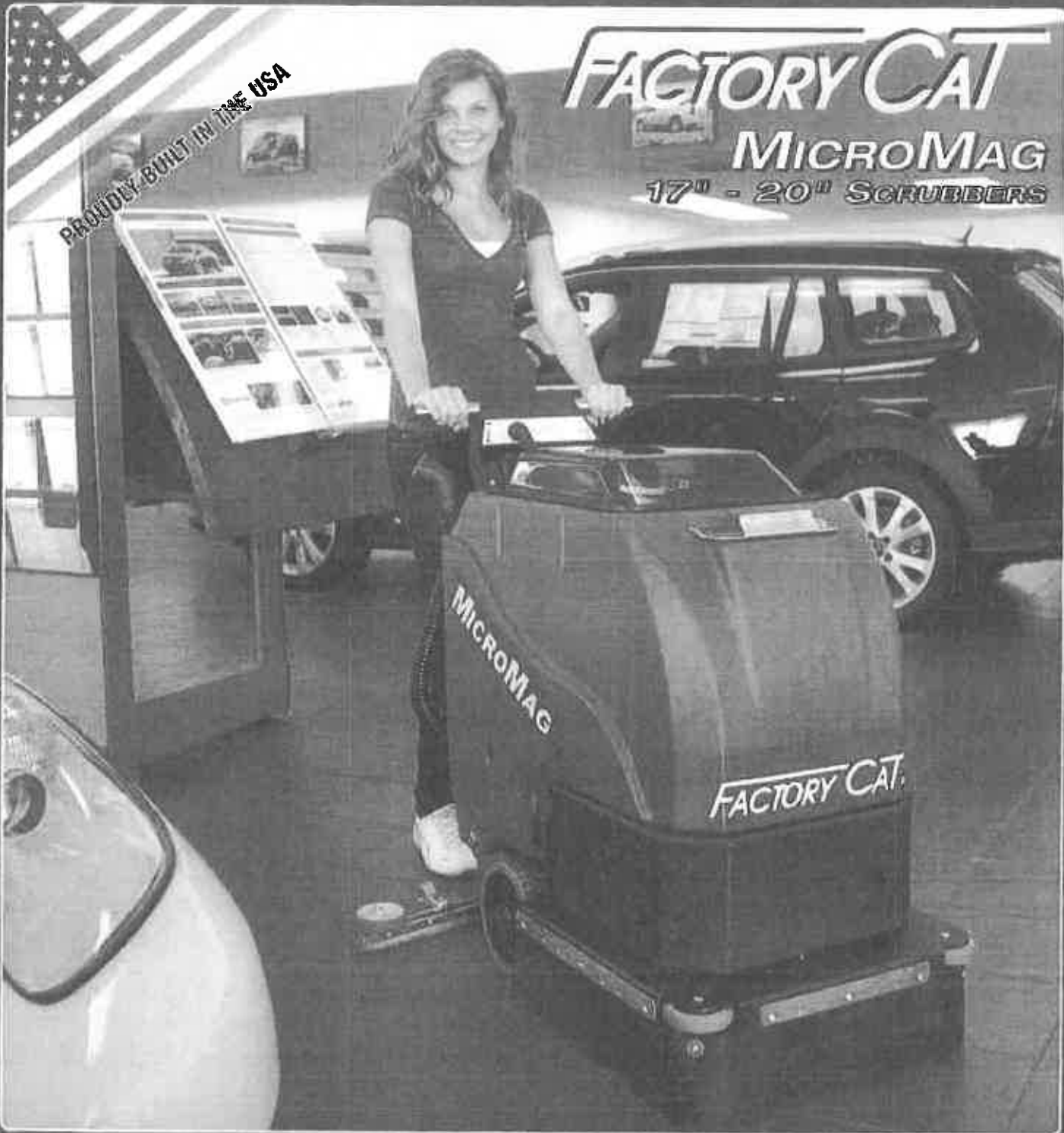

PROUDLY BUILT IN THE USA

FACTORY CAT

MICROMAG

17" - 20" SCRUBBERS

FAMILY OF INDUSTRIAL CLEANING EQUIPMENT



CONCRETE POLISHING



FACTORY CAT's ultra compact **Micromag** scrubbers are designed to clean machine shops, congested lunch rooms, car dealerships and busy fabrication plants. They stand up to the demands of daily industrial use, including rough tractor trailer service bays.

The **Micromag** is available as a Pad Assist (**Micro**) or Traction (**Micromag**). The 10 gallon tanks and standard batteries offer superior productivity. Built to the same high standard as our largest rider scrubbers, the **Micromag** has the ability to remove tire marks and heavy buildup. It's simple design is ideal for the "Do it Yourself" operators and service staff.

The disk models are available in 17" and 20" sizes, and our pad assist design offers unmatched propulsion. This adjustable pad bias is unique to **FACTORY CAT** and allows the machine to be almost completely self propelled on most floor surfaces.

The traction drive units have a powerful all-gear transaxle for climbing ramps and operator ease. The curved squeegee is laser cut from 3/4" steel and includes a "break-away" design for durability.

Operators of various heights will appreciate the adjustable handlebar, and low hood for superior visibility.

The scrub head is protected by the frame's heavy steel construction, with non-marking tires and bumper wheels to protect against marks. Like other **FACTORY CAT** equipment, the **Micromag** is entirely **MADE** in the USA, and with American components that are assembled with stainless fasteners.

On close inspection you will notice that axle, casters, scrub deck, squeegee linkage and battery package all mounted directly to a 10 gauge steel frame, which is powder coated for protection.

www.factorycat.com

Call (800) 634-4060 for a Demonstration



**POWERFUL
CLEANING
CUTS GREASE**



**CLEANABLE
RECOVERY
TANK FOR
SANITIZING**



**BASKET
ELIMINATES
CLOGGED
FLOOR DRAINS**

COMPACT SIZE ALLOWS USE IN NARROW AISLES & SERVICE BAYS



MICROMAG

Adjustable Stainless Handlebar
Operator Comfort

Transparent Lid
Gives operator view into tank

Tank Baffle Separates Recovery Tank
Protects Vac motor from foam

Open Recovery Tank
Access for Sanitation

Stainless Drain Saver
Eliminates clogged drains

Standard 350 lb. Actuator
Operator Ergonomics

Isolated Vac Motor
Quiet Operation

American Made Motors
Performance & long life

Brass Valve/Stainless Filter
Easy maintenance

Optional 1.0 hp Motor
30% scrubbing power

Powder Painted Steel Frame
Protects scrub deck

Frame, Caster & Deck Curtains
Water control & reduced service

Non-Marking tires and casters
Eliminate skid marks

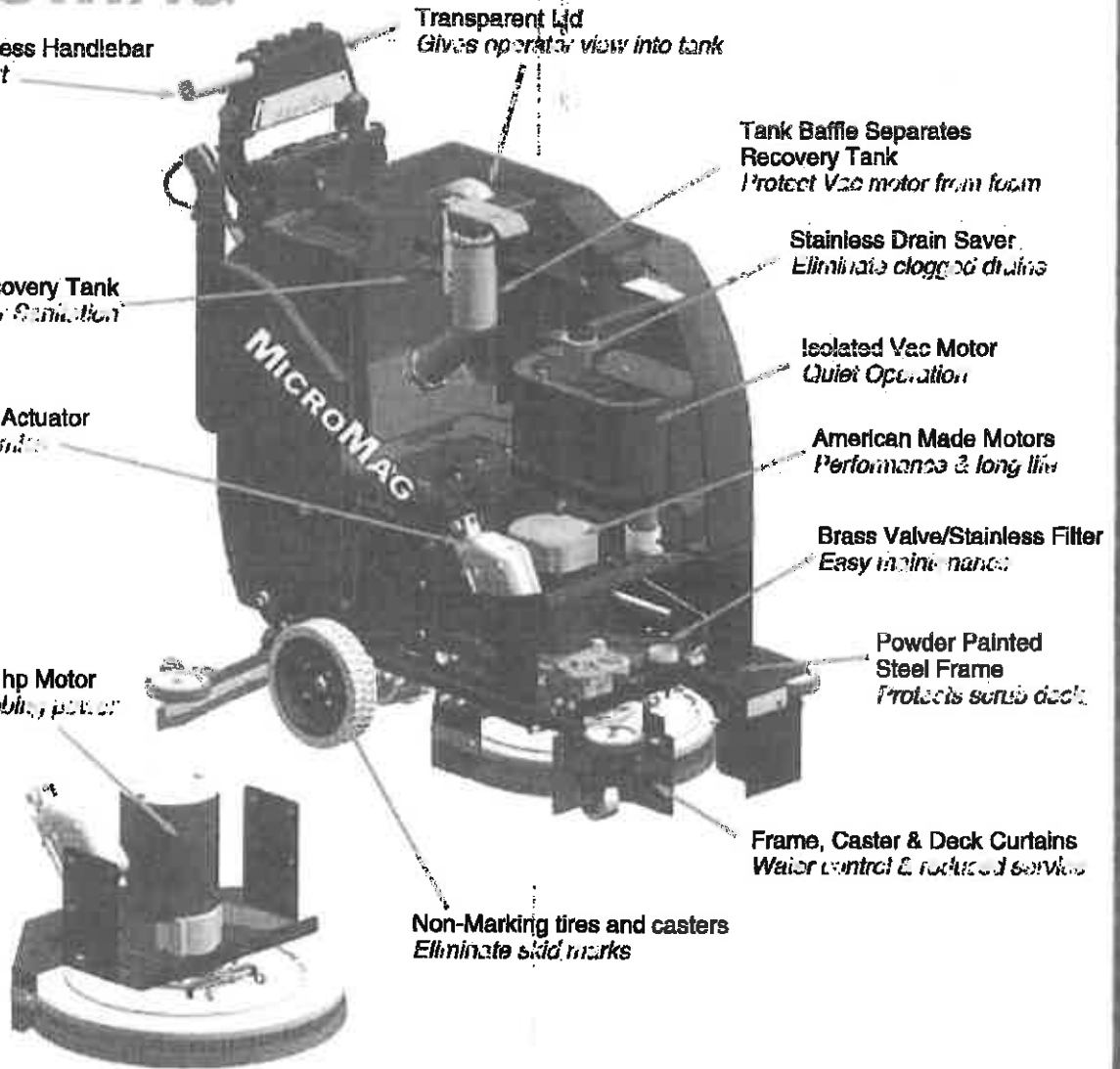

TANK TIPS BACK FOR EASY ACCESS TO:



- Filters
- Valves
- Motors
- Vacuum
- Batteries
- Actuator



RETURN ON INVESTMENT

AREA	TIME REQUIRED TO CLEAN		
	Sq. Ft.	By Hand	Model MicroMag 20 [®]
10,000	7 hrs	0.5 hrs	\$ 220.00
25,000	17 hrs	1.5 hrs	\$ 550.00
50,000	50 hrs	3.0 hrs	\$1,650.00

SOLD THROUGH DISTRIBUTORS

We've built our reputation by providing the toughest, best-engineered, highest-value machines our industry can produce. We make sure that in every market in which our more than 350 distributors in 36 countries and service centers do business, they maintain a "factory" trained service department with a vested interest in our customers long-term satisfaction.

Factory Cat offers a line of cleaning equipment that includes sweepers and scrubbers, in both walk-behind and ride on models. All our models are practical, rugged machines that are sensibly priced. Your local dealer will be happy to assist you with rentals, soap, and floor sealer information. They will gladly provide service on all brands of cleaning equipment.

AUTHORIZED DISTRIBUTOR



Manufactured By:
R.P.S. Corporation
 P.O. Box 368
 Racine, Wisconsin 53401
 Phone: (800) 634-4060
 International: 011 262 681 5747
 Fax: (866) 901-3335
www.factorycat.com



Copyright R.P.S. Corporation 2011. All rights reserved. Since our policy is one of constant improvement, all specifications are subject to change without notice or penalty.

Micro 17", 20" (43, 51 cm)	MicroMag 17", 20" (43, 51 cm)
---	--

Body Construction/Dimensions

Tank Material:	Poly (5/16" thick) (7.9 cm)	Poly (5/16" thick) (7.9 cm)
Chassis Construction:	1/8" Coated Steel (3.2 cm)	1/8" Coated Steel (3.2 cm)
Rear Wheels:	(2) 8" x 2" (51.0 x 5.1 cm)	(2) 8" x 3" (51.0 x 7.6 cm)
Front Casters:	(2) 2.5" x 1.38" (6.35 x 3.5 cm)	(2) 2.5" x 1.38" (6.35 x 3.5 cm)
Size (L x W x H):	37" x 18" x 38" (94.0 x 45.7 x 97 cm)	40" x 18" x 38" (101.6 x 45.7 x 97 cm)
Weight (w/o batteries):	115 lbs. (52 kg)	152 lbs. (69 kg)
Weight (w/batteries):	298 lbs. (135 kg)	317 lbs. (144 kg)

Brush System

Disk Brush/Pad Size:	17-D: (1) 17" (43 cm) 20-D: (1) 20" (51 cm)	17-D: (1) 17" (43 cm) 20-D: (1) 20" (51 cm)
Disk Brush Motor:	(1) .75 hp (559 watts)/200 rpm	(1) .75 hp (559 watts)/200 rpm
Optional Brush Motor:	(1) 1.0 hp (746 watts)/200 rpm	(1) 1.0 hp (746 watts)/200 rpm
Brush Down Pressure:	0-75 lbs. (0-34 kg)	0-125 lbs. (0-57 kg)

Battery System

System Voltage:	24 volts	24 volts
Standard Battery Rating:	85 ah	85 ah
Optional Battery Rating:	Up to 130 ah	Up to 130 ah
Battery Run Time:	Up to 3 hours	Up to 3 hours
Charger (110/60 Hz/24 volt):	8 amp Dual Mode Console	8 amp Dual Mode Console

Solution System

Solution Tank Capacity:	10 gallons (38 liters)	10 gallons (38 liters)
Solution Flow Rate:	0-.5 gpm (0-2 lpm)	0-.5 gpm (0-2 lpm)
Solution Filter:	Stainless/inline	Stainless/inline

Recovery System

Recovery Tank Capacity:	10 gallons (38 liters)	10 gallons (38 liters)
Vacuum Power:	0.75 hp (559 watts)	0.75 hp (559 watts)
Drain Hose:	1.5" diameter (4 cm)	1.5" diameter (4 cm)
Vacuum Specs. (#1/inflow):	70"/70 cfm (17.8 cm/21 cfm)	70"/70 cfm (17.8 cm/21 cfm)
Demisting Chamber:	1.25 gallons (5 liters)	1.25 gallons (5 liters)
Drain Saver:	30 cubic inches (70 cubic cm)	30 cubic inches (70 cubic cm)

General

Cleaning Width:	17-BD: 17" (43 cm) 20-BD: 20" (51 cm)	17-D: 17" (43 cm) 20-D: 20" (51 cm)
Cleaning Rate/Hour (sq. ft/hr):	Up to 18,474 (1,693 m ²)	Up to 20,525 (1,900 m ²)
Sound Level:	67 dBA	67 dBA

Drive System

Standard Drive:	Adjustable Pad Assist	0.4 hp (298 watts), all gear/sealed
Forward Speed:	NA	0-230 ft/min (4 mph) (0.7 h)
Reverse Speed:	NA	0-130 ft/min (2 mph) (0.4 h)
Options:	Maintenance Remote Spray Hose	Free Batteries

AGENDA MEMO
Municipal Services Committee
April 25, 2016

ISSUE STATEMENT

A resolution authorizing the purchase of one new EnviroSight Quickview Air HD Pipeline Camera, X8500 from Standard Equipment in an amount not to exceed \$15,000.00

BACKGROUND/HISTORY

The proposed camera will allow the department to televise existing storm sewers to determine whether further maintenance or replacement is required. The preventative maintenance is essential prior to a road resurfacing project and would allow Staff to document field conditions for budgeting purposes. The camera would also be utilized to inspect storm sewers within easements for blockages and/or spot maintenance due to collapsed infrastructure. The department will realize a cost savings with the camera as outsourced televising may not be required. Please note the department will continue to require limited outsourced televising for certain situations.

Staff received competitive quotes and received the following:

VENDOR	COST
A & H Equipment	\$15,475.00
Envirosight	\$15,257.00
<i>Standard Equipment</i>	<i>\$15,000.00</i>

Standard Equipment was the selected vendor and will supply the equipment. Attached and labeled as Attachment A, pages 1-5, is information regarding the cost breakdown and specifications for the proposed equipment. Upon approval of the EnviroSight Quickview Air HD Pipeline Camera X8500, a compatible touchscreen tablet will be purchased and dedicated to the pipeline camera.

The proposed expenditure would be expended from the following line accounts:

ACCOUNT NUMBER	ACCOUNT DESCRIPTION	FY 16-17 BUDGET	PROPOSED EXPENDITURE	PROPOSED BALANCE
01-30-4815	CAPITAL PURCHASES-QUICK VIEW SEWER CAMERA	\$ 16,000	\$ 15,000.00	\$ 1,000.00

STAFF RECOMMENDATION

Staff recommends approval of the resolution authorizing the purchase one EnviroSight Quickview Air HD Pipeline Camera, X8500 from Standard Equipment in an amount not to exceed \$15,000.

ALTERNATE DECISION

As recommended by the Committee.

2016 HD Pipeline Camera
April 25, 2016
Page 2

DECISION MODE

This item will be on the May 2, 2016 City Council agenda for formal consideration.



Mr. Dave Feil
Street Division Foreman
City of Darien
1041 South Frontage Road
Darien, Illinois 60561

April 6, 2016

Dear Mr. Feil,

Standard Equipment Company is pleased to present the following quote on an Envirosight Quickview AIR HD zoom pipeline inspection system with equipment as shown. Please note that this quote is valid for 30 days from today's date.

ENVIROSIGHT QUICKVIEW AIR HD TO INCLUDE:

Quad LED Haloptic lighting camera head
Battery operated
Shipping case
HD Video
Hands free stability
Payment upon delivery

App based from tablet (not included)
16' Bi-pod pole
Wi-Fi Wirelessly controlled
Motorized tilt
Remote Centering
Onsite maintenance/training

FOR THE AMOUNT OF:

\$15,000

Thank you for the opportunity to quote you on your sewer televising needs. Please contact me at (312) 208-6377 if you need any additional information.

Best Regards,

STANDARD EQUIPMENT COMPANY

Jim Miller
Account Manager



April 1st, 2016

RE: Standard Equipment Company

Dear Sir or Madam,

Envirosight, LLC has worked very hard to align itself with the premier distributors in the underground infrastructure maintenance equipment industry. To that end, we have partnered with Standard Equipment Company in the State of Illinois to provide our customers equipment, parts, and after sale service.

Standard Equipment Company is the sole contractual provider of Envirosight products and service in and for the State of Illinois. This includes, but is not limited to, our Rover, Rover X, and Supervision robotic camera systems, Quickview zooming and manhole inspection system, the Quickview Haloptic zooming inspection system, Jetscan video nozzles, Verisight push camera systems and Digisewer sidewall scanning and evaluation technology.

Thank you and please feel free to contact me with any questions or concerns that may arise.

Best regards,

Mike Vislay
VP of Sales
Envirosight, LLC
412-216-8701



insight
unleashed

 **quickview**
RTHD

an instant,
wireless view
into any sewer

EN virosight



sewer
assessment
that unleashes
your insight

A complete sewer assessment is essential to prioritizing CCTV and maintenance activities, planning cleaning and rehab work, and meeting regulatory obligations.

Quickview airHD makes it easier, faster and more affordable to assess sewer condition, offering productivity features like:

- HD video
- wireless operation
- touchscreen controls
- integrated tilt
- hands-free stability
- remote centering

Quad Haloptik: Our patented Haloptik technology gives you more illumination farther into the pipe with optimum alignment at every distance. The new Quad Haloptik configuration uses four offset reflector/lamp pairs to fully encircle the camera with powerful light.



HALO

Smart Center: To adjust camera height in-manhole, push against the standoff's gas spring to the desired height; a ratchet then holds your position.



camera



Wireless control and video eliminate cables and allows for video sharing on multiple devices



Connection: Connect to any Quickview airHD in range, either in control or view-only mode. Download app updates to access new features.

Status Bar: Monitor illumination, zoom and tilt, as well as Wi-Fi signal and battery (for both tablet and camera).

Capture: Record video and capture still images to the media library.



controls

Text Overlays: Configure on-screen display of text, including variables like zoom, tilt and GPS coordinates. Modify text color and position.

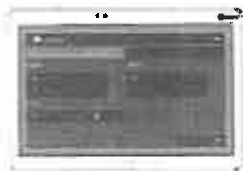

Media Library: Browse media thumbnails, then review, annotate and share footage.



©2016 by iQIPOINT, LLC. All rights reserved. Specifications subject to change without notice. The Quickview, Halo, Haloptik and logo are trademarks of iQIPOINT, LLC. Patents 6,538,732 and 7,839,698; others pending.

Video edit
camera Resolu
compatible Gator



system components

- camera head
- pole
- standoff
- bipod
- battery (2)
- battery charger
- case
- app (tablet device not included)



www.envirosight.com
 (866) 936-8476 • (973) 252-6700
 111 Canfield Ave., Unit B3
 Randolph, NJ 07869

specifications

video system

imager 1/2.8-type CMOS
 zoom 360x (30x optical, 12x digital)
 resolution 1280x720 pixels (2.38 megapixels)
 functions ZOOM
 focus (auto/manual)
 shutter (auto/manual)
 sensitivity mode
 field of view (hor.) 63.7 deg (wide) - 2.3 deg (tele)
 sensitivity 1.4 LUX

illumination

system Quad Haloptic (four LED/reflector pairs)
 illumination type coaxial, collimated
 reflector type proprietary

camera head

connections 4-pin auxiliary port
 depth rating 10' (3m)
 construction aluminum, rubber, acrylic
 sensors temperature, pressure, incline

wireless system

Wi-Fi standard IEEE 802.11b/g/n
 frequency range 2.400-2.483 GHz
 operating channels 1-11

centering support

extension range 18.9" (480mm)
 pipe diameter compatibility 6-48" (DIN 150-1200)
 mechanism gas spring with reciprocating ratchet

battery/charger

battery quantity 2
 battery capacity 3.4 A-hr.
 battery charger mains power

pole/bipod

length (collapsed/extended) 4'/16' (nominal)
 stabilization detachable hands-free support

app

supported OS Android, iOS, Windows

worldwide sales, service and support offices

RESOLUTION NO. _____

A RESOLUTION AUTHORIZING THE MAYOR AND CITY CLERK TO ACCEPT A PROPOSAL FOR THE PURCHASE OF ONE NEW ENVIROSIGHT QUICKVIEW AIR HD PIPELINE CAMERA, X8500 FROM STANDARD EQUIPMENT IN AN AMOUNT NOT TO EXCEED \$15,000.00

BE IT RESOLVED BY THE CITY COUNCIL OF THE CITY OF DARIEN, DU PAGE COUNTY, ILLINOIS, as follows:

SECTION 1: The City Council of the City of Darien hereby authorizes the Mayor and City Clerk to accept a proposal for the purchase of one new EnviroSight Quickview Air HD Pipeline Camera, X8500 from Standard Equipment in an amount not to exceed \$15,000.00, a copy of which is attached hereto as "**Exhibit A**".

SECTION 2: This Resolution shall be in full force and effect from and after its passage and approval as provided by law.

PASSED BY THE CITY COUNCIL OF THE CITY OF DARIEN, DU PAGE COUNTY, ILLINOIS, this 2nd day of May, 2016.

AYES: _____

NAYS: _____

ABSENT: _____

APPROVED BY THE MAYOR OF THE CITY OF DARIEN, DU PAGE COUNTY, ILLINOIS, this 2nd day of May, 2016.

KATHLEEN MOESLE WEAVER, MAYOR

ATTEST:

JOANNE E. RAGONA, CITY CLERK

APPROVED AS TO FORM

CITY ATTORNEY



Mr. Dave Fell
Street Division Foreman
City of Darien
1041 South Frontage Road
Darien, Illinois 60561

April 6, 2016

Dear Mr. Fell,

Standard Equipment Company is pleased to present the following quote on an EnviroSight Quickview AIR HD zoom pipeline inspection system with equipment as shown. Please note that this quote is valid for 30 days from today's date.

ENVIROSIGHT QUICKVIEW AIR HD TO INCLUDE:

Quad LED Haloptic lighting camera head
Battery operated
Shipping case
HD Video
Hands free stability
Payment upon delivery

App based from tablet (not included)
16' BI-pod pole
Wi-Fi Wirelessly controlled
Motorized tilt
Remote Centering
Onsite maintenance/training

FOR THE AMOUNT OF:

\$15,000

Thank you for the opportunity to quote you on your sewer televising needs. Please contact me at (312) 208-6377 if you need any additional information.

Best Regards,

STANDARD EQUIPMENT COMPANY

Jim Miller
Account Manager



April 1st, 2016

RE: Standard Equipment Company

Dear Sir or Madam,

Envirosight, LLC has worked very hard to align itself with the premier distributors in the underground infrastructure maintenance equipment industry. To that end, we have partnered with Standard Equipment Company in the State of Illinois to provide our customers equipment, parts, and after sale service.

Standard Equipment Company is the sole contractual provider of Envirosight products and service in and for the State of Illinois. This includes, but is not limited to, our Rovver, Rovver X, and Supervision robotic camera systems, Quickview zooming and manhole inspection system, the Quickview Haloptic zooming inspection system, Jetscan video nozzles, Verisight push camera systems and Digisewer sidewall scanning and evaluation technology.

Thank you and please feel free to contact me with any questions or concerns that may arise.

Best regards,

Mike Vislay
VP of Sales
Envirosight, LLC
412-216-8701



insight
unleashed

 **quickview**[®]
HD

an instant,
wireless view
into any sewer

EN virosight



sewer assessment that unleashes your insight

A complete sewer assessment is essential to prioritizing CCTV and maintenance activities, planning cleaning and rehab work, and meeting regulatory obligations.

Quickview aHD makes it easier, faster and more affordable to assess sewer condition, offering productivity features like:

- HD video
- wireless operation
- touchscreen controls
- motorized tilt
- hands-free stability
- remote setting

Quad Haloptic. Our patented Haloptic technology gives you more illumination farther into the pipe with optimum alignment at every distance. The new Quad Haloptic configuration uses four offset reflector/lamp pairs to fully encircle the camera with powerful light.

HALD

Smart Center. To adjust camera height, fit in-manhole, push against the standoff's gas spring to the desired height; a ratchet then holds your position.

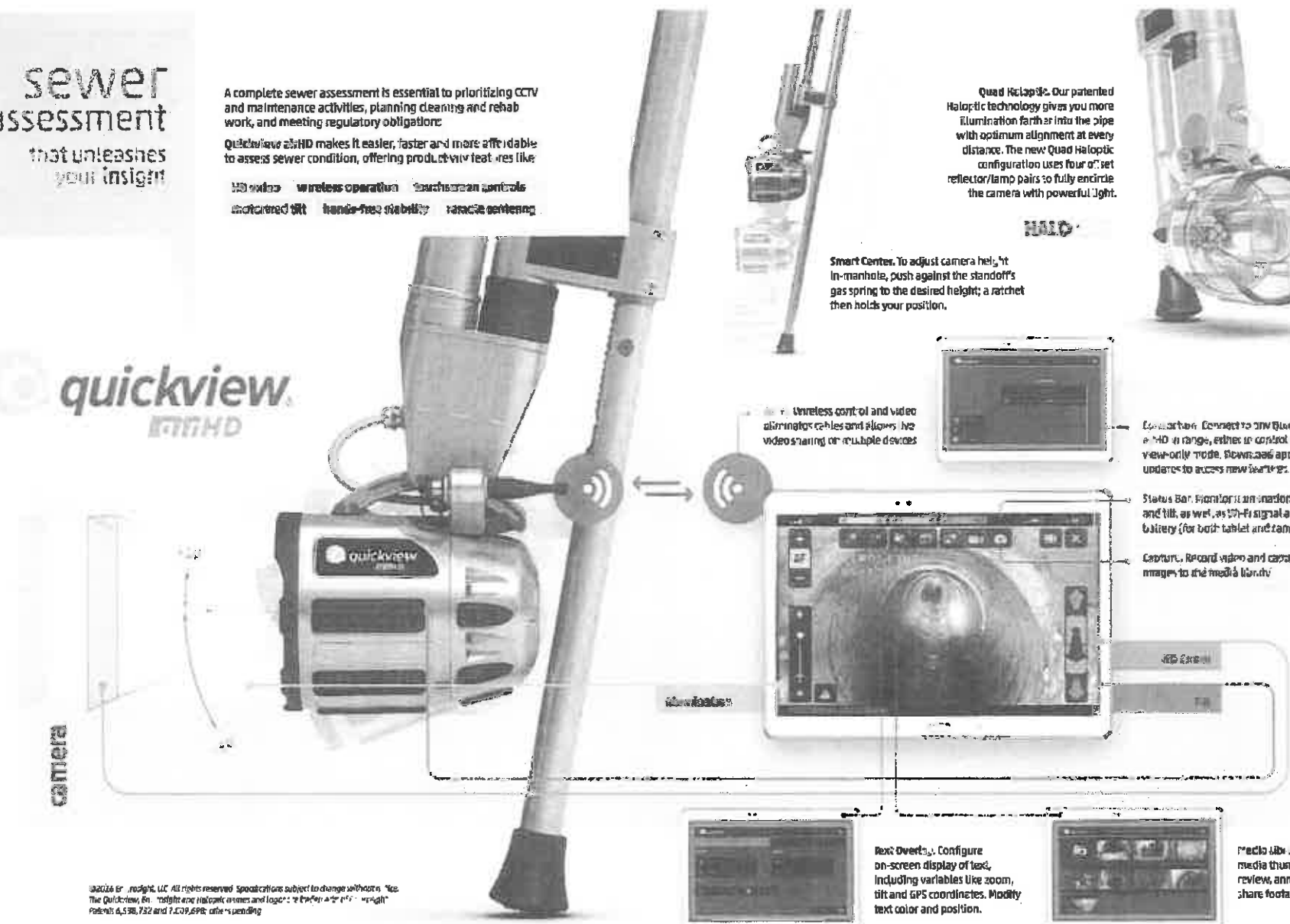

Wireless control and video eliminates cables and allows live video sharing on multiple devices.

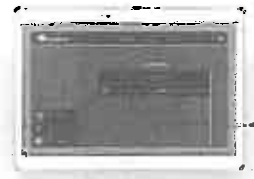

Connection. Connect to the Quickview aHD in range, either in control or view-only mode. Shows app updates to access new features.

Status Bar. Monitor connection, zoom and tilt, as well as Wi-Fi signal and battery (for both tablet and camera).

Controls. Record video and capture still images to the media library.



HD Screen

controls



Text Overlays. Configure on-screen display of text, including variables like zoom, tilt and GPS coordinates. Modify text color and position.



Media Library. Browse media thumbnails, then review, annotate and share footage.

©2016 by i-rodigit, LLC. All rights reserved. Specifications subject to change without notice. The Quickview, fit, insight and Haloptic names and logos are trademarks of i-rodigit. Patents 6,536,732 and 7,609,698; other pending.

Video edit
camera Resolu
compatible. Gater.



system components

- camera head
- pole
- standoff
- bipod
- battery (2)
- battery charger
- case
- app (tablet device not included)



www.envirosight.com

(866) 936-8476 • (973) 252-6700

111 Canfield Ave., Unit B3
Randolph, NJ 07869

specifications

video system

Imager 1/2.8-type CMOS
 zoom 360x (30x optical, 12x digital)
 resolution 1280x720 pixels (2.38 megapixels)
 functions zoom
 focus (auto/manual)
 shutter (auto/manual)
 sensitivity mode
 field of view (hor.) 63.7 deg (wide) - 2.3 deg (tele)
 sensitivity 1.4 lux

illumination

system Quad Haloptic (four LED/reflector pairs)
 illumination type coaxial, collimated
 reflector type proprietary

camera head

connections 4-pin auxiliary port
 depth rating 10' (3m)
 construction aluminum, rubber, acrylic
 sensors temperature, pressure, incline

wireless system

Wi-Fi standard IEEE 802.11b/g/n
 frequency range 2.400-2.483 GHz
 operating channels 1-11

centering support

extension range 18.9" (480mm)
 pipe diameter compatibility 6-48" (DIN 150-1200)
 mechanism gas spring with reciprocating ratchet

battery/charger

battery quantity 2
 battery capacity 3.4 A-hr.
 battery charger mains power

pole/bipod

length (collapsed/extended) 4'/16' (nominal)
 stabilization detachable hands-free support

app

supported OS Android, iOS, Windows

AGENDA MEMO
Municipal Services Committee
April 25, 2016

ISSUE STATEMENT

A resolution authorizing the purchase of one new RD8100 PXL Series Precision Location System Package-Water Main Locator from Associated Technical Services in an amount not to exceed \$7,868.

BACKGROUND/HISTORY

The proposed line locator would be replacing a 2011 RD8000 PDL/RD-TX10 pipe line locator. The current model is out of warranty and continues to require service for calibration and holding a battery charge. The precision equipment is utilized on a daily basis, including emergencies to locate water mains and water services.

The RD8100 PXL pipe line locator is at the top of the field in line locating technology and equipment. The new model has improved ergonomics and a technological feature that allows the operator to lock in onto the water main or service, therefore providing accurate locates. The lock in ability eliminates the risk of a signal bleeding onto another utility and mis-locating the City's utility.

Staff requested competitive quotes and received the following quotes:

VENDOR	UNIT COST
<i>Associated Technical Services</i>	\$ 7,868
Subsurface Solutions	\$ 8,091
Radio Detection	\$ 7,895

The proposed expenditure would be expended from the following line account:

ACCOUNT NUMBER	ACCOUNT DESCRIPTION	FY 16-17 BUDGET	PROPOSED EXPENDITURE	PROPOSED BALANCE
02-50-4815	CAPITAL PURCHASES WATER MAIN LINE LOCATOR	\$ 8,500	\$ 7,868	\$ 632.00

STAFF RECOMMENDATION

Staff recommends approval of the resolution authorizing the purchase of one new of one new RD8100 PXL Series Precision Location System Package from Associated Technical Services in an amount not to exceed \$7,868.

ALTERNATE DECISION

As recommended by the Committee.

2016 RD8100 PXL
April 25, 2016
Page 2

DECISION MODE

This item will be on the May 2, 2016 City Council agenda for formal consideration.

RESOLUTION NO. _____

A RESOLUTION AUTHORIZING THE MAYOR AND CITY CLERK TO ACCEPT A PROPOSAL FOR THE PURCHASE OF ONE NEW RD8100 PXL SERIES PRECISION LOCATION SYSTEM PACKAGE – WATER MAIN LOCATOR FROM ASSOCIATED TECHNICAL SERVICES IN AN AMOUNT NOT TO EXCEED \$7,868

BE IT RESOLVED BY THE CITY COUNCIL OF THE CITY OF DARIEN, DU PAGE COUNTY, ILLINOIS, as follows:

SECTION 1: The City Council of the City of Darien hereby authorizes the Mayor and City Clerk to accept a proposal for the purchase of one new RD8100 PXL Series Precision Location System Package – Water Main Locator from Associated Technical Services in an amount not to exceed \$7,868.00, a copy of which is attached hereto as “**Exhibit A**”.

SECTION 2: This Resolution shall be in full force and effect from and after its passage and approval as provided by law.

PASSED BY THE CITY COUNCIL OF THE CITY OF DARIEN, DU PAGE COUNTY, ILLINOIS, this 2nd day of May, 2016.

AYES: _____

NAYS: _____

ABSENT: _____

APPROVED BY THE MAYOR OF THE CITY OF DARIEN, DU PAGE COUNTY, ILLINOIS, this 2nd day of May, 2016.

KATHLEEN MOESLE WEAVER, MAYOR

ATTEST:

JOANNE E. RAGONA, CITY CLERK

APPROVED AS TO FORM

CITY ATTORNEY

ASSOCIATED TECHNICAL SERVICES LTD



524 W. ST. CHARLES RD VILLA PARK, IL 60181

www.ATSLIMITED.com

Office: 630.834.1558 / Fax: 630.834.5501

April 13, 2016

City of Darien
1041 S. Frontage Road
Darien, Illinois 60561

Attn: Mr. Kris Throm
Water Department Foreman

RE: Price Quotation for Radiodetection
RD-B100 Utility Location System

Dear Mr. Throm,

We are pleased to present the following information and a proposal to provide the City of Darien with a new **RADIODETECTION RD-B100 Series "HIGH PERFORMANCE UTILITY LOCATION SYSTEM"**. Radiodetection makes the most versatile locators in the world. You have a choice of powerful transmitters. Optional components let you handle **Sewer Line Locating, Sewer Blockage Pinpointing, Electric Current Measurement & Direction, Cable Fault Finding.**

With any **RD-B100 System** you will be able to trace water, sewer, gas, electric, cable, & telecommunication lines with consistent accuracy. **Optional Systems Upgrades** will increase tracing power or add fault finding capabilities. This innovative system offers the greatest combination of lightweight ergonomic design, versatility, value and performance of any locator on the market. It is the ultimate in high performance location systems that you can grow with plus add accessories for more tracing capabilities as your needs and skills develop further.

"RD-B100 PXL Series Precision Location System Package (Fault Finding Capability)"

"RD-B100 PXL / RD-TX10 Package"

RD-B100 PXL Receiver:	\$ 3,054.00
RD-TX10 10-Watt, 15 Active, 8 Inductive Frequencies	\$ 2,473.00
4" Signal Clamp	\$ 371.00
Transmitter Li-Ion Rechargeable Battery Pack Includes AC Main and 12V DC Charger and Leads	\$ 830.00
Spare Transmitter Li-Ion Rechargeable Battery Pack	\$ 357.00
Receiver Li-Ion Rechargeable Battery Pack Includes AC Main and 12V DC Charger and Leads	\$ 501.00
Spare RD Receiver Rechargeable Battery Pack	\$ 199.00
Hard Carry Case for the RD-B100 model	\$ 383.00
Cost for this System:	\$ 7,783.00
SHIPPING/Insured for this system:	\$ 85.00*
Final Cost:	\$ 7,868.00

*Adding additional Equipment or accessories will change the amount of shipping

PROFESSIONAL HIGH TECHNOLOGY SERVICES

EMERGENCY LEAK PINPOINTING • LEAK DETECTION SURVEYS • UNDERGROUND UTILITY LOCATION • GIS / GPS MAPPING
VALVE EXERCISING • CCTV PIPE INSPECTIONS • HYDRANT TESTING • WATERMAIN FLUSHING • EQUIPMENT SALES & TRAINING

Optional Upgrades to Base Location System: Add to Base System Cost

RF Marker Balls (Case of 24) Designate Utility Type	Add	\$ 228.00
Transmitter Li-Ion Rechargeable Battery Pack Includes AC Main and 12V DC Charger and Leads	Add	\$ 535.00
Spare Transmitter Li-Ion Rechargeable Battery Pack	Add	\$ 357.00
Receiver Li-Ion Rechargeable Battery Pack Includes AC Main and 12V DC Charger and Leads	Add	\$ 501.00
Spare RD Receiver Rechargeable Battery Pack	Add	\$ 203.00
RD-TX Series Transmitter 8.5" Signal Clamp	Add	\$ 783.00
RD-TX Series Transmitter Live Cable Connector	Add	\$ 395.00
RD-TX Series Transmitter US Plug Connector	Add	\$ 352.00
Soft Carry Case		\$ 157.00

Advanced iLOC Bluetooth Link: Add to PXL/TX10 Package

RD-TX100 Transmitter w/ iLoc Bluetooth Link add. \$ 351.00

"RD-8100 PDL Series Precision Location System for Duct and Drain Location (Optional)

355' Flexon Drain and Duct Reader 1051 EXR0DIF120	\$	1,839.00
512Hz Standard Sonde, metallic and non-metallic lines 1051CO412-512	\$	419.00
33kHz Super Sonde, non-metallic lines 1051A0337-33R	\$	512.00
Cost for this System:	\$	2,770.00

The following System Accessories and Operator Training Services are included with any Locator Package that you choose.

1. **Comprehensive On-Site Training Class and Manual** **Included**
2. **Tracing Signal Lead, Ground Return Lead & Ground Cables** **Included**
3. **ATS Operator Training Session and "After the Sale" Technical Support** **Included**

The Radiodetection RD-8100. The "World's Only Web-Enabled Location System"
You get all the benefits of the "World's Only Web Enabled Location System" when you equip your RD-8100 Receiver with a RD-TX Series Transmitter:

- **Centros Enabled:** 30 years of software and hardware patents deliver powerful signal filtering which improves accuracy, responsiveness, and repeatability of measurements in environments where most utility location systems fail.
- **Radiodetection's new eCal feature** allows the user to connect the RD-8100 receiver to your computer's Internet connection and validate the original factory calibration and print a validation certificate without having to send the RD-8100 to the service center. You can also update your system by adding the latest factory software updates.
- **New iLOC advanced bluetooth Link:** Saves operator time and effort. iLOC allows remote transmitter control to change locating frequencies, increase or decrease signal output, and enter a standby mode during periods of inactivity to prolong battery life. (Additional charge)
- **At 5 and 10-watt outputs, the "RD-TX Series" is the most flexible line of utility locating transmitters on the market, and with a class leading 10-watt output The RD TX10 is the most powerful portable transmitter available. More power means easier tracing even in the most demanding environments. You'll be able to trace for far greater distances with fewer set-ups so you'll save time and be more accurate.**
- **ATS would be pleased to assist you or perform any of these internet services for you.**
- **8 Standard Induction frequencies result in improved induction mode tracing.**
- **Completely new ergonomic design of the receiver and the transmitter.**
- **Change Batteries in seconds without tools.**
- **TX Series Transmitters have convenient on-board tool storage tray.**
- **This is simply the best and most advanced utility location system you can buy.**

Unmatched Operator Instruction & Technical Support from ATS

ATS not only sells this high performance equipment, but our own field crews have utilized and depended upon Radiodetection technology since 1986. ATS has successfully located underground utilities in a very wide range of challenging applications. Your "Instructional Classroom" and "After-Sale Technical Support" is handled by experienced ATS Field Technicians that use this equipment every day. We know problems can occur at the most inopportune of times. You'll be glad to know that we are as close as our 24-hour hot line or a 60 minute drive from helping your crews work through their questions.

There may be times when your equipment requires servicing, re-calibration or you may just suspect that your system is acting differently than normal. We help our customers to diagnose problems by facilitating repair service in-house to get your system back in service as fast as possible. Radiodetection repair service is generally handled within 7-10 days. In-House Diagnostic Services is just one more way that ATS will help get you back in business as soon as possible. No other Midwest area equipment dealer or catalog house can offer you the same level expertise and technical support that ATS can give to you and your crews.

Proper training ensures that your crews will be more confident, effective and consistently accurate whenever they are called upon to locate a utility line. A confident operator will use the equipment more effectively and more often than one that doesn't receive the proper training. ATS delivers expert training and technical support better than any other dealer. We encourage head to head field comparisons whenever possible.

Why Choose ATS?

1979 - ATS has specialized in Utility Location Services since 1979.

1986 - ATS has exclusively used Radiodetection Equipment since 1986.

1991 - ATS became Radiodetection's Exclusive Factory Authorized Sales and Training Agents to the greater Chicago metropolitan public works market.

2016 - ATS celebrates 37 years of expertise in the Utility and Leak Location Field.

Here are some of the ATS Utility Location Training Classes that we offer.

- *Comprehensive Operator Training Classes*: This class lays a solid foundation of learning for new operators. Students will be taught essential operation procedures for sewer and water location, locating other types of utilities, equipment features and capabilities, field strategy, equipment care and maintenance.
- *Advanced Location Procedures*: This class is for experienced "PRO" operators that would benefit from learning advanced strategies and techniques that will help them get the most out of their equipment in challenging environments and other types of utility location applications.
- *Retraining & Update Training Classrooms*: This class is available for casual or infrequent operators. Refresh and fine tune the skills of those operators that don't get to use the equipment often enough to stay as sharp as they would like to be, yet still need to be effective when the need arises.

April 13, 2010

Add it up - Unlike catalog supply houses or the typical utility product supply house, your Training and After-Sale Technical Support is performed by Experienced ATS Utility Location Experts that use the same equipment everyday in the Field solving location problems in nearly every conceivable environment. That means you get the best possible training and technical support with ATS.

Order Placement and Delivery

Verbal authorization followed by your purchase order is all I need to initiate delivery. Please don't hesitate to contact me if you should have any questions. We appreciate this opportunity to be of continued service to you and the City of Darien.

**Yours truly,
ASSOCIATED TECHNICAL SERVICES LTD.**



**Paul J. Gross
Sales Manager**



Subsurface Solutions

Damage Prevention Experts
www.SubsurfaceSolutions.com

ESTIMATE 18171

DARIEN, CITY OF
Kris Throm
CELL , EMAIL: kthrom@darienil.gov

Valid Till: 05/05/2018
Quoted By: David Shelley
Phone:
Email: david@subsurfacesolutions.com

Q.No. Product Details	Qty	Price	Total
1. RX PXL Radiodetection RD6100PXL Receiver includes: - Auto digital depth - 20+ active frequencies and 4 passive including Power, Radio, CPS and Passive Avoidance Scan - Peak, Null, Peak/Null, & Single Peak mode - Current Direction and more	1	\$3,054.00	\$3,054.00
2. RDTX10 Radiodetection TX-10 transmitter with: - Over 20 active frequencies and 8 Induction frequencies - 10 Watt of power & 90V capacity - LCD backlit display with battery & Volt-Ohm meter - Fault Find capable - cables, ground rod and 3 year warranty	1	\$2,478.00	\$2,478.00
3. 4" Ring Clamp 4" Ring Clamp for SuperCat+	1	\$371.00	\$371.00
4. LOCATOR BAG Soft Carry Bag	1	\$157.00	\$157.00
5. TX BATPACK LIION Transmitter LiIon rechargeable battery pack with AC & DC Charger	1	\$535.00	\$535.00
6. TX LIION BATTERY (no charger) Li-Ion rechargeable battery pack (no charger)	1	\$357.00	\$357.00
7. RX BATPACK-LION Li-Ion rechargeable battery for RD7100/RD6100 series receivers with AC charger	1	\$342.00	\$342.00
8. BATPACK-LION RX Li-Ion rechargeable battery pack (no charger)(RD6100 series only)	1	\$199.00	\$199.00
9. RX-AUTOCHARGER Receiver Ni-Mh battery charger for DC auto plug	1	\$160.00	\$160.00
10. RD7K8KCASE-USA RD7K8K Hard Case	1	\$288.00	\$288.00
11. Freight (estimated)	2	\$75.00	\$150.00

Site Product Details

Qty	Price	Total
Sub Total		\$8,091.00
Adjustments		-\$0.00
Tax		\$0.00
Grand Total		\$8,091.00

Order and Conditions

Trade In: 100% of the value of the old device will be applied to the purchase price of the new device. The trade-in value is determined by the number of minutes on the old device. Radio Shack will not be responsible for the condition of the old device. Price may not include Tax or Shipping. Order Subject to Distribution Schedule. Terms, Conditions, and Policies apply. © 2009 Radio Shack. All Rights Reserved. Terms, Conditions, and Policies apply to all orders placed on this website.

RADIODETECTION

QUOTATION No.: M11198

Please reference the above number in all correspondence

Date: 04/05/2016
Valid Until: 05/05/2016

Customer Address:

Customer:
Ref:
RFQ No.:
Delivery Address:
CITY OF DARIEN

Page 1 of 1

Please Contact Chelsea Campbell @ 207-655-8462 for any questions.

Sales Person: NONE
Phone No:

Payment Term: Credit Card
Shp Via: Ground
Delivery Term: Prepay and Add - Origin

RADIODETECTION DOES NOT PROVIDE TRAINING

SHIPPING ESTIMATE: UPS GROUND TO ZIP CODE 60561.

Part No.	Cust Part No	Description	Qty	Price USD	Disc %	Total USD
10/81PXL		RD8100PXL Locator	1	3,054.00	0.00	3,054.00
10/TX10		TX10 Transmitter	1	2,528.00	0.00	2,528.00
10/TX-CLAMP-4		RD 4" Transmitter Clamp, 4K/7K/8K	1	371.00	0.00	371.00
10/LOCATORBAG		Universal precision loc soft bag	1	157.00	0.00	157.00
10/TXRBATPACKKIT		RD TX Lithium Ion Battery Pack	1	535.00	0.00	535.00
10/RX-MBATPACK-LION-K		RX LI-ION RECHARGEABLE MAINS-KIT	1	342.00	0.00	342.00
10/TX-BATPACK-LION		TX LI-ION RECHARGEABLE PACK	1	357.00	0.00	357.00
10/RX-BATPACK-LION		RX SPARE LI-ION BATTERY -NO CHARGER	1	203.00	0.00	203.00
10/RD7K8KCASE-USA		ENTERPRISE HARD CASE (US VERSION)	1	288.00	0.00	288.00
Sub Total				7,835.00		7,835.00
				SHIPPING & FUEL SURCHARGES		60.00
* Total				USD		7,895.00

- Price does not include Tax or Shipping
- Order Subject to Radiodetection Terms & Conditions
- Order Cancellation Fee or Return subject to 25% Restocking/Cancellation Fee
- Terms: N30 with approved credit or Visa, Mastercard, American Express, Wire Transfer.

***** Important Note: If this is for Export, we must know the complete name and address of the end user so the correct information may be provided for export compliance.**

Approved By:	Print Name:	Payment Type:
		PO <input type="checkbox"/> VISA M/C <input type="checkbox"/> Cash/Check <input type="checkbox"/>

SPX Corporation
Radiodetection
28 Tower Rd
Raymond
Maine 04071
United States of America

Telephone +1 207 655 8525
Fax +1 207 655 8535
www www.radiodetection.com
Federal ID 38-1016240

4/13/2016 17

AGENDA MEMO
Municipal Services Committee
April 25, 2016

ISSUE STATEMENT

A **resolution** authorizing the Mayor to accept a proposal from JX Enterprises, Inc. for the purchase of one new 2017 Peterbilt Model 348 with dump body and snow plow/deicing equipment package in the amount of \$174,910.

BACKGROUND/HISTORY

The new truck is to be utilized primarily for material hauling, snow plowing, and de-icing operations for the street division. The truck would be replacing Unit 105, which is a 2002 GMC 8500 Dump Truck with 53,000. The vehicle has ongoing mechanical and electrical problems, including severe exterior rusting. Unit 105 was budgeted for replacement and the vehicle rating report is 75.70 and is attached and labeled as Attachment A. Please recall the Vehicle Replacement Policy calls out for vehicles to be replaced at a rating of 75 or above.

The proposed cab and chassis is a 2017 Peterbilt Model 348 with a Henderson dump body, hydraulic equipment, snow plow and deicing equipment. The vehicle would be purchased through the Lake County Department of Transportation Joint Purchase Contract No 15015 (attached and labeled as Attachment B – 5 pages) with the awarded vendor, JX Enterprises, Inc. in the amount of \$174,910 and as per the attached specs labeled as Attachment C (13 pages).

The proposed expenditure would be expended from the following line account:

ACCOUNT NUMBER	ACCOUNT DESCRIPTION	FY 16-17 BUDGET	PROPOSED EXPENDITURE	PROPOSED BALANCE
01-30-4815	CAPITAL PURCHASES TRUCK REPL UNIT 105	\$ 185,000	\$ 174,910	\$10,090
01-30-4815	CAPITAL PURCHASES TRUCK DECALS	\$ 915	\$ 915	\$ 9,175

STAFF RECOMMENDATION

Staff recommends the approval of the resolution authorizing the Mayor to accept a proposal from JX Enterprises, Inc. for the purchase of one new 2017 Peterbilt Model 348 with dump body and snow plow/deicing equipment package in the amount of \$174,910.

2017 Peterbilt Truck
April 25, 2016
Page 2

ALTERNATE DECISION

As recommended by the Committee.

DECISION MODE

This item will be placed on the May 2, 2016 City Council agenda for formal consideration.

CRITERIA FOR REPLACING CITY VEHICLES AND EQUIPMENT				
UNIT NO	105	DEPARTMENT	Street	DATE
MODEL YEAR	2002	MODEL	8500	10-24-15
CURRENT MILEAGE	50,998	CURRENT HOURS		
			MAXIMUM POINTS	VEHICLE SCORE
AGE				
	Department	Street		
	Life Expectancy	12		
	Age as of Report Date	13		
	AGE: Meets Requirements	Yes	20	20
USAGE				
	MILES	50,998		
	HOURS			
	ATTACHMENT C OF THE VEHICLE REPLACEMENT POLICY			
	USAGE: Meets Requirements		20	10.20
TYPE OF SERVICE				
	1-LIGHT DUTY			
	15-CRITICAL DUTY			
	SERVICE: Meets Requirements		15	9
RELIABILITY				
	RELIABILITY: Frequency or Visits for Service			
	RELIABILITY: Meets Requirements		15	14
MAINTENANCE AND REPAIR COSTS				
	REPAIRS: Cost per Mile/Hours Exceeds Vehicle in Class			
	ORIGINAL PURCHASE PRICE	95,000.00		
	LIFE TO DATE REPAIR COST	13,431.59		
	PERCENTAGE OF REPAIRS TO PURCHASE PRICE	14.14%		

UNIT NO	105	DEPARTMENT	Street	DATE	
MODEL YEAR	2002	MODEL	8500		10-24-15
CURRENT MILEAGE	50,998	CURRENT HOURS			
			MAXIMUM POINTS		VEHICLE SCORE
PERCENTAGES OF REPAIR POINTS	POINTS				
1 THROUGH 20	2				
21 THROUGH 40	4				
41 THROUGH 60	6				
61 THROUGH 80	8				
81 THROUGH 100	10				
	REPAIRS: Meets Requirements		10		2.5
CONDITION					
	CONDITION OF ENGINE COMPONENTS (MAJOR REPAIRS NEEDED OR ANTICIPATED), BODY (BODY SHEET METAL RUSTED, STRUCTURAL COMPONENTS)				
	CONDITION: Meets Requirements		15		1.5
TECHNOLOGICAL ADVANCEMENTS	FUEL EMISSIONS, SAFETY FEATURES, ERGONOMICS		5		5
TOTAL POINTS			100		75.70

CITY OF DARIEN
 Repair Transaction Cost Detail

Equipment#	Repair Order#	Date	Meter(1)	Shop Loc/ Rep Class	Rep Reason/ Rep Site			
105	0000027552	11/27/07	15581	/01	08/01			
	<u>Group-System</u>			<u>Mech/Vendor</u>	<u>Work Acc</u>	<u>Part(\$)</u>	<u>Labor(\$)</u>	<u>Hours</u>
	01-PMB - PREV. MAINT.			001		0.00	28.00	1.00
	01-PMC - PREV. MAINT.			001		89.82	28.00	1.00
105	0000027599	01/04/08	16161	/01	08/01			
	08-36 - MARS & STROBE			002		100.00	15.00	1.00
105	0000027706	02/04/08	17350	/02	01/01			
	08-32 - CRANKING SYS			001		31.40	112.00	4.00
105	0000027739	03/04/08	18168	/01	08/01			
	01-PMA - PREV. MAINT.			002		44.80	30.00	2.00
105	0000027800	04/10/08	17956	/01	08/01			
	01-PME - PREV. MAINT.			002		30.00	7.50	0.50
105	0000027834	04/28/08	18250	/01	08/01			
	08-36 - MARS & STROBE			001		129.66	28.00	1.00
105	0000028101	10/27/08	19658	/01	08/01			
	01-PME - PREV. MAINT.			002		30.00	7.50	0.50
105	0000028127	11/12/08	20140	/01	08/01			
	08-39 - HORN & SIREN			001		54.36	28.00	1.00
105	0000028178	12/15/08	20730	/01	08/01			
	07-44 - FUEL SYS			002		27.44	15.00	1.00
105	0000028201	01/05/09	21900	/01	08/01			
	01-PMA - PREV. MAINT.			001		87.75	84.00	3.00
105	0000028218	01/19/09	23030	/01	08/01			
	09-57 - HYDRAULIC SYS			001		100.00	84.00	3.00
105	0000028267	02/25/09	23670	/01	08/01			
	04-12 - AXEL REAR			001		736.67	28.00	1.00
105	0000028298	03/30/09	23782	/01	08/01			
	02-17 - TIRES,TUBES,ETC			002		280.11	15.00	1.00
105	0000028332	04/28/09	23729	/01	08/01			
	01-PME - PREV. MAINT.			002		30.00	7.50	0.50
105	0000028387	06/02/09	24421	/01	08/01			
	04-18 - SUSPENSION			002		1,166.64	60.00	4.00
105	0000028416	06/30/09	25423	/01	08/01			
	04-15 - STEERING			002		100.00	15.00	1.00
105	0000028436	07/06/09	25425	/01	08/01			
	01-PMA - PREV. MAINT.			002		43.99	30.00	2.00
105	0000028507	09/01/09	26440	/01	08/01			
	05-27 - XMISSION AUTO			001		516.93	112.00	4.00
105	0000028557	10/13/09	26579	/01	08/01			
	01-PME - PREV. MAINT.			002		30.00	7.50	0.50
105	0000028585	10/27/09	27350	01/02	01/01			
	07-45 - POWER PLANT			001		492.57	84.00	3.00
105	0000028684	01/14/10	29430	01/01	08/01			
	01-PMA - PREV. MAINT.			001		43.38	70.00	2.50
105	0000028685	01/15/10	29430	01/02	01/01			
	07-43 - EXHAUST SYS			001		795.63	42.00	1.50

CITY OF DARIEN
 Repair Transaction Cost Detail

Equipment#	Repair Order#	Date	Mater(1)	Shop Loc/ Rep Class	Rep Reason/ Rep Site			
105	0000028700	01/27/10	29850	01/02	01/01			
	<u>Group-System</u>			<u>Mech/Vendor</u>	<u>Work Acc</u>	<u>Part(\$)</u>	<u>Labor(\$)</u>	<u>Hours</u>
	09-84 - AUGERS & V-BOXS			001		59.40	58.00	2.00
105	0000028730	02/12/10	30229	01/03	01/01			
	08-34 - LIGHTING SYS			001		51.25	84.00	3.00
105	0000028753	03/09/10	30810	01/01	08/01			
	01-PMC - PREV. MAINT.			001		74.85	28.00	1.00
	01-PMB - PREV. MAINT.			001		525.00	224.00	8.00
105	0000028809	04/21/10	30797	01/01	08/01			
	01-PME - PREV. MAINT.			001		0.00	0.00	0.00
105	0000029022	10/04/10	32625	01/01	08/01			
	01-PME - PREV. MAINT.					0.00	0.00	0.00
105	0000029118	01/14/11	34156	01/01	08/01			
	01-PMA - PREV. MAINT.			002		56.91	30.00	2.00
	07-41 - AIR INTAKE SYS			002		44.14	3.75	0.25
105	0000029179	03/09/11	35710	01/02	01/01			
	09-84 - AUGERS & V-BOXS			001		100.00	112.00	4.00
105	0000029246	04/29/11	35942	01/01	08/03			
	01-PME - PREV. MAINT.					0.00	30.00	0.00
105	0000029433	10/03/11	36936	01/02	01/01			
	08-35 - BATTERY			002		267.00	15.00	1.00
105	0000029457	10/25/11	37104	01/02	01/01			
	07-44 - FUEL SYS			002		20.10	7.50	0.50
105	0000029462	10/26/11	36899	01/01	08/03			
	01-PME - PREV. MAINT.					0.00	30.00	0.00
105	0000029566	01/12/12	37904	01/02	01/01			
	06-36 - MARS & STROBE			002		70.00	3.75	0.25
105	0000029584	01/24/12	38237	01/02	01/01			
	08-39 - HORN & SIREN			002		50.65	30.00	2.00
105	0000029838	02/28/12	38599	01/01	08/01			
	01-PMA - PREV. MAINT.			002		45.18	33.75	2.25
	07-41 - AIR INTAKE SYS			002		44.37	3.75	0.25
105	0000029721	04/04/12	38936	01/01	08/03			
	01-PME - PREV. MAINT.					0.00	30.00	0.00
105	0000029725	05/02/12	38879	01/03	01/01			
	03-06 - DOORS			002		17.14	30.00	2.00
105	0000029791	06/21/12	38950	01/03	01/01			
	03-06 - DOORS			002		25.00	7.50	0.50
105	0000029947	10/30/12	39512	01/01	08/03			
	01-PME - PREV. MAINT.					0.00	30.00	0.00
105	0000030054	02/12/13	40341	01/03	01/01			
	09-63 - HOSES & FITTING			002		215.12	37.50	2.50
105	0000030077	03/11/13	41184	01/03	01/01			
	06-36 - MARS & STROBE			002		19.50	11.25	0.75
	04-13 - BRAKES			002		9.54	15.00	1.00
105	0000030144	04/29/13	41216	01/01	08/03			

CITY OF DARIEN
 Repair Transaction Cost Detail

Equipment#	Repair Order#	Date	Meter(1)	Shop Loc/ Rep Class	Rep Reason/ Rep Site			
	01-PME - PREV. MAINT.					0.00	30.00	0.00
105	0000030181	05/21/13	41538	01/03	01/01			
	<u>Group System</u>			<u>Mech/Vendor</u>	<u>Work Acc</u>	<u>Part(\$)</u>	<u>Labor(\$)</u>	<u>Hours</u>
	04-16 - SUSPENSION			002		9.64	7.50	0.50
105	0000030332	10/28/13	42910	01/03	01/01			
	06-36 - MARS & STROBE			002		14.77	3.75	0.25
105	0000030341	10/31/13	42684	01/01	08/03			
	01-PME - PREV. MAINT.					0.00	30.00	0.00
105	0000030378	12/20/13	43627	01/01	08/01			
	01-PMA - PREV. MAINT.			002		68.74	56.25	3.75
	07-41 - AIR INTAKE SYS			002		43.13	0.00	0.00
105	0000030404	01/08/14	44850	01/03	01/01			
	04-16 - SUSPENSION			002		1,037.15	120.00	8.00
105	0000030430	02/26/14	46899	01/03	01/01			
	09-61 - LIFT CYLINDER			002		437.98	7.50	0.50
105	0000030437	02/28/14	46899	01/02	01/01			
	06-32 - CRANKING SYS			002		298.04	105.00	7.00
105	0000030459	04/03/14	47399	01/03	01/01			
	04-15 - STEERING			002		367.57	22.50	1.50
105	0000030482	04/29/14	47455	01/03	01/01			
	05-27 - XMISSION AUTO			002		564.47	45.00	3.00
	07-44 - FUEL SYS			002		122.49	90.00	6.00
105	0000030493	04/30/14	47317	01/01	08/03			
	01-PME - PREV. MAINT.					0.00	30.00	0.00
105	0000030526	05/21/14	47471	01/03	01/01			
	03-03 - SHEET METAL			002		24.56	3.75	0.25
	04-13 - BRAKES			002		239.96	45.00	3.00
105	0000030563	06/25/14	47568	01/03	01/01			
	03-03 - SHEET METAL			002		16.30	7.50	0.50
105	0000030571	06/30/14	47277	01/03	01/01			
	04-15 - STEERING			002		171.61	22.50	1.50
	06-36 - MARS & STROBE			002		40.00	3.75	0.25
105	0000030573	07/02/14	47759	01/03	01/01			
	06-31 - CHARGING SYS			002		227.49	30.00	2.00
105	0000030583	07/11/14	48005	01/03	01/01			
	04-15 - STEERING			002		306.77	30.00	2.00
105	0000030678	10/06/14	48270	01/03	01/01			
	06-39 - HORN & SIREN			002		96.85	7.50	0.50
105	0000030679	10/08/14	48280	01/01	08/01			
	01-PMA - PREV. MAINT.			002		80.30	52.50	3.50
	07-41 - AIR INTAKE SYS			002		44.37	3.75	0.25
105	0000030718	10/28/14	48270	01/01	08/03			
	01-PME - PREV. MAINT.					0.00	30.00	0.00
105	0000030781	01/23/15	49728	01/03	01/01			
	06-36 - MARS & STROBE			002		156.81	15.00	1.00
105	0000030839	04/14/15	50835	01/03	01/01			

CITY OF DARIEN
 Repair Transaction Cost Detail

Equipment#	Repair Order#	Date	Meter(1)	Shop Loc/ Rep Class	Rep Reason/ Rep Site			
	04-16 - SUSPENSION			002		1,152.60	75.00	5.00
	06-34 - LIGHTING SYS			002		28.84	22.50	1.50
105	0000030849	04/23/15	50908	01/03	01/01			
	<u>Group-System</u>			<u>Mech/Vendor</u>	<u>Work Acc</u>	<u>Part(\$)</u>	<u>Labor(\$)</u>	<u>Hours</u>
	03-07 - INTERIOR			002		161.94	7.50	0.50
105	0000030857	04/27/15	50987	01/03	01/01			
	03-07 - INTERIOR			002		125.96	60.00	4.00
105	0000030862	04/29/15	50590	01/01	08/03			
	01-PME - PREV. MAINT.					0.00	30.00	0.00
105	0000030908	06/03/15	50998	01/03	01/01			
	07-43 - EXHAUST SYS			002		1,230.73	75.00	5.00
105	0000030996	11/05/15	52662	01/03	01/01			
	03-07 - INTERIOR			002		87.55	60.00	4.00
105	0000031013	10/16/15	51719	01/01	08/03			
	01-PME - PREV. MAINT.					0.00	30.00	0.00
Grand Total						<u>15,206.42</u>	<u>3,582.50</u>	<u>162.50</u>



535 E. South Frontage Rd / Bolingbrook, IL / 60440

Date: 4-11-2016

To: Village of Darien
Kris Throm
1041 Frontage Rd
Darien, IL. 60561

REF: Lake County DOT Joint Purchase # 15015

Dear Kris,

We are pleased to quote the following Peterbilt Model 348 Single AXLE per the attached summary which utilizes the Lake County Joint Purchase Contract number 15015 pricing with the specification discussed to accommodate the Village of Darien's requirements .

2017 Peterbilt Model 348

Same as 2016 Tandem Specifications w/ extended cab
Henderson Equipment / 10' dump with Options included.

Heated Windshield

5 Year / 150,000 mile engine warranty

Title and Plates

All As Per Attached

Lake County Joint Purchase agreement 15015

Total Sale **\$ 174,910.00**

Municipal FET and Sales Tax Exempt // Final Payment Due Upon Delivery

Rick Michalowski | Vocational Account Manager
JX Enterprises, Inc.
Cell 708-207-2354 | Fax 708-460-8991
rmichalowski@jxe.com
www.JXE.com

Contract Award
RFP #080114

FORM D



Formal Offering of Proposal
(To be completed Only by Proposer)

SNOW AND ICE HANDLING EQUIPMENT WITH RELATED ACCESSORIES, SERVICES, AND SUPPLIES

In compliance with the Request for Proposal (RFP) for SNOW AND ICE HANDLING EQUIPMENT WITH RELATED ACCESSORIES, SERVICES, AND SUPPLIES the undersigned warrants that I/we have examined this RFP and, being familiar with all of the instructions, terms and conditions, general specifications, expectations, technical specifications, service expectations and any special terms, do hereby propose, fully commit and agree to furnish the defined equipment/products and related services in full compliance with all terms, conditions of this RFP, any applicable amendments of this RFP, and all Proposer's Response documentation. Proposer further understands they accept the full responsibility as the sole source of responsibility of the proposed response herein and that the performance of any sub-contractors employed by the Proposer in fulfillment of this proposal is the sole responsibility of the Proposer.

Company Name: HENDERSON PRODUCTS INC Date: AUG 16 2006

Company Address: 1085 SOUTH 3RD STREET PO BOX 40

City: MANCHESTER State: IA Zip: 52057

Contact Person: GLENN BECK Title: VP SALES & MARKETING

Authorized Signature (ink only): [Signature] GLENN BECK
(Name printed or typed)

10/21/14



Contract Acceptance and Award

(To be completed only by NJPA)

NJPA 000114 SNOW AND ICE HANDLING EQUIPMENT WITH RELATED ACCESSORIES, SERVICES, AND SUPPLIES

HENDERSON PRODUCTS, INC.
Proposer's full legal name

Your proposal is hereby accepted and awarded. As an awarded Proposer, you are now bound to provide the defined products/equipment and services contained in your proposal offering according to all terms, conditions, and pricing set forth in this RFP, any amendments to this RFP, your Response, and any exceptions accepted or rejected by NJPA on Form C.

The effective start date of the Contract will be October 21, 20 14 and continue for four years from the board award date. This contract has the option of a one year renewal option at the discretion of NJPA.

National Joint Powers Alliance (NJPA)

NJPA Authorized signature:

NJPA Executive Director

Dr. Chad Corvette

(Name printed or typed)

Awarded this

21st day of October, 20 14

NJPA Contract Number 000114-HPI

NJPA Authorized signature:

NJPA Board Member

Scott Veronen

(Name printed or typed)

Excluded this

21st day of October, 20 14

NJPA Contract Number 000114-HPI

Proposer hereby accepts contract award including all accepted exceptions and NJPA clarifications identified on FORM C.

Vendor Name Henderson Products Inc.

Vendor Authorized signature:

Glenn Beck

(Name printed or typed)

Title VP Sales & Marketing

Executed this

23rd day of October, 20 14

NJPA Contract Number 000114-HPI

NO HIDDEN CHARGES

**NJPA AWARDED
CONTRACT**

Henderson®

ALL-INCLUSIVE PACKAGES:

**PRICING INCLUDES EQUIPMENT, HYDRAULICS, INSTALLATION,
AND DELIVERY!**



NO LIABILITY • NO COST • NO OBLIGATION
JOIN FREE

**REGISTER TODAY
TO PURCHASE OF THE CONTRACT!**

<http://www.njpacoop.org/national-cooperative-contract-solutions/join-njpa/>

CONTRACT 080114-HPI

NJPA AWARDED CONTRACT

CONTRACT NUMBER

080114-HPI

PRICING INCLUDES EQUIPMENT, HYDRAULICS, INSTALLATION AND DELIVERY!

PRODUCTS AVAILABLE

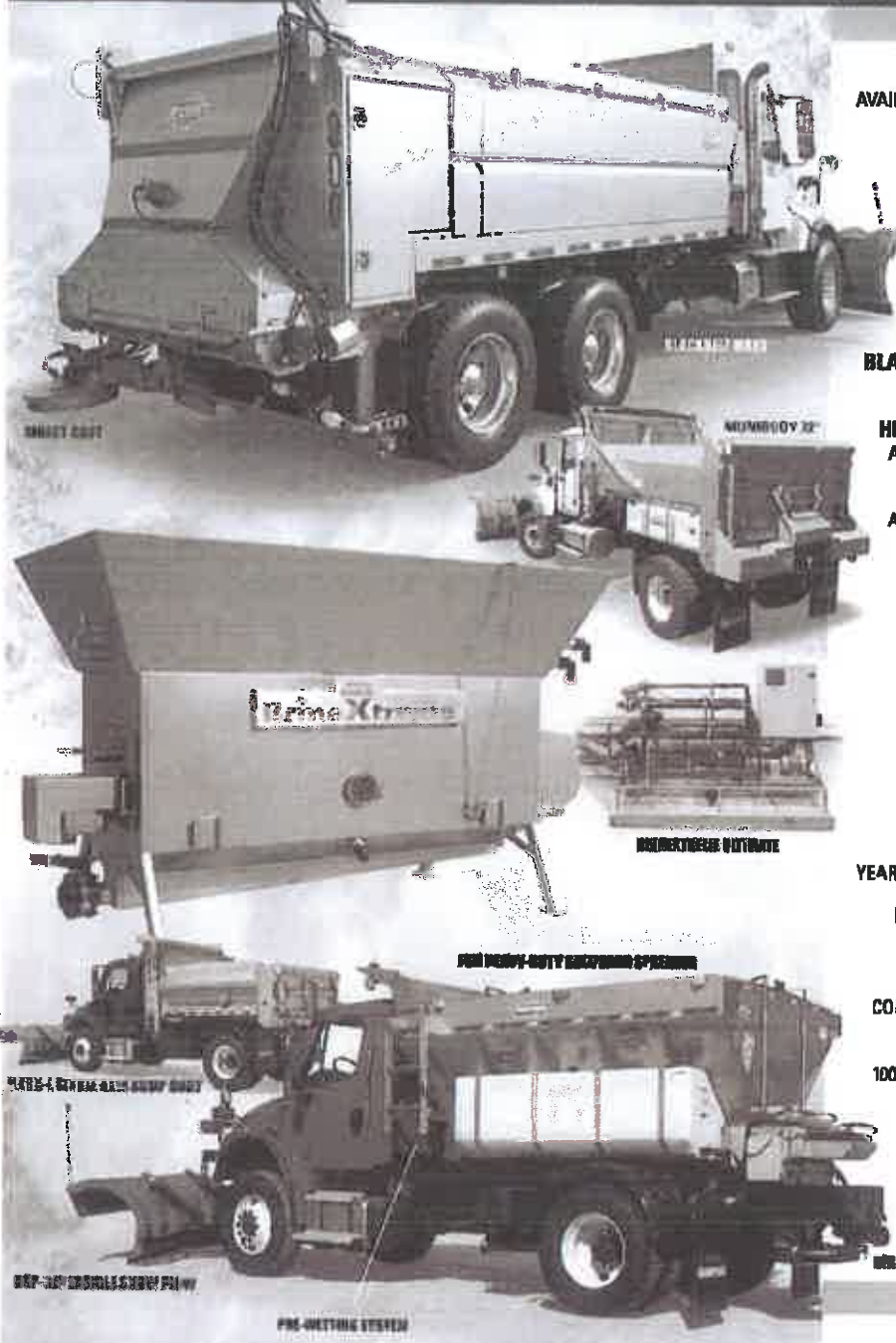

RSP - REVERSIBLE SNOW PLOW
AVAILABLE IN POLY, MILD STEEL OR STAINLESS STEEL MOLDBOARD

MARK-E SINGLE AXLE DUMP BODY
AVAILABLE IN MILD OR STAINLESS STEEL

MARK-E TANDUM AXLE DUMP BODY
AVAILABLE IN MILD OR STAINLESS STEEL

MUNIBODY (22° or 35° SLOPED SIDES)
COMBINATION DUMP BODY & SPREADER
AVAILABLE IN MILD OR STAINLESS STEEL

BLACKBELT MAXX ALL-SEASON MULTI-PURPOSE BODY
AN ADVANCED COMBINATION BODY

HENDERSON WING SYSTEMS (CABLE OR HYDRAULIC)
AVAILABLE WITH MILD OR STAINLESS STEEL MOLDBOARD

UNDERBODY SCRAPER (FIXED OR REVERSING)
AVAILABLE WITH MILD OR STAINLESS STEEL MOLDBOARD

FSH - HEAVY-DUTY SALT/SAND SPREADER
AVAILABLE IN MILD OR STAINLESS STEEL

TGS - TAILGATE SPREADER
LOW MAINTENANCE SPREADER
AVAILABLE IN MILD OR STAINLESS STEEL

PRE-WETTING SYSTEMS
HYDRAULIC OR ELECTRIC CONTROLS

FIRST RESPONSE SYSTEM
4-IN-1 ADVANCED ANTI-ICING & DEICING SYSTEM

LAS - LIQUID APPLICATION SYSTEM
YEAR ROUND USE, EASILY SLIPS INSIDE EXISTING DUMP BODIES

DIRECT CAST - PRECISION PLACEMENT SPINNER
ON-THE-GO DIRECTIONAL CONTROL PRECISION CAST

BRINEXTREME PRO
CONTINUOUS BRINE PRODUCTION SYSTEM-UP TO 6,000 GPH

BRINEXTREME ULTIMATE
100% AUTOMATION, REPEATABILITY & SELF CLEANING WITH
CONTINUOUS BRINE PRODUCTION UP TO 9,600 GPH

BRINEXTREME MOBILE UNIT
MOBILIZE! 100% AUTOMATION, REPEATABILITY
& SELF CLEANING WITH CONTINUOUS
BRINE PRODUCTION UP TO 9,600 GPH

Available in:
201 STAINLESS STEEL
304 STAINLESS STEEL
409 STAINLESS STEEL
MILD STEEL GRADE 50
AR400
POLYMER MOLDBOARD

TO ORDER, CONTACT:



HENDERSON PRODUCTS, INC.
JANET TOBIN | CONTRACT ADMINISTRATOR
(563) 927-7267
1085 South Third Street, Manchester, IA 52057
jtobin@hendersonproducts.com
www.hendersonproducts.com

PETERBILT

JX Peterbilt - Wadsworth P125
42400 Old Hwy 41

City of Darien
1041 S Frontage Rd

Wadsworth, Illinois United States 60083
Phone: (847) 395-7222
Fax: (847) 395-7240
Email:

Darien, Illinois United States 60561
Phone:
Fax:
Contact Email:
Prepared for: Dan Gombac

Vehicle Summary

	Unit		Chassis	
Model:		Model 348	Fr Axle Load (lbs):	20000
Type:		Full Truck	Rr Axle Load (lbs)	23000
Description:		Single Axle	G.C.W. (lbs):	43000
	Application		Road Conditions:	
Intended Serv.:		Snowplow	Class A (Highway)	100
Commodity:		Other Commodity	Class B (Hwy/Mtn)	0
	Body		Class C (Off-Hwy)	0
Type:		End Dump	Class D (Off-Road)	0
Length (ft):		10	Maximum Grade:	6
Height (ft):		11.0	Wheelbase (in):	164
Max Laden Weight (lbs):		3200	Overhang (in):	45.8
	Trailer		Fr Axle to BOC (in):	69.8
No. of Trailer Axles:		0	Cab to Axle (in):	94.2
Type:			Cab to EOF (in):	140.0
Length (ft):		0	Overall Comb. Length	275
Height (ft):		0.0	(in):	
Kingpin Inset (in):		0		
Corner Radius (in):		0	Special Req.	
	Restrictions		United States Registry	
Length (ft):		40		
Width (in):		102		
Height (ft):		13.5		

Approved by: _____

Date: _____

Note: All sales are F.O.B. designated plant of manufacture.

PacLease can help control costs and eliminate the challenges of owning, operating and maintaining your truck fleet.

- Improve Operations - Preserve Capital for Growth - Stay Focused on Your Business

Contact PacLease for a quote today, or visit our website @ www.paclease.com.

Unpublished options may require review/approval.
Dimensional and performance data for unpublished options may vary from that displayed in PROSPECTOR.

Printed: 3/22/2016 10:02:21 AM
Effective Date: Jan 1, 2016
Prepared by: ID: rmich

Incomplete

Model Number: Model 348
Quote/DTPO/CO: Q76812223
Version Number: 32.11

JX Peterbilt - Wadsworth P125
42400 Old Hwy 41

City of Darien
1041 S Frontage Rd

Wadsworth, Illinois United States 60083
Phone: (847) 395-7222
Fax: (847) 395-7240
Email:

Darien, Illinois United States 60561
Phone:
Fax:
Contact Email:
Prepared for: Dan Gombas

	Description
Base Model	Model 348
	Other Commodity
	Snowplow Truck which is configured for mounting a snowplow to the front. May also have dump or other body.
	End Dump
	United States Registry
Configuration	Not Applicable Secondary Manufacturer
Frame & Equipment	10-3/4In Steel Rails To 354In 10.75x3.5x.375 Dimension, 2,136,000 RBM; Yield Strength: 120,000 psi. Section Modulus: 17.8 cubic inches. Weight: 1.74 lbs/inch pair
	Custom Wheelbase or Overhang Engineering approval may be required.
	Three-Piece Crossmembers
	FEPTO Provision 27.8in Bumper Extension Includes Crankshaft Adapter Plate and Stationary Grille. Requires FEPTO Bumper.
	ECF Square without Xmb For use with body builder installed crossmember.
	Omit Rear Mudflaps and Hangers
Front Axle & Equipment	Dana Spicer D2000F 20,000 lb, 3.5in Drop Factory front axle alignment to improve handling & reduce tire wear. Zerk fittings on tie rod ends, king pins, & draglink ball joints for ease of maintenance & help extend service life of components. Cognis EMGARD® FE 75W-90 synthetic axle lube provides over 1% fuel economy improvement. Reduces wear & extends maintenance intervals, resulting in increased uptime. Provides improved fluid flow to protect components in extreme cold conditions & withstand the stress from high temperatures, extending component life.
	Taper Leaf Springs, Shocks 20,000 lb Standard with Heavy Resistance Shocks.
	Power Steering Sheppard HD94 Dual For use with 16,000 to 20,000 lb. axle ratings.
	Power Steering Reservoir Frame Mounted w/Cooler
	PHP10 Iron LMS Hubs-Air Disc
	Air Disc Front Brakes Complies with reduced stopping distance regulations.
	Dust Shields, CAM And Air Disc Brakes, Front Axle
	Gusseted Cam Brackets, Steer Axle

Rear Axle & Equipment

Dana Spicer S23-170 23,000 lb

Laser factory axle alignment to improve handling & reduce tire wear.

Magnetic rear axle oil drain plug captures & holds any metal fragments in drive axle lube to extend service life. Parking brakes on all drive axles for optimal performance. Cognis EMGARD® FE 75W-90 synthetic axle lube provides over 1% fuel economy improvement. Reduces wear & extends maintenance intervals, resulting in increased uptime. Provides improved fluid flow to protect components in extreme cold conditions & withstand the stress from high temperatures, extending component life.

PHP10 Iron LMS Hubs

11-1/4" bolt circle. Includes a supplier extended coverage up to 3 years / 350,000 miles for bearings & seals.

Standard Stroke Parking Brakes

Drive Axle(s)

Dust Shields For Cam Brakes, Drive Axle(s)

Diff Lock Rear-Rear Or Single Drive Axle

(Air Rocker Switch occupies the space of one gauge)

Separate Dash Controls, Cont Trac Full Lock

Dana Spicer or Meritor - Tandem or TriDrive Axles (Air Rocker Switch occupies the space of two gauges for tandem axle and three gauges for tri-drive axle)

Gusseted Cam Brackets, Drive Axle(s)

SBM Valve

Full trucks require a spring brake modulation (SBM) system for emergency braking application. This system requires an SBM valve and a relay valve with spring brakes on the rear axles. The SBM valve allows the front valve to operate the rear axle spring brakes if a failure exists in the rear air system.

Stability System Not Selected or Not Available

Anti-Lock Braking System (ABS) 4S4M

ABS-6. Includes air braking system.

Synthetic Axle Lubricant All Axles

Peterbilt heavy duty models include Fuel Efficient Cognis EMGARD FE75W-90 which provides customers performance advantages over current synthetic lubricants with reduced gear wear and extended maintenance intervals, resulting in increased uptime. In addition, the lubricant provides improved fluid flow to protect gears in extreme cold conditions and withstand the stress from high temperatures, extending component life.

Single Drive Axle (Model 340)

Bendix Air Cam Rear Drum Brakes 16.5x7

Inc automatic slack adjusters & cabboard mounted brake drums.

Ratio 5.63 Rear Axle

Peterbilt Air Trac 23,000 lb Light Weight

Dash Mid Dump Switch With Indicator Light

For suspension

Engine & Equipment

PACCAR PX-9 330@2000 GOV@2200 1000@1400

(2013 Emissions) Includes alum flywheel housing, cruise control, and J1939 provisions (provides an interface point for the Electronic Service Analysis-ESA and other PACCAR approved diagnostic tools). Chevron Delo LE SAE 10W30 engine oil is specially formulated for new low emissions engines. Magnetic engine oil drain plug captures and holds any metal fragments in engine oil to extend service life.

N21320 N205 120..Standard Maximum Speed Limit [LSL]

N21330 N207 0...Expiration Distance

N21340 P005 120..Hard Maximum Speed Limit

N21350 P001 64...Maximum Accelerator Pedal Vehicle Speed

N21360 P110 0...Accelerator Lower Droop

N21370 P059 64...Maximum Cruise Speed

N21380 P111 0...Cruise Control Lower Droop

N21400 N203 252..Reserve Speed Function Reset Distance

N21410 N202 0...Maximum Cycle Distance

N21420 N206 10...Maximum Active Distance

N21430 N201 0...Reserve Speed Limit Offset
 N21440 P015 No...Engine Protection Shutdown
 N21450 P026 No...Gear Down Protection
 N21460 P046 1400.Max PTO Speed
 N21470 P062 No...Cruise Control Auto Resume
 N21480 P068 No...Auto Engine Brake In Cruise
 N21500 N209 0...Expiration Distance
 N21510 P520 Yes..Enable Idle Shutdown Park Brake Set
 N21520 P030 5...Timer Setting
 N21530 P233 Yes..Enable Impending Shutdown Warning
 N21540 P234 60...Timer For Impending Shutdown Warning
 N21550 P516 35...Engine Load Threshold
 N21570 P031 No...Idle Shutdown Manual Override
 N21590 P230 Yes..Enable Hot Ambient Automatic Override
 N21610 P172 40...Low Ambient Temperature Threshold
 N21620 P173 80...Intermediate Ambient Temperature Threshold
 N21630 P171 80...High Ambient Temperature Threshold

Engine Idle Shutdown Timer Disabled

Enable EIST Ambient Temp Override

Eff EIST NA Expiration Miles

Effective VSL Setting NA

Belly Pan

CARB Engine Idling Compliance

PACCAR PX-7, PX-9 and MX, Cummins ISL, ISM and ISX diesel engines will include the required factory installed serialized sticker on the drivers door to identify them as meeting the NOx idling standard.

PACCAR 160 Amp Alternator, Brushed

Immersion Type Block Heater 110-120V

Standard location is center left hand under cab and includes a weather-proof cover that protects the receptacle. This pre-heater keeps the coolant in the engine block from freezing when the engine is not running.

PACCAR 12V Starter

3 PACCAR Premium 12V Dual Purpose Batt 2100 CCA

Threaded stud type terminal. Stranded copper battery cables are double aught (00) or larger to reduce resistance.

Battery Jumper Terminal Mounted Under Hood

LH Frame Rail. Not available with PX-7 engines.

2-Speed Fan Clutch For Frequent Start/Stops

18.7 CFM Air Compressor

Furnished on engine. Teflon lined stainless steel braided compressor discharge line.

Spin-On Fuel Filter/Water Separator, 12V Heated

Frame Mounted. In addition to the fuel filter supplied with the engine. Includes fuel water separator on Models 330, 337, and 348.

High Efficiency Cooling System

Cooling module is a combination of steel and aluminum components, with aluminum connections to maximize performance and cooling capability. Silicone radiator & heater hoses enhance value, durability, & reliability. Constant tension band clamps reduce leaks. ClimaTech extended life coolant extends maintenance intervals which reduces maintenance costs. Anti-freeze effective to -30 degrees F helps protect the engine. Low coolant level sensor warns of low coolant condition to prevent engine damage. Radiator Size by Model: 587: 1330 sq in, 579/367 FEPTO 1325 sq in, 587/365/367: 1440 sq in, 384/386: 1301 sq in, 365 FEPTO: 1184 sq in, 369/367 HH: 1669 sq in, 348: 1000 sq in, 320: 1242 sq in.

Radial Seal, Dry Type Air Cleaner, Frontal

Air Intake. Molded rubber air intake connections with lined stainless steel clamps seal to prevent contaminants in air intake.

Exhaust Single RH Side Of Cab

DPF/SCR RH under cab. Includes cab entry RH under cab and full round stainless steel exhaust guard.

Curved Tip Standpipe(s)

18In Ht, 6In Dia Chrome, Clear Coat Standpipe(s)

Transmission & Equipment

Allison 3000 RDS-P Transmission, Gen 5
Rugged Duty Series. Includes Rear Transmission Support, TranSynd Automatic Transmission Fluid, and Water Oil Heat Exchange. Also includes features that monitor the transmission fluid, filter and clutch condition. Will display percent life remaining for the transmission fluid, filter and clutches on the shift selector. This information may be displayed using the Mode and Up and Down buttons. A wrench icon will also be included to indicate when the transmission fluid, filter or clutches need servicing. (Suited for vehicles operating on/off highway and/or requiring PTO operation) Forward Ratios: 1st-3.49, 2nd-1.86, 3rd-1.41, 4th-1.00, 5th-0.75, 6th-0.65 / Reverse Ratio: DR-(5.03)

1710 HD Driveline, 1 Midship Bearing

Programming Allison Snowplow

Primary shift 1 and shift 2, secondary shift schedule fixed 2 (no LBSS)

Allison FuelSense Not Desired

Allison 9-Speed Configuration, Close Ratio Gears

3000 Series Transmissions

Seat Mounted Lever Shifter

Air & Trailer Equipment

Bendix AD-IS Air Dryer with Heater

An integrated system air dryer that incorporates the functions of the air dryer, purge reservoir (which increases the drying capacity), wet air tank, pressure relief valve, single check valves, and pressure protection valve for air susp and other air accessories. Includes easy-to-service spin-on desiccant cartridge.

Berg Pull Cord Drain Valve(s) - All Air Tanks

Nylon Chassis Hose

Steel Painted Air Tanks

All air tanks are steel with painted finish except when Code 4543330 Polish Aluminum Air Tanks is also selected (then exposed air tanks outside the frame rails will be polished aluminum). Peterbilt will determine the optimal size and location of required air tanks. Narratives requesting a specific air tank size or location will not be accepted for factory installation. See ECAT to determine number or location of air tanks installed.

7-Way Electric Harness with Socket Mounted EOF

Body Connections 5ft BOC

Junction Box contains light and power circuits for Body Connections located 5ft from BOC.

Tires & Wheels

FF: BR 20ply 315/80R22.5 M860A

Diameter = 42.8 inches; SLR = 19.9 inches

RR: BR 14ply 11R22.5 M843

Diameter = 42.5 inches; SLR = 19.9 inches

Code-rear Tire Qty 04

FF: Accur Std Armor 28039PK 22.5X9.00

PHP10-5 Hand Holes

RR: Accur Std Armor 50291PK 22.5X8.25

Heavy Duty, Two Hand Holes

Code-rear Rim Qty 04

Fuel Tanks

26in Aluminum 70 Gallon Fuel Tank LH U/C

Includes steps for cab access. Paddle handle filler cap with threadless filler neck. Top draw fuel plumbing reduces chance of introducing air into the fuel system during low fuel level conditions due to the central placement of fuel pickup tube. Wire braid fuel lines increase durability & reduce potential for leaks.

Location LH U/C 70 Gallon

DEF Tank Mounted LH BOC

Models 210, 220 and 320 mounted LH cab fender.

Standard DEF To Fuel Ratio 2:1 Or Greater

DEF Tank Small

Battery Box & Bumper

Aluminum Space Saver Battery Box RH BOC
Battery Access From Side

Rubber Battery Pad In Bottom Of (1) Battery Box
(Mat in box that holds batteries only)

Aftertreatment RH UIC Alum Non-Slip Cab Entry
Step. DPF/SCR for diesel engines, catalyst for natural gas engines. On Models 579 specifying chassis fairings, the box will be aerodynamic.

Steel Bumper Swept Back Painted Black, PERTO only
With two tow pin holes and step plates on top of bumper.

Cab & Equipment

Alum Cab 106in BBC Matton Hood w/Bright Crown
Includes view window RH door and convex mirror over RH door.

Severe Service Cab Package #1
Includes Aluminum side skins, aluminum rear skin, steel windshield mask, steel firewall, and steel front floor sheet on all cabs, and additional reinforcement structure on the back wall of the day cab.

Thermal Insulation Package in Cab
Includes thick, closed-cell foam in floor, special mylar-faced foam in walls and roof structure.

10 Inch Extension for Ultra Day Cab
Add additional 10" to the loadspace dimension— refer to the horizontal dimension workscreen.

Rubber Fender Lips 2 Inch Wide

Peterbilt UltraRide Driver Seat

Peterbilt UltraRide Passenger Seat

Drivers Armrest - RH Only

Required in Model 567 with Evolution LX seats. Optional with Evolution ST and Rolltek Seats.

Black Seat Color Ipo Standard Color

Air Ride Driver

High Back Driver

Vinyl Driver

Non-Air Ride Passenger

High Back Passenger

Vinyl Passenger

Adjustable Steering Column - Tilt/Telescope

Steering Wheel with Peterbilt Logo

Steering Wheel with embossed Peterbilt logo over horn button.

Interior Grey/Black

Includes rugged charcoal instrument panels, glare-resistant gray dash, black bezels on gauges, (2) power ports, monochromatic molded door pads with durable in-mold color, gray molded back wall, 18 inch 4-spoke soft-touch steering wheel, soft-touch steering column cover, power lift passenger window, extruded rubber floor covering, header-mounted dome light, foot wall lighting, integrated "dead pedal", (4) inside entry grab handles, (2) inside sunvisors, (2) coat hooks, (2) cup holders and map bin in dash.

Day Cab Rear Window

One Piece Curved Windshield

Combo Fresh Air Heater/Air Conditioner

With radiator mounted condenser, dedicated side window defrosters, 3-Level Heater/Defroster Controls, 54,500 BTU/HR, and silicone heater hoses.

Cup Holder (Floor Mounted)

Includes two standard-size drink holders and one extra-large jugholder, coin tray, and clipboard-size storage area.

Outside Sunvisor - Stainless Steel

Not available with 2.1M high roof sleeper.

Aero Mirrors Ea Side Hxd & Mirzrd 4-Way Adjustable
Bright Finish with Convex

Power Package
Includes power door locks and power windows.

(1) Air Horn 16in Painted
Mounted under cab.

Standard Speaker Package For Cab
(2) Speakers

ConcertClass Without CD, Includes BT Phone and
Audio, AM/FM, WB, USB and MP3.

CB Terminals/Wiring Mtd Under Header

Radio Antenna Mounted on LH Mirror Bracket

Plug-In Auto Reset Circuit Breaker
in place of fuses in junction box.

Peterbilt Electric Windshield Wipers
With intermittent feature.

Backup Alarm (107dB)

Air Restriction Indicator
Mounted on air cleaner or intake piping.

Bright Bezel Gauges

(2) Additional Electric Switches Without Wiring

Main Instrumentation Panel, Graphics Display
Includes speedometer with trip odometer, tachometer with hourmeter and
outside air temperature display, voltmeter, engine oil pressure, engine
coolant temperature, fuel level, primary and secondary air pressure
gauges. Includes standard warning light package: high water
temperature, low oil pressure, and low air pressure warning lights
w/audible alarms, high beam, turn signal, low fuel, parking brake, and ice
warning indicators; seat belt reminder; rocker switches with long-life LED
indicators; multi-function turn stalk with flash-to-pass feature (night mode
flashes headlights and marker lights; day mode flashes headlights only),
intermittent windshield wiper and headlamp beam control. Hydraulic
braked trucks do not include air pressure gauges.

(1) Additional Air Rocker, Guard
Indicator light, plumbed to firewall (occupies the space of one gauge).
Blank label.

Headlights Composite Fender Mounted
Integral Park, Turn, and Side Marker

(5) Marker Lights, Aero LED
Light Emitting Diodes

(2) SSTL Brkts Roof Mounted F/O Beacon/Strobe
Lights. Mounted above each door toward rear - Includes switch and wiring.

(2) Addl Dome/Reading Lights, Ceiling Mounted

LED Stop/Turn/Tail

40204 Backup, bracket mounted LHRH EOF

Movable EOF Xmbr For Mounting Taillights
Square EOF with or without EOF xenon.

Paint

Standard Paint Color Selection

(1) Color Axalta Two Stage - Cab/Hood

Base Coat/Clear Coat

N85020 A - L0006EY WHITE - Stand

N85400 HOOD TOP L0006EY WHITE - Stand

N85500 CAB ROOF L0006EY WHITE - Stand

N85200 FRAME N0001EA BLACK

N85700 BUMPER N0001EA BLACK

N85300 FENDER L0006EY WHITE - Stand

Options Not Subject To Discount

PACCAR 2013 PX-9 Protection Plan 1 (5/100)

Five Years/100,000 Miles/160,935 Kilometers. Coverage is 100 percent
parts and labor with no deductibles on internally lubricated components
and major engine systems including turbo charger, water pump, and fuel
injectors.

PACCAR 2013 PX-9 Aftertreatment Coverage (5/100)

Five Years/100,000 Miles/160,935 Kilometers. Coverage is 100 percent parts and labor with no deductibles on the DEF controller / dosing unit / dosing valve, SCR catalyst, catalytic converter particulate filter, SCR/DPF temperature sensor interface module, and other related aftertreatment parts as detailed in Cummins Bulletin #3381446.

Medium Duty Emissions Surcharge

Miscellaneous

Total Weight

12521

Prices and Specifications Subject to Change Without Notice.

Unpublished options may require review/approval.

Dimensional and performance data for unpublished options may vary from that displayed in PROSPECTOR.

Printed:	3/22/2016 10:02:21 AM	<i>incomplete</i>	Model Number:	Model 348
Effective Date:	Jan 1, 2016		Quote/DTPO/CO:	Q75812223
Prepared by:	ID: mich		Version Number:	32.11



Henderson Truck Equipment-Illinois
124 Industrial Drive
Gilberts, IL. 60136

Toll Free: 888-360-7483
Office: 847-836-4996
Cell: 815-503-2004

Quote

Date: 4/8/2016
To: Rick Michalowski
By: Norm LaValla
Re: City of Darien SA w/ Chipper cap

Hydraulics, Lighting and cab controls the exact same as tandem
Revised added back up camera and spill shields.

Henderson Truck Equipment-Illinois is pleased to quote the following equipment:

MKESA 10' w/ Internal dog house.

Body Length: 10'
Internal dog house
201 SS 1/4 Cab Shield w/integral tarp shroud
30" slides
201 SS, Sloped Removable Side Boards
Tailgate: 38" w/8" Board Pockets
201 SS sides & Ends
Floor 1/4" AR400
Hoist CS90-4.5-3DA, Nitrited
Rear Hinge Structural Angle 8" X 6" X 1/2"
Composite Greasless Bushings
Body-up Light
Backup Alarm
Vibrator
(2) pull out ladders. (2) fixed ladders weled to body
Pull style tarp with asphalt rated material

Henderson Products Truck Hitch

Quick Hitch
Flat Fold Style
4" x 2" x 10" DA Lift Cylinder, Nitrited
3 point Lift, Lift arm 4"x4"x3/8" outer and 3x3x3/4" Inner
Lift Lug 1/2" plate w/key holes

Henderson Products RSP SNOWFOE 11' TE OC

11' Plow Length, 42" moldboard w/integral shield
Adjustable torsion trip edge, (5) 3/4" square torsion springs
HD outboard cylinder type
Quick Hitch
3/8" poly moldboard
(3) attack angles 5, 15 or 20 degrees
(6) moldboard to push tube frame pivot points
12" rubber deflector, 36" side markers, Screw adjustable parking Jack

Henderson Tailgate spreader

TGS-201-SS-DD-TS
201 SS construction
Direct Drive 6" auger
Taller Sides
Motor w/integral speed sensor w/M12 connection

Towing

Pintle plate, 3/4"
Pintle hook, PH45

Lighting

Remount Factory S/T/T

(6) LED 6" amber warns mounted in cab shield, four front mounted 2 ea side, 2 side mounted 1 ea side.

(2) 6" LED oval warning light, Mounted Rear Corner Post

(2)LED S/T/T & (2)LED Back up Light mounted in rear corner post

(2) ABL Work lights 12 LED 2000 Lumen, Mounted on Stainless steel cab roof mount 20k hours or 4 year warranty

ABL Plow Lights Mounted on 201 SS brackets

Heated spot mirrors mounted on plow light bracket

2 ABL work lights led 850 spinner lights. 20k hours or 4 year warranty

Red and white reflective tape

Central Hydraulics

690 Series Hot Shift PTO

Load Sensing Pump Direct Mount, Wet Spline

3-spool air operated valve w/manifold for auger, spinner

Air Operated Valves

Adjustable floor console

6 switch, switch pac

Freedom 2 Spreader control (Certified Power)

SS hydraulic reservoir, valve enclosure

SS tubing to rear

SS hydraulic quick couplers

Misc

201 SS chipper cap similar to what Darien has-----

36" tall x 60" wide at top x 87" wide a bottom x 120" long

201 SS 1/2 Height Secondary tailgate

3 louvered sets per side. Will mount similar to existing chip cap.

Double acting w/ Quick Release lever

like a 1 ton dump body

Safety Lane

Wash, Clean, Vacuum

Deliver To End User

Back up camera system includes Wash & Dry, Color Camera, Color Monitor

Special Salt Spill Shields. Stays in-contact with floor of dump body through arc/swing of tailgate.

Price per Unit:	\$77,625.00
Number of Units	1
Extended Price	\$77,625.00
Tax	
Total Quote Price	\$77,625.00

FOB Gilberts, IL

Please note the following regarding installation quotes:

A clean truck frame without obstruction is assumed in the pricing of our quote. Re-positioning of air tanks, fuel tanks or other obstacles to the ease of installation may require additional charges. Henderson will notify you before modification if this occurs.

JAKE THE STRIPER ★ 1071 WESTON CIRCLE ★ BATAVIA, IL 60510

PROPOSAL

CITY OF DARIEN
MUNICIPAL SERVICES
1041 S. FRONTAGE ROAD
DARIEN, ILLINOIS 60561

December 1, 2015

QUOTE Estimate for graphics for 2016.

PUBLIC WORKS TRUCK GRAPHICS PACKAGE

PER: LAYOUT SUBMITTED
ALL GRAPHICS WILL BE PRINTED & REFLECTIVE
REAR White conspicuity safety striping
THREE SETS OF UNIT NUMBERS
A protective gloss laminate coating will be applied to all printed format
Please note:
Removal of any old graphics will based on a additional quote

*Truck # 105
\$ 915.00
for
Graphics*

MATERIALS & WORKMANSHIP IS GUARANTEED FOR 5 YEARS

PRICE BASED ON 1 UNITS Smaller Units \$715.00 PER UNIT
Larger Dumps with 5" lettering and additional safety stripes. Add \$200.00 PER UNIT

ACCEPTED: _____ DATE _____

If you have any questions please do not hesitate to call me. Thank You.

SINCERELY



JAKE M. ZAAGMAN



EMERGENCY VEHICLE GRAPHICS

Ph. 630.879.2525
JAKETHESTRIPER.COM
JAKETHESTRIPER@aol.com



Henderson Truck Equipment-Illinois
124 Industrial Drive
Gilberts, IL 60136

Toll Free: 888-360-7483
Office: 847-836-4998
Cell: 815-509-2004

Quote

Hydraulics, Lighting and cab controls the exact same as tandem

Date: 11/29/2015
To: Rick Michaloweld
By: Norm LaValla
Re: City of Darien SA w/ Chipper cap

Henderson Truck Equipment-Illinois is pleased to quote the following equipment:

MKESA 10' w/ Internal dog house.

Body Length: 10'
Internal dog house
201 SS 1/4 Cab Shield w/integral tarp shroud
30" sides
201 SS, Sloped Removable Side Boards
Tailgate: 38" w/8" Board Pockets
201 SS sides & Ends
Floor 1/4" AR400
Hoist CS90-4.5-3DA, Nitrated
Rear Hinge Structural Angle 8" X 6" X 1/2"
Composite Grassless Bushings
Body-up Light
Backup Alarm
Vibrator
(2) pull out ladders. (2) fixed ladders welded to body
Pull style tarp with asphalt rated material

Henderson Products Truck Hitch

Quick Hitch
Flat Fold Style
4" x 2" x 10" DA Lift Cylinder, Nitrated
3 point Lift, Lift arm 4"x4"x3/8" outer and 3x3x3/4" inner
Lift Lug 1/2" plate w/key holes

Henderson Products RSP SNOWFOE 11' TE OC

11' Plow Length, 42" moldboard w/integral shield
Adjustable torsion trip edge, (5) 3/4" square torsion springs
HD outboard cylinder type
Quick Hitch
3/8" poly moldboard
(3) attack angles 5, 15 or 20 degrees
(6) moldboard to push tube frame pivot points
12" rubber deflector, 36" side markers, Screw adjustable parking jack

Henderson Tailgate spreader

TGS-201-SS-DD-TS
201 SS construction
Direct Drive 6" auger
Tailer Sides
Motor w/integral speed sensor w/M12 connection

Towing

Pinite plate, 3/4"
Pinite hook, PH45
7 Way Connector, Round Socket, round pin

Henderson Truck Equipment - Illinois

Lighting

Remount Factory S/T/T

(8) LED 8" amber warns mounted in cab shield, four front mounted 2 ea side, 2 side mounted 1 ea side.

(2) 6" LED oval warning light, Mounted Rear Corner Post

(2) LED S/T/T & (2) LED Back up Light mounted in rear corner post

(2) ABL Work lights 12 LED 2000 Lumen, Mounted on Stainless steel cab roof mount. 20k hours or 4 year warranty.

ABL Plow Lights Mounted on 201 SS brackets

Heated spot mirrors mounted on plow light bracket

2 ABL work lights led 850 spinner lights. 20k hours or 4 year warranty.

Red and white reflective tape

Central Hydraulics

890 Series Hot Shift PTO

Load Sensing Pump Direct Mount, Wet Spline

3-spool air operated valve w/manifold for auger, spinner

Air Operated Valves

Adjustable floor console

6 switch, switch pac

Freedom 2 Spreader control (Certified Power)

SS hydraulic reservoir, valve enclosure

SS tubing to rear

SS hydraulic quick couplers

Misc

201 SS chipper cap similar to what Darien ~~1250~~

36" tall x 80" wide at top x 87" wide at bottom x 120" long

201 SS 1/2 Height Secondary tailgate

3 lowered sets per side. Will mount similar to existing chip cap.

Double acting w/ Quick Release lever

like a 1 ton dump body

Safety Lany

Wash, Clean, Vacuum

Deliver To End User

RESOLUTION NO. _____

A RESOLUTION AUTHORIZING THE MAYOR AND CITY CLERK TO ACCEPT A PROPOSAL FROM JX ENTERPRISES, INC. FOR THE PURCHASE OF ONE NEW 2017 PETERBILT MODEL 348 WITH DUMP BODY AND SNOW PLOW/DEICING EQUIPMENT PACKAGE IN THE AMOUNT OF \$174,910

BE IT RESOLVED BY THE CITY COUNCIL OF THE CITY OF DARIEN, DU PAGE COUNTY, ILLINOIS, as follows:

SECTION 1: The City Council of the City of Darien hereby authorizes the Mayor and City Clerk to accept a proposal from JX Enterprises, Inc. for the purchase of one new 2017 Peterbilt Model 348 with dump body and snow plow/deicing equipment package in an amount not to exceed \$174,910.00, a copy of which is attached hereto as "**Exhibit A**".

SECTION 2: This Resolution shall be in full force and effect from and after its passage and approval as provided by law.

PASSED BY THE CITY COUNCIL OF THE CITY OF DARIEN, DU PAGE COUNTY, ILLINOIS, this 2nd day of May, 2016.

AYES: _____

NAYS: _____

ABSENT: _____

APPROVED BY THE MAYOR OF THE CITY OF DARIEN, DU PAGE COUNTY, ILLINOIS, this 2nd day of May, 2016.

KATHLEEN MOESLE WEAVER, MAYOR

ATTEST:

JOANNE E. RAGONA, CITY CLERK

APPROVED AS TO FORM

CITY ATTORNEY



535 E. South Frontage Rd / Bolingbrook, IL / 60440

Date: 4-11-2016

To: Village of Darien
Kris Throm
1041 Frontage Rd
Darien, IL. 60561

REF: Lake County DOT Joint Purchase # 15015

Dear Kris,

We are pleased to quote the following Peterbilt Model 348 Single AXLE per the attached summary which utilizes the Lake County Joint Purchase Contract number 15015 pricing with the specification discussed to accommodate the Village of Darien's requirements .

2017 Peterbilt Model 348

Same as 2016 Tandem Specifications w/ extended cab
Henderson Equipment / 10' dump with Options included.

Heated Windshield

5 Year / 150,000 mile engine warranty

Title and Plates

All As Per Attached

Lake County Joint Purchase agreement 15015

Total Sale **\$ 174,910.00**

Municipal FET and Sales Tax Exempt // Final Payment Due Upon Delivery

Rick Michalowski | Vocational Account Manager
JX Enterprises, Inc.
Cell 708-207-2354 | Fax 708-460-8991
rmichalowski@jxe.com
www.JXE.com

FORM D



Formal Offering of Proposal
(To be completed Only by Proposer)

SNOW AND ICE HANDLING EQUIPMENT WITH RELATED ACCESSORIES, SERVICES, AND SUPPLIES

In compliance with the Request for Proposal (RFP) for SNOW AND ICE HANDLING EQUIPMENT WITH RELATED ACCESSORIES, SERVICES, AND SUPPLIES the undersigned warrants that I/we have examined this RFP and, being familiar with all of the instructions, terms and conditions, general specifications, expectations, technical specifications, service expectations and any special terms, do hereby propose, fully commit and agree to furnish the defined equipment/products and related services in full compliance with all terms, conditions of this RFP, any applicable amendments of this RFP, and all Proposer's Response documentation. Proposer further understands they accept the full responsibility as the sole source of responsibility of the proposed response herein and that the performance of any sub-contractors employed by the Proposer in fulfillment of this proposal is the sole responsibility of the Proposer.

Company Name: HENDERSON PRODUCTS INC Date: AUG 6 2014

Company Address: 1085 SOUTH 3RD STREET PO BOX 40

City: MANCHESTER State: IA Zip: 52051

Contact Person: GLENN BECK Title: VP SALES & MARKETING

Authorized Signature (Ink only):  GLENN BECK
(Name printed or typed)

Form E



Contract Acceptance and Award

(To be completed only by NJPA)

NJPA 000114 SNOW AND ICE HANDLING EQUIPMENT WITH RELATED ACCESSORIES, SERVICES, AND SUPPLIES

HENDERSON PRODUCTS, INC.
Proposer's full legal name

Your proposal is hereby accepted and awarded. As an awarded Proposer, you are now bound to provide the defined product/equipment and services contained in your proposal offering according to all terms, conditions, and pricing set forth in this RFP, any amendments to this RFP, your Response, and any exceptions accepted or rejected by NJPA on Form C.

The effective start date of the Contract will be October 21, 20 14 and continue for four years from the board award date. This contract has the option of a one year renewal option at the discretion of NJPA.

National Joint Powers Alliance (NJPA)

NJPA Authorized signature:

NJPA Executive Director

Dr. Chad Corvette

(Name printed or typed)

Awarded this 21st day of October, 20 14 NJPA Contract Number 000114-NJPA

NJPA Authorized signature:

NJPA Board Member

Scott Veronen

(Name printed or typed)

Executed this 21st day of October, 20 14 NJPA Contract Number 000114-NJPA

Proposer hereby accepts contract award including all accepted exceptions and NJPA clarifications identified on Form C.

Vendor Name Henderson Products Inc

Vendor Authorized signature:

Glenn Beck

(Name printed or typed)

Title: VP Sales & Marketing

Executed this 23rd day of October, 20 14 NJPA Contract Number 000114-NJPA

NO HIDDEN CHARGES

**NITPA AWARDED
CONTRACT**

Henderson®

ALL-INCLUSIVE PACKAGES:

**PRICING INCLUDES EQUIPMENT, HYDRAULICS, INSTALLATION...
AND DELIVERY!**



NO LIABILITY • NO COST • NO OBLIGATION
JOIN FREE

**REGISTER TODAY
TO PURCHASE OFF THE CONTRACT!**

<http://www.njpacoop.org/national-cooperative-contract-solutions/join-njpa/>

CONTRACT 080114-HPI

NJPA AWARDED CONTRACT

CONTRACT NUMBER

080114-HPI

PRICING INCLUDES EQUIPMENT, HYDRAULICS, INSTALLATION AND DELIVERY!

DELIVERIES & INSTALLATION

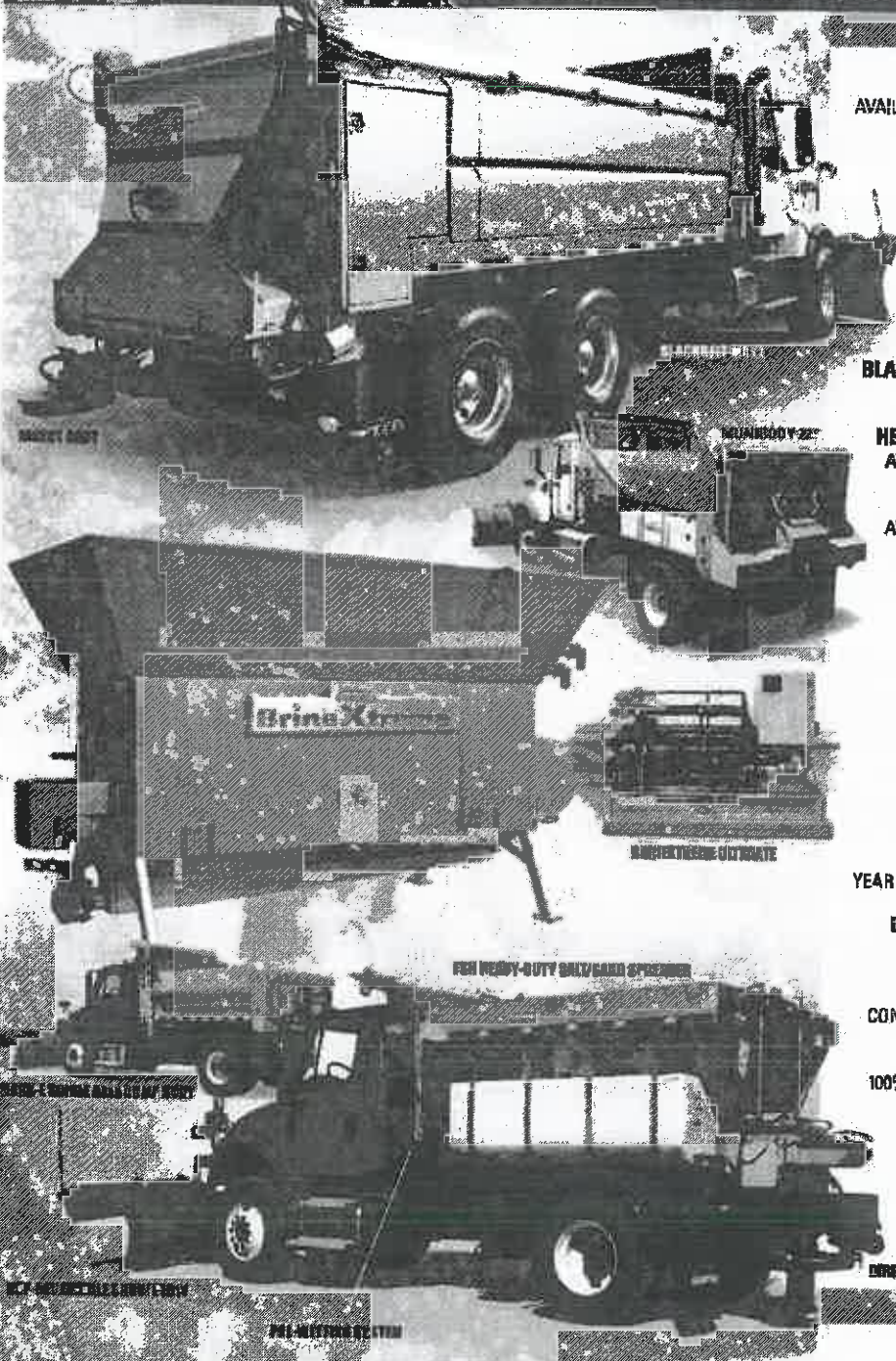

RSP - REVERSIBLE SNOW PLOW
AVAILABLE IN POLY, MILD STEEL OR STAINLESS STEEL MOLDBOARD

MARK-E SINGLE AXLE DUMP BODY
AVAILABLE IN MILD OR STAINLESS STEEL

MARK-E TANDEM AXLE DUMP BODY
AVAILABLE IN MILD OR STAINLESS STEEL

MUNIBODY (22° OR 35° SLOPED SIDES)
COMBINATION DUMP BODY & SPREADER
AVAILABLE IN MILD OR STAINLESS STEEL

BLACKBELT MAXX ALL-SEASON MULTI-PURPOSE BODY
AN ADVANCED COMBINATION BODY

HENDERSON WING SYSTEMS (CABLE OR HYDRAULIC)
AVAILABLE WITH MILD OR STAINLESS STEEL MOLDBOARD

UNDERBODY SCRAPER (FIXED OR REVERSING)
AVAILABLE WITH MILD OR STAINLESS STEEL MOLDBOARD

FSH - HEAVY-DUTY SALT/SAND SPREADER
AVAILABLE IN MILD OR STAINLESS STEEL

TGS - TAILGATE SPREADER
LOW MAINTENANCE SPREADER
AVAILABLE IN MILD OR STAINLESS STEEL

PRE-WETTING SYSTEMS
HYDRAULIC OR ELECTRIC CONTROLS

FIRST RESPONSE SYSTEM
4-IN-1 ADVANCED ANTI-ICING & DEICING SYSTEM

LAS - LIQUID APPLICATION SYSTEM
YEAR ROUND USE, EASILY SLIPS INSIDE EXISTING DUMP BODIES

DIRECT CAST - PRECISION PLACEMENT SPINNER
ON-THE-GO DIRECTIONAL CONTROL PRECISION CAST

BRINEXTREME PRO
CONTINUOUS BRINE PRODUCTION SYSTEM-UP TO 6,000 GPH

BRINEXTREME ULTIMATE
100% AUTOMATION, REPEATABILITY & SELF CLEANING WITH
CONTINUOUS BRINE PRODUCTION UP TO 8,600 GPH

BRINEXTREME MOBILE UNIT
MOBILIZE! 100% AUTOMATION, REPEATABILITY
& SELF CLEANING WITH CONTINUOUS
BRINE PRODUCTION UP TO 8,600 GPH

201 STAINLESS STEEL
304 STAINLESS STEEL
409 STAINLESS STEEL
MILD STEEL GRADE 50
AR400
POLYMER MOLDBOARD

TO ORDER CONTACT:



HENDERSON PRODUCTS, INC.

JANET TOBIN | CONTRACT ADMINISTRATOR
(563) 927-7267

1085 South Third Street, Manchester, IA 52057

jtobin@hendersonproducts.com

www.hendersonproducts.com

AGENDA MEMO
Municipal Services Committee Meeting
April 25, 2016

ISSUE STATEMENT

A resolution authorizing the purchase of one new 2016 Ford Expedition Carryall Unit from Roesch Ford in the amount of \$35,474.

BACKGROUND/HISTORY

The proposed vehicle is to be utilized by the Street Foreman. The proposed vehicle would be replacing unit 503, a 2006 Ford Expedition. The vehicle was handed down from the Police Department in 2011. The vehicle has approximately 145,000 miles and is severely rusted through in several quadrants including the floor board. The vehicle has a history of various repairs and ongoing mechanical issues (attached and labeled as Attachment A) and has served its useful life.

The new vehicle would primarily be utilized by the street foreman to oversee department projects and contractual work throughout the city. The cargo room would allow the foreman to mobilize the larger informational signs for the crack fill and road paving program. The cargo area would also serve as storage area for miscellaneous tools, marking, measuring and miscellaneous project supply carrier. The vehicle would also serve as a mobile office for field observations, recording of project quantities and to transport vendors or employees to discuss site issues or proposed projects.

Staff has selected Roesch Ford for the awarded vendor as Roesch Ford is the awarded vendor for the Suburban Purchasing Cooperative for fleet sales to municipalities. While the City of Darien is not a member of the Suburban Purchasing Cooperative we are allowed to participate in the program. Attached and labeled as Attachment B, please find information regarding the Suburban Purchasing Cooperative and a detailed cost breakdown for the 2016 Ford Expedition Carryall Unit.

The proposed expenditure would be expended from the following line account:

ACCOUNT NUMBER	ACCOUNT DESCRIPTION	FY 16/17 BUDGET	PROPOSED EXPENDITURE	PROPOSED BALANCE
01-30-4815	CAPITAL PURCHASES TRUCK REPL UNIT 503	\$ 36,800	\$ 35,474	\$ 1,326
01-30-4815	CAPITAL PURCHASES TRUCK DECALS	N/A	\$ 700	\$ 626

STAFF/COMMITTEE RECOMMENDATION

Staff recommends approval of the resolution authorizing the purchase of one (1) new 2016 Ford Expedition Carryall Unit from Roesch Ford in the amount of \$35,474.

ALTERNATE DECISION

As recommended by the Committee.

2016 Ford-Carry All Unit 503
April 25, 2016
Page 2

DECISION MODE

This item will be on the May 2, 2016 City Council agenda for formal consideration.

CRITERIA FOR REPLACING CITY VEHICLES AND EQUIPMENT				
UNIT NO	503	DEPARTMENT	Street	DATE
MODEL YEAR	2006	MODEL	Expedition	10-29-15
CURRENT MILEAGE	139,305	CURRENT HOURS		
			MAXIMUM POINTS	VEHICLE SCORE
AGE				
	Department	Street		
	Life Expectancy	10		
	Age as of Report Date	9		
	AGE: Meets Requirements		20	18
USAGE				
	MILES	139,305		
	HOURS			
	ATTACHMENT C OF THE VEHICLE REPLACEMENT POLICY			
	USAGE: Meets Requirements		20	20
TYPE OF SERVICE				
	1-LIGHT DUTY			
	15-CRITICAL DUTY			
	SERVICE: Meets Requirements		15	4
RELIABILITY				
	RELIABILITY: Frequency or Visits for Service			
	RELIABILITY: Meets Requirements		15	4
MAINTENANCE AND REPAIR COSTS				
	REPAIRS: Cost per Mile/Hours Exceeds Vehicle in Class			
	ORIGINAL PURCHASE PRICE	0		
	LIFE TO DATE REPAIR COST	8,062.24		
	PERCENTAGE OF REPAIRS TO PURCHASE PRICE	100%		

UNIT NO	503	DEPARTMENT	Street	DATE
MODEL YEAR	2006	MODEL	Expedition	10-29-15
CURRENT MILEAGE	139,305	CURRENT HOURS		
			MAXIMUM POINTS	VEHICLE SCORE
PERCENTAGES OF REPAIR POINTS	POINTS			
1 THROUGH 20	2			
21 THROUGH 40	4			
41 THROUGH 60	6			
61 THROUGH 80	8			
81 THROUGH 100	10			
	REPAIRS: Meets Requirements		10	10
CONDITION				
	CONDITION OF ENGINE COMPONENTS (MAJOR REPAIRS NEEDED OR ANTICIPATED), BODY (BODY SHEET METAL RUSTED, STRUCTURAL COMPONENTS)			
	CONDITION: Meets Requirements		15	15
TECHNOLOGICAL ADVANCEMENTS	FUEL EMISSIONS, SAFETY FEATURES, ERGONOMICS		5	5
TOTAL POINTS			100	76

CITY OF DARIEN
 Repair Transaction Cost Detail

Equipment#	Repair Order#	Date	Meter(1)	Shop Loc/ Rep Class	Rep Reason/ Rep Site			
503	0000027241	04/17/07	5468	/01	08/01			
	<u>Group-System</u>			<u>Mech/Vendor</u>	<u>Work Acc</u>	<u>Part(\$)</u>	<u>Labor(\$)</u>	<u>Hours</u>
	01-PMA - PREV. MAINT.			002		13.45	7.50	0.50
503	0000027329	06/11/07	9660	/01	08/01			
	01-PMA - PREV. MAINT.			001		13.45	14.00	0.50
503	0000027411	08/31/07	15654	/01	08/01			
	01-PMA - PREV. MAINT.			002		16.20	7.50	0.50
503	0000027531	11/26/07	21165	/01	08/01			
	01-PMA - PREV. MAINT.			001		16.15	14.00	0.50
	01-PMB - PREV. MAINT.			001		0.00	28.00	1.00
	01-PMC - PREV. MAINT.			001		33.74	14.00	0.50
	02-17 - TIRES,TUBES,ETC			001		8.00	14.00	0.50
503	0000027718	02/11/08	26450	/01	08/01			
	01-PMA - PREV. MAINT.			001		16.15	14.00	0.50
503	0000027785	04/04/08	29900	/01	08/01			
	01-PMA - PREV. MAINT.			001		15.64	14.00	0.50
503	0000027925	06/05/08	33110	/01	08/01			
	01-PMA - PREV. MAINT.			001		15.65	14.00	0.50
503	0000027985	08/04/08	36870	/01	08/01			
	01-PMA - PREV. MAINT.			001		15.65	14.00	0.50
503	0000028066	09/29/08	40950	/01	08/01			
	01-PMA - PREV. MAINT.			001		16.60	14.00	0.50
	04-13 - BRAKES			001		232.93	56.00	2.00
	03-10 - WIPERS/WASHERS			001		17.96	14.00	0.50
503	0000028073	10/06/08	41380	/01	08/01			
	01-PME - PREV. MAINT.			001		0.00	28.00	1.00
503	0000028119	11/07/08	43734	/01	08/01			
	01-PMC - PREV. MAINT.			001		29.94	28.00	1.00
503	0000028166	12/05/08	44939	/01	08/01			
	01-PMA - PREV. MAINT.			001		16.60	14.00	0.50
503	0000028221	01/22/09	48187	/01	08/01			
	01-PMB - PREV. MAINT.			002		0.00	7.50	0.50
	06-35 - BATTERY			002		140.00	7.50	0.50
503	0000028242	02/05/09	49135	/01	08/01			
	01-PMA - PREV. MAINT.			001		25.39	28.00	1.00
503	0000028284	03/18/09	51440	/01	08/01			
	01-PMD - PREV. MAINT.			001		340.48	28.00	1.00
503	0000028305	04/06/09	53225	/01	08/01			
	01-PMA - PREV. MAINT.			001		16.60	14.00	0.50
503	0000028402	06/11/09	57359	/01	08/01			
	03-02 - HEATER-VENT			002		19.44	15.00	1.00
503	0000028448	07/15/09	60108	/01	08/01			
	01-PMA - PREV. MAINT.			002		15.64	7.50	0.50
503	0000028450	07/22/09	60150	/01	08/01			
	01-PMB - PREV. MAINT.			002		92.97	30.00	2.00
503	0000028538	10/05/09	65920	/01	08/01			

CITY OF DARIEN
 Repair Transaction Cost Detail

Equipment#	Repair Order#	Date	Meter(1)	Shop Loc/ Rep Class	Rep Reason/ Rep Site			
	01-PMA - PREV. MAINT.			001		16.53	14.00	0.50
	01-PMC - PREV. MAINT.			001		17.65	28.00	1.00
503	0000028610	11/12/09	66932	01/02	01/01			
	<u>Group-System</u>			<u>Mech/Vendor</u>	<u>Work Acc</u>	<u>Part(\$)</u>	<u>Labor(\$)</u>	<u>Hours</u>
	03-02 - HEATER-VENT			002		117.08	15.00	1.00
503	0000028669	01/08/10	70673	01/01	08/01			
	01-PMA - PREV. MAINT.			002		16.53	15.00	1.00
503	0000028731	02/16/10	73078	01/02	01/01			
	07-44 - FUEL SYS			002		0.00	33.75	2.25
	03-02 - HEATER-VENT			001		0.00	42.00	1.50
503	0000028747	03/04/10	73920	01/01	08/01			
	01-PMA - PREV. MAINT.			001		16.08	28.00	1.00
503	0000028826	05/07/10	77860	01/01	08/01			
	01-PMA - PREV. MAINT.			001		39.54	28.00	1.00
503	0000028841	05/19/10	78552	01/02	01/01			
	06-34 - LIGHTING SYS			002		54.04	15.00	1.00
503	0000028895	07/14/10	81056	01/02	01/01			
	06-34 - LIGHTING SYS			002		28.76	15.00	1.00
503	0000028927	08/06/10	83060	01/01	08/01			
	01-PMA - PREV. MAINT.			001		15.50	28.00	1.00
	01-PME - PREV. MAINT.			001		0.00	28.00	1.00
503	0000028947	08/26/10	84220	01/02	01/01			
	06-35 - BATTERY			001		109.00	14.00	0.50
503	0000028979	09/22/10	85440	01/02	01/01			
	01-PMB - PREV. MAINT.			001		349.22	28.00	1.00
503	0000029040	11/08/10	87610	01/01	08/01			
	01-PMA - PREV. MAINT.			001		15.50	28.00	1.00
	01-PMC - PREV. MAINT.			001		41.66	28.00	1.00
503	0000029058	11/15/10	87798	01/02	01/01			
	06-33 - IGNITION SYS			002		68.39	15.00	1.00
503	0000029139	02/14/11	92766	01/01	08/01			
	01-PMA - PREV. MAINT.			001		15.33	14.00	0.50
503	0000029189	03/28/11	93523	01/02	01/01			
	03-02 - HEATER-VENT			002		54.71	22.50	1.50
503	0000029224	04/27/11	95500	01/02	01/01			
	06-33 - IGNITION SYS			001		68.39	28.00	1.00
503	0000029266	05/17/11	96470	01/02	01/01			
	04-13 - BRAKES			001		199.93	56.00	2.00
503	0000029272	05/23/11	96740	01/01	08/01			
	06-35 - BATTERY			002		100.00	15.00	1.00
503	0000029290	06/08/11	97900	01/01	08/01			
	01-PMA - PREV. MAINT.			001		15.50	28.00	1.00
503	0000029335	07/18/11	100342	01/03	01/01			
	03-02 - HEATER-VENT			002		29.39	15.00	1.00
503	0000029347	07/25/11	100571	01/03	01/01			
	04-13 - BRAKES			002		45.04	15.00	1.00

CITY OF DARIEN
 Repair Transaction Cost Detail

Equipment#	Repair Order#	Date	Meter(1)	Shop Loc/ Rep Class	Rep Reason/ Rep Site			
	06-33 - IGNITION SYS			002		55.95	15.00	1.00
503	0000029386	08/25/11	101973	01/02	01/01			
	<u>Group-System</u>			<u>Mech/Vendor</u>	<u>Work Acc</u>	<u>Part(\$)</u>	<u>Labor(\$)</u>	<u>Hours</u>
	04-13 - BRAKES			002		534.68	45.00	3.00
503	0000029399	09/06/11	102460	01/01	08/01			
	01-PMD - PREV. MAINT.			002		120.48	30.00	2.00
503	0000029422	09/26/11	103390	01/02	01/01			
	04-18 - HUB/BEARNG/SEAL			002		1,102.90	60.00	4.00
503	0000029439	10/10/11	104036	01/01	08/01			
	01-PMA - PREV. MAINT.			002		15.31	15.00	1.00
503	0000029522	12/15/11	108460	01/02	01/01			
	06-34 - LIGHTING SYS			002		12.50	7.50	0.50
503	0000029535	12/05/11	107468	01/02	01/01			
	01-PMA - PREV. MAINT.			002		16.28	30.00	2.00
	06-33 - IGNITION SYS			002		55.95	7.50	0.50
	01-PMC - PREV. MAINT.			002		19.50	15.00	1.00
	01-PMC - PREV. MAINT.			002		27.20	3.75	0.25
	07-41 - AIR INTAKE SYS			002		23.92	3.75	0.25
	06-40 - TURN SIGNALS			002		107.81	30.00	2.00
503	0000029589	01/26/12	109959	01/02	01/01			
	06-31 - CHARGING SYS			002		281.78	60.00	4.00
	07-41 - AIR INTAKE SYS			002		30.00	7.50	0.50
503	0000029637	02/29/12	111084	01/01	08/01			
	06-34 - LIGHTING SYS			002		0.00	75.00	5.00
503	0000029655	03/09/12	111220	01/01	08/01			
	01-PMA - PREV. MAINT.			002		15.77	15.00	1.00
503	0000029695	04/24/12	112373	01/01	08/01			
	05-27 - XMISSION AUTO			002		115.46	90.00	6.00
	07-42 - COOLING SYS			002		129.00	0.00	0.00
503	0000029803	07/09/12	114146	01/03	01/01			
	04-15 - STEERING			002		163.99	15.00	1.00
503	0000029819	07/18/12	114465	01/03	01/01			
	03-06 - DOORS			002		68.76	7.50	0.50
503	0000029825	07/19/12	114720	01/03	01/01			
	03-10 - WIPERS/WASHERS			002		200.88	15.00	1.00
503	0000029860	08/16/12	115206	01/01	08/01			
	01-PMA - PREV. MAINT.			002		31.89	15.00	1.00
	07-41 - AIR INTAKE SYS			002		25.06	0.00	0.00
	07-42 - COOLING SYS			002		66.74	15.00	1.00
503	0000029885	09/11/12	115754	01/03	01/01			
	03-07 - INTERIOR			002		100.33	90.00	6.00
503	0000030154	05/02/13	120113	01/03	01/01			
	07-46 - BELTS			002		48.29	7.50	0.50
503	0000030183	05/22/13	121104	01/01	08/01			
	01-PMA - PREV. MAINT.			002		29.80	7.50	0.50
	01-PMB - PREV. MAINT.			002		0.00	7.50	0.50
503	0000030184	05/23/13	121131	01/01	01/01			

CITY OF DARIEN
 Repair Transaction Cost Detail

Equipment#	Repair Order#	Date	Meter(1)	Shop Loc/ Rep Class	Rep Reason/ Rep Site			
	02-17 - TIRES,TUBES,ETC			002		327.36	15.00	1.00
503	0000030272	08/20/13	123440	01/03	01/01			
	<u>Group-System</u>			<u>Mech/Vendor</u>	<u>Work Acc</u>	<u>Part(\$)</u>	<u>Labor(\$)</u>	<u>Hours</u>
	06-35 - BATTERY			002		138.18	7.50	0.50
503	0000030379	12/20/13	126229	01/01	08/01			
	01-PMA - PREV. MAINT.			002		29.80	15.00	1.00
	01-PME - PREV. MAINT.			002		0.00	3.75	0.25
503	0000030544	06/10/14	130050	01/01	08/01			
	01-PMA - PREV. MAINT.			002		29.80	7.50	0.50
	01-PMC - PREV. MAINT.			002		57.77	15.00	1.00
503	0000030576	07/08/14	130666	01/03	01/01			
	04-13 - BRAKES			002		288.11	22.50	1.50
503	0000030695	10/21/14	136380	01/01	08/01			
	06-33 - IGNITION SYS			002		618.46	90.00	6.00
503	0000030735	12/01/14	134475	01/01	08/01			
	01-PMA - PREV. MAINT.			002		34.20	15.00	1.00
503	0000030913	06/10/15	137689	01/03	01/01			
	05-27 - XMISSION AUTO			002		1,900.00	0.00	0.00
503	0000030959	07/29/15	139305	01/03	01/01			
	01-PMA - PREV. MAINT.			002		34.20	15.00	1.00
	02-17 - TIRES,TUBES,ETC			002		606.00	22.50	1.50
				Grand Total		<u>10,026.51</u>	<u>1,961.50</u>	<u>106.50</u>

NWMC Web Site - Suburban Purchasing Cooperative



The Suburban Purchasing Cooperative is a joint purchasing program sponsored by the Northwest Municipal Conference (NWMC), DuPage Mayors & Managers Conference (DMMC) South Suburban Mayors and Managers Association (SSMMA), and Will County Governmental League (WCGL). Together the SPC represents 143 municipalities and townships in northeastern Illinois.

The following entities are eligible to participate in the SPC joint purchasing programs: Municipalities, Townships, Counties, Fire Protection Districts, Park Districts, Libraries, School Districts and Non-Profit Organizations.

The SPC exemplifies the benefits of intergovernmental cooperation on a regional basis. The goal of the SPC is to combine the resources and purchasing power of governments and not-for-profit entities to jointly negotiate advantageous contract terms on a line of high quality products at the lowest possible price.

Economies of scale in terms of pricing and staff resources are the prime objectives of the SPC Joint Purchasing Program. By purchasing through the SPC, participants not only save money but time as well. Acting as an extension of the purchaser's staff, SPC staff works diligently in order to avoid the needless duplication of effort through in-house coordination of several functions involved in the procurement process.

According to 30ILCS 525/2 from CH. 85, pr. 1602 Sec. 2 (a) Any governmental unit may purchase personal property, supplies and services jointly with one or more other governmental units. All such joint purchases shall be by competitive bids as provided in Section 4 of this Act. (Source: P.A. 87-960.)

Since 2007, the SPC Program is centrally operated by the Northwest Municipal Conference with shared program oversight by the SPC Governing Board and SPC Technical Review Committee.



A Joint Purchasing Program For Local Government Agencies

September 8, 2015

Mr. Brian Kilduff
Fleet Manager
Roesch Ford
333 W. Grand Avenue
Bensenville, IL 60106

Dear Mr. Kilduff

This letter is to inform you that the Suburban Purchasing Cooperative's Governing Board has approved the award of SPC Contract #151 for the 2016 Ford Expedition XL 4 Door 4x4 Vehicle plus Option Packages and Other Options to Roesch Ford, Bensenville, IL, based on your response being found to be in compliance with all bid specification requirements.

With acceptance of this contract, Roesch Ford, Bensenville, IL agrees to all terms and conditions set forth in the specifications contained within the Request for Proposals to which you responded

Roesch Ford, Bensenville, IL will handle all billing. Each vehicle purchased will be assessed a \$100.00 administrative fee per vehicle which shall be paid directly by the vendor to the SPC on a quarterly basis.

The SPC looks forward to another productive year working with Roesch Ford, Bensenville, IL. Please sign and date this agreement below, retaining copies for your files and returning the original to my attention. The duration of the contract is September 8, 2015 through September 7, 2016. The SPC reserves the right to extend this contract for up to (3) three additional one-year terms upon mutual agreement of the both the vendor and the SPC on a negotiated basis.

Sincerely,

Ellen Dayan, CPPB
Program Manager for Purchasing
Northwest Municipal Conference

09/08/2015

Name: Ellen Dayan
Northwest Municipal Conference

Date

9-8-2015
Name: Brian Kilduff
Roesch Ford

Date

DuPage Mayors & Managers Conference
1220 Oak Brook Road
Oak Brook, IL 60523
Susette Quistell
Phone: (630) 571-0480
Fax: (630) 571-0484

Northwest Municipal Conference
1600 East Golf Rd., Suite 0700
Des Plaines, IL 60016
Ellen Dayan, CPPB
Phone: (847) 296-9280
Fax: (847) 296-9283

South Suburban Mayors And Managers Association
1904 West 174th Street
East Hazel Crest, IL 60429
Ed Paesel
Phone: (708) 206-1155
Fax: (708) 206-1133

Will County Governmental League
3180 Theodore Street, Suite 101
Joliet, IL 60435
Charlie Belom
Phone: (815) 799-3535
Fax: (815) 729-3536

2016 FORD EXPEDITION XL

4-DOOR 4X4

CONTRACT # 151



ROESCH FORD COMMERCIAL TRUCK CENTER

Brian Kilduff

briankilduff@roeschtrucks.com

630-279-6000 x2245

www.roeschford.com

**SUBURBAN PURCHASING COOPERATIVE
 CONTRACT # 151
 2016 FORD EXPEDITION XL 4-DOOR 4X4
 PRICING WORKSHEET**

DEALER AGREES TO FURNISH PRICE/TOTAL BID AS SPECIFIED WITH ALL STANDARD EQUIPMENT

2016 MY EXPEDITION XL 4-DOOR 4X4 - BASE VEHICLE (100A) \$32,050.00

EL SERIES \$4,550.00

EQUIPMENT GROUP OPTIONS

101A \$1,425.00

- ~ SYNC WITH MY FORD ENHANCED VOICE RECOGNITION COMMUNICATION AND ENTERTAINMENT SYSTEM
- ~ SIRIUS XM SATELLITE RADIO (NOT AVAILABLE IN ALASKA OR HAWAII)
- ~ AM/FM SINGLE-CD/SINGLE 4.2" (INSTRUMENT CLUSTER / 4.2" CENTER STACK W/REAR VIEW CAMERA
- ~ SINGLE-ZONE ELECTRONIC AIR TEMPERATURE CONTROL (EATC) W/REAR AUX CONTROL
- ~ COMPASS
- ~ SELECT SHIFT AUTOMATIC TRANSMISSION WITH PROGRESSIVE RANGE SELECT
- ~ SEATS, 3rd ROW 60/40 MANUAL BENCH, CLOTH

102A ~\$1,425.00

- ~ 17" STEEL WHEEL (265/70R17 AT OWL)
- ~ CLOTH 1st ROW / VINYL 2nd ROW SEATING
- ~ 3rd ROW SEATING DELETE WITH COVER/END CAP
- ~ COLUMN SHIFTER AND FLOOR CONSOLE DELETE
- ~ DOOR HANDLES MOLD-IN-COLOR, BLACK GRILLE, 4X4 SKID PLATES
- ~ VINYL FLOOR COVERINGS
- ~ 3.73 REAR-AXLE, LIMITED-SLIP
- ~ LESS RUNNING BOARDS
- ~ 4X4 SKID PLATES (FRONT, TRANSFER CASE AND FUEL TANK)
- ~ FRONT TOW HOOKS
- ~ 3rd ROW STORAGE BINS

OPTIONS - POWERTRAIN

ENGINE 3.5L V6 ECOBOOST STANDARD \$0.00

3.5L V6 ECOBOOST SPEED AUTOMATIC W/OO STD

3.73 REAR-AXLE, LIMITED SLIP (ALL NON EL & 4X2 EL) \$272.00

AVAILABLE EXTERIOR OPTIONS

336 HEAVY-DUTY TRAILER TOW PACKAGE \$489.00

- ~ CLASS IV TRALER HITCH RECEIVER
- ~ WIRING HARNESS W/4 & 7 PIN CONNECTION
- ~ HEAVY-DUTY AUXILIARY TRANSMISSION OIL COOLER
- ~ HEAVY-DUTY RADIATOR
- ~ ELECTRONIC BRAKING WIRING KIT
- ~ INTEGRATED TRAILER BRAKE CONTROLLER

WHEELS 17" PAINTED ALUMINUM STANDARD \$0.00

RUNNING BOARDS \$625.00

41K 4X4 SKID PLATES (FRONT, TRANSFER CASE AND FUEL TANK) \$87.00

PACKAGE OPTIONS

50F FLEET CONVENIENCE PACKAGE \$345.00

STANDARD EQUIPMENT**MECHANICAL**

- Axle
 - Non-Limited-slip 3.15 (4x2 Non EL)
 - Non-Limited-slip 3.31 (4x4 Non EL & 4x2 EL)
 - Limited-slip 3.73 (4x4 EL)
- Brakes – 4-Wheel Disc (ABS)
- Engine – 3.5L V6 EcoBoost®
- Steering – Electric Power-Assist Steering (EPAS)
- Suspension – Multilink Independent Rear
- Transmission – 6-Speed Auto w/SelectShift®

SAFETY/SECURITY

- AdvanceTrac® w/RSC® (Roll Stability Control™)
- Airbags
 - Safety Canopy® (Incl. 3rd Row)
 - Side-Impact
- Child-Safety Locks – Rear
- Keyless-Entry
 - Remote
 - SecurCode™ (Keypad)
- LATCH (Lower Anchors & Tethers for Children) system
- Lighting – Illuminated Entry w/Approach Lamps
- Perimeter Alarm
- Seat belt pre-tensioners, Load limiting retractors, dual-stage front airbags, driver seat position sensing & crash severity sensing
- Security – SecurLock® Passive Anti-Theft System (PATS)
- SOS Post-Crash Alert System™
- Tire Pressure Monitoring System (TPMS)
- Traction Control (Brake Assist & Engine Braking)

EXTERIOR

- Bumpers – Mold-In-Color, Black
- Door Handles – MIC Black
- Exhaust – Single, Chrome-Tipped
- Glass – Solar-Tinted Front/Rear Privacy Glass
- Grille – Chrome Outer / MIC Black Inner (Black Outer SSV Pkg.)
- Headlamps – Quad Beam Reflector w/Blackout Treatment
- Lighting – Halogen (Round) Fog Lamps
- Mirrors
 - MIC Black, Power, Heated
 - Fuddle Lamps
- Roof Rack – Black Side Rails w/Black Crossbars
- Running Boards – Platform – Black (Opt. with SSV Pkg.)
- Skid Plate (4x2 – Front Skid Plate)
- Trim – Mold-In-Color, Black
- Wheels/Tires – 17" Aluminum Wheels (265/70R17 AT OWL)

INTERIOR/COMFORT

- Center Console – Large Floor Storage, Transmission Shifter, Coin Holder, (2) Headphone Jacks and Pen/Pencil Holder
- Climate Control – Manual w/Rear Auxiliary Controls
- Coat Hooks – (2) 2nd Row, (2) 3rd Row
- Cupholders – (4) 1st Row, (2) 2nd Row, (3) 3rd Row
- Door-Locks – Power w/AutoLock
- Floor Mats – 1st and 2nd Row
- Grab Handles – 1st Row, 2nd Row and Luggage

INTERIOR/COMFORT (continued)

- Lighting
 - Delayed Accessory Lighting
 - Dome Lamp – 1st Row and Cargo
 - Illuminated Door-Switches
 - Reading Lamps – 1st Row
- Overhead Console w/Sunglass Holder and Conversation Mirror
- Rear Cargo Area – Cargo Management System (EL Only)
- Rearview Mirror – Electrochromic w/Display screen
- Seats
 - Cloth
 - 1st Row – 8-way Power Driver's Bucket Seat with Manual Recline and Manual Lumbar
 - 1st Row – Manual Passenger Bucket Seat (2-Way)
 - 2nd Row – 40/20/40 (CenterSlide®) w/Recline
 - 3rd Row – Fold-Flat 60/40 (EL)
- Steering Wheel
 - Leather
 - Manual tilt/telescoping
- Storage
 - 3rd Row Bins (Non EL)
 - Glove Box
- Sun visors w/Dual Illuminated Mirrors
- Windows – Power – Driver 1-Touch Up/Down

FUNCTIONAL

- Audio
 - AM/FM Single-disc CD/MP3 player
 - 6 Speakers
 - Input Jack
- Cruise Control
- Easy Fuel® (Capless Refueling)
- Headlamps
 - AutoLamp¹
 - Rain lamps
- Hill Descent Control™ (4x4 Only)
- Hill Start Assist
- Instrument Cluster
 - Message Center
 - Tachometer
 - Trip Odometer
 - Outside Temperature Display
- MyKey®²
- Neutral Tow w/Front Tow Hooks – (4x4 only)
- Powerpoints – (1) 1st Row (1) 2nd Row Center Console (1) Cargo Area
- Rearview Camera
- Trailer Sway Control
- Trailer Tow – Integrated Class IV w/4-pin connector
- Windows – Rear Defroster
- Windshield Wipers – Intermittent Front & Rear

¹ Autolamp feature not offered on XL 100A & 102A Series² MyKey® feature for 100A & 102A only offers speed restriction option

AVAILABLE DEALER INSTALLED OPTIONS		
<input checked="" type="checkbox"/>		6" UNITY SPOT LIGHT \$525.00
<input checked="" type="checkbox"/>	153	LICENSE PLATE BRACKET \$0.00
<input checked="" type="checkbox"/>	43D	DAYTIME RUNNING LIGHTS \$39.00
<input checked="" type="checkbox"/>	42H	ENGINE BLOCK HEATER \$30.00
<input checked="" type="checkbox"/>		RUST PROOFING \$275.00
<input checked="" type="checkbox"/>		2016 SERVICE MANUAL ON CD FOR WINDOWS \$275.00
<input checked="" type="checkbox"/>		TRANSFER PLATES \$120.00
<input checked="" type="checkbox"/>		UNDERCOATING \$275.00
<input checked="" type="checkbox"/>		LICENSE AND TITLE "M" PLATES (NEW) \$105.00

INTERIOR SEAT OPTIONS		
<input checked="" type="checkbox"/>	87S	3RD ROW 60/40 MANUAL BENCH, CLOTH \$765.00
<input checked="" type="checkbox"/>		FRONT BUCKET SEATS W/ 40/20/40 SPLIT 2nd ROW SEAT (5 PASS) \$0.00
<input checked="" type="checkbox"/>		- EBONY/DUNE STANDARD
<input checked="" type="checkbox"/>		ACCENT COLOR MOLDED IN COLOR BLACK STANDARD \$0.00
<input checked="" type="checkbox"/>	51R	ALL WEATHER FLOOR MATS (RPO) \$65.00

EXTERIOR PAINT COLORS		
<input checked="" type="checkbox"/>	G1	SHADOW BLACK \$0.00
<input checked="" type="checkbox"/>	H7	BRONZE FIRE \$0.00
<input checked="" type="checkbox"/>	J7	MAGNETIC \$0.00
<input checked="" type="checkbox"/>	JV	GREEN GEM \$0.00
<input checked="" type="checkbox"/>	N1	BLUE JEANS \$0.00
<input checked="" type="checkbox"/>	PQ	RACE RED \$0.00
<input checked="" type="checkbox"/>	RR	RUBY RED METALLIC TINTED CLEAR COAT \$0.00
<input checked="" type="checkbox"/>	UX	INGOT SILVER \$345.00
<input checked="" type="checkbox"/>	Z1	OXFORD WHITE \$0.00

OPTIONS - WARRANTY		
<input checked="" type="checkbox"/>		6 YEAR 100,000 - PREMIUMCARE \$2,595.00
<input checked="" type="checkbox"/>		6 YEAR 75,000 - POWERTRAIN \$1,695.00

DELIVERY		
<input checked="" type="checkbox"/>		WITHIN 50 MILES OF DEALERSHIP \$0.00
<input checked="" type="checkbox"/>		GREATER THAN 50 MILES OF DEALERSHIP \$100.00

VEHICLE TOTAL PRICE \$ _____

QUANTITY _____

ORDER TOTAL \$ _____

0* *
 32,059* +
 279* +
 489* +
 625* +
 87* +
 345* +
 325* +
 39* +
 30* +
 275* +
 275* +
 275* +
 105* +
 36* +

014
 35,474* ◊

RESOLUTION NO. _____

A RESOLUTION AUTHORIZING THE MAYOR AND CITY CLERK TO ACCEPT A PROPOSAL FOR THE PURCHASE OF ONE NEW 2016 FORD EXPEDITION CARRYALL UNIT FROM ROESCH FORD IN AN AMOUNT NOT TO EXCEED \$35,474

BE IT RESOLVED BY THE CITY COUNCIL OF THE CITY OF DARIEN, DU PAGE COUNTY, ILLINOIS, as follows:

SECTION 1: The City Council of the City of Darien hereby authorizes the Mayor and City Clerk to accept a proposal for the purchase of one new 2016 Ford Expedition Carryall Unit from Roesch Ford in an amount not to exceed \$35,474 a copy of which is attached hereto as "**Exhibit A**".

SECTION 2: This Resolution shall be in full force and effect from and after its passage and approval as provided by law.

PASSED BY THE CITY COUNCIL OF THE CITY OF DARIEN, DU PAGE COUNTY, ILLINOIS, this 2nd day of May, 2016.

AYES: _____

NAYS: _____

ABSENT: _____

APPROVED BY THE MAYOR OF THE CITY OF DARIEN, DU PAGE COUNTY, ILLINOIS, this 2nd day of May, 2016.

KATHLEEN MOESLE WEAVER, MAYOR

ATTEST:

JOANNE E. RAGONA, CITY CLERK

APPROVED AS TO FORM

CITY ATTORNEY

2016 FORD EXPEDITION XL

4-DOOR 4X4

CONTRACT # 151

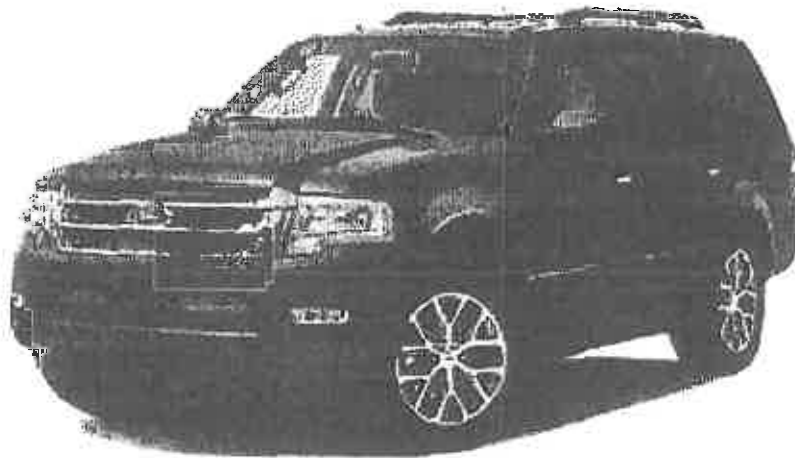

ROESCH FORD COMMERCIAL TRUCK CENTER

Brian Kilduff

briankilduff@roeschtrucks.com

630-279-6000 x2245

www.roeschford.com

**SUBURBAN PURCHASING COOPERATIVE
 CONTRACT # 151
 2016 FORD EXPEDITION XL 4-DOOR 4X4
 PRICING WORKSHEET**

DEALER AGREES TO FURNISH PRICE/TOTAL BID AS SPECIFIED WITH ALL STANDARD EQUIPMENT

2016 MY EXPEDITION XL 4-DOOR 4X4 - BASE VEHICLE (100A) \$32,059.00



EL SERIES \$4,550.00



EQUIPMENT GROUP OPTIONS



101A	<ul style="list-style-type: none"> ~ SYNC WITH MY FORD ENHANCED VOICE RECOGNITION COMMUNICATION AND ENTERTAINMENT SYSTEM ~ SIRIUS XM SATELLITE RADIO (NOT AVAILABLE IN ALASKA OR HAWAII) ~ AM/FM SINGLE-CD/SINGLE 4.2" INSTRUMENT CLUSTER / 4.2" CENTER STACK W/REAR VIEW CAMERA ~ SINGLE-ZONE ELECTRONIC AIR TEMPERATURE CONTROL (EATC) W/REAR AUX CONTROL ~ COMPASS ~ SELECT SHIFT AUTOMATIC TRANSMISSION WITH PROGRESSIVE RANGE SELECT ~ SEATS, 3rd ROW 60/40 MANUAL BENCH, CLOTH 	\$1,425.00
102A	<ul style="list-style-type: none"> SSV PACKAGE ~ 17" STEEL WHEEL (265/70R17 AT OWL) ~ CLOTH 1st ROW / VINYL 2nd ROW SEATING ~ 3rd ROW SEATING DELETE WITH COVER/END CAP ~ COLUMN SHIFTER AND FLOOR CONSOLE DELETE ~ DOOR HANDLES MOLD-IN-COLOR, BLACK GRILLE, 4X4 SKID PLATES ~ VINYL FLOOR COVERING ~ 3.73 REAR-AXLE, LIMITED-SLIP ~ LESS RUNNING BOARDS ~ 4X4 SKID PLATES (FRONT, TRANSFER CASE AND FUEL TANK) ~ FRONT TOW HOOKS ~ 3rd ROW STORAGE BINS 	~\$1,425.00



OPTIONS - POWERTRAIN		
	ENGINE 3.5L V6 ECOBOOST STANDARD	\$0.00
	3.5L V6 ECOBOOST SPEED AUTOMATIC W/O	STD
201	3.73 REAR-AXLE, LIMITED SLIP (ALL NON EL & 4X2 RL)	\$270.00



AVAILABLE EXTERIOR OPTIONS		
338	HEAVY-DUTY TRAILER TOW PACKAGE	\$489.00
	<ul style="list-style-type: none"> ~ CLASS IV TRALER HITCH RECEIVER ~ WIRING HARNESS W/4 & 7 PIN CONNECTION ~ HEAVY-DUTY AUXILIARY TRANSMISSION OIL COOLER ~ HEAVY-DUTY RADIATOR ~ ELECTRONIC BRAKING WIRING KIT ~ INTEGRATED TRAILER BRAKE CONTROLLER 	
	WHEELS 17" PAINTED ALUMINUM STANDARD	\$0.00
	RUNNING BOARDS	\$625.00
41K	4X4 SKID PLATES (FRONT, TRANSFER CASE AND FUEL TANK)	\$87.00



PACKAGE OPTIONS		
50F	FLEET CONVENIENCE PACKAGE	\$345.00

STANDARD EQUIPMENT

MECHANICAL

- Axle
 - Non-Limited-slip 3.15 (4x2 Non EL)
 - Non-Limited-slip 3.91 (4x4 Non EL & 4x2 EL)
 - Limited-slip 3.73 (4x4 EL)
- Brakes – 4-Wheel Disc (ABS)
- Engine – 3.5L V6 EcoBoost®
- Steering – Electric Power-Assist Steering (EPAS)
- Suspension – Multilink Independent Rear
- Transmission – 6-Speed Auto w/SelectShift®

SAFETY/SECURITY

- AdvanceTrac® w/RSC® (Roll Stability Control™)
- Airbags
 - Safety Canopy® (Incl. 3rd Row)
 - Side-Impact
- Child-Safety Locks – Rear
- Keyless-Entry
 - Remote
 - SecurCode™ (Keypad)
- LATCH (Lower Anchors & Tethers for Children) system
- Lighting – Illuminated Entry w/Approach Lamps
- Perimeter Alarm
- Seat belt pre-tensioners, Load limiting retractors, dual-stage front airbags, driver seat position sensing & crash severity sensing
- Security – SecurLock® Passive Anti-Theft System (PATS)
- SOS Post-Crash Alert System™
- Tire Pressure Monitoring System (TPMS)
- Traction Control (Brake Assist & Engine Braking)

EXTERIOR

- Bumpers – Mold-In-Color, Black
- Door Handles – MIC Black
- Exhaust – Single, Chrome-Tipped
- Glass – Solar-Tinted Front/Rear Privacy Glass
- Grille – Chrome Outer / MIC Black Inner (Black Outer SSV Pkg.)
- Headlamps – Quad Beam Reflector w/Blackout Treatment
- Lighting – Halogen (Round) Fog Lamps
- Mirrors
 - MIC Black, Power, Heated
 - Puddle Lamps
- Roof Rack – Black Side Rails w/Black Crossbars
- Running Boards – Platform – Black (Opt. with SSV Pkg.)
- Skid Plate (4x2 – Front Skid Plate)
- Trim – Mold-In-Color, Black
- Wheels/Tires – 17" Aluminum Wheels (265/70R17 AT OWL)

INTERIOR/COMFORT

- Center Console – Large Floor Storage, Transmission Shifter, Coin Holder, (2) Headphone Jacks and Pen/Pencil Holder
- Climate Control – Manual w/Rear Auxiliary Controls
- Coat Hooks – (2) 2nd Row, (2) 3rd Row
- Cupholders – (4) 1st Row, (2) 2nd Row, (3) 3rd Row
- Door-Locks – Power w/AutoLock
- Floor Mats – 1st and 2nd Row
- Grab Handles – 1st Row, 2nd Row and Liftgate

INTERIOR/COMFORT (continued)

- Lighting
 - Delayed Accessory Lighting
 - Dome Lamp – 1st Row and Cargo
 - Illuminated Door-Switches
 - Reading Lamps – 1st Row
- Overhead Console w/Sunglass Holder and Conversation Mirror
- Rear Cargo Area – Cargo Management System (EL Only)
- Rearview Mirror – Electrochromic w/Display screen
- Seats
 - Cloth
 - 1st Row – 6-way Power Driver's Bucket Seat with Manual Recline and Manual Lumbar
 - 1st Row – Manual Passenger Bucket Seat (2-Way)
 - 2nd Row – 40/20/40 (CenterSide®) w/Recline
 - 3rd Row – Fold-Flat 60/40 (EL)
- Steering Wheel
 - Leather
 - Manual tilt/telescoping
- Storage
 - 3rd Row Bins (Non EL)
 - Glove Box
- Sun visors w/Dual Illuminated Mirrors
- Windows – Power – Driver 1-Touch Up/Down

FUNCTIONAL

- Audio
 - AM/FM Single-disc CD/MP3 player
 - 6 Speakers
 - Input Jack
- Cruise Control
- Easy Fuel® (Capless Refueling)
- Headlamps
 - AutoLamp¹
 - Rain lamps
- Hill Descent Control™ (4x4 Only)
- Hill Start Assist
- Instrument Cluster
 - Message Center
 - Tachometer
 - Trip Odometer
 - Outside Temperature Display
- MyKey®²
- Neutral Tow w/Front Tow Hooks – (4x4 only)
- Powerpoints – (1) 1st Row (1) 2nd Row Center Console (1) Cargo Area
- Rearview Camera
- Trailer Sway Control
- Trailer Tow – Integrated Class IV w/4-pin connector
- Windows – Rear Defroster
- Windshield Wipers – Intermittent Front & Rear

¹ Autolamp feature not offered on XL 100A & 102A Series

² MyKey® feature for 100A & 102A only offers speed restriction option

AVAILABLE DEALER INSTALLED OPTIONS		
<input checked="" type="checkbox"/>		6" UNITY SPOT LIGHT \$525.00
<input checked="" type="checkbox"/>	253	LICENSE PLATE BRACKET \$0.00
<input checked="" type="checkbox"/>	43D	DAYTIME RUNNING LIGHTS \$39.00
<input checked="" type="checkbox"/>	41H	ENGINE BLOCK HEATER \$30.00
<input checked="" type="checkbox"/>		RUST PROOFING \$275.00
<input checked="" type="checkbox"/>		2016 SERVICE MANUAL ON CD FOR WINDOWS \$275.00
<input checked="" type="checkbox"/>		TRANSFER PLATES \$120.00
<input checked="" type="checkbox"/>		UNDERCOATING \$275.00
<input checked="" type="checkbox"/>		LICENSE AND TITLE "M" PLATES (NEW) \$105.00

INTERIOR SEAT OPTIONS		
<input checked="" type="checkbox"/>	375	3RD ROW 60/40 MANUAL BENCH, CLOTH \$764.00
<input checked="" type="checkbox"/>		FRONT BUCKET SEATS W/ 40/20/40 SPLIT 2nd ROW SEAT (5 PASS) \$0.00
<input checked="" type="checkbox"/>		- EBONY/DUNE STANDARD
<input checked="" type="checkbox"/>		ACCENT COLOR MOLDED IN COLOR BLACK STANDARD \$0.00
<input checked="" type="checkbox"/>	53R	ALL WEATHER FLOOR MATS (RPO) \$68.00

EXTERIOR PAINT COLORS		
<input checked="" type="checkbox"/>	G1	SHADOW BLACK \$0.00
<input checked="" type="checkbox"/>	H7	BRONZE FIRE \$0.00
<input checked="" type="checkbox"/>	J7	MAGNETIC \$0.00
<input checked="" type="checkbox"/>	JW	GREEN GEM \$0.00
<input checked="" type="checkbox"/>	N1	BLUE JEANS \$0.00
<input checked="" type="checkbox"/>	PQ	RACE RED \$0.00
<input checked="" type="checkbox"/>	RR	RUBY RED METALLIC TINTED CLEAR COAT \$345.00
<input checked="" type="checkbox"/>	UX	INGOT SILVER \$0.00
<input checked="" type="checkbox"/>	Z1	OXFORD WHITE \$0.00

OPTIONS - WARRANTY		
<input checked="" type="checkbox"/>		6 YEAR 100,000 - PREMIUMCARE \$2,595.00
<input checked="" type="checkbox"/>		6 YEAR 75,000 - POWERTRAIN \$1,695.00

DELIVERY		
<input checked="" type="checkbox"/>		WITHIN 50 MILES OF DEALERSHIP \$0.00
<input checked="" type="checkbox"/>		GREATER THAN 50 MILES OF DEALERSHIP \$100.00

VEHICLE TOTAL PRICE \$ _____

QUANTITY _____

ORDER TOTAL \$ _____

0 *
 32,059° +
 279° +
 489° +
 625° +
 87° +
 345° +
 325° +
 39° +
 30° +
 275° +
 275° +
 275° +
 105° +
 36° +

014
 35,474° ♦

AGENDA MEMO
Municipal Services Committee
April 25, 2016

Issue Statement

Approval of a resolution authorizing the purchase of one New Holland Workmaster 37 Tractor from Martin Implements in an amount not to exceed \$17,676 and a Land Pride 16 Series Grooming Mower attachment from Land Pride, in an amount not to exceed of \$2,473.50.

Background/History

The proposed tractor and mowing deck would be replacing Unit 201, 1990, Ford Model 1920 mowing tractor. The mower is a work horse for City's mowing operations of right of ways and detention facilities. The tractor is a 1990 model with approximately 3,370 hours and a rating of 74.93. The tractor continues to experience mechanical issues related with the starting equipment and motor. The mowing deck continues to be problematic with ongoing maintenance of the spindles and belts. Parts for the tractor are no longer being manufactured and aftermarket parts are difficult to find. Attached and labeled as Attachment A (7 pages) is the Rating Sheet and maintenance records. The existing machine will be declared as surplus and a separate agenda memo will be presented at a later date for City Council approval.

The proposed tractor is a New Holland Workmaster 37 and would be purchased through Martin Implements. The deck would be purchased from Land Pride and installation and setup would be completed through Martin Implements.

Staff has selected Martin Implements and Land Pride to supply the equipment and is the awarded vendor for the National Joint Purchasing Alliance-NJPA Contract Number 021815-CNH, and Contract Number 070313-LPI for equipment sales to municipalities nationally. Information regarding the National Joint Purchasing Alliance and the cost breakdown and specifications for the equipment are as follows:

1. New Holland tractor, through Martin Implements, attached and labeled as Attachment B, pages 1-8.
2. Land Pride 16 Series Grooming Mower, through Land Pride, attached and labeled as Attachment C, pages 1-4.

The proposed expenditure would be expended from the following line account:

ACCOUNT NUMBER	ACCOUNT DESCRIPTION	FY 16-17 BUDGET	PROPOSED EXPENDITURE	PROPOSED BALANCE
01-30-4815	EQUIPMENT MOWING TRACTOR UNIT 201	\$25,000	\$ 20,149.50	\$ 4,850.50

STAFF RECOMMENDATION

Staff recommends approval of the resolution authorizing the purchase of one of one New Holland Workmaster 37 Tractor from Martin Implements in an amount not to exceed \$17,676 and a Land Pride 16 Series Grooming Mower attachment from Land Pride, in an amount not to exceed of \$2,473.50.

ALTERNATE DECISION

As recommended by the Committee.

DECISION MODE

This item will be on the May 2, 2016 City Council agenda for formal consideration.

CRITERIA FOR REPLACING CITY VEHICLES AND EQUIPMENT				
UNIT NO	201	DEPARTMENT	Street	DATE
MODEL YEAR	1991	MODEL	1920	10-24-15
CURRENT MILEAGE		CURRENT HOURS	3348	
			MAXIMUM POINTS	VEHICLE SCORE
AGE				
	Department	Street		
	Life Expectancy	15		
	Age as of Report Date	24		
	AGE: Meets Requirements	Yes	20	20
USAGE				
	MILES			
	HOURS	3348		
	ATTACHMENT C OF THE VEHICLE REPLACEMENT POLICY			
	USAGE: Meets Requirements		20	8.93
TYPE OF SERVICE				
	1-LIGHT DUTY			
	15-CRITICAL DUTY			
	SERVICE: Meets Requirements		15	7
RELIABILITY				
	RELIABILITY: Frequency or Visits for Service			
	RELIABILITY: Meets Requirements		15	10
MAINTENANCE AND REPAIR COSTS				
	REPAIRS: Cost per Mile/Hours Exceeds Vehicle in Class			
	ORIGINAL PURCHASE PRICE	?		
	LIFE TO DATE REPAIR COST	9,037.47		
	PERCENTAGE OF REPAIRS TO PURCHASE PRICE	100%		

UNIT NO	201	DEPARTMENT	Street	DATE
MODEL YEAR	1991	MODEL	1920	10-24-15
CURRENT MILEAGE		CURRENT HOURS	3348	
			MAXIMUM POINTS	VEHICLE SCORE
PERCENTAGES OF REPAIR POINTS	POINTS			
1 THROUGH 20	2			
21 THROUGH 40	4			
41 THROUGH 60	6			
61 THROUGH 80	8			
81 THROUGH 100	10			
	REPAIRS: Meets Requirements		10	10
CONDITION				
	CONDITION OF ENGINE COMPONENTS (MAJOR REPAIRS NEEDED OR ANTICIPATED), BODY (BODY SHEET METAL RUSTED, STRUCTURAL COMPONENTS)			
	CONDITION: Meets Requirements		15	14
TECHNOLOGICAL ADVANCEMENTS	FUEL EMISSIONS, SAFETY FEATURES, ERGONOMICS		5	5
TOTAL POINTS			100	74.93

CITY OF DARIEN
 Repair Transaction Cost Detail

Equipment#	Repair Order#	Date	Meter(1)	Shop Loc/ Rep Class	Rep Reason/ Rep Site			
201	0000018633	05/26/94	545	01/01	08/01			
	<u>Group-System</u>			<u>Mech/Vendor</u>	<u>Work Acc</u>	<u>Part(\$)</u>	<u>Labor(\$)</u>	<u>Hours</u>
	01-PMA - PREV. MAINT.			002	A	35.97	15.00	1.00
201	0000018634	05/26/94	545	01/01	08/01			
	12-95 - FLAILS			002		33.80	30.00	2.00
201	0000018635	10/27/94	448	01/01	08/01			
	02-17 - TIRES,TUBES,ETC					189.80	0.00	0.00
201	0000018636	12/06/94	590	01/01	08/01			
	01-PMB - PREV. MAINT.			002	B	0.00	7.50	0.50
201	0000018637	03/15/95	710	01/01	08/02			
	01-PMB - PREV. MAINT.			002	B	0.00	7.50	0.50
201	0000018638	05/01/95	710	01/01	08/01			
	01-PMA - PREV. MAINT.			001	A	37.73	28.00	1.00
201	0000018639	06/27/95	746	01/03	01/01			
	09-59 - PTO			002		56.18	7.50	0.50
201	0000018640	11/06/95	715	01/01	08/01			
	01-PMB - PREV. MAINT.			002	B	0.00	7.50	0.50
201	0000018641	08/07/96	801	01/03	01/01			
	02-17 - TIRES,TUBES,ETC					22.40	0.00	0.00
201	0000018642	11/21/96	1004	01/01	08/01			
	01-PMA - PREV. MAINT.			001	A	33.41	14.00	0.50
201	0000018643	11/21/96	1004	01/01	08/01			
	01-PMB - PREV. MAINT.			001	B	0.00	14.00	0.50
201	0000018644	06/03/97	1043	01/01	08/01			
	01-PMB - PREV. MAINT.			002	B	0.00	7.50	0.50
201	0000018645	06/25/97	1066	01/03	01/01			
	06-35 - BATTERY					79.95	0.00	0.00
201	0000018646	07/30/97	1045	00/03	01/01			
	12-95 - FLAILS					299.20	0.00	0.00
201	0000018647	10/22/97	1124	01/01	08/01			
	01-PMA - PREV. MAINT.			001	A	36.68	0.00	1.00
201	0000018648	12/01/97	1128	01/01	08/01			
	01-PMA - PREV. MAINT.			001	A	0.00	14.00	0.50
201	0000018649	12/01/97	1128	01/01	08/01			
	01-PMB - PREV. MAINT.			001	B	0.00	14.00	0.50
201	0000018650	07/13/98	1237	01/01	08/01			
	01-PMB - PREV. MAINT.			001	B	0.00	14.00	0.50
201	0000018651	07/29/98	1257	01/02	04/01			
	11-87 - LAWN MOWERS			001		966.90	28.00	1.00
201	0000018652	11/05/98	1325	01/01	08/01			
	01-PMA - PREV. MAINT.			001	A	15.27	14.00	0.50
201	0000018653	11/12/98	1050	01/01	08/01			
	01-PMB - PREV. MAINT.			001	B	0.00	14.00	0.50
201	0000018654	04/22/99	1342	01/02	04/01			
	12-95 - FLAILS			001		8.00	14.00	0.50

CITY OF DARIEN
 Repair Transaction Cost Detail

Equipment#	Repair Order#	Date	Meter(1)	Shop Loc/ Rep Class	Rep Reason/ Rep Site			
201	0000018655	05/12/99	1365	00/01	08/01			
	<u>Group-System</u>			<u>Mech/Vendor</u>	<u>Work Acc</u>	<u>Part(\$)</u>	<u>Labor(\$)</u>	<u>Hours</u>
	12-95 - FLAILS			001		20.00	14.00	0.50
201	0000018658	06/15/99	1403	01/01	08/01			
	01-PMB - PREV. MAINT.			001	B	0.00	14.00	0.50
201	0000018657	07/01/99	1043	01/02	04/01			
	12-95 - FLAILS			001		30.00	14.00	0.50
201	0000018658	08/16/99	1458	01/01	08/01			
	12-95 - FLAILS			002		149.78	45.00	3.00
201	0000018659	11/09/99	1492	01/01	08/01			
	01-PMA - PREV. MAINT.			002	A	10.90	7.50	0.50
201	0000018660	12/13/99	1492	01/01	08/01			
	01-PMB - PREV. MAINT.			002	B	0.00	7.50	0.50
201	0000023701	03/15/00	1492	01/01	08/01			
	01-PMA - PREV. MAINT.			002		0.00	7.50	0.50
201	0000023711	03/15/00	1492	01/01	08/01			
	01-PMB - PREV. MAINT.			002		0.00	7.50	0.50
201	0000023765	04/18/00	1494	01/02	01/01			
	11-87 - LAWN MOWERS			001		83.28	84.00	3.00
201	0000023861	08/01/00	1620	01/01	01/01			
	11-87 - LAWN MOWERS			001		643.58	196.00	7.00
201	0000023894	08/28/00	1645	01/02	04/01			
	02-17 - TIRES,TUBES,ETC			002		193.78	30.00	2.00
	05-24 - DRIVE SHAFT			002		16.35	7.50	0.50
201	0000023948	10/23/00	1690	01/01	08/01			
	01-PMA - PREV. MAINT.			001		14.96	28.00	1.00
	01-PMB - PREV. MAINT.			001		0.00	14.00	0.50
201	0000024085	02/07/01	1690	/01	08/01			
	01-PMB - PREV. MAINT.			002		0.00	7.50	0.50
201	0000024169	04/27/01	1992	/02	04/01			
	06-35 - BATTERY			001		82.00	28.00	1.00
201	0000024175	05/04/01	1992	/01	08/01			
	01-PMA - PREV. MAINT.			001		12.40	28.00	1.00
201	0000024228	06/17/01	1992	/03	01/01			
	09-57 - HYDRAULIC SYS			001		47.05	28.00	1.00
201	0000024265	07/16/01	1992	/02	01/01			
	11-87 - LAWN MOWERS			001		138.41	28.00	1.00
	03-07 - INTERIOR			001		90.47	14.00	0.50
201	0000024347	10/05/01	1992	/01	08/01			
	01-PMB - PREV. MAINT.					0.00	28.00	1.00
201	0000024561	04/02/02	1992	/01	08/01			
	01-PMB - PREV. MAINT.			002		0.00	7.50	0.50
201	0000024756	09/10/02	1992	/02	01/01			
	11-87 - LAWN MOWERS			001		271.48	28.00	1.00
201	0000024757	09/09/02	1992	/03	01/01			
	02-17 - TIRES,TUBES,ETC			001		20.40	14.00	0.50

CITY OF DARIEN
 Repair Transaction Cost Detail

Equipment#	Repair Order#	Date	Meter(1)	Shop Loc/ Rep Class	Rep Reason/ Rep Site			
201	0000024792	10/15/02	2006	/01	08/01			
	<u>Group-System</u>			<u>Mech/Vendor</u>	<u>Work Acc</u>	<u>Part(\$)</u>	<u>Labor(\$)</u>	<u>Hours</u>
	01-PMA - PREV. MAINT.			001		70.74	28.00	1.00
	01-PMB - PREV. MAINT.			001		0.00	14.00	0.50
201	0000025088	05/19/03	2016	/01	08/01			
	01-PMB - PREV. MAINT.			001		0.00	28.00	1.00
201	0000025290	11/12/03	2150	/01	08/01			
	01-PMA - PREV. MAINT.			002		14.88	7.50	0.50
	01-PMB - PREV. MAINT.			002		0.00	7.50	0.50
201	0000025306	12/01/03	2150	/01	08/01			
	11-87 - LAWN MOWERS			001		78.98	28.00	1.00
201	0000025479	05/05/04	2195	/01	08/01			
	01-PMB - PREV. MAINT.			001		0.00	14.00	0.50
	09-57 - HYDRAULIC SYS			001		60.53	28.00	1.00
201	0000025495	05/19/04	2195	/01	08/01			
	01-PMB - PREV. MAINT.			001		0.00	14.00	0.50
201	0000025573	07/27/04	2195	01/01	02/01			
	11-87 - LAWN MOWERS					115.22	0.00	0.00
201	0000025598	06/06/04	2312	01/02	04/01			
	04-13 - BRAKES			001		652.24	84.00	3.00
201	0000025707	11/02/04	2312	01/01	08/01			
	01-PMA - PREV. MAINT.			001		18.95	28.00	1.00
	01-PMB - PREV. MAINT.			001		0.00	28.00	1.00
201	0000025928	05/09/05	2333	/01	08/01			
	01-PMB - PREV. MAINT.			001		0.00	14.00	0.50
201	0000025973	06/24/05	2444	/01	08/01			
	02-17 - TIRES,TUBES,ETC			002		101.43	15.00	1.00
201	0000025982	07/08/05	2450	/02	04/01			
	02-19 - WHEELS/RIMS			002		329.46	15.00	1.00
	08-33 - IGNITION SYS			002		63.13	15.00	1.00
201	0000026096	10/04/05	2450	/02	01/01			
	06-35 - BATTERY			001		62.20	28.00	1.00
201	0000026231	12/29/05	2460	/01	08/01			
	01-PMB - PREV. MAINT.			001		0.00	14.00	0.50
201	0000026475	05/18/06	2428	/02	04/01			
	11-87 - LAWN MOWERS			001		0.00	56.00	2.00
201	0000026575	06/22/06	2468	/01	08/01			
	02-17 - TIRES,TUBES,ETC			002		244.00	7.50	0.50
201	0000026597	07/21/06	2468	/01	08/01			
	01-PMA - PREV. MAINT.			002		15.65	7.50	0.50
201	0000026622	08/01/06	2468	/01	08/01			
	01-PMB - PREV. MAINT.			001		0.00	14.00	0.50
201	0000027056	11/06/06	2507	/01	08/01			
	01-PMA - PREV. MAINT.			002		18.64	7.50	0.50
201	0000027175	02/28/07	2507	/01	08/01			
	01-PMB - PREV. MAINT.			001		0.00	14.00	0.50

CITY OF DARIEN
 Repair Transaction Cost Detail

Equipment#	Repair Order#	Date	Meter(1)	Shop Loc/ Rep Class	Rep Reason/ Rep Site			
201	0000027290	05/08/07	2545	/01	08/01			
	<u>Group-System</u>			<u>Mech/Vendor</u>	<u>Work Acc</u>	<u>Part(\$)</u>	<u>Labor(\$)</u>	<u>Hours</u>
	09-57 - HYDRAULIC SYS			001		1,310.01	196.00	7.00
	01-PMB - PREV. MAINT.			001		68.26	28.00	1.00
201	0000027536	11/16/07	2596	/01	08/01			
	01-PMB - PREV. MAINT.			001		0.00	28.00	1.00
	06-34 - LIGHTING SYS			001		0.00	15.40	0.55
201	0000027815	04/14/08	2596	/01	08/01			
	01-PMB - PREV. MAINT.			002		0.00	7.50	0.50
201	0000027952	06/27/08	2596	/01	08/01			
	11-87 - LAWN MOWERS			001		85.00	56.00	2.00
201	0000028068	09/30/08	2764	/01	08/01			
	05-21 - AXEL FRONT			001		207.50	140.00	5.00
201	0000028134	11/14/08	2771	/01	08/01			
	01-PMA - PREV. MAINT.			002		18.54	15.00	1.00
	01-PMB - PREV. MAINT.			002		0.00	7.50	0.50
201	0000028426	07/02/09	2771	/01	08/01			
	01-PMB - PREV. MAINT.			002		0.00	7.50	0.50
201	0000028632	12/01/09	2830	01/01	08/01			
	01-PMA - PREV. MAINT.			002		7.68	45.00	3.00
	01-PMA - PREV. MAINT.			002		10.86	0.00	0.00
	07-41 - AIR INTAKE SYS			002		34.77	0.00	0.00
	07-44 - FUEL SYS			002		7.80	0.00	0.00
	09-57 - HYDRAULIC SYS			002		55.04	0.00	0.00
201	0000028705	02/03/10	2930	01/01	08/01			
	01-PMB - PREV. MAINT.			002		0.00	7.50	0.50
201	0000028843	05/19/10	2849	01/02	01/01			
	11-87 - LAWN MOWERS			002		24.50	22.50	1.50
201	0000028874	06/18/10	2884	01/02	01/01			
	11-87 - LAWN MOWERS			002		110.00	15.00	1.00
201	0000028879	06/22/10	2887	01/02	01/01			
	11-87 - LAWN MOWERS			002		0.00	7.50	0.50
201	0000028968	09/14/10	2968	01/01	08/01			
	01-PMB - PREV. MAINT.			002		0.00	15.00	1.00
	01-PMC - PREV. MAINT.			002		0.00	15.00	1.00
201	0000029222	04/26/11	2969	01/01	08/01			
	01-PMB - PREV. MAINT.			001		0.00	28.00	1.00
201	0000029278	05/31/11	2987	01/02	01/01			
	06-35 - BATTERY			002		81.39	30.00	2.00
201	0000029321	07/07/11	3037	01/03	01/01			
	07-42 - COOLING SYS			002		0.00	7.50	0.50
201	0000029388	08/26/11	3038	01/01	08/01			
	01-PMA - PREV. MAINT.			002		23.61	15.00	1.00
	01-PMC - PREV. MAINT.			002		10.13	0.00	0.00
	07-41 - AIR INTAKE SYS			002		51.25	0.00	0.00
201	0000029485	11/22/11	3038	01/01	08/01			
	01-PMB - PREV. MAINT.			002		10.00	15.00	1.00

CITY OF DARIEN
 Repair Transaction Cost Detail

Equipment#	Repair Order#	Date	Meter(1)	Shop Loc/ Rep Class	Rep Reason/ Rep Site			
201	0000029755	06/01/12	3501	01/03	01/01			
	<u>Group-System</u>			<u>Mech/Vendor</u>	<u>Work Acc</u>	<u>Part(\$)</u>	<u>Labor(\$)</u>	<u>Hours</u>
	09-57 - HYDRAULIC SYS			002		48.11	45.00	3.00
	02-17 - TIRES,TUBES,ETC			002		336.80	15.00	1.00
201	0000029767	06/08/12	3612	01/01	08/01			
	01-PMB - PREV. MAINT.			002		80.45	30.00	2.00
201	0000029809	07/12/12	3116	01/01	08/01			
	01-PMA - PREV. MAINT.			002		28.62	18.75	1.25
	11-87 - LAWN MOWERS			002		30.84	7.50	0.50
201	0000030171	05/15/13	3176	01/01	08/01			
	01-PMB - PREV. MAINT.			002		0.00	3.75	0.25
	11-87 - LAWN MOWERS			002		112.40	30.00	2.00
201	0000030220	07/12/13	3257	01/03	01/01			
	09-57 - HYDRAULIC SYS			002		230.90	15.00	1.00
	11-87 - LAWN MOWERS			002		87.60	75.00	5.00
	04-11 - AXEL FRONT			002		31.98	60.00	4.00
201	0000030300	09/24/13	3269	01/03	01/01			
	11-87 - LAWN MOWERS			002		261.04	60.00	4.00
201	0000030584	07/15/14	3306	01/03	01/01			
	11-87 - LAWN MOWERS			002		7.80	15.00	1.00
201	0000030589	07/29/14	3316	01/03	01/01			
	07-46 - BELTS			002		100.00	30.00	2.00
201	0000030914	06/10/15	3334	01/03	01/01			
	11-87 - LAWN MOWERS			002		30.35	15.00	1.00
201	0000030927	06/19/15	3335	01/03	01/01			
	02-17 - TIRES,TUBES,ETC			002		642.43	15.00	1.00
201	0000030935	06/23/15	3348	01/01	08/01			
	01-PMA - PREV. MAINT.			002		20.85	15.00	1.00
	01-PMB - PREV. MAINT.			002		17.48	3.75	0.25
				Grand Total		<u>9,670.13</u>	<u>2,632.15</u>	<u>125.30</u>

Home > Cooperative Purchasing > Contracts - Fleet > Construction & Agricultural Equipment - New Holland Ag



New Holland Ag



Contract#: 021815-CNH
Category: Construction & Agricultural Equipment
Description: Ag Tractors & Implements
Maturity Date: 03/17/2019

Overview

[Contract Documentation](#)

[Pricing](#)

[Marketing Materials](#)

[NJPA Contact Information](#)

HOW TO PURCHASE

[Our step-by-step guide](#)

New Holland manufactures a wide range of equipment, including a full line of tractors; hay and forage equipment; and harvesting, crop production equipment. The New Holland Agricultural lines includes Agricultural and Compact Tractors, Attachments & Loaders, Planting and Seeding, Application, Harvest, and Hay & Forage Equipment, Spreaders, and Rustler Utility Vehicles.

[New Holland Ag Products](#)

[New Holland Ag Build & Price](#)

[New Holland Ag Find a Dealer](#)

Vendor Contact Info

Amy Swett
Direct Phone: 717-355-1686
amy.swett@newholland.com
www.newholland.com

Contract Award
RFP 021815 #

FORM D



Formal Offering of Proposal
(To be completed Only by Proposer)

AGRICULTURAL TRACTORS WITH RELATED EQUIPMENT AND ACCESSORIES

In compliance with the Request for Proposal (RFP) for AGRICULTURAL TRACTORS WITH RELATED EQUIPMENT AND ACCESSORIES the undersigned warrants that I/we have examined this RFP and, being familiar with all of the instructions, terms and conditions, general specifications, expectations, technical specifications, service expectations and any special terms, do hereby propose, fully commit and agree to furnish the defined equipment/products and related services in full compliance with all terms, conditions of this RFP, any applicable amendments of this RFP, and all Proposer's Response documentation. Proposer further understands they accept the full responsibility as the sole source of responsibility of the proposed response herein and that the performance of any sub-contractors employed by the Proposer in fulfillment of this proposal is the sole responsibility of the Proposer.

Company Name: CNH INDUSTRIAL AMERICA LLC Date: FEBRUARY 17, 2015

Company Address: 700 STATE STREET

City: RACINE State: WI Zip: 53404

Contact Person: PATRICIA PLADDIE Title: MANAGER, GOVERNMENT ACCOUNTS

Authorized Signature (ink only): *Patricia Pladdie* PATRICIA PLADDIE
(Name printed or typed)



Contract Acceptance and Award

(To be completed only by NJPA)

NJPA 021815 # AGRICULTURAL TRACTORS WITH RELATED EQUIPMENT AND ACCESSORIES

CNH Industrial America, LLC

Proposer's full legal name

Your proposal is hereby accepted and awarded. As an awarded Proposer, you are now bound to provide the defined product/equipment and services contained in your proposal offering according to all terms, conditions, and pricing set forth in this RFP, any amendments to this RFP, your Response, and any exceptions accepted or rejected by NJPA on Form C.

The effective start date of the Contract will be March 17th, 20 15 and continue for four years from the board award date. This contract has the consideration of a fifth year renewal option at the discretion of NJPA.

National Joint Powers Alliance® (NJPA)

NJPA Authorized signature:

[Handwritten signature]

NJPA Executive Director

Dr. Chad Corvette

(Name printed or typed)

Awarded this 17th day of March, 20 15 NJPA Contract Number 021815-CNH

NJPA Authorized signature:

[Handwritten signature]

NJPA Board Member

Scott Veronen

(Name printed or typed)

Executed this 17th day of March, 20 15 NJPA Contract Number 021815-CNH

Proposer hereby accepts contract award including all accepted exceptions and NJPA clarifications identified on FORM C.

Vendor Name CNH INDUSTRIAL AMERICA, LLC

Vendor Authorized signature:

[Handwritten signature]

PATRICIA LARDIE

(Name printed or typed)

Title: NATIONAL GOVERNMENT ACCOUNTS MANAGER

Executed this 7th day of APRIL, 20 15 NJPA Contract Number 021815-CNH



National Joint Powers Alliance
 Contract # 021815
 Effective 05/01/15 - 04/30/19
 New Holland Equipment
 For United States



Model	Tier	List Discount for Members	Price & Date Pages Dated	Model	Tier	List Discount for Members	Price & Date Pages Dated
BOOMER 24	4	28%	9/1/2015	T8.320	4B	35%	10/1/2015
BOOMER 33	4B	28%	9/1/2015	T8.350	4B	35%	10/1/2015
BOOMER 37	4B	28%	9/1/2015	T8.380	4B	35%	10/1/2015
BOOMER 41	4B	28%	9/1/2015	T8.410	4B	35%	10/1/2015
BOOMER 47	4B	28%	9/1/2015	T8.435	4B	35%	10/1/2015
BOOMER 46D	4B	28%	9/1/2015				
BOOMER 54D	4B	28%	9/1/2015	T9.435	4B	30%	10/1/2015
				T9.480	4B	30%	10/1/2015
Work Master 33	4B	28%	9/1/2015	T9.530	4B	30%	10/1/2015
Work Master 37	4B	28%	9/1/2015	T9.565	4B	30%	10/1/2015
Work Master 50	4B	25%	9/1/2015	T9.600	4B	30%	10/1/2015
Work Master 60	4B	25%	9/1/2015	T9.645	4B	30%	10/1/2015
Work Master 70	4B	25%	9/1/2015	T9.700	4B	30%	10/1/2015
				T9 Tracks		27%	10/1/2015
Powerstar T4.65	4B	30%	9/2/2015	RST120		14%	7/1/2015
Powerstar T4.75	4B	30%	9/2/2015	RST125		14%	7/1/2015
T4.90	4B	30%	9/2/2015	implements		25%	9/1/2015
T4.100	4B	30%	9/2/2015	805TL Loaders		25%	9/1/2015
T4.110	4B	30%	9/2/2015	600/605TL Loaders		25%	9/1/2015
T4.120	4B	30%	9/2/2015	Compact Loaders		25%	9/1/2015
T5.110	4B	30%	9/2/2015				
T5.120	4B	30%	9/2/2015	Crop Packaging		25%	9/2/2015
				Crop Preparation		25%	9/2/2015
TS6.110	4B	25%	9/2/2015				
TS6.120	4B	25%	9/2/2015				
TS6.130	4B	25%	9/2/2015	Self-Propelled		25%	9/1/2015
TS6.140	4B	25%	9/2/2015	Pull Type		25%	9/2/2015
T6.145	4B	30%	9/2/2015			25%	9/2/2015
T6.155	4B	30%	9/2/2015				
T6.165	4B	30%	9/2/2015			25%	10/1/2015
T6.175	4B	30%	9/2/2015				
T6.180	4B	30%	9/2/2015			25%	10/1/2015
T6.175	4B	30%	9/2/2015			25%	7/7/2015
T7.175 SWB	4B	32%	10/1/2015				
T7.190 SWB	4B	32%	10/1/2015				
T7.210 SWB	4B	32%	10/1/2015				
T7.230 LWB	4B	32%	10/1/2015	LM6.25		25%	9/1/2015
T7.245 LWB	4B	32%	10/1/2015	LM6.28		25%	9/1/2015
T7.260 LWB	4B	32%	10/1/2015	LM6.32		25%	9/1/2015
T7.278 LWB	4B	32%	10/1/2015	LM7.42		25%	9/1/2015
T7.290 HD CVT	4B	32%	10/1/2015	LM9.35		25%	9/1/2015
T7.315 HD CVT	4B	32%	10/1/2015			25%	7/7/2015



National Joint Powers Alliance
 Contract # 021815
 Effective 05/01/15 - 04/30/19
 New Holland Equipment
 For United States



Skid Steers United States			
L213	4F	24%	10/17/2014
L216	4F	24%	10/17/2014
L218	4F	26%	10/17/2014
L220	4F	25%	10/17/2014
L221	4F	25%	10/17/2014
L228	4F	26%	10/17/2014
L230	4F	32%	10/17/2014

These models are limited to Field Inventory

BOOMER 20	4A	28%	9/1/2013
BOOMER 25	4A	28%	9/1/2013
BOOMER 3040		28%	9/1/2014
BOOMER 3046		28%	9/1/2014
BOOMER 3060		28%	9/1/2014
BOOMER 30	4A	28%	9/1/2013
BOOMER 35	3	28%	9/1/2013
BOOMER 40		28%	9/1/2013
BOOMER 50		28%	9/1/2013

Work Master 35	3	28%	9/1/2014
Work Master 40	3	28%	9/1/2014
Work Master 45	4A	28%	9/1/2014
Work Master 55	4A	25%	9/1/2014
WorkMaster 65	3	25%	9/1/2014
WorkMaster 75	3	25%	9/1/2014

T4.85	4A	30%	9/1/2014
T4.95	4A	30%	9/1/2014
T4.105	4A	30%	9/1/2014
T4.115	4A	30%	9/1/2014

T6.95	4A	30%	9/1/2014
T5.106	4A	30%	9/1/2014
T5.115	4A	30%	9/1/2014

T6.140	4A	30%	9/1/2014
T6.150	4A	30%	9/1/2014
T6.160	4A	30%	9/1/2014
T6.155	4A	30%	9/1/2014
T6.165	4A	30%	9/1/2014
T6.175	4A	30%	9/1/2014

Order and add freight and not up to the purchase orders. These discounts CANNOT be used with other Writing

Compact Track Loaders United States			
C227	4F	26%	10/15/2014
C232	4F	26%	10/15/2014
C238	4F	26%	10/15/2014

These models are limited to Field Inventory

TS6.110	3	25%	4/23/2014
TS6.120	3	25%	4/23/2014
TS6.125	3	25%	4/23/2014
TS6.140	3	25%	4/23/2014
TS6.120 HC	3	25%	4/20/2014

T7.170 SWB	4	32%	9/1/2013
T7.185 SWB	4	32%	9/1/2013
T7.200 SWB	4	32%	9/1/2013
T7.210 SWB	4	32%	9/1/2013

T7.220 LWB	4	32%	9/1/2013
T7.235 LWB	4	32%	9/1/2013
T7.250 LWB	4	32%	9/1/2013
T7.260 LWB	4	32%	9/1/2013
T7.270 LWB	4	32%	9/1/2013

T8.275	4	35%	9/4/2013
T8.300	4	35%	9/4/2013
T8.330	4	35%	9/4/2013
T8.380	4	35%	9/4/2013
T8.390	4	35%	9/4/2013
T8.420	4	35%	9/4/2013

T9.390	4	30%	9/1/2013
T9.450	4	30%	9/1/2013
T9.505	4	30%	9/1/2013
T9.560	4	30%	9/1/2013
T9.615	4	30%	9/1/2013
T9.670	4	30%	9/1/2013

RST118		14%	9/1/2014
--------	--	-----	----------



National Joint Powers Alliance
 Contract # 021815
 Effective 05/01/15 - 04/30/19
 New Holland Equipment
 For Canada



Model	Tier	List Discount for Members	Price & Data Pages Dated
BOOMER 24	4	28%	9/1/2015
BOOMER 33	4B	28%	9/1/2015
BOOMER 37	4B	28%	9/1/2015
BOOMER 41	4B	28%	9/1/2015
BOOMER 47	4B	28%	9/1/2015
BOOMER 48D	4B	28%	9/1/2015
BOOMER 54D	4B	28%	9/1/2015
Work Master 33	4B	28%	9/1/2015
Work Master 37	4B	28%	9/1/2015
Work Master 50	4B	25%	9/1/2015
Work Master 60	4B	25%	9/1/2015
Work Master 70	4B	25%	9/1/2015
Powerstar T4.65	4B	30%	9/2/2015
Powerstar T4.75	4B	30%	9/2/2015
T4.90	4B	30%	9/2/2015
T4.100	4B	30%	9/2/2015
T4.110	4B	30%	9/2/2015
T4.120	4B	30%	9/2/2015
T5.110	4B	30%	9/2/2015
T5.120	4B	30%	9/2/2015
TS6.110	4B	25%	9/2/2015
TS6.120	4B	25%	9/2/2015
TS6.130	4B	25%	9/2/2015
TS6.140	4B	25%	9/2/2015
T6.145	4B	30%	9/2/2015
T6.155	4B	30%	9/2/2015
T6.165	4B	30%	9/2/2015
T6.175	4B	30%	9/2/2015
T6.180	4B	30%	9/2/2015
T6.175	4B	30%	9/2/2015
T7.175 SWB	4B	32%	10/2/2015
T7.190 SWB	4B	32%	10/2/2015
T7.210 SWB	4B	32%	10/2/2015
T7.230 LWB	4B	32%	10/2/2015
T7.245 LWB	4B	32%	10/2/2015
T7.260 LWB	4B	32%	10/2/2015
T7.270 LWB	4B	32%	10/2/2015
T7.290 HD CVT	4B	32%	10/2/2015
T7.315 HD CVT	4B	32%	10/2/2015

Model	Tier	List Discount for Members	Price & Data Pages Dated
T8.320	4B	35%	10/2/2015
T8.350	4B	35%	10/2/2015
T8.390	4B	35%	10/2/2015
T8.410	4B	35%	10/2/2015
T8.435	4B	35%	10/2/2015
T9.435	4B	30%	10/2/2015
T9.480	4B	30%	10/2/2015
T9.530	4B	30%	10/2/2015
T9.565	4B	30%	10/2/2015
T9.600	4B	30%	10/2/2015
T9.645	4B	30%	10/2/2015
T9.700	4B	30%	10/2/2015
T9 Tracks		27%	10/1/2015
RST120		14%	7/1/2015
RST125		14%	7/1/2015
Implements		25%	9/1/2015
305TL Loaders		25%	9/1/2015
600/605TL Loaders		25%	9/1/2015
Compact Loaders		25%	9/1/2015
Crop Packaging		25%	9/3/2015
Crop Preparation		25%	9/2/2015
Self-Propelled Pull Type		25%	9/3/2015
Self-Propelled		25%	9/2/2015
Self-Propelled		25%	9/3/2015
Self-Propelled		25%	8/10/2015
Self-Propelled		25%	8/10/2015
Self-Propelled		25%	8/10/2015
Self-Propelled		25%	8/10/2015
LM5.25		25%	9/1/2015
LM6.28		25%	9/1/2015
LM6.32		25%	9/1/2015
LM7.42		25%	9/1/2015
LMS.35		25%	9/1/2015
Self-Propelled		25%	8/10/2015



National Joint Powers Alliance
 Contract # 021815
 Effective 05/01/15 - 04/30/19
 New Holland Equipment
 For Canada



Skid Steers United States			
L213	4A	24%	8/10/2015
L215	4A	24%	8/10/2015
L218	4A	28%	8/10/2015
L220	4A	25%	8/10/2015
L221	4F	25%	8/10/2015
L223	4A	28%	8/10/2015
L225	4A	28%	8/10/2015
L230	4A	32%	8/10/2015
These models are limited to field inventory			
BOOMER 20	4A	28%	9/1/2013
BOOMER 25	4A	28%	9/1/2013
BOOMER 3040		28%	9/1/2014
BOOMER 3045		28%	9/1/2014
BOOMER 3050		28%	9/1/2014
BOOMER 30	4A	28%	9/1/2013
BOOMER 35	3	28%	9/1/2013
BOOMER 40		28%	9/1/2013
BOOMER 50		28%	9/1/2013
Work Master 35	3	28%	9/1/2014
Work Master 40	3	28%	9/1/2014
Work Master 45	4A	25%	9/1/2014
Work Master 55	4A	25%	9/1/2014
WorkMaster 65	3	25%	9/1/2014
WorkMaster 75	3	25%	9/1/2014
T4.85	4A	30%	9/1/2014
T4.95	4A	30%	9/1/2014
T4.105	4A	30%	9/1/2014
T4.115	4A	30%	9/1/2014
T5.95	4A	30%	9/1/2014
T5.105	4A	30%	9/1/2014
T5.115	4A	30%	9/1/2014
T6.140	4A	30%	9/1/2014
T6.150	4A	30%	9/1/2014
T6.160	4A	30%	9/1/2014
T6.165	4A	30%	9/1/2014
T6.165	4A	30%	9/1/2014
T6.175	4A	30%	9/1/2014
Dealer can add freight and set-up to the purchase orders. These discounts CANNOT be used with Order Writing			

Compact Track Loaders United States			
C227	4A	26%	8/10/2015
C232	4A	26%	8/10/2015
C238	4A	26%	8/10/2015
These models are limited to field inventory			
TS6.110	3	25%	4/28/2014
TS6.120	3	25%	4/28/2014
TS6.125	3	25%	4/28/2014
TS6.140	3	25%	4/28/2014
TS6.120 HC	3	25%	4/28/2014
T7.170 SWB	4	32%	9/1/2013
T7.185 SWB	4	32%	9/1/2013
T7.200 SWB	4	32%	9/1/2013
T7.210 SWB	4	32%	9/1/2013
T7.220 LWB	4	32%	9/1/2013
T7.235 LWB	4	32%	9/1/2013
T7.250 LWB	4	32%	9/1/2013
T7.260 LWB	4	32%	9/1/2013
T7.270 LWB	4	32%	9/1/2013
T8.275	4	35%	9/4/2013
T8.300	4	35%	9/4/2013
T8.330	4	35%	9/4/2013
T8.360	4	35%	9/4/2013
T8.390	4	35%	9/4/2013
T8.420	4	35%	9/4/2013
T9.390	4	30%	9/1/2013
T9.450	4	30%	9/1/2013
T9.505	4	30%	9/1/2013
T9.560	4	30%	9/1/2013
T9.615	4	30%	9/1/2013
T9.670	4	30%	9/1/2013
RST115		14%	9/1/2014

Home > Cooperative Purchasing > Contracts - Fleet > Landscape & Grounds Maintenance > Land Pride



Land Pride



Contract#: 070313-LPI
Category: Landscape & Grounds Maintenance
Description: Grounds Maintenance Equipment
Maturity Date: 08/20/2017

- Overview
- Contract Documentation
- Pricing
- Marketing Materials
- NJPA Contact Information

Founded in 1986, Land Pride, a Division of Great Plains Mfg., Inc., is a known leader in tractor- and skid steer-mounted grounds-maintenance, ag, and light construction equipment that include Rotary Tillers, Grooming Mowers, Seeders, Rotary Cutters, Rear Blades, Landscape Rakes, Snow Blowers, Grapples, and much more. With Corporate Offices and Engineering support based in Salina, KS, Land Pride also has manufacturing facilities in Abilene, Kipp, and Lucas, Kansas. Land Pride products are designed, built, and shipped from these Kansas facilities.

HOW TO PURCHASE ?
Our Web by State Site

Vendor Contact Info

Dee Warren
Direct Phone: 785-822-6757
dee.warren@landpride.com
www.landpride.com

John O'Brien
Direct Phone: 800-255-0132 Ext. 1324
john.obrien@landpride.com
www.landpride.com

Formal Offering of Proposal
(To be completed Only by Proposer)



GROUNDS MAINTENANCE WITH RELATED EQUIPMENT, ACCESSORIES AND SUPPLIES.

In compliance with the Request for proposal (RFP) for "GROUNDS MAINTENANCE WITH RELATED EQUIPMENT, ACCESSORIES AND SUPPLIES", the undersigned warrants that I/we have examined this RFP and, being familiar with all of the instructions, terms and conditions, general specifications, expectations, technical specifications, service expectations and any special terms, do hereby propose, fully commit and agree to furnish the defined equipment/products and related services in full compliance with all terms, conditions of this RFP, any applicable amendments of this RFP, and all Proposer's Response documentation. Proposer further understands they accept the full responsibility as the sole source of responsibility of the proposed response herein and that the performance of any sub-contractors employed by the Proposer in fulfillment of this proposal is the sole responsibility of the Proposer.

Company Name: Land Pride, a division of Great Plains Manufacturing, Inc.

Date: June 28, 2013

Company Address: 1525 E North Street

City: Salina State: Kansas Zip: 67401

Contact Person: Dee Warren Title: Marketing Manager

Authorized Signature (ink only):  Dee Warren
(Name printed or typed)



Contract Acceptance and Award

(To be completed only by NJPA)

NJPA GROUND GROUNDS MAINTENANCE WITH RELATED EQUIPMENT, ACCESSORIES AND SUPPLIES

Land Pride, a div of Great Plains Manufacturing Inc
Proposer's full legal name

Your proposal is hereby accepted and awarded. As an awarded Proposer, you are now bound to provide the defined product/equipment and services contained in your proposal offering according to all terms, conditions, and pricing set forth in this RFP, any amendments to this RFP, your Response, and any exceptions accepted or rejected by NJPA on Form C.

The effective date of the Contract will be August 20, 2013 and continue for four years thereafter AND which is subject to annual renewal at the option of both parties. This contract has the consideration of an optional fifth year renewal option at the discretion NJPA.

National Joint Powers Alliance (NJPA)

NJPA Authorized signature: [Signature] Chad Cocuette
NJPA Executive Director (Name printed or typed)

Awarded this 20th day of August, 2013 NJPA Contract Number 60000-LP1

NJPA Authorized signature: [Signature] Scott Vecchio
NJPA Board Member (Name printed or typed)

Executed this 20th day of August, 2013 NJPA Contract Number 60000-LP1

Proposer hereby accepts contract award including all accepted exceptions and NJPA clarifications identified on FORM C.

Vendor Name Land Pride, A Division of Great Plains Manufacturing, Inc.

Vendor Authorized signature: [Signature] DES WILSON
(Name printed or typed)

Title: MANUFACTURING MANAGER

Executed this 28 day of August, 2013 NJPA Contract Number 60000-LP1

RESOLUTION NO. _____

A RESOLUTION AUTHORIZING THE MAYOR AND CITY CLERK TO ACCEPT A PROPOSAL FROM MARTIN IMPLEMENTS FOR THE PURCHASE OF ONE NEW HOLLAND WORKMASTER 37 TRACTOR IN AN AMOUNT NOT TO EXCEED \$17,676

BE IT RESOLVED BY THE CITY COUNCIL OF THE CITY OF DARIEN, DU PAGE COUNTY, ILLINOIS, as follows:

SECTION 1: The City Council of the City of Darien hereby authorizes the Mayor and City Clerk to accept a proposal from Martin Implements for the purchase of one new Holland Workmaster 37 Tractor in an amount not to exceed \$17,676.00, a copy of which is attached hereto as "**Exhibit A**".

SECTION 2: This Resolution shall be in full force and effect from and after its passage and approval as provided by law.

PASSED BY THE CITY COUNCIL OF THE CITY OF DARIEN, DU PAGE COUNTY, ILLINOIS, this 2nd day of May, 2016.

AYES: _____

NAYS: _____

ABSENT: _____

APPROVED BY THE MAYOR OF THE CITY OF DARIEN, DU PAGE COUNTY, ILLINOIS, this 2nd day of May, 2016.

KATHLEEN MOESLE WEAVER, MAYOR

ATTEST:

JOANNE E. RAGONA, CITY CLERK

APPROVED AS TO FORM

CITY ATTORNEY



Martin Implement Sales, Inc.

www.martinimplement.com

Central Office

18405 115th Avenue

Orland Park, IL 60467-9489

(708) 349-8430 Phone

(708) 349-4230 Fax

West Branch

420 Nolan Drive

South Elgin, IL 60177-2238

(830) 583-3320 Phone

(847) 685-9105 Fax

North Branch

26354 N. US Highway 12

Wauconda, IL 60084-2427

(847) 489-0126 Phone

(847) 526-8054 Fax

Ship to: SAME AS BELOW

Invoice to: City of Darien
1041 S. Frontage Rd.
Darien IL 60561-5404

Attention: Tom Masek

Branch 01 - Martin Impl		
Date 04/13/2016	Time 11:30:40 (O)	Page 1
Account No. DARIE003	Phone No. 6308525000	Quote No. 17 013412
Ship Via	Purchase Order NJPA PRICE	
Sales Tax No. E9997-4487		
	Salesperson 003	

EQUIPMENT QUOTE

Description ** Q U O T E ** EXPIRY DATE: 04/13/2017 Amount

Stock #: ? Serial #: 15896.00
new New Holland Workmaster 37 tractor
with 4-wheel drive, 12 x 12 Synchro-shuttle transmission,
foldable 2-post ROPS w/seat belt, 25 x 8.50-14 4PR R3 front
Turf tires and 41 x 14.00-20 4PR R3 rear Turf tires

--
NJPA pricing = List price of \$22,079.00 less 28% =
\$15,896.00
--

Stock #: ? Serial #: 1780.00
Additional charges:
Freight, setup & delivery of tractor & mower
Add \$1,780.00

Subtotal: 17676.00
Quote Total: 17676.00

Authorization: _____

Note: NJPA bid pricing requires written purchase order.

Pricing valid not later than April 30, 2016.

--
Lou Curalli
Martin Implement Sales
708-903-1145 cell

0.
0. *
Theory 17,676.00 +
Revised 2,473.00
002.....
20,149.00
\$ 20,149.50

Selling price is F.O.B. Martin Implement Sales and does not include sales tax; add if applicable.
Equipment is subject to prior sale.

Home > Cooperative Purchasing > Contracts - Fleet > Construction & Agricultural Equipment > New Holland Ag



New Holland Ag



Contract#: 021815-CNH
Category: Construction & Agricultural Equipment
Description: Ag Tractors & Implements
Maturity Date: 03/17/2019

Overview

Contract Documentation

Pricing

Marketing Materials

NJPA Contact Information

HOW TO PURCHASE
Our step-by-step guide ?

Vendor Contact Info

Amy Swett
Direct Phone: 717-355-1686
amy.swett@newholland.com
www.newholland.com

New Holland manufactures a wide range of equipment, including a full line of tractors; hay and forage equipment; and harvesting, crop production equipment. The New Holland Agricultural lines includes Agricultural and Compact Tractors, Attachments & Loaders, Planting and Seeding, Application, Harvest, and Hay & Forage Equipment, Spreaders, and Rustler Utility Vehicles.

[New Holland Ag Products](#)

[New Holland Ag Build & Price](#)

[New Holland Ag Find a Dealer](#)

Contract Award
RFP 021815 #

FORM D



Formal Offering of Proposal
(To be completed Only by Proposer)

AGRICULTURAL TRACTORS WITH RELATED EQUIPMENT AND ACCESSORIES

In compliance with the Request for Proposal (RFP) for AGRICULTURAL TRACTORS WITH RELATED EQUIPMENT AND ACCESSORIES the undersigned warrants that I/we have examined this RFP and, being familiar with all of the instructions, terms and conditions, general specifications, expectations, technical specifications, service expectations and any special terms, do hereby propose, fully commit and agree to furnish the defined equipment/products and related services in full compliance with all terms, conditions of this RFP, any applicable amendments of this RFP, and all Proposer's Response documentation. Proposer further understands they accept the full responsibility as the sole source of responsibility of the proposed response herein and that the performance of any sub-contractors employed by the Proposer in fulfillment of this proposal is the sole responsibility of the Proposer.

Company Name: CNN INDUSTRIAL MEXICO LLC Date: FEBRUARY 17, 2015

Company Address: 701 STATE STREET

City: RACINE State: WI Zip: 53404

Contact Person: PATRICIA PLACIE Title: MANAGER, GOVERNMENT ACCOUNTS

Authorized Signature (ink only): *Patricia Placie* PATRICIA PLACIE
(Name printed or typed)



Contract Acceptance and Award

(To be completed only by NJPA)

NJPA 021815 # AGRICULTURAL TRACTORS WITH RELATED EQUIPMENT AND ACCESSORIES

CNH Industrial America, LLC

Proposer's full legal name

Your proposal is hereby accepted and awarded. As an awarded Proposer, you are now bound to provide the defined product/equipment and services contained in your proposal offering according to all terms, conditions, and pricing set forth in this RFP, any amendments to this RFP, your Response, and any exceptions accepted or rejected by NJPA on Form C.

The effective start date of the Contract will be March 17th, 20 15 and continue for four years from the board award date. This contract has the consideration of a fifth year renewal option at the discretion of NJPA.

National Joint Powers Alliance® (NJPA)

NJPA Authorized signature:

NJPA Executive Director

Dr. Chad Corvette
(Name printed or typed)

Awarded this 17th day of March, 20 15

day of March, 20 15

NJPA Contract Number 021815-CNH

NJPA Authorized signature:

NJPA Board Member

Scott Veronen
(Name printed or typed)

Executed this 17th day of March, 20 15

day of March, 20 15

NJPA Contract Number 021815-CNH

Proposer hereby accepts contract award including all accepted exceptions and NJPA clarifications identified on FORM C.

Vendor Name CNH INDUSTRIAL AMERICA, LLC

Vendor Authorized signature: Patricia Lardie

PATRICIA LARDIE
(Name printed or typed)

Title: NATIONAL GOVERNMENT ACCOUNTS MANAGER

Executed this 7th day of APRIL, 20 15

day of APRIL, 20 15

NJPA Contract Number 021815-CNH

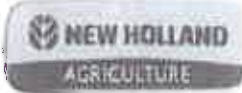

National Joint Powers Alliance
Contract # 021815
Effective 05/01/15 - 04/30/19
New Holland Equipment
For United States

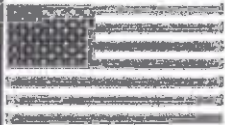

Model	Tier	List Discount for Members	Price & Data Pages Dated
BOOMER 24	4	28%	9/1/2015
BOOMER 33	4B	28%	9/1/2015
BOOMER 37	4B	28%	9/1/2015
BOOMER 41	4B	28%	9/1/2015
BOOMER 47	4B	28%	9/1/2015
BOOMER 46D	4B	28%	9/1/2015
BOOMER 64D	4B	28%	9/1/2015
Work Master 33	4B	28%	9/1/2015
Work Master 37	4B	28%	9/1/2015
Work Master 50	4B	25%	9/1/2015
Work Master 60	4B	25%	9/1/2015
Work Master 70	4B	25%	9/1/2015
Powerstar T4.65	4B	30%	9/2/2015
Powerstar T4.75	4B	30%	9/2/2015
T4.90	4B	30%	9/2/2015
T4.100	4B	30%	9/2/2015
T4.110	4B	30%	9/2/2015
T4.120	4B	30%	9/2/2015
T5.110	4B	30%	9/2/2015
T5.120	4B	30%	9/2/2015
T56.110	4B	25%	9/2/2015
T56.120	4B	25%	9/2/2015
T56.130	4B	25%	9/2/2015
T56.140	4B	25%	9/2/2015
T6.145	4B	30%	9/2/2015
T6.155	4B	30%	9/2/2015
T6.165	4B	30%	9/2/2015
T6.175	4B	30%	9/2/2015
T6.180	4B	30%	9/2/2015
T6.175	4B	30%	9/2/2015
T7.175 SWB	4B	32%	10/1/2016
T7.190 SWB	4B	32%	10/1/2016
T7.210 SWB	4B	32%	10/1/2016
T7.230 LWB	4B	32%	10/1/2016
T7.245 LWB	4B	32%	10/1/2016
T7.260 LWB	4B	32%	10/1/2016
T7.270 LWB	4B	32%	10/1/2016
T7.280 HD CVT	4B	32%	10/1/2016
T7.315 HD CVT	4B	32%	10/1/2016

Model	Tier	List Discount for Members	Price & Data Pages Dated
T8.320	4B	35%	10/1/2015
T8.350	4B	35%	10/1/2015
T8.380	4B	35%	10/1/2015
T8.410	4B	35%	10/1/2015
T8.435	4B	35%	10/1/2015
T9.435	4B	30%	10/1/2015
T9.480	4B	30%	10/1/2015
T9.530	4B	30%	10/1/2015
T9.565	4B	30%	10/1/2015
T9.600	4B	30%	10/1/2015
T9.645	4B	30%	10/1/2015
T9.700	4B	30%	10/1/2015
T9 Tracks		27%	10/1/2015
RST120		14%	7/1/2015
RST125		14%	7/1/2015
Implements		25%	9/1/2015
805TL Loaders		25%	9/1/2015
600/605TL Loaders		25%	9/1/2015
Compact Loaders		25%	9/1/2015
Crop Packaging		25%	9/2/2015
Crop Preparation		25%	9/2/2015
Self-Propelled Pull Type		25%	9/2/2015
Tractor Front-End		25%	9/2/2015
Tractor Rear-End		25%	9/2/2015
Tractor PTO		25%	10/1/2015
Tractor HST		25%	10/1/2015
Tractor		25%	7/7/2015
Tractor		25%	7/7/2015
LM5.25		25%	9/1/2015
LM6.28		25%	9/1/2015
LM6.32		25%	9/1/2015
LM7.42		25%	9/1/2015
LM9.35		25%	9/1/2015
Tractor		25%	7/7/2015



National Joint Powers Alliance
Contract # 021915
Effective 05/01/15 - 04/30/19
New Holland Equipment
For United States



Skid Steers United States			
L213	4F	24%	10/17/2014
L216	4F	24%	10/17/2014
L218	4F	26%	10/17/2014
L220	4F	25%	10/17/2014
L221	4F	25%	10/17/2014
L228	4F	26%	10/17/2014
L230	4F	32%	10/17/2014

Compact Track Loaders United States			
C227	4F	26%	10/15/2014
C232	4F	26%	10/18/2014
C238	4F	26%	10/15/2014

These models are limited to Field Inventory

These models are limited to Field Inventory

BOOMER 20	4A	28%	9/1/2013
BOOMER 25	4A	28%	9/1/2013
BOOMER 3040		28%	9/1/2014
BOOMER 3045		28%	9/1/2014
BOOMER 3050		28%	9/1/2014
BOOMER 30	4A	28%	9/1/2013
BOOMER 35	3	28%	9/1/2013
BOOMER 40		28%	9/1/2013
BOOMER 50		28%	9/1/2013

TSS.110	3	25%	4/28/2014
TSS.120	3	25%	4/28/2014
TSS.128	3	25%	4/28/2014
TSS.140	3	25%	4/28/2014
TSS.120 HC	3	25%	4/28/2014
T7.170 SWB	4	32%	9/1/2013
T7.185 SWB	4	32%	9/1/2013
T7.200 SWB	4	32%	9/1/2013
T7.210 SWB	4	32%	9/1/2013

Work Master 35	3	28%	9/1/2014
Work Master 40	3	28%	9/1/2014
Work Master 45	4A	25%	9/1/2014
Work Master 55	4A	25%	9/1/2014
WorkMaster 65	3	25%	9/1/2014
WorkMaster 75	3	25%	9/1/2014

T7.220 LWB	4	32%	9/1/2013
T7.235 LWB	4	32%	9/1/2013
T7.250 LWB	4	32%	9/1/2013
T7.260 LWB	4	32%	9/1/2013
T7.270 LWB	4	32%	9/1/2013

T4.85	4A	30%	9/1/2014
T4.95	4A	30%	9/1/2014
T4.103	4A	30%	9/1/2014
T4.115	4A	30%	9/1/2014

T8.275	4	35%	9/4/2013
T8.300	4	35%	9/4/2013
T8.330	4	35%	9/4/2013
T8.350	4	35%	9/4/2013
T8.390	4	35%	9/4/2013
T8.420	4	35%	9/4/2013

T5.95	4A	30%	9/1/2014
T5.105	4A	30%	9/1/2014
T5.115	4A	30%	9/1/2014

T9.390	4	30%	9/1/2013
T9.450	4	30%	9/1/2013
T9.505	4	30%	9/1/2013
T9.550	4	30%	9/1/2013
T9.615	4	30%	9/1/2013
T9.670	4	30%	9/1/2013

T6.140	4A	30%	9/1/2014
T6.150	4A	30%	9/1/2014
T6.160	4A	30%	9/1/2014
T6.155	4A	30%	9/1/2014
T6.165	4A	30%	9/1/2014
T6.175	4A	30%	9/1/2014

RST116		14%	9/1/2014
--------	--	-----	----------

*Actual qty, price, weight and date to be determined
 *These discounts apply to orders placed with
 order writing



National Joint Powers Alliance
 Contract # 021815
 Effective 05/01/15 - 04/30/19
 New Holland Equipment
 For Canada



Model	Tier	List Discount for All models	Price & Data Pages Dated
BOOMER 24	4	28%	9/1/2015
BOOMER 33	4B	28%	9/1/2015
BOOMER 37	4B	28%	9/1/2015
BOOMER 41	4B	28%	9/1/2015
BOOMER 47	4B	28%	9/1/2015
BOOMER 46D	4B	28%	9/1/2015
BOOMER 54D	4B	28%	9/1/2015
Work Master 33	4B	28%	9/1/2015
Work Master 37	4B	28%	9/1/2015
Work Master 50	4B	25%	9/1/2015
Work Master 60	4B	25%	9/1/2015
Work Master 70	4B	25%	9/1/2015
Powerstar T4.65	4B	30%	9/2/2015
Powerstar T4.75	4B	30%	9/2/2015
T4.90	4B	30%	9/2/2015
T4.100	4B	30%	9/2/2015
T4.110	4B	30%	9/2/2015
T4.120	4B	30%	9/2/2015
T5.110	4B	30%	9/2/2015
T5.120	4B	30%	9/2/2015
T56.110	4B	25%	9/2/2015
T56.120	4B	25%	9/2/2015
T56.130	4B	25%	9/2/2015
T56.140	4B	25%	9/2/2015
T6.145	4B	30%	9/2/2015
T6.155	4B	30%	9/2/2015
T6.165	4B	30%	9/2/2015
T6.175	4B	30%	9/2/2015
T6.180	4B	30%	9/2/2015
T6.175	4B	30%	9/2/2015
T7.175 SWB	4B	32%	10/2/2015
T7.190 SWB	4B	32%	10/2/2015
T7.210 SWB	4B	32%	10/2/2015
T7.230 LWB	4B	32%	10/2/2015
T7.245 LWB	4B	32%	10/2/2015
T7.260 LWB	4B	32%	10/2/2015
T7.270 LWB	4B	32%	10/2/2015
T7.290 HD CVT	4B	32%	10/2/2015
T7.315 HD CVT	4B	32%	10/2/2015

Model	Tier	List Discount for All models	Price & Data Pages Dated
T8.320	4B	35%	10/2/2015
T8.350	4B	35%	10/2/2015
T8.390	4B	35%	10/2/2015
T8.410	4B	35%	10/2/2015
T8.435	4B	35%	10/2/2015
T9.435	4B	30%	10/2/2015
T9.480	4B	30%	10/2/2015
T9.530	4B	30%	10/2/2015
T9.555	4B	30%	10/2/2015
T9.600	4B	30%	10/2/2015
T9.645	4B	30%	10/2/2015
T9.700	4B	30%	10/2/2015
T9 Tracks		27%	10/1/2015
RST120		14%	7/1/2015
RST125		14%	7/1/2015
Implements		25%	9/1/2015
805TL Loaders		25%	9/1/2015
600/605TL Loaders		25%	9/1/2015
Compact Loaders		25%	9/1/2015
Self-Propelled		25%	9/3/2015
Crop Packaging		25%	9/3/2015
Crop Preparation		25%	9/2/2015
Full Type		25%	9/2/2015
Self-Propelled		25%	9/3/2015
Full Type		25%	9/2/2015
Self-Propelled		25%	9/3/2015
Full Type		25%	9/2/2015
Self-Propelled		25%	8/10/2015
Full Type		25%	8/10/2015
Self-Propelled		25%	8/10/2015
Full Type		25%	8/10/2015
LM5.25		25%	9/1/2015
LM6.28		25%	9/1/2015
LM6.32		25%	9/1/2015
LM7.42		25%	9/1/2015
LM8.35		25%	9/1/2015
LM9.35		25%	9/1/2015
LM9.35		25%	5/10/2015



National Joint Powers Alliance
 Contract # 021815
 Effective 05/01/15 - 04/30/19
 New Holland Equipment
 For Canada



Skid Steers United States			
L213	4A	24%	8/10/2015
L215	4A	24%	8/10/2015
L218	4A	28%	8/10/2015
L220	4A	25%	8/10/2015
L221	4F	25%	8/10/2015
L223	4A	28%	8/10/2015
L225	4A	28%	8/10/2015
L230	4A	32%	8/10/2015
These models are limited to Field Inventory			
BOOMER 20	4A	28%	9/1/2013
BOOMER 25	4A	28%	9/1/2013
BOOMER 3040		28%	9/1/2014
BOOMER 3045		28%	9/1/2014
BOOMER 3050		28%	9/1/2014
BOOMER 30	4A	28%	9/1/2013
BOOMER 35	3	28%	9/1/2013
BOOMER 40		28%	9/1/2013
BOOMER 50		28%	9/1/2013
Work Master 35	3	28%	9/1/2014
Work Master 40	3	28%	9/1/2014
Work Master 45	4A	25%	9/1/2014
Work Master 55	4A	25%	9/1/2014
WorkMaster 65	3	25%	9/1/2014
WorkMaster 75	3	25%	9/1/2014
T4.85	4A	30%	9/1/2014
T4.95	4A	30%	9/1/2014
T4.105	4A	30%	9/1/2014
T4.115	4A	30%	9/1/2014
T5.95	4A	30%	9/1/2014
T5.105	4A	30%	9/1/2014
T5.115	4A	30%	9/1/2014
T6.140	4A	30%	9/1/2014
T6.150	4A	30%	9/1/2014
T6.160	4A	30%	9/1/2014
T6.155	4A	30%	9/1/2014
T6.165	4A	30%	9/1/2014
T6.175	4A	30%	9/1/2014

Compact Track Loaders United States			
C227	4A	26%	8/10/2015
C232	4A	26%	8/10/2015
C238	4A	26%	8/10/2015
These models are limited to Field Inventory			
TS6.110	3	25%	4/28/2014
TS6.120	3	25%	4/28/2014
TS6.125	3	25%	4/28/2014
TS6.140	3	25%	4/28/2014
TS6.120 HC	3	25%	4/28/2014
T7.170 SWB	4	32%	9/1/2013
T7.185 SWB	4	32%	9/1/2013
T7.200 SWB	4	32%	9/1/2013
T7.210 SWB	4	32%	9/1/2013
T7.220 LWB	4	32%	9/1/2013
T7.235 LWB	4	32%	9/1/2013
T7.250 LWB	4	32%	9/1/2013
T7.260 LWB	4	32%	9/1/2013
T7.270 LWB	4	32%	9/1/2013
T8.275	4	35%	9/4/2013
T8.300	4	35%	9/4/2013
T8.330	4	35%	9/4/2013
T8.360	4	35%	9/4/2013
T8.390	4	35%	9/4/2013
T8.420	4	35%	9/4/2013
T9.390	4	30%	9/1/2013
T9.450	4	30%	9/1/2013
T9.505	4	30%	9/1/2013
T9.560	4	30%	9/1/2013
T9.615	4	30%	9/1/2013
T9.670	4	30%	9/1/2013
RST115		14%	9/1/2014

Dealer can add freight and set-up to the purchase orders. These discounts CANNOT be used with Order Writing

RESOLUTION NO. _____

A RESOLUTION AUTHORIZING THE MAYOR AND CITY CLERK TO ACCEPT A PROPOSAL FROM LAND PRIDE FOR THE PURCHASE OF A LAND PRIDE 16 SERIES GROOMING MOWER ATTACHMENT IN AN AMOUNT NOT TO EXCEED \$2,473.50

BE IT RESOLVED BY THE CITY COUNCIL OF THE CITY OF DARIEN, DU PAGE COUNTY, ILLINOIS, as follows:

SECTION 1: The City Council of the City of Darien hereby authorizes the Mayor and City Clerk to accept a proposal from Land Pride for the purchase of a Land Pride 16 Series Grooming Mower attachment in an amount not to exceed \$2,473.50, a copy of which is attached hereto as **“Exhibit A”**.

SECTION 2: This Resolution shall be in full force and effect from and after its passage and approval as provided by law.

PASSED BY THE CITY COUNCIL OF THE CITY OF DARIEN, DU PAGE COUNTY, ILLINOIS, this 2nd day of May, 2016.

AYES: _____

NAYS: _____

ABSENT: _____

APPROVED BY THE MAYOR OF THE CITY OF DARIEN, DU PAGE COUNTY, ILLINOIS, this 2nd day of May, 2016.

KATHLEEN MOESLE WEAVER, MAYOR

ATTEST:

JOANNE E. RAGONA, CITY CLERK

APPROVED AS TO FORM

CITY ATTORNEY

Home > Cooperative Purchasing > Contracts - Fleet > Landscape & Grounds Maintenance > Land Pride



Land Pride



Contract#: 070313-LPI
Category: Landscape & Grounds Maintenance
Description: Grounds Maintenance Equipment
Maturity Date: 08/20/2017

Overview

Contract Documentation

Pricing

Marketing Materials

NJPA Contact Information

HOW TO PURCHASE
Our way by step article ?

Vendor Contact Info

Dee Warren
Direct Phone: 785-822-6757
dee.warren@landpride.com
www.landpride.com

John O'Brien
Direct Phone: 800-255-0132 Ext. 1324
john.obrien@landpride.com
www.landpride.com

Founded in 1986, Land Pride, a Division of Great Plains Mfg., Inc., is a known leader in tractor- and skid steer-mounted grounds-maintenance, ag, and light construction equipment that include Rotary Tillers, Grooming Mowers, Seeders, Rotary Cutters, Rear Blades, Landscape Rakes, Snow Blowers, Grapples, and much more. With Corporate Offices and Engineering support based in Salina, KS, Land Pride also has manufacturing facilities in Abilene, Kipp, and Lucas, Kansas. Land Pride products are designed, built, and shipped from these Kansas facilities.



GROUNDS MAINTENANCE WITH RELATED EQUIPMENT, ACCESSORIES AND SUPPLIES.

In compliance with the Request for proposal (RFP) for "GROUNDS MAINTENANCE WITH RELATED EQUIPMENT, ACCESSORIES AND SUPPLIES", the undersigned warrants that I/we have examined this RFP and, being familiar with all of the instructions, terms and conditions, general specifications, expectations, technical specifications, service expectations and any special terms, do hereby propose, fully commit and agree to furnish the defined equipment/products and related services in full compliance with all terms, conditions of this RFP, any applicable amendments of this RFP, and all Proposer's Response documentation. Proposer further understands they accept the full responsibility as the sole source of responsibility of the proposed response herein and that the performance of any sub-contractors employed by the Proposer in fulfillment of this proposal is the sole responsibility of the Proposer.

Company Name: Land Pride, a division of Great Plains Manufacturing, Inc.

Date: June 28, 2013

Company Address: 1525 E North Street

City: Salina State: Kansas Zip: 67401

Contact Person: Dee Warren Title: Marketing Manager

Authorized Signature (ink only):  Dee Warren
(Name printed or typed)



Contract Acceptance and Award

(To be completed only by NJPA)

NJPA GROUND GROUNDS MAINTENANCE WITH RELATED EQUIPMENT, ACCESSORIES AND SUPPLIES

Land Pride, a div. of Great Plains Manufacturing, Inc.
Proposer's full legal name

Your proposal is hereby accepted and awarded. As an awarded Proposer, you are now bound to provide the defined product/equipment and services contained in your proposal offering according to all terms, conditions, and pricing set forth in this RFP, any amendments to this RFP, your Response, and any exceptions accepted or rejected by NJPA on Form C.

The effective date of the Contract will be August 20, 2013 and continue for four years thereafter AND which is subject to annual renewal at the option of both parties. This contract has the consideration of an optional fifth year renewal option at the discretion NJPA.

National Joint Powers Alliance (NJPA)

NJPA Authorized signature: [Signature]
NJPA Executive Director Chad Coghille
(Name printed or typed)

Awarded this 20th day of August, 2013 NJPA Contract Number 600001-LP1

NJPA Authorized signature: [Signature]
NJPA Board Member Scott Vignone
(Name printed or typed)

Executed this 20th day of August, 2013 NJPA Contract Number 600001-LP1

Proposer hereby accepts contract award including all accepted exceptions and NJPA clarifications identified on FORM C.

Vendor Name Land Pride, a Division of Great Plains Manufacturing, Inc.

Vendor Authorized signature: [Signature]
DEE WARDEN
(Name printed or typed)

Title: MANAGER

Executed this 28 day of August, 2013 NJPA Contract Number 600001-LP1

AGENDA MEMO
Municipal Services Committee
April 25, 2016

Issue Statement

Consideration for the authorization to execute an Illinois Department of Transportation Resolution, (IDOT BLR 14230) authorizing the expenditure of Motor Fuel Tax (MFT) funds for the FY 2016/17 General Maintenance items in the amount of \$614,315 for a period from May 1, 2016 through April 30, 2017. BACKUP

Background/History

The City of Darien utilizes Motor Fuel Tax Funds (MFT) for expenditures related to various street maintenance functions. The funding provides for expenditures for such items as salaries, the purchase of rock salt, cold and hot bituminous surface mixes, storm sewer related items, various aggregate materials and road striping. Because MFT funds are utilized, the City Council is required to adopt a resolution authorizing the expenditure of the proposed funding related to the general maintenance items. Attached as, Attachment A is the Bureau of Local Road Forms Municipal Estimate of Maintenance Costs and Request for Expenditure/Authorization of Motor Fuel Tax Funds (BLR 14231 and BLR09150).

Staff Recommendation

Staff recommends approval of this Resolution.

Alternate Consideration

Not approving the Resolution.

DECISION MODE

This item will be placed on the May 2, 2016 City Council agenda for formal consideration.



CITY OF DARIEN

In the County of DuPage and the State of Illinois
Incorporated 1969

April 18, 2016

Mr. John Fortman, P.E.
Deputy Directors of Highways,
Region One Engineer
Division of Highways/Region One/District One
201 West Center Ct.
Schaumburg, IL 60196-1096

RE: Section Number 16-00000-00-RF

Dear Mr. Fortman:

In accordance with the Bureau of Local Roads and Streets Administrative Policy Manual, the following is an estimate of the allotted MFT monies to spend by the City during the Fiscal Year ending April 30, 2017:

Estimated Total Expenditures for:

FICA	\$15,190
IMRF	\$33,222
MEDICARE	\$ 3,553
TOTAL	\$51,965

If you have any questions regarding this matter, please contact Dan Gombac, Director of Municipal Services at dgombac@darienil.gov or via telephone at (630)353-8106.

Sincerely,
CITY OF DARIEN

Daniel Gombac
Director of Municipal Services

cc: Bryon Vana, City Administrator
Paul Nosek, Assistant City Administrator
Marie Kyriakoulis, City Accountant



Municipal Estimate of Maintenance Costs

Local Public Agency: City of Darien
 County: DuPage

Maintenance Period 5/1/2016 to 4/30/2017

Section Number: 17-00000-00-GM

Estimated Cost of Maintenance Operations

Maintenance Operation (No. Description)	Maint. Group	Insp. Req.	For Group I, IIA, IIB, or III				Est Total Operation Cost	
			Item	Unit	Quantity	Unit Price		Item Cost
1) Aggregate (Shoulder Maint) (Culvert Backfill)	IIA		Stone CA-6 CA-7	Tons	1000.00	13.26	13,260.00	19,020.00
	IIA		Labor-5 Gen Util Wkrs	Av Hr	160.00	36.00	5,760.00	
2) Pavement Patching (2 different vendors will be used for bituminous purchase)	IIA		Surface Bituminous Hot	Tons	310.00	53.04	16,442.40	86,215.40
	IIA		Labor-5 Gen Util Wkrs	Av Hr	1350.00	35.00	48,600.00	
	IIA		Surface Bituminous Cold	Tons	100.00	67.73	6,773.00	
	IIA		Labor-5 Gen Util Wkrs	Av Hr	400.00	36.00	14,400.00	
3) Snow & Ice Control	IA		Road Salt-Joint Purchase with DuPage County	Tons	3220.00	74.00	238,280.00	279,400.00
	IIA		Labor-5 Gen Util Wkrs	Av Hr	1500.00	36.00	54,000.00	
4) Storm Sewer Maint	IIA		Culvert Pipe	LS	1.00	15,000.00	15,000.00	78,000.00
	IIA		Labor-5 Gen Util Wkrs	Av Hr	1750.00	36.00	63,000.00	
5) Pavement Marking	IIA		Striping-Paint-Thermal	LS	1.00	13,000.00	13,000.00	11,364.00
	IIA		Labor-5 Gen Util Wkrs	Av Hr	24.00	36.00	864.00	
6) Street Sign Maint	IIA		Labor-5 Gen Util Wkrs	Av Hr	300.00	36.00	10,800.00	10,800.00
7) Mowing (Public ROW)	IIA		Labor-5 Gen Util Wkrs	Av Hr	1510.00	29.00	43,790.00	43,790.00
8) Catch Basin Cleaning	IIA		Labor-5 Gen Util Wkrs	Av Hr	110.00	36.00	3,960.00	3,960.00
9) Emerald Ash Borer Removals	IIA		Tree Removal-Emerald Ash Borer	DBH	500.00	30.00	15,000.00	15,000.00
Total Estimated Maintenance Operation Cost							547,549.40	

	Estimated Cost	MFT Portion	Other Funds	Preliminary Engineering
Maintenance	547,549.40		547,549.40	Engineering Inspection
Maint Eng	-		-	Material Testing
Totals:	547,549.40	-	547,549.40	Advertising
				Bridge Inspections
				Total Estimated Maintenance Engineering Cost
				Total Estimated Maintenance Cost
				547,549.40

Submitted:

Approved:

Municipal Official Title

Regional Engineer

Date

Date



**Request for
Expenditure/Authorization
of Motor Fuel Tax Funds**

For District Use Only	
Transaction Number	
Date	
Checked by	

Municipality City of Darien

County Dupage

Rd. District _____

Section 17-00000-00-RF

I hereby request authorization to expend Motor Fuel Tax Funds as indicated below.

Purpose	Amount
Contract Construction	0.00
Day Labor Construction	0.00
Right-of-Way (Itemized On Reverse Side)	0.00
Engineering	0.00
Maintenance Engineering	0.00
Engineering Investigations	0.00
Other Category	0.00
Obligation Retirement	0.00
Maintenance	0.00
Co. Eng./Supt. Salary & (Period _____ to _____)	0.00
IMRF or Social Security	51,965.00
Interest _____	

Total	\$ 51,965.00

Comments _____

Date May 2 , 2016

Signed by _____

City Clerk
Title of Official

Approved

Date
Department of Transportation

Regional Engineer



Resolution for Maintenance of Streets and Highways by Municipality Under the Illinois Highway Code

BE IT RESOLVED, by the City Council of the City of Darien, Illinois, that there is hereby appropriated the sum of \$614,315.00 of Motor Fuel Tax funds for the purpose of maintaining streets and highways under the applicable provisions of the Illinois Highway Code from May 1, 2016 to April 30, 2017

BE IT FURTHER RESOLVED, that only those streets, highways, and operations as listed and described on the approved Municipal Estimate of Maintenance Costs, including supplemental or revised estimates approved in connection with this resolution, are eligible for maintenance with Motor Fuel Tax funds during the period as specified above.

BE IT FURTHER RESOLVED, that the Clerk shall, as soon a practicable after the close of the period as given above, submit to the Department of Transportation, on forms furnished by said Department, a certified statement showing expenditures from and balances remaining in the account(s) for this period; and

BE IT FURTHER RESOLVED, that the Clerk shall immediately transmit two certified copies of this resolution to the district office of the Department of Transportation, at Schaumburg, Illinois.

I, JoAnne E. Ragona Clerk in and for the City of Darien, County of DuPage

hereby certify the foregoing to be a true, perfect and complete copy of a resolution adopted by

the City Council at a meeting on May 2, 2016

IN TESTIMONY WHEREOF, I have hereunto set my hand and seal this 2nd day of May, 2016

(SEAL) City Clerk

Approved
Regional Engineer
Department of Transportation
Date

AGENDA MEMO
Municipal Services Committee Meeting
April 25, 2016

ISSUE STATEMENT

A resolution accepting a proposal from Accurate Tank for the Decommissioning of the Stage 2 Vapor Recovery System, cleaning and televising of the fuel tanks at the Public Works Facility, 1041 S Frontage Road in an amount not to exceed \$11,040.

BACKGROUND/HISTORY

The Stage II Vapor recovery systems were required to be on commercial fuel dispensing facilities in DuPage County since the mid-1990's. The EPA has determined that the vapor recovery systems on most vehicles is enough to replace the dispenser based equipment. Therefore, all Stage II Vapor Recovery Systems at commercial fuel dispensing facilities need to be decommissioned no later than December 31, 2016. Pending the cleaning process, videotaping of the inside of the tanks may be required to record conditions.

The proposed work is for the decommissioning of the stage 2 vapor recovery system from the underground fuel storage tanks. Accurate Tank will notify and coordinate inspections and protocol with the EPA of the plan to decommission. The work includes the following:

- Relieve the pressure in the tank ullage and disconnect all vapor processing units
- Seal off vapor piping inside the dispenser below grade and at the tank, if accessible
- Replace all stage 2 hanging hardware including hoses with conventional hardware and hoses
- Install new filter housings and filters
- Install new pressure vacuum vent cap
- Remove all stage 2 operating instructions from the fuel dispensers
- Conduct pressure decay testing
- Complete the checklist documenting
- Submit all required paperwork back into the EPA

Attached and labeled as Attachment A and Attachment B, are the competitive quote results for:

Item 1-Decommissioning of the Stage 2 Vapor Recovery System

Item 2-Cleaning and Inspection

The proposed expenditure would be expended from the following line accounts:

ACCOUNT NUMBER	ACCOUNT DESCRIPTION	FY 16-17 BUDGET	PROPOSED EXPENDITURE	CONTINGENCY	PROPOSED TOTAL COST	PROPOSED BALANCE
01-30-4223	OPERATING-FUEL PUMP MTCE-DECOMMISSION	\$ 2,625.00	\$ 1,035.00	\$ 500.00	\$ 1,535.00	\$ 1,090.00
02-50-4223	OPERATING-FUEL PUMP MTCE-DECOMMISSION	\$ 2,625.00	\$ 1,035.00	\$ 500.00	\$ 1,535.00	\$ 1,090.00
01-30-4223	OPERATING-FUEL PUMP MTCE-CLEANING	\$ 4,660.00	\$ 3,235.00	\$ 750.00	\$ 3,985.00	\$ 675.00
02-50-4223	OPERATING-FUEL PUMP MTCE-CLEANING	\$ 4,660.00	\$ 3,235.00	\$ 750.00	\$ 3,985.00	\$ 675.00
TOTALS		\$ 14,570.00	\$ 8,540.00	\$ 2,500.00	\$ 11,040.00	\$ 3,530.00

2016 Fuel Tank Maintenance

April 25, 2016

Page 2

STAFF RECOMMENDATION

Staff recommends accepting a proposal from Accurate Tank for the Decommissioning of the Stage 2 Vapor Recovery System and cleaning of the fuel tanks at the Public Works Facility, 1041 S Frontage Road in an amount not to exceed \$11,040.

ALTERNATE DECISION

As recommended by the Committee.

DECISION MODE

This item will be on the May 2, 2016 City Council agenda for formal consideration.

1 DAY JOB BOTH TANKS

ESTIMATE

DATE: March 17, 2016



204 Poplar Place North Aurora, IL 60542
 Office: 630 318 1812 direct Fax: 630 844 0091
 Cell: 630 721 7468

Estimated By: Virgil McCorkle
 virgilmccorkle@accuratetank.com

Location: City of Darien

Terms: Net 30

Kris Throm
 Water department foreman
 Ph.
 Fax.
 e-mail: kthrom@darienil.gov
 Fac. LD.#2034534

JOB DESCRIPTION

Quote to empty 2 underground tanks of products and hold on-site; Estimate 2-3000 gallons of gasoline and 4000 gallons of diesel

Completely clean interior of both tanks with pressurized, articulated power washing head (Gama-Jer)

Remove waste from both tanks. Once tanks are deemed completely clean, drop products back into tanks, filtering products during process.

Remove and legally dispose of all waste

ITEMIZED ESTIMATE

As described above	cleaning of 2 tanks. COMPLETED SAME DAY.	\$ 6,500 6,470
Waste disposal @ .45 cents per gallon. ESTIMATED 1000 gallons		\$ 450 estimated
Additional pricing for video taping of interior of 2 tanks after cleaning		\$ 315
TOTAL ESTIMATED JOB COST		\$ 7,265

To: Kris Throm <kthrom@darienil.gov>
Subject: RE: Darien Estimates

I can let you know tomorrow.
Out of the office today

Sent via the Samsung GALAXY S@4 Active™, an AT&T 4G LTE smartphone

----- Original message -----

From: Kris Throm <kthrom@darienil.gov>
Date: 04/13/2016 10:52 AM (GMT-06:00)
To: Virgil McCorkle <virgilmccorkle@AccurateTank.com>
Cc: John Carr <johncarr@darienil.gov>
Subject: RE: Darien Estimates

Virgil,

I was submitting the quotes that you had recently provided to John Carr to our Director and he wanted to know Accurate Tank would be willing to meet a competitor's quote for the tank cleaning. Their quote was for \$6,470.00 and included the waste disposal. We would still be willing to pay the additional \$315.00 for videotaping of the tank after the cleaning. If you agree to the changes the City of Darien would be awarding both the tank cleaning and Stage 2 decommissioning to Accurate Tank. Please let me know at your earliest convenience.

Thanks,

Kris Throm
City of Darien Municipal Services
Water Department Foreman
(630) 514-3453

Please sign up for Darien Direct Connect Newsletter, the best way to receive current information for the community. Just click on this link and enter your e-mail address! <http://www.darien.il.us/Departments/Administration/CityNews.html>

-----Original Message-----

From: Kris Throm
Sent: Thursday, March 17, 2016 11:36 AM
To: John Carr <johncarr@darienil.gov>
Cc: Dan Salvato <dsalvato@darienil.gov>
Subject: FW: Darien Estimates

John,

See below from Dan G.

Thanks,

Kris Throm
City of Darien Municipal Services
Water Department Foreman
(630) 514-3453

Please sign up for Darien Direct Connect Newsletter, the best way to receive current information for the community. Just click on this

Lisa Klemm

From: Kris Throm
Sent: Thursday, April 14, 2016 8:45 AM
To: Dan Gombac; Lisa Klemm
Subject: FW: Darien Estimates

See below for budget

Kris Throm
City of Darien Municipal Services
Water Department Foreman
(630) 514-3453

Please sign up for Darien Direct Connect Newsletter, the best way to receive current information for the community. Just click on this link and enter your e-mail address!
<http://www.darien.il.us/Departments/Administration/CityNews.html>

From: Virgil McCorkle [mailto:virgilmccorkle@AccurateTank.com]
Sent: Thursday, April 14, 2016 8:22 AM
To: Kris Throm <kthrom@darienil.gov>
Subject: RE: Darien Estimates

Hello Kris,

Yes, we will meet the \$ 6470 for tank cleaning and still hold Stage II decommissioning @ \$ 2070 for a total of \$ 8540

Thank you for considering us.

The tank cleaning company indicated that both tanks had to be cleaned on the same day so only 1 trip for them

From: Kris Throm [mailto:kthrom@darienil.gov]
Sent: Wednesday, April 13, 2016 11:12 AM
To: Virgil McCorkle
Subject: RE: Darien Estimates

Great, thanks Virgil! Enjoy your day off

Kris Throm
City of Darien Municipal Services
Water Department Foreman
(630) 514-3453

To receive important information from the City of Darien sign up for our electronic newsletter:

DARIEN DIRECT CONNECT

Follow the link below and subscribing is simple! <http://www.darien.il.us/Reference-Desk/DirectConnect.aspx>

From: Virgil McCorkle [mailto:virgilmccorkle@AccurateTank.com]
Sent: Wednesday, April 13, 2016 11:10 AM

March 07, 2016

www.aqs-services.com

Village of Darien DPW
1041 South Frontage Road
Darien, Illinois 60561

Site: Village of Darien DPW
1041 South Frontage Road
Darien, Illinois 60561

We propose to complete Stage II vapor recovery system decommission for a commercial single-hose per side dispenser per the Illinois Environmental Protection Agency regulations and as follows:

BASE BID

QTY

- 1.00 Drain Liquid collection points if necessary.
- 1.00 Disconnect and cap the existing vapor recovery piping under the dispensers.
- 1.00 Disconnect and plug the vapor recovery piping at the tanks if possible.
- 2.00 Remove and dispose of the existing vapor recovery hose sets.
- 2.00 Remove the existing high hose retractors.
- 2.00 Furnish and install new 3/4" diameter standard adapters, hoses, breakaways, swivels and nozzles on the existing dispensers connected to the existing dispenser internal hose retractor system.
- 1.00 Reprogram the dispenser for non-vapor recovery operation.

BASE BID TOTAL \$1,400.00

PRESSURE DECAY & VENT TESTING

Furnish pressure decay and pressure/vacuum vent head testing to confirm that the entire vapor system is air tight.

1.0 **PRESSURE DECAY & VENT TESTING TOTAL \$865.00**

NOTES: This proposal does not include the following items:

- a) disposal of any liquid that cannot be returned to the tanks.
- b) any work requiring excavation.
- c) any work that may arise from a failed pressure decay test, or
- d) required removal of Stage II instructional decals from the dispenser faces.

New hose sets will have a parts only warranty of 12 months from the date of installation.

Pressure decay testing results will be available 28 days after completion of the dispenser conversion. (If your system has not had a recent pressure decay test, it is possible that tank top items such as spill containers, drop tubes, vent heads and other items could fail the test and have to be replaced.)

All applications and final notification forms will be completed by AQS Services, Inc. with final signatures and submittal to the Illinois EPA to be completed by the site owner.

This proposal was prepared using information from the Illinois State Fire Marshall web site.

TERMS: Net 30 days.

PREPARED BY: _____

ACCEPTED BY: _____ **DATE** _____

Handwritten in red ink:
\$2265.00

METRO

TANK AND PUMP COMPANY

1111 West Dundee Road Wheeling, IL 60090-3936

Phone: (847) 465-4000 Fax: (847) 465-1864

WEBSITE: WWW.METROTANK.COM EMAIL: INFO@METROTANK.COM

Mr. John Carr
City of Darien
1041 S. Frontage Rd
Darien, IL 60561

March 15, 2016

Dear Mr. Carr;

METRO Tank & Pump Company is pleased to provide our proposal for services pertaining to the Darien Public Works location.

JOB DESCRIPTION

All work will be performed in compliance with the most current guidelines of the OSMF, IEPA and OSHA.

- ◆ Mobilize crew and equipment to site to include hot water tank supply.
 - ◆ Pump out and hold gasoline and diesel fuels in our holding tank.
- Note: No more than 5,000 gallons per product can be held.
- ◆ Insert 360 degree spinning rod through existing tank top opening/s and perform power-washing of tank's interior.
 - ◆ Dispose of tanks' rinsates.
 - ◆ Reinstall tank top fittings.
 - ◆ Return fuel to tanks.

Price: \$6,470

Respectfully,
METRO Tank and Pump Company
Hajlije Memia
Account Executive

Payment Terms: Signed Contract/Purchase Order,
Net 30 days.

Accepted By: _____ Print Name: _____ Title: _____ Date: _____

The following Terms and Conditions between **METRO** Tank & Pump Company (hereafter Contractor) and City of Darien (hereafter Purchaser) are affixed and made a part hereof. Please sign in the appropriate place to indicate your acceptance.



Services Inc.

www.aqs-services.com

April 8, 2016

Attention: John Carr
Village of Darien DPW
1041 South Frontage Road
Darien, Illinois 60561

Ref: Darien Municipal Services Facility Cleaning of 6,000 Gallon Gasoline Tank and 12,000 Diesel Tank.

Dear Mr. Carr,

AQS Services, Inc. is pleased to provide the following budgetary estimate to clean the interior of a 6,000 gallon gasoline tank and a 12,000 gallon diesel fuel tank. All work shall be performed in compliance with federal, state and local regulations. AQS Services shall have Palatine Fuels pump down the tanks to the sludge line and retain or replace fuels for reuse. AQS services, Inc. will remove the drop tube and cover, high pressure water wash tanks to remove any residual sludge from the bottom of the tanks and transport and dispose of the wash water waste.

Estimated Duration: (2) Two Days @ 10 hours per day Monday through Friday

Estimated price..... \$11,475.00

Disposal is \$.65/gallon. Estimated 700 gallons of liquid waste disposal depending on residual sludge in the tank.

.65 x 500 = 325.00

AQS Service shall provide supervision, labor, equipment, and disposal of waste to clean the aforementioned tanks.

AQS services, Inc. shall not be held responsible for any delays caused by others and adverse weather conditions. These delays shall be considered as out of scope and subject to additional charges.

443 S. Clay Street
Hinsdale, Illinois 60521
Phone (630) 789-3345
Fax (630) 789-2801
aqsservices@comcast.net

11,800.00

If there are any further questions feel free to contact me at 630-789-3345.

Sincerely,

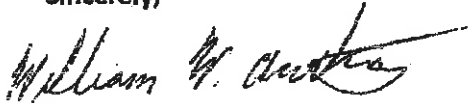
A handwritten signature in black ink that reads "William W. Anthony". The signature is written in a cursive style with a long, sweeping horizontal line extending from the end of the name.

William W. Anthony

AQS Services, Inc.

443 South Clay Street

Hinsdale, Illinois 60521

ESTIMATE

DATE: November 11, 2015



204 Poplar Place North Aurora, IL 60542
 Office; 630 318 1812 direct Fax; 630 844 0091
 Cell; 630 721 7468
 Kris Throm
 City of Darien public works

Estimated By: Virgil McCorkle
 virgilmccorkle@accuratetank.com
 Location: Darien, IL

Ph. 630 353 8105

Terms: Net 30

Fax.

e-mail: kthrom@darienil.gov

Fac. I.D.#

JOB DESCRIPTION

Quote for decommissioning stage 2 vapor recovery system from underground fuel storage tanks.

Notify EPA of plan to decommission

Relieve pressure in tank ullage. Disconnect all vapor processing units.

Seal off below grade vapor piping inside dispenser and at tank (if accessible at tank)

Replace all stage 2 hanging hardware including hoses with conventional hardware and hoses.

Install new filter housings and filters. Install new pressure vacuum vent cap

Remove all stage 2 operating instructions from dispensers.

Conduct pressure decay testing as required by IL. OSFM

Complete required checklist documenting the process and perform final visual/ proper operation of all equipment.

Submit all required forms to IL. EPA.

Costs quoted do not include any repairs that may be needed or replacement of existing equipment other than what is stated above.

ITEMIZED ESTIMATE

As described above	\$ 2070
Quoted price valid thru June 1 st . 2016	
TOTAL ESTIMATED JOB COST	\$ 2070



3947 W. 44th Place, Lyons, Illinois 60534 Ph (708) 579-9289 Fax (708) 579-9287 Petrotech63@comcast.net www.petroleum-technology.com

March 14, 2016

John Carr
Darien Public Works
1041 S. Frontage Road
Darien, IL 60561
email: johncarr@darienil.gov

Stage II Decommissioning

- Remove existing hanging hardware
- Disconnect and cap vapor return line under dispenser
- Install new Standard 3/4" hanging hardware (automatic nozzle, swivel, 12' hose, reconnectable breakaway, whip hose)
- Install inlet adapter assembly with check valve on drop tube
- Replace adapter and fill cap on drop tube
- Perform Pressure Decay Test
- Complete and submit Notice of Intent Form

Total for this scope..... \$ 4,500.00

RESPECTFULLY SUBMITTED BY:



THOMAS J DOHERTY

SIGNATURE OF ACCEPTANCE DATE

METRO

TANK AND PUMP COMPANY

1111 West Dundee Road Wheeling, IL 60090-3936

Phone: (847) 465-4000 Fax: (847) 465-1864

WEBSITE: WWW.METROTANK.COM EMAIL: INFO@METROTANK.COM

Mr. Dan Gombac
City of Darien
1702 Plainfield Road
Darien, IL 60561

April 14, 2016

Re: Stage II Vapor Recovery Decommissioning

METRO Tank and Pump Company is pleased to quote you on the following work at your location. We are a full service company capable of providing you with a complete "TURN-KEY" project from start to finish.

All work will be performed in compliance with the most current guidelines of the Office of the Illinois State Fire Marshal, (OSFM), the Illinois Environmental Protection Agency (I.E.P.A) and OSHA.

STAGE II DECOMMISSIONING SCOPE OF WORK

- ◆ Submit Notice to Decommission letter to IPEA as required.
- ◆ Mobilize to site no sooner than 10 days (directed by IEPA) and initiate safety procedures.
- ◆ Disconnect vacuum-assist system at each fueling point and reprogram dispenser/s to show vapor recovery no longer in service.
- ◆ Isolate and cap the below grade vapor piping at the base of the dispenser.
- ◆ Disconnect the vapor piping at the tank top (if accessible without concrete removal).
- ◆ Seal and cap the dispenser cabinet vapor piping.
- ◆ Replace hanging hardware with (2) sets general hanging hardware.
- ◆ Reinstall the existing pressure/vacuum vent head.
- ◆ Replace (1) overfill droptube with (1) poppeted drop tube.
- ◆ Conduct pressure decay test, perform final visual checks and submit decommission checklist and test results to the IEPA as required.

Price: \$2,950

Not Included in Proposal

1. Any Excavation.
2. Any Concrete work.
3. Electronic calibrations or repairs.
4. Isolation of underground piping to perform Stage II Decay test.
5. Any additional work required if the site does not pass the Pressure Decay Test will be quoted separately.
6. All permits.

Respectfully,
METRO Tank and Pump Company
Hajlije Memiz
Account Executive

Payment Terms: Signed Contract / Purchase Order;
Balance net 20 days.

Accepted By: _____ Print Name: _____ Title: _____ Date: _____

The following Terms and Conditions between *METRO* Tank and Pump Company (hereafter Contractor) and City of Darien (hereafter Purchaser) are affixed and made a part hereof. Please sign in the appropriate place to indicate your acceptance.

TERMS AND CONDITIONS

PAYMENT TERMS

Upon Completion Of Work. All quotes are valid for thirty (30) days. After (30) days, Contractor reserves the right to adjust all prices according to current costs or conditions. All sums to be paid to Contractor under the terms of this contract, unless otherwise specified, in writing, shall be due upon completion of services, delivery of equipment, or installation work to be performed. Any accounts not fully paid within thirty (30) days of date of invoice shall be charged an additional sum of 1 - 1/2 percent per month on balance remaining unpaid. In the event of any liens, suits, or other collection actions of any type, Purchaser shall pay to Contractor, in addition to the principal balance and interest as aforesaid, all reasonable attorney's fees, court costs and other costs of collection. Contractor may suspend the Services under this Agreement, with no penalty and other provisions of this Agreement notwithstanding, at any time until Contractor has been paid in full for all amounts due, including interest charges. Notwithstanding any other provision of this contract, at any time when payment owed to Contractor is not paid within (30) days of date of invoice, Contractor may, without notice, suspend the services under this agreement with no penalty, until Contractor has been paid in full.

WARRANTY

a. Warranty. Contractor provides no warranty for any equipment or material. Purchaser recognizes that the only warranty provided with respect to material and equipment is the manufacturers warranty. Contractor warrants that all labor shall be performed in a good workmanship like manner. All claims for defective workmanship must be made within (90) days.

b. Standard of Care Contractor will perform the Services in a professional manner in accordance with sound consulting practices and procedures. CONTRACTOR MAKES NO OTHER WARRANTY EITHER EXPRESS OR IMPLIED. Specifically, Contractor makes no warranty that material and equipment purchased by Purchaser is either merchantable or fit for the use intended by Purchaser.

TANK REMOVALS

a. Assumptions. Tank removal prices are based upon the following conditions: (a) concrete slab over tank not to exceed 8"; (b) no rebar in concrete; (c) no concrete vaults, removal of underground hold-down slab, saddles or straps; (d) tank to be empty of water, product, sludge, sand or other materials or liquids; (e) no contaminated material or remedial action; (f) no scrap value of tanks; (g) all excavated material to be returned to tank hole; (h) price is based on size of tank specified in quote: if tank is larger, additional costs will be added, if quantity of tanks is less than quoted, no credits; (i) no tank cars; (j) Contractor shall not be held liable for disturbance or damage to nearby tanks or piping; (k) no fiberglass-lined tanks; (l) no double wall tanks; (m) no hazardous material in tank or excavation; (n) above and below ground concrete slab to be put back into excavation; (o) Minimum one day charge for equipment and labor on location, if unable to perform contract job due to unforeseen conditions; (p) E.P.A. regulations require that residue, sediment, and sludge from the tank and sludge generated from the tank cleaning process must be properly disposed of: the charge for sludge handling and disposal, if required, is not included; and (q) no restoration to concrete, asphalt or landscape; sludge or #6 heavy oil.

b. Special Waste. Purchaser agrees that in the event special waste contaminated material is discovered, Contractor shall perform remedial action work, reports, forms and documentation, and Contractor agrees to perform said work in compliance with E.P.A. regulations, as per the attached environmental schedule. Purchaser recognizes and agrees that at no time will Contractor assume title or control of said materials. All payments to Contractor must be made in full prior to the release of any reports.

c. Quantity of Waste. Contractor and the Purchaser agree that the quantity of cubic yards/tons indicated on the waste manifests are subject to verification and acceptance by the landfill and that both parties agree to accept landfill's verification of cubic yards/tons as actual and final amount for purposes of billing. The quantity of cubic yards/tons removed will be determined by the measurement size of the backhoe bucket and/or truck load volume and not by in-ground measurement of excavation. Purchaser agrees to pay Contractor for the quantity of cubic yards/tons billed from the landfill at which the contaminated soil was disposed.

d. Escrow Account. Contaminated soil remediation payment terms will be handled on an escrow basis. Contractor will establish the escrow account. An estimated project cost will be funded by the Purchaser to the account from which Contractor will draw payments. Contractor will proceed with remediation based on monies available in escrow.

TESTING

The price specified in this contract, does not include any soil, liquid, tank, line testing or soil borings which may be required by state, local, and E.P.A. authorities or Purchaser, unless otherwise specified in writing. At Purchaser's request Contractor will obtain tests from an independent testing laboratory or service. The total cost of the test procedure will be billed to Purchaser. Contractor makes no claims as to any tests or results, shall not be held liable for the accuracy of the testing procedures or results, and shall not be held liable or responsible for any action taken due to any test results. All liquid test prices are based upon the accessibility of tank, no excavation is included. Should for any reason the testing is unable to be performed due to customer information inaccuracies or unpreparedness, Purchaser shall be liable for the fee of (1) test.

INDEMNIFICATION

Excepting only such liability as may arise out of the gross negligence of Contractor, the Purchaser agrees to hold harmless, indemnify, and defend Contractor and its officers, directors, agents, employees, contractors, and sub-contractors from and against any and all claims, losses, damages, liability, causes of action (including causes of action for personal injury or death), and costs, including, but not limited to, attorney's fees for counsel of Contractor's choice and other costs of defense, arising out of or in any way connected with:

the existence of contaminated materials on or near the project site. This includes, but is not limited to, the cost of clean-up, removal, hauling, disposal, pumping, reimbursement, reports and any other remedial actions that may be required.

the presence, discharge, release, exposure, or escape of petroleum impacted materials, asbestos or other hazardous substances or contaminants of any kind;

Purchaser's acts, operations, or responsibilities under this Agreement;

or the work of any third party hired by Purchaser to perform work at this site;

Purchaser agrees to hold Contractor harmless for damage to utilities or subterranean structures which are not correctly located by Purchaser;

UTILITIES

Purchaser shall be responsible for designating the location and depth of all utility lines, piping, conduits and subterranean structures within the property lines of the Work Order scope. Contractor will request responsible utilities to locate on and off-site utility lines when necessary and applicable.

CHANGE ORDERS

Additional work requested by Purchaser, other than unit work, will require signed change orders. All other changes in work scope will be billed and/or credited at negotiated prices.

PROJECT DELAYS

Should work be held up and/or delayed by Purchaser, his employees, agents, consultants or other parties under the guidance of Purchaser, Contractor shall receive a minimum of (1) day charge as compensation for said delays. If such delays, Acts of God, or unforeseen delays from suppliers occur, then Contractor shall receive an extension on completion time.

EXCAVATION CLAUSE

All excavation is based upon normal soil and sub-soil conditions. In the event that rocks, vaults, cables, lines, frozen ground, sand, water, contaminated materials, etc. are found, and cause a delay in the progress of the project, and/or an expense is incurred, to repair and/or relocate utilities or lines. Contractor shall not be held responsible or liable, and such costs shall be billed to Purchaser as an extra to this project. Shoring of tank holes or any other structure is not included in contract.

TANK INSTALLATION, REPAIRS AND UPGRADES

Purchaser acknowledges that the signing and acceptance by Contractor and Purchaser does not guarantee work will be completed prior to E.P.A. compliance deadlines.

New tank installations are based upon normal excavation conditions pertaining to weather conditions, concrete, and backfilling. Installation prices are also based upon excavation size being 2 feet greater than the tank in all directions and a 3 foot burial. If, due to unforeseen conditions the tank hole is larger, Purchaser will be billed an extra.

Except only as shall arise through gross negligence of contractor, contractor shall have no responsibility for unforeseen existing equipment malfunctions, piping or conduits.

All fuel for tanks is the responsibility of the Purchaser. Water for tank ballast shall be provided by owner. In the event that any tank shall float, Contractor shall have no liability or responsibility. It shall be the Purchaser's obligation to restore or repair any damage due to tank floating and/or other causes of a release. Contractor shall have no responsibility or obligation due to spills that may occur by fuel suppliers, from accidents, releases and/or negligence.

PERMITS & TAXES

All fees and penalties for permits, registration, or licensing is the responsibility solely of Purchaser. Contractor will assist Purchaser in obtaining permits and will bill Purchaser for all fees and time spent in obtaining permits, unless specifically stated otherwise. Where applicable, sales tax will be billed as a line item unless specifically stated otherwise.

LIABILITIES

Any claims pursuant to this agreement must be in writing, must be within (1) year of work, and may not be for more than the value of the work contracted. No claims may be made in excess of contract work performed.

ATTACHMENTS The attached Contractor proposal/contract, consisting of 3 printed pages and dated 04/14/2016 is hereby incorporated into this agreement.

IN WITNESS WHEREOF, Purchaser and Contractor acknowledge having read and reviewed the above and all pages of this Agreement and agree to be bound by it.

RESOLUTION NO. _____

A RESOLUTION AUTHORIZING THE MAYOR AND CITY CLERK TO ACCEPT A PROPOSAL FROM ACCURATE TANK FOR THE DECOMMISSIONING OF THE STAGE 2 VAPOR RECOVERY SYSTEM, CLEANING AND TELEVISIONING OF THE FUEL TANKS AT THE PUBLIC WORKS FACILITY, 1041 S FRONTAGE ROAD IN AN AMOUNT NOT TO EXCEED \$11,040.

BE IT RESOLVED BY THE CITY COUNCIL OF THE CITY OF DARIEN, DU PAGE COUNTY, ILLINOIS, as follows:

SECTION 1: The City Council of the City of Darien hereby authorizes the Mayor and City Clerk to accept a proposal from Accurate Tank for the decommissioning of the Stage 2 Vapor Recovery System, cleaning and televising of the fuel tanks at the Public Works Facility, 1041 S. Frontage Road in an amount not to exceed \$11,040.00, a copy of which is attached hereto as "**Exhibit A**".

SECTION 2: This Resolution shall be in full force and effect from and after its passage and approval as provided by law.

PASSED BY THE CITY COUNCIL OF THE CITY OF DARIEN, DU PAGE COUNTY, ILLINOIS, this 2nd day of May, 2016.

AYES: _____

NAYS: _____

ABSENT: _____

APPROVED BY THE MAYOR OF THE CITY OF DARIEN, DU PAGE COUNTY, ILLINOIS, this 2nd day of May, 2016.

KATHLEEN MOESLE WEAVER, MAYOR

ATTEST:

JOANNE E. RAGONA, CITY CLERK

APPROVED AS TO FORM

CITY ATTORNEY

1 DAY JOB BOTH TANKS

ESTIMATE

DATE: March 17, 2016



204 Poplar Place North Aurora, IL 60542
 Office; 630 318 1812 direct Fax; 630 844 0091
 Cell; 630 721 7468

Kris Throm
 Water department foreman
 Ph.
 Fax.
 e-mail: kthrom@darienil.gov
 Fac. I.D.#2034534

Estimated By: Virgil McCorkle
 virgilmccorkle@accuratetank.com
 Location: City of Darien
 Terms: Net 30

JOB DESCRIPTION

Quote to empty 2 underground tanks of products and hold on-site; Estimate 2-3000 gallons of gasoline and 4000 gallons of diesel

Completely clean interior of both tanks with pressurized, articulated power washing head (Gama-Jet)

Remove waste from both tanks. Once tanks are deemed completely clean, drop products back into tanks, filtering products during process.

Remove and legally dispose of all waste

ITEMIZED ESTIMATE

As described above	cleaning of 2 tanks. COMPLETED SAME DAY.	\$ 6,500
Waste disposal @ .45 cents per gallon. ESTIMATED 1000 gallons		\$ 450 estimated
Additional pricing for video taping of interior of 2 tanks after cleaning		\$ 315
TOTAL ESTIMATED JOB COST		\$ 7,265

Handwritten in red:
 6,470
 (Circled and crossed out)





ESTIMATE

DATE: November 11, 2015

204 Poplar Place North Aurora, IL 60542
 Office; 630 318 1812 direct Fax; 630 844 0091
 Cell; 630 721 7468
 Kris Throm
 City of Darien public works

Estimated By: Virgil McCorkle
 virgilmccorkle@accuratetank.com
 Location: Darien, IL

Ph. 630 353 8105
 Fax.
 e-mail: kthrom@darienil.gov

Terms: Net 30

Fac. I.D.#

JOB DESCRIPTION

Quote for decommissioning stage 2 vapor recovery system from underground fuel storage tanks.

Notify EPA of plan to decommission

Relieve pressure in tank ullage. Disconnect all vapor processing units.

Seal off below grade vapor piping inside dispenser and at tank (if accessible at tank)

Replace all stage 2 hanging hardware including hoses with conventional hardware and hoses.

Install new filter housings and filters. Install new pressure vacuum vent cap

Remove all stage 2 operating instructions from dispensers.

Conduct pressure decay testing as required by IL. OSFM

Complete required checklist documenting the process and perform final visual/ proper operation of all equipment.

Submit all required forms to IL. EPA.

Costs quoted do not include any repairs that may be needed or replacement of existing equipment other than what is stated above.

ITEMIZED ESTIMATE

As described above	\$ 2070
Quoted price valid thru June 1 st . 2016	
TOTAL ESTIMATED JOB COST	\$ 2070

AGENDA MEMO
Municipal Services Committee
April 25, 2016

ISSUE STATEMENT

Approval of the following resolutions as they relate to the City's Water Meter Replacement Project in an amount not to exceed \$89,900:

1. A resolution to accept a proposal from HD Supply for the purchase of 620 5/8 X 3/4 inch water meters and remote readers in an amount not to exceed \$77,500.
2. A resolution to accept a proposal from HBK Water Meters for the service of flow bench testing the replaced meters in the amount of \$12,400.

BACKGROUND/HISTORY

The purchase of the water meters would allow the department to remove and replace 620 residential water meters. The meters targeted for replacement would be approximately 15 years of age or older. Once the meter is replaced it will be flow tested by an independent agency. The program will take approximately nine months to complete with the City Staff.

The goal of the program is to determine whether the unaccounted water is related to the aged water meters and to further determine whether a city wide meter replacement program needs to be implemented. The 620 meters is the sampling amount that was determined to be the representative sampling for the 9,000 meters the City services. The Staff will provide updates along with a final report to the City Council upon completion of the project. The replaced meters will be returned to the City once they are flow tested and will be declared as surplus property under a separate future agenda.

Below, please find a summary of the competitive quotes for the purchase of 620 residential water meters and the bench flow testing:

Water Meters and Remote Readers

VENDOR	COST
<i>HD Supply</i>	\$77,500
Water Resources	\$84,320

Bench Flow Testing

VENDOR	COST
<i>HBK Water Meter Service</i>	\$12,400
Water Resources	\$13,640

The FY16/17 Budget includes funding for the abovementioned items from the following account:

Water Meters and Remote Readers

April 25, 2016

Page 2

ACCOUNT NUMBER	ACCOUNT DESCRIPTION	FY 16/17 BUDGET	METERS	BENCH FLOW TESTING	TOTAL PROGRAM COST
12-51-4390	WATER DEPRECIATION RANDOM WATER METER REMOVAL AND REPLACEMENT	\$89,900.00	\$77,500.00	\$12,400.00	\$89,900.00

STAFF RECOMMENDATION

Approval of the following resolutions as they relate to the City's Water Meter Replacement Project an amount not to exceed \$89,900:

1. A resolution to accept a proposal from HD Supply for the purchase of 620 5/8 X 3/4 inch water meters and remote readers in an amount not to exceed \$77,500.
2. A resolution to accept a proposal from HBK Water Meters for the service of flow bench testing the replaced meters in the amount of \$12,400.

ALTERNATE DECISION

As directed by Committee

DECISION MODE

This item will be placed on the May 2, 2016 City Council agenda for formal consideration.

RESOLUTION NO. _____

A RESOLUTION AUTHORIZING THE MAYOR AND CITY CLERK TO ACCEPT A PROPOSAL FROM HD SUPPLY FOR THE PURCHASE OF 620 5/8 x 3/4 INCH WATER METERS AND REMOTE READERS IN AN AMOUNT NOT TO EXCEED \$77,500.00

BE IT RESOLVED BY THE CITY COUNCIL OF THE CITY OF DARIEN, DU PAGE COUNTY, ILLINOIS, as follows:

SECTION 1: The City Council of the City of Darien hereby authorizes the Mayor and City Clerk to accept a proposal from HD Supply for the purchase of 620 5/8 x 3/4 inch water meters and remote readers in an amount not to exceed \$77,500 a copy of which is attached hereto as "**Exhibit A**".

SECTION 2: This Resolution shall be in full force and effect from and after its passage and approval as provided by law.

PASSED BY THE CITY COUNCIL OF THE CITY OF DARIEN, DU PAGE COUNTY, ILLINOIS, this 2nd day of May, 2016.

AYES: _____

NAYS: _____

ABSENT: _____

APPROVED BY THE MAYOR OF THE CITY OF DARIEN, DU PAGE COUNTY, ILLINOIS, this 2nd day of May, 2016.

KATHLEEN MOESLE WEAVER, MAYOR

ATTEST:

JOANNE E. RAGONA, CITY CLERK

APPROVED AS TO FORM

CITY ATTORNEY



Bid Proposal for 5/8 x 3/4 Iperls Darien

CUSTOMER	CITY OF DARIEN 1041 SOUTH FRONTAGE ROAD DARIEN, IL 60561 Contact: KRIS	Job 5/8 x 3/4 Iperls Darien Bid Date: 04/11/2016
CONTACT	Sales Representative Joseph Szerszen (M) 630-461-5399 (T) 630-665-1800 (F) 630-665-1887 (E) Joe.Szerszen@hdsupply.com	HD Supply Waterworks 220 South Westgate Dr Carol Stream, IL 60188 (T) 630-665-1800
NOTES		





Bid Proposal for 5/8 x 3/4 Iperls Darien

CITY OF DARIEN
Bid Date: 04/11/2016
HD Supply Bid #: 77102

HD Supply Waterworks
220 South Westgate Dr
Carol Stream, IL 60188
Phone: 630-665-1800
Fax: 630-665-1887

Seq#	Qty	Description	Units	Price	Ext Price
10	620	5/8X3/4 SENSUS IPERL METER USG	EA	117.00	72,540.00
20	620	#S9A AMR TOUCHPAD - BLACK	EA	8.00	4,960.00
40		<p>THE MATERIALS QUOTED ARE BASED ON OUR INTERPRETATION OF THE PLANS AND SPECIFICATIONS. IT IS THE BUYER'S RESPONSIBILITY TO CONFIRM SIZES, QUANTITIES AND CONFORMANCE TO PROJECT SPECIFICATIONS</p> <p>UNLESS OTHERWISE NOTED, THE PRICES QUOTED WILL REMAIN FIRM FOR ORDERS SHIPPED WITHIN 30 DAYS OF QUOTATION DATE. THANK YOU FOR THE OPPORTUNITY TO QUOTE YOUR PROJECT.</p> <p>SINCERELY, JOE SZERSZEN</p>			
50					
60					
70					
80					
90					
100					
110					
120					
130					
140					
150					
160					
170					
180					
190					
				Sub Total	77,500.00
				Tax	0.00
				Total	77,500.00

TERMS AND CONDITIONS OF SALE ("Terms")

1. All references in this document to "Seller" shall include HD Supply, Inc. and / or any parent, subsidiary or affiliate of HD Supply, Inc. (including any division of the foregoing) whether or not performing any or all of the scope hereunder or specifically identified herein. All references to "Buyer" shall include all parent(s), subsidiaries and affiliates of the entity placing the order. Buyer and Seller may be referred to individually as a "Party" and collectively as "Parties".
2. All sales to Buyer are subject to these Terms, which shall prevail over any inconsistent terms of Buyer's purchase order or other documents. Additional or different terms and conditions in any way altering or modifying these Terms are expressly objected to and shall not be binding upon Seller unless specifically accepted in writing by Seller's authorized representative. No modification or alteration of these Terms shall result by Seller's shipment of goods following receipt of Buyer's purchase order, or other documents containing additional, conflicting or inconsistent terms. There are no terms, conditions, understandings, or agreements other than those stated herein, and all prior proposals and negotiations are merged herein. These Terms are binding on the Parties, their successors, and permitted assigns.
3. Prices on Seller website, catalogs or in Seller quotes are subject to change without notice, and all such prices expire and become invalid if not accepted within 10 calendar days from the date of issue, unless otherwise noted by Seller in writing. Price extensions if made are for Buyer's convenience only, and they, as well as any mathematical, stenographic or clerical errors, are not binding on Seller. Prices shown do not include any sales, excise, or other governmental tax or charge payable by Seller to any federal, state or local authority. Any taxes now or hereafter imposed upon sales or shipments will be added to the purchase price, and Buyer shall reimburse Seller for any such tax or provide Seller with an acceptable tax exemption certificate. All prices and other terms provided to Buyer shall be kept confidential except to the extent a Party is required by law to disclose the same.
4. Seller shall not be liable for delay or default in delivery resulting from any cause beyond Seller's reasonable control, including, but not limited to, governmental action, strikes or other labor troubles, fire, damage or destruction of goods, wars (declared or undeclared), acts of terrorism, manufacturers' shortages, availability or timeliness of transportation, materials, fuels, or supplies, and acts of God (such as "Force Majeure Event"). Upon the occurrence of a Force Majeure Event: (a) the time for Seller's performance shall be extended reasonably and the Parties shall adjust all affected dates accordingly; (b) the purchase price shall be adjusted for any increased costs to Seller resulting from such Force Majeure Event; and (c) Buyer shall not be entitled to any other remedy.
5. Seller is a reseller of goods only, and as such does not provide any warranty for the goods it supplies hereunder. Notwithstanding this As-Is limitation, Seller shall pass through to Buyer any transferable manufacturer's standard warranties with respect to goods purchased hereunder. BUYER AND PERSONS CLAIMING THROUGH BUYER SHALL SEEK RECOURSE EXCLUSIVELY FROM MANUFACTURERS IN CONNECTION WITH ANY DEFECTS IN OR FAILURES OF GOODS, AND THIS SHALL BE THE EXCLUSIVE RECOURSE OF BUYER AND PERSONS CLAIMING THROUGH BUYER FOR DEFECTIVE GOODS, WHETHER THE CLAIM OF BUYER OR THE PERSON CLAIMING THROUGH BUYER SHALL SOUND IN CONTRACT, TORT, STRICT LIABILITY, PURSUANT TO STATUTE, OR FOR NEGLIGENCE. BUYER SHALL PASS THESE TERMS TO SUBSEQUENT BUYERS AND USERS OF GOODS. SELLER EXCLUDES AND DISCLAIMS ALL OTHER EXPRESS AND IMPLIED WARRANTIES, INCLUDING, BUT NOT LIMITED TO, ALL IMPLIED WARRANTIES OF MERCHANTABILITY AND FITNESS FOR A PARTICULAR PURPOSE. SELLER ASSUMES NO RESPONSIBILITY WHATSOEVER FOR SELLER'S INTERPRETATION OF PLANS OR SPECIFICATIONS PROVIDED BY BUYER, AND BUYER'S ACCEPTANCE AND USE OF GOODS SUPPLIED HEREUNDER SHALL BE PREMISED ON FINAL APPROVAL BY BUYER OR BY BUYER'S RELIANCE ON ARCHITECTS, ENGINEERS, OR OTHER THIRD PARTIES RATHER THAN ON SELLER'S INTERPRETATION. TO THE EXTENT NOT PROHIBITED BY APPLICABLE LAW, IN NO EVENT, WHETHER IN CONTRACT, WARRANTY, INDEMNITY, TORT (INCLUDING, BUT NOT LIMITED TO, NEGLIGENCE), STRICT LIABILITY OR OTHERWISE, ARISING DIRECTLY OR INDIRECTLY OUT OF THE PERFORMANCE OR BREACH OF THESE TERMS, SHALL SELLER BE LIABLE FOR (a) ANY INCIDENTAL, INDIRECT, PUNITIVE, SPECIAL, CONSEQUENTIAL OR SIMILAR DAMAGES SUCH AS LOSS OF USE, LOST PROFITS, ATTORNEYS' FEES OR DELAY DAMAGES, EVEN IF SUCH DAMAGES WERE FORESEEABLE OR CAUSED BY SELLER'S BREACH OF THIS AGREEMENT, (b) ANY CLAIM THAT PROPERLY IS A CLAIM AGAINST THE MANUFACTURER, OR (c) ANY AMOUNT EXCEEDING THE AMOUNT PAID TO SELLER FOR GOODS FURNISHED TO BUYER WHICH ARE THE SUBJECT OF SUCH CLAIM(S). ALL CLAIMS MUST BE BROUGHT WITHIN ONE YEAR OF ACCRUAL OF A CAUSE OF ACTION.
6. Buyer shall indemnify, defend, and hold Seller its officers, directors, employees and agents harmless from any and all costs (including attorneys' and accountants' fees and expenses), liabilities and damages resulting from or related to any third party (including Buyer's employees) claim, complaint and/or judgment arising from Buyer's use of any goods furnished hereunder, as well as any negligent, intentional, or tortious act or omission of Buyer or any material breach by Buyer of these Terms.
7. When goods are delivered to Buyer in Seller's own vehicles, the F.O.B. point shall be Buyer's designated delivery site. In all other cases the F.O.B. point shall be Seller's store or warehouse and all responsibility and costs of shipping and delivery beyond the applicable F.O.B. point shall be borne by Buyer. Title and risk of loss shall pass to Buyer at the applicable F.O.B. point, which for goods not delivered in Seller's own vehicles shall be when Seller delivers the goods to the common carrier. All claims for shortage of goods or for loss or damage to goods as to which Seller has the risk of loss shall be waived unless Buyer, within 10 calendar days after receipt of the short or damaged shipment, gives Seller written notice fully describing the alleged shortage or damage. Partial shipments are permitted at Seller's discretion.
8. Any change in product specifications, quantities, destinations, shipping schedules, or any other aspect of the scope of goods must be agreed to in writing by Seller, and may result in a price and delivery adjustment by Seller. No credit for goods returned by Buyer shall be given without Seller's written authorization. All returns are subject to a restocking charge.
9. Unless otherwise agreed in writing, payment terms are net 30 days from delivery, payable in United States of America ("U.S.") dollars. Notwithstanding the foregoing, all orders are subject to Seller's continuing approval of Buyer's credit. If Buyer's credit is not approved or becomes unsatisfactory to Seller then Seller, in its sole discretion, may suspend or cancel performance, or require different payment terms, including but not limited to cash on delivery or in advance of shipment. In addition, Seller may in its discretion require an advance deposit of up to 100% of Seller's selling price for any specialty manufactured goods ordered by Buyer hereunder. Payments due hereunder shall be made in the form of cash, check, or money order, or other tender approved in writing by Seller. Seller may, in its sole discretion, apply Buyer's payment against any open charges. Past due accounts bear interest at the lesser of 1.5% per month or the maximum rate permitted by applicable law, continuing after Seller obtains judgment against Buyer. Seller may exercise setoff or recoupment to apply to or satisfy Buyer's outstanding debt. Buyer shall have no right of setoff hereunder, the same being expressly waived hereby.
10. Buyer shall not export or re-export, directly or indirectly, all or any part of the goods or related technology obtained from Seller under these Terms except in accordance with applicable export laws and regulations of the U.S. Further, a Buyer that is a non-U.S. company or citizen shall similarly limit any export or re-export activity to that which would be deemed compliant with U.S. export laws and regulations if performed by a U.S. company or citizen.
11. Buyer shall pay Seller all costs and expenses of collection, suit, or other legal action brought as a result of the commercial relationship between them, including, but not limited to, all actual attorneys' and paralegals' fees, and collection costs, incurred pre-suit, through trial, on appeal, and in any administrative or bankruptcy proceedings. Any cause of action that Seller has against Buyer may be assigned without Buyer's consent to HD Supply, Inc. or to any affiliate, parent or subsidiary of HD Supply, Inc.
12. This Agreement, Buyer's account, and the business relationship between Buyer and Seller shall be governed by and construed in accordance with the laws of Georgia without regard to conflicts of laws rules, and specifically excluding the UN Convention on Contracts for the International Sale of Goods. The Parties agree that any legal action arising under or related to this Agreement shall be brought in Cobb County, Georgia, and any right to object to such venue or to assert the inconvenience of such forum is hereby waived.
13. If Buyer fails to comply with these Terms, Seller may terminate or restrict any order immediately upon notice to Buyer. Buyer certifies that it is solvent and that it will advise Seller immediately if it becomes insolvent. Buyer agrees to send Seller written notice of any changes in the form of ownership of Buyer's business within 5 days of such changes. Buyer and Seller are the only intended beneficiaries of this document, and there are no third party beneficiaries.
14. The invalidity or unenforceability of all or part of these Terms will not affect the validity or enforceability of the other terms. The parties agree to replace any void or unenforceable term with a new term that achieves substantially the same practical and economic effect and is valid and enforceable.
15. The following provisions shall survive termination, cancellation and completed performance of this Agreement as long as necessary to allow the aggrieved party to fully enforce such clauses: 5, 9, 10, 11 and 12.



WATER RESOURCES

April 15, 2016

Kris Throm
City of Darien Public Works
1041 S Frontage Rd.
Darien, IL 60561

We are pleased to submit the following quotation covering Neptune Mach 10 static (no moving parts) water meters for the City of Darien:

<u>Qty.</u>	<u>Description</u>	<u>Price(Ea.)</u>
600	5/8"x3/4" Mach-10 bronze body water meters with Pro Read wall touchpads (Gallons)	\$ 136.00

$$620 \times 136.00 = 84,320$$

Prices are F.O.B. City of Darien. All meters would ship from our Elgin, IL warehouse. We will place an initial order with Neptune for 50-100 meters depending upon anticipated City demand and expect a lead time of 4-5 weeks from the date of order placement. Subsequent orders would be placed as needed by the City. This quotation is valid through December 31, 2016. Thank you for the opportunity to quote on your requirements.

Very truly yours,

Michael D. Pedone

Michael D. Pedone

Water Resources Inc.

MDP/jt

620° x
136° =
84,320° *

Kris Throm

From: Kristofer Throm <wsp_07@yahoo.com>
Sent: Monday, April 18, 2016 8:00 AM
To: Kris Throm
Subject: Fw: Neptune Mach 10 Meter Quote
Attachments: Darien 2016 Mach 10 Meter Quote.docx; ATT00001.htm

----- Forwarded Message -----

From: Mike Pedone <mike.pedone@water-resources.net>
To: "wsp_07@yahoo.com" <wsp_07@yahoo.com>
Sent: Monday, April 18, 2016 7:37 AM
Subject: Neptune Mach 10 Meter Quote

Kris:

Good morning. It looks like you are still having trouble receiving my e-mails. I originally sent this to you Friday around lunchtime at 11:50 AM. Please let me know if you have any questions or issues receiving it.

Thanks.

Mike

Kris:

Good morning. Please see the attached quotation for Neptune Mach 10 water meters per your recent request. Please keep in mind, in addition to the actual product cost on the quote, "hard costs", that there are other additional product features and benefits that represent potentially thousands of additional dollars in "soft costs" that will either benefit the City of Darien by utilizing Neptune's Mach 10 meters or could cost the City additional dollars in true cost of ownership by utilizing the other company's product. These include:

1. Mach 10 has a bronze meter flow tube and will yield salvage revenue to the City of \$3.00-\$5.00 per meter for 5/8" meters at the end of its useful life. The other product is made of plastic and as such has no salvage value.
2. Mach 10 allows electrical continuity to be maintained due to its bronze meter body while the meter is being replaced. Meters made of plastic do not maintain electrical continuity and require the installation of electrical grounding straps at customer locations in order to maintain safety of electrical grounding continuity. These straps may cost \$5.00-\$10.00 per site plus installation time and labor and represent additional costs of ownership and risk for the utility in using these meters.
3. Mach 10 has a higher sampling rate than the other product under consideration. This means that the Mach 10 may be tested for AWWA accuracy on a test bench in its normal mode of operation. The other product being considered samples less frequently and therefore must be bench tested in a special "testing

mode" in order to test on a bench to AWWA standards. The fact that the meter operates in a customer's home in one mode for everyday use and then must be put into a special "testing mode" which increases the sampling rate in order to test properly on a bench could provide a significant hurdle to the City in that the residents who have these meters in their homes might not believe the accuracy of the meter if it must be tested in a different mode than what it operates under in every day working conditions in their homes. Politically speaking this could really incite negative customer reactions to the City if residents feel the meters may potentially overcharge them for water use due to this fact.

4. Mach 10 meters are not susceptible to thread damage if they are cross-threaded during installation and connection to meter couplings like the other meter under consideration. Due to its plastic construction, many customers have expressed frustration with a small percentage of all meters being installed being destroyed by unintentional cross-threading destroying the threads. These meters must then be discarded without being covered under the manufacturer's warranty and then the City must buy more new meters to replace them at its cost.

5. Mach 10 meters are bronze body meters made by Neptune, which is the only North American water meter manufacturer that owns its own on-site foundry. This is key because it gives Neptune complete control over manufacturing cost and quality control. In the water industry, bronze has been and industry standard for over 100 years and is field-proven, durable and connotes quality. Plastic, while acceptable to some utilities, has a connotation of being "cheap" and does not have the reputation for being durable and nearly as field-proven like bronze does. You get what you pay for when you buy bronze meters and the Mach 10 is an example of that.

I hope this additional list of features and benefits helps and please let me know if you have any questions or additional needs.

Thanks and have a great weekend.

Mike Pedone

Water Resources Incorporated

390 Sadler Avenue

Elgin, IL 60120

office - (847) 742-3400

fax - (847) 742-3700

cell - (847) 514-6502

RESOLUTION NO. _____

A RESOLUTION AUTHORIZING THE MAYOR AND CITY CLERK TO ACCEPT A PROPOSAL FROM HBK WATER METERS FOR THE SERVICE OF FLOW BENCH TESTING THE REPLACED METERS IN AN AMOUNT NOT TO EXCEED \$12,400

BE IT RESOLVED BY THE CITY COUNCIL OF THE CITY OF DARIEN, DU PAGE COUNTY, ILLINOIS, as follows:

SECTION 1: The City Council of the City of Darien hereby authorizes the Mayor and City Clerk to accept a proposal from HBK Water Meters for the service of Flow Bench Testing the replaced meters in an amount not to exceed \$12,400 a copy of which is attached hereto as "**Exhibit A**".

SECTION 2: This Resolution shall be in full force and effect from and after its passage and approval as provided by law.

PASSED BY THE CITY COUNCIL OF THE CITY OF DARIEN, DU PAGE COUNTY, ILLINOIS, this 2nd day of May, 2016.

AYES: _____

NAYS: _____

ABSENT: _____

APPROVED BY THE MAYOR OF THE CITY OF DARIEN, DU PAGE COUNTY, ILLINOIS, this 2nd day of May, 2016.

KATHLEEN MOESLE WEAVER, MAYOR

ATTEST:

JOANNE E. RAGONA, CITY CLERK

APPROVED AS TO FORM

CITY ATTORNEY



HBK Water Meter Service, Inc.

EXHIBIT A

P.O. Box 789
Piquette, Illinois 60078-789
(847) 202-4389 Fax (847) 202-9889
www.hbkwater.com

April 20, 2016

City of Darien
1041 S. Frontage Rd.
Darien, Illinois 60561

Attn: Kris Throm

Re: Price Quote for bench testing

Effective: April 20, 2016 through December 31, 2016

620-5/8x3/4 or 3/4" Bench Test @ \$ 20.00ea	\$12,400.00
	<hr/>
Total	\$12,400.00

Thank you for the opportunity to quote your for your project , if you have any questions or concerns please do not hesitate to contact me.

Sincerely,

Sandra G. Grossi
President

AGENDA MEMO
Municipal Services
April 25, 2016

Issue Statement

A resolution authorizing the purchase, installation and wiring of 5 street lights for the Portsmouth Drive Street Light Improvement project with Rags Electric in an amount not to exceed \$29,440.

A motion authorizing the removal, disposal and landscape restoration materials and services for the Portsmouth Drive Street Light project in an amount not to exceed \$6,194.

Background/History

The existing street lights within the City's right of way of the 8300-8400 block of Portsmouth Drive are deteriorating and/or have been removed due to corrosion. The existing lighting system is wired to the adjacent buildings fronting the 12 street lights. The staff has reviewed city records and were unable to locate any agreement regarding the exiting arrangement of street lights placed in a right of way and wired to private buildings. The City's street light system is constructed within right of ways, wired to a Com Ed transformer and assigned an account number. Staff is proposing to remove the existing lighting infrastructure and replace up to five (5) of the City's standard aluminum pole, LED fixtures and rewire to a central controller to be installed within an adjacent easement and be owned and operated by the City. The Municipal Department will assist the vendor with the removals of the existing street light infrastructure and restoration.

The scope of the Portsmouth Avenue Street Light Improvement project includes the following:

1. Removal and Disposal of the Existing Light Poles
2. Removal and Disposal of the Existing Foundations and Wiring
3. Disconnect of the Power Source from the Building
4. Installation of 5 Street Light Foundations
5. Installation of Uni-duct Material and Wiring
6. Installation of 5 25-foot Aluminum Poles with Led Fixtures

Rags Electric is the awarded Street Light Maintenance vendor for FY16/17 and the contract includes unit pricing for abovementioned work and is attached and labeled as Attachment A Pages 1-4. The 2016/17 Budget calls out for the funding for the Street Light Maintenance Program from the following line items:

ACCOUNT NUMBER	ACCOUNT/PRODUCT DESCRIPTION	FY 16/17 BUDGET	TOTAL PROGRAM COST
25-35-4390	CAPITAL IMPROVEMENTS-INFRASTRUCTURE PORTSMOUTH STREET LIGHTING IMPROVEMENT	\$35,634.00	\$ 35,634.00

Below is a cost breakdown as it relates to the project:

DESCRIPTION	UNIT	QUANTITY	UNIT COST	TOTAL COST
STREET LIGHTS -ALUMINUM POLE	EACH	5	\$ 2,850.00	\$ 14,250.00
1.25 UNI DUCT WITH WIRE	LINEAL FOOT	1550	\$ 8.00	\$ 12,400.00
PEDESTAL-COM ED COORDINATION HOOKUP	EACH	1	\$ 950.00	\$ 950.00
TERMINATION OF EXISTING WIRES AT PRIVATE PANEL	HOURLY	20	\$ 92.00	\$ 1,840.00
Rags Electric Total				\$ 29,440.00
DISPOSAL	LUMP SUM	1	\$ 1,000.00	\$ 1,000.00
RESTORATION MATERIAL AND LABOR	LUMP SUM	1	\$ 5,000.00	\$ 5,000.00
CONTINGENCY	LUMP SUM	1	\$ 194.00	\$ 194.00
Total				\$ 6,194.00
TOTAL PROJECT COST				\$ 35,634.00

Staff Recommendation

The Staff recommends approval of the following:

A resolution authorizing the purchase, installation and wiring of 5 street lights for the Portsmouth Drive Street Light Improvement project with Rags Electric in an amount not to exceed \$29,440.

A motion authorizing the removal, disposal and landscape restoration materials and services for the Portsmouth Drive Street Light project in an amount not to exceed \$6,194.

Alternate Consideration

Not approving the project.

Decision Mode

This item will be placed on the May 2, 2016 City Council agenda for formal consideration.

OPTIONS TALLY

2015 - OPTION SUMMARY

Company Name	Option 6 Aluminum Pole (Each)	Option 7 Concrete Pole (Each)	Option 8 Cost for Uniduct (Per Foot)	Option 9 Straightening of Concrete Poles (Each)	Total Option Price
Rags Electric	\$ 2,750.00	\$ 3,150.00	\$ 8.00	\$ 120.00	\$ 6,028.00
Meade Electric	\$ 4,650.00	\$ 5,200.00	\$ 27.25	\$ 1,000.00	\$ 10,877.25
Lyons Electric	\$ 4,000.00	\$ 4,350.00	\$ 17.00	\$ 300.00	\$ 8,667.00

2016 - OPTION SUMMARY

Company Name	Option 6 Aluminum Pole (Each)	Option 7 Concrete Pole (Each)	Option 8 Cost for Uniduct (Per Foot)	Option 9 Straightening of Concrete Poles (Each)	Total Option Price
Rags Electric	\$ 2,850.00	\$ 3,300.00	\$ 8.00	\$ 120.00	\$ 6,278.00
Meade Electric	\$ 4,800.00	\$ 5,400.00	\$ 28.25	\$ 1,040.00	\$ 11,268.25
Lyons Electric	\$ 4,120.00	\$ 4,481.00	\$ 17.51	\$ 309.00	\$ 8,927.51

2017 - OPTION SUMMARY

Company Name	Option 6 Aluminum Pole (Each)	Option 7 Concrete Pole (Each)	Option 8 Cost for Uniduct (Per Foot)	Option 9 Straightening of Concrete Poles (Each)	Total Option Price
Rags Electric	\$ 3,000.00	\$ 3,400.00	\$ 8.00	\$ 1.00	\$ 6,409.00
Meade Electric	\$ 49.75	\$ 5,600.00	\$ 29.00	\$ 1,080.00	\$ 6,758.75
Lyons Electric	\$ 4,244.00	\$ 4,616.00	\$ 18.04	\$ 318.27	\$ 9,196.31

HOURLY RATES

2015 - HOURLY LABOR RATES

Company Name	Journeyman Straight Time	Journeyman Over Time	Helper Straight Time	Helper Over Time	Bucket Truck	Lift Truck	Pickup Truck	Auger/Backhoe	ITEM 2-Hourly Labor Rates
Rag's Electric	\$ 90.00	\$ 115.00	\$ 46.00	\$ 68.00	\$ 20.00	\$ 2.00	\$ 5.00	\$ 3.00	\$ 349.00
Meade Electric	\$ 114.22	\$ 186.22	\$ 65.21	\$ 100.06	\$ 38.00	\$ 47.00	\$ 19.00	\$ 43.00	\$ 612.71
Lyons Electric	\$ 110.00	\$ 160.00	\$ 75.00	\$ 110.00	\$ 55.00	\$ 55.00	\$ 25.00	\$ 60.00	\$ 650.00

2016 - HOURLY LABOR RATES

Company Name	Journeyman Straight Time	Journeyman Over Time	Helper Straight Time	Helper Over Time	Bucket Truck	Lift Truck	Pickup Truck	Auger/Backhoe	ITEM 2-Hourly Labor Rates
Rag's Electric	\$ 92.00	\$ 115.00	\$ 48.00	\$ 70.00	\$ 20.00	\$ 2.00	\$ 5.00	\$ 3.00	\$ 355.00
Meade Electric	\$ 118.78	\$ 193.66	\$ 67.82	\$ 104.06	\$ 39.00	\$ 48.00	\$ 20.00	\$ 44.00	\$ 635.32
Lyons Electric	\$ 113.30	\$ 164.80	\$ 77.25	\$ 113.30	\$ 56.65	\$ 56.65	\$ 25.75	\$ 61.80	\$ 669.50

2017 - HOURLY LABOR RATES

Company Name	Journeyman Straight Time	Journeyman Over Time	Helper Straight Time	Helper Over Time	Bucket Truck	Lift Truck	Pickup Truck	Auger/Backhoe	ITEM 2-Hourly Labor Rates
Rag's Electric	\$ 95.00	\$ 118.00	\$ 51.00	\$ 72.00	\$ 20.00	\$ 2.00	\$ 5.00	\$ 3.00	\$ 366.00
Meade Electric	\$ 123.50	\$ 201.40	\$ 70.50	\$ 108.22	\$ 40.00	\$ 49.00	\$ 21.00	\$ 45.00	\$ 658.62
Lyons Electric	\$ 116.70	\$ 169.74	\$ 79.57	\$ 116.70	\$ 58.35	\$ 58.35	\$ 26.52	\$ 63.65	\$ 689.58

Schedule of Prices for:

STREETLIGHT MAINTENANCE SERVICES PROPOSAL FOR STREET LIGHTS AND POLES LOCATED WITHIN THE RIGHT OF WAYS

Item No.	Items	Unit	Quantity	Unit Price	Total
2016 PRICING					
1	Total cost to repair Street Light Outage	Each	125	140	17,500
	Total cost to supply, remove and replace ballast	Each	20	210	4,200
	Total cost to supply, remove and replace fuse kit	Each	20	40	800
2	Hourly Labor Rates				
	Journeymen - Straight Time	HR	1	92	92
	Journeymen - Over Time	HR	1	115	115
	Helper - Straight Time	HR	1	48	48
	Helper - Over Time	HR	1	70	70
	Bucket Truck	HR	1	20	20
	Lift Truck	HR	1	2	2
	Pickup Truck	HR	1	5	5
	Angle/Backhoe	HR	1	3	3
3	Material Costs - High Pressure Sodium:				
	Brand:				
	250 Watt	Ea.	1	12	12
	400 Watt	Ea.	1	13	13
4	Material Costs - Mercury Vapor:				
	Brand:				
	250 Watt	Ea.	1	12	12
	400 Watt	Ea.	1	13	13
5	Material Costs - Mercury Halide:				
	Brand:				
	250 Watt	Ea.	1	12	12
	400 Watt	Ea.	1	13	13
6-option	Purchase and Installation of Street Light				
	Aluminum pole 25' height with 8' arm -	Ea.	2	2,850	5,700
7-option	Purchase and Installation of Street Light				
	Concrete pole 25' height with 8' arm -	Ea.	2	2,880	6,800
8-option	Unit cost for Undercut (Material and Installation)				
	Material 1 1/2" - KLP-UEP with 3 #5 Copper Wires	Ft.	200	8.00	1,600
9-option	Straightening of Concrete Light Poles	Ea.	10	120	1,200
Part A Sub-Total					38,030.00

NOTE TO ALL CONTRACTORS: The bid tabulations will be based upon Total Cost of items 1, 2, 3, 4, 5, 6, 7, 8 and 9.

Schedule of Prices for:

LIGHT POLE MAINTENANCE SERVICES FOR PRIVATE PROPERTY COMMERCIAL PARKING LOTS

Item No.	Item	Unit	Quantity	Unit Price	Total
2016 PRICING					
1	Total cost to repair Street Light Outage	Ea.	1	140	140
2	Hourly Labor Rates				
	Journeyman - Straight Time	HR	1	92	92
	Journeyman - Over Time	HR	1	115	115
	Helper - Straight Time	HR	1	48	48
	Helper - Over Time	HR	1	70	70
	Bucket Truck	HR	1	20	20
	Lift Truck	HR	1	2	2
	Pickup Truck	HR	1	5	5
	Auger/Backhoe	HR	1	3	3
3	Material Costs - High Pressure Sodium:				
	Brand:				
	100 Watt	Ea.	1	10	10
	150 Watt	Ea.	1	10	10
	200 Watt	Ea.	1	12	12
	250 Watt	Ea.	1	12	12
4	Material Costs - Mercury Vapor:				
	Brand:				
	100 Watt	Ea.	1	10	10
	175 Watt	Ea.	1	12	12
	250 Watt	Ea.	1	12	12
5	Material Costs - Mercury Halide:				
	Brand:				
	160 Watt	Ea.	1	10	10
	175 Watt	Ea.	1	12	12
	250 Watt	Ea.	1	12	12
Part B Sub-Total				607	607

NOTE TO ALL CONTRACTORS: The bid tabulations will be based upon Total Cost of items 1, 2, 3, 4, and 5.

RESOLUTION NO. _____

A RESOLUTION AUTHORIZING THE MAYOR AND CITY CLERK TO ACCEPT A PROPOSAL FOR THE PURCHASE, INSTALLATION, AND WIRING OF 5 STREET LIGHTS FOR THE PORTSMOUTH DRIVE STREET LIGHT IMPROVEMENT PROJECT WITH RAGS ELECTRIC IN AN AMOUNT NOT TO EXCEED \$29,440; MOTION AUTHORIZING THE REMOVAL, DISPOSAL, AND LANDSCAPE RESTORATION MATERIALS AND SERVICES FOR THE PORTSMOUTH DRIVE STREET LIGHT PROJECT IN AN AMOUNT NOT TO EXCEED \$6,194.00

BE IT RESOLVED BY THE CITY COUNCIL OF THE CITY OF DARIEN, DU PAGE COUNTY, ILLINOIS, as follows:

SECTION 1: The City Council of the City of Darien hereby authorizes the Mayor and City Clerk to accept a proposal for the purchase, installation, and wiring of 5 street lights for the Portsmouth Drive Street Light Improvement Project with Rags Electric in an amount not to exceed \$29,440, a copy of which is attached hereto as "Exhibit A"; and a Motion authorizing the removal, disposal, and landscape restoration materials and services for the Portsmouth Drive Street Light Project in an amount not to exceed \$6,194

SECTION 2: This Resolution shall be in full force and effect from and after its passage and approval as provided by law.

PASSED BY THE CITY COUNCIL OF THE CITY OF DARIEN, DU PAGE COUNTY, ILLINOIS, this 2nd day of May, 2016.

AYES: _____

NAYS: _____

ABSENT: _____

APPROVED BY THE MAYOR OF THE CITY OF DARIEN, DU PAGE COUNTY, ILLINOIS, this 2nd day of May, 2016.

KATHLEEN MOESLE WEAVER, MAYOR

ATTEST:

JOANNE E. RAGONA, CITY CLERK

APPROVED AS TO FORM

CITY ATTORNEY

OPTIONS TALLY

2015 - OPTION SUMMARY					
Company Name	Option 6 Aluminum Pole (Each)	Option 7 Concrete Pole (Each)	Option 8 Cost for Uniduct (Per Foot)	Option 9 Straightening of Concrete Poles (Each)	Total Option Price
Rags Electric	\$ 2,750.00	\$ 3,150.00	\$ 8.00	\$ 120.00	\$ 6,028.00
Meade Electric	\$ 4,650.00	\$ 5,200.00	\$ 27.25	\$ 1,000.00	\$ 10,877.25
Lyons Electric	\$ 4,000.00	\$ 4,350.00	\$ 17.00	\$ 300.00	\$ 8,667.00
2016 - OPTION SUMMARY					
Company Name	Option 6 Aluminum Pole (Each)	Option 7 Concrete Pole (Each)	Option 8 Cost for Uniduct (Per Foot)	Option 9 Straightening of Concrete Poles (Each)	Total Option Price
Rags Electric	\$ 2,850.00	\$ 3,300.00	\$ 8.00	\$ 120.00	\$ 6,278.00
Meade Electric	\$ 4,800.00	\$ 5,400.00	\$ 28.25	\$ 1,040.00	\$ 11,268.25
Lyons Electric	\$ 4,120.00	\$ 4,481.00	\$ 17.51	\$ 309.00	\$ 8,927.51
2017 - OPTION SUMMARY					
Company Name	Option 6 Aluminum Pole (Each)	Option 7 Concrete Pole (Each)	Option 8 Cost for Uniduct (Per Foot)	Option 9 Straightening of Concrete Poles (Each)	Total Option Price
Rags Electric	\$ 3,000.00	\$ 3,400.00	\$ 8.00	\$ 1.00	\$ 6,409.00
Meade Electric	\$ 49.75	\$ 5,600.00	\$ 29.00	\$ 1,080.00	\$ 6,758.75
Lyons Electric	\$ 4,244.00	\$ 4,616.00	\$ 18.04	\$ 318.27	\$ 9,196.31

HOURLY RATES

2015 - HOURLY LABOR RATES

Company Name	Journeyman Straight Time	Journeyman Over Time	Helper Straight Time	Helper Over Time	Bucket Truck	Lift Truck	Pickup Truck	Auger/Backhoe	ITEM 2-Hourly Labor Rates
Rag's Electric	\$ 90.00	\$ 115.00	\$ 46.00	\$ 68.00	\$ 20.00	\$ 2.00	\$ 5.00	\$ 3.00	\$ 349.00
Meade Electric	\$ 114.22	\$ 186.22	\$ 65.21	\$ 100.06	\$ 38.00	\$ 47.00	\$ 19.00	\$ 43.00	\$ 612.71
Lyons Electric	\$ 110.00	\$ 160.00	\$ 75.00	\$ 110.00	\$ 55.00	\$ 55.00	\$ 25.00	\$ 60.00	\$ 650.00

2016 - HOURLY LABOR RATES

Company Name	Journeyman Straight Time	Journeyman Over Time	Helper Straight Time	Helper Over Time	Bucket Truck	Lift Truck	Pickup Truck	Auger/Backhoe	ITEM 2-Hourly Labor Rates
Rag's Electric	\$ 92.00	\$ 115.00	\$ 48.00	\$ 70.00	\$ 20.00	\$ 2.00	\$ 5.00	\$ 3.00	\$ 355.00
Meade Electric	\$ 118.78	\$ 193.66	\$ 67.82	\$ 104.06	\$ 39.00	\$ 48.00	\$ 20.00	\$ 44.00	\$ 635.32
Lyons Electric	\$ 113.30	\$ 164.80	\$ 77.25	\$ 113.30	\$ 56.65	\$ 56.65	\$ 25.75	\$ 61.80	\$ 669.50

2017 - HOURLY LABOR RATES

Company Name	Journeyman Straight Time	Journeyman Over Time	Helper Straight Time	Helper Over Time	Bucket Truck	Lift Truck	Pickup Truck	Auger/Backhoe	ITEM 2-Hourly Labor Rates
Rag's Electric	\$ 95.00	\$ 118.00	\$ 51.00	\$ 72.00	\$ 20.00	\$ 2.00	\$ 5.00	\$ 3.00	\$ 366.00
Meade Electric	\$ 123.50	\$ 201.40	\$ 70.50	\$ 108.22	\$ 40.00	\$ 49.00	\$ 21.00	\$ 45.00	\$ 658.62
Lyons Electric	\$ 116.70	\$ 169.74	\$ 79.57	\$ 116.70	\$ 58.35	\$ 58.35	\$ 26.52	\$ 63.65	\$ 689.58

Schedule of Prices for:

STREETLIGHT MAINTENANCE SERVICES PROPOSAL FOR STREET LIGHTS AND POLES LOCATED WITHIN THE RIGHT OF WAYS

Item No.	Item	Unit	Quantity	Unit Price	Total
2016 PRICING					
1	Total cost to repair Street Light Outage	Each	125	140	17,500
	Total cost to supply, remove and replace ballast	Each	20	210	4,200
	Total cost to supply, remove and replace fuse kit	Each	20	40	800
2	Hourly Labor Rates				
	Journeyman - Straight Time	HR	1	92	92
	Journeyman - Over Time	HR	1	115	115
	Helper - Straight Time	HR	1	48	48
	Helper - Over Time	HR	1	70	70
	Bucket Truck	HR	1	20	20
	Lift Truck	HR	1	2	2
	Pickup Truck	HR	1	5	5
	Anger/Sawtooth	HR	1	3	3
3	Material Costs - High Pressure Sodium:				
	Brand:				
	250 Watt	Ea.	1	12	12
	400 Watt	Ea.	1	13	13
4	Material Costs - Mercury Vapor:				
	Brand:				
	250 Watt	Ea.	1	12	12
	400 Watt	Ea.	1	13	13
5	Material Costs - Mercury Halide:				
	Brand:				
	250 Watt	Ea.	1	12	12
	400 Watt	Ea.	1	13	13
6-option	Purchase and Installation of Street Light Aluminum pole 25' height with 8' arm -	Ea.	2	2,850	5,700
7-option	Purchase and Installation of Street Light Concrete pole 25' height with 8' arm -	Ea.	2	2,860	6,600
8-option	Unit cost for Unitcut (Material and Installation) Material 1 1/2" - KLP-USP with 3 #6 Copper Wire	Ft.	200	8.00	1,600
9-option	Straightening of Concrete Light Poles	Ea.	10	120	1,200
Part A Sub-Total					38,030.00

NOTE TO ALL CONTRACTORS: The bid tabulations will be based upon Total Cost of items 1, 2, 3, 4, 5, 6, 7, 8 and 9.

Schedule of Prices for:

**LIGHT POLE MAINTENANCE SERVICES FOR PRIVATE PROPERTY
COMMERCIAL PARKING LOTS**

Item No.	Item	Unit	Quantity	Unit Price	Total
2016 PRICING					
1	Total cost to repair Street Light Outage	Ea.	1	140	140
2	Hourly Labor Rates				
	Journeyman - Straight Time	HR	1	92	92
	Journeyman - Over Time	HR	1	115	115
	Helper - Straight Time	HR	1	48	48
	Helper - Over Time	HR	1	70	70
	Bucket Truck	HR	1	20	20
	Lift Truck	HR	1	2	2
	Pickup Truck	HR	1	5	5
	Auger/Backhoe	HR	1	3	3
3	Material Costs - High Pressure Sodium:				
	Brand:				
	100 Watt	Ea.	1	10	10
	150 Watt	Ea.	1	10	10
	200 Watt	Ea.	1	12	12
	250 Watt	Ea.	1	12	12
4	Material Costs - Mercury Vapor:				
	Brand:				
	100 Watt	Ea.	1	10	10
	175 Watt	Ea.	1	12	12
	250 Watt	Ea.	1	12	12
5	Material Costs - Mercury Halide:				
	Brand:				
	100 Watt	Ea.	1	10	10
	175 Watt	Ea.	1	12	12
	250 Watt	Ea.	1	12	12
Part B Sub-Total				607	607

NOTE TO ALL CONTRACTORS: The bid tabulations will be based upon Total Cost of items 1, 2, 3, 4, and 5.

AGENDA MEMO
MUNICIPAL SERVICES COMMITTEE
MEETING DATE: April 25, 2016

Issue Statement

Class N Liquor License: Consideration of an amendment to the Liquor Code to change the hours liquor can be served for a Class N Liquor License.

Overview/Discussion

Miskatonic Brewing Company, 1000 N. Frontage Road, has requested changing the hours liquor may be served. The following are the current license regulations, Section B provides the permitted hours:

3-3-7-14: CLASS N LICENSE:

(A) A class N license shall authorize the on premises consumption and retail sale of craft beer where the premises is that of a brewing facility. For the purposes of this subsection, "brewing facility" is defined as a place in which the primary business is the manufacturing, packaging, distribution, sale and storage of craft beer produced on the premises in compliance with federal and state laws. The following regulations shall apply to the class N license:

1. No more than a total of fifty thousand (50,000) gallons of beer shall be sold at retail in growlers, cans and/or bottles for off premises consumption per year.
2. All growlers, cans and beers sold at retail for off premises consumption must be properly sealed.
3. Retail sales for off premises consumption and on premises consumption shall be limited to the retail portion of the licensed premises; except, however, on premises consumption may be allowed in other areas of the licensed premises during supervised tours and private events. The retail portion of the licensed premises shall not exceed three thousand (3,000) square feet.
4. Product sampling shall be permitted in accordance with state law, at no charge.
5. Patrons under twenty one (21) years of age shall be allowed on the premises when accompanied by a person twenty one (21) years of age or older; except, however, classes and seminars on alcoholic related subjects shall only be open to patrons twenty one (21) years and older.
6. Live entertainment is restricted to the indoor retail portion of the premises; except, however, live entertainment may be permitted in other indoor areas of the licensed premises during private events.

(B) It shall only be lawful to sell at retail or offer for sale at retail craft beer in conjunction with a class N liquor license for off premises and/or on premises consumption Wednesdays and Thursdays between twelve o'clock (12:00) noon and nine o'clock (9:00) P.M., Fridays and Saturdays between twelve o'clock (12:00) noon and eleven o'clock (11:00) P.M. and Sundays between twelve o'clock (12:00) noon and seven o'clock (7:00) P.M. It shall be unlawful to sell at retail or offer for sale at retail craft beer in conjunction with a class N

liquor license for off premises or on premises consumption on Mondays and Tuesdays. Except, however, private events shall not be restricted to the above hours. For private events it shall be unlawful to sell or serve craft beer between the hours of one o'clock (1:00) A.M. and eleven o'clock (11:00) A.M., except on Saturdays and Sundays when it shall be unlawful for anyone to sell or serve craft beer between the hours of two o'clock (2:00) A.M. and ten o'clock (10:00) A.M. The commissioner may extend the hours of lawful sale or service of craft beer on special occasions such as New Year's Eve.

(C) The number of class N licenses shall be one.

(D) The annual fee for a class N license shall be two thousand dollars (\$2,000.00). (Ord. 0-34-14, 11-3-2014)

Proposed amendment, Section B:

(B) It shall only be lawful to sell at retail or offer for sale at retail craft beer in conjunction with a class N liquor license for off premises and/or on premises consumption between twelve o'clock (12:00) noon and eleven o'clock (11:00) P.M., Sunday through Saturday. Except, however, private events shall not be restricted to the above hours. For private events it shall be unlawful to sell or serve craft beer between the hours of one o'clock (1:00) A.M. and eleven o'clock (11:00) A.M., except on Saturdays and Sundays when it shall be unlawful for anyone to sell or serve craft beer between the hours of two o'clock (2:00) A.M. and ten o'clock (10:00) A.M. The commissioner may extend the hours of lawful sale or service of craft beer on special occasions such as New Year's Eve.

Miskatonic Brewing Company is the only establishment holding a Class N license.

Staff Findings/Recommendations

Staff recommends the Committee make a motion recommending approval of the proposed amendment.

Decision Mode

Municipal Services Committee: April 25, 2016

**MINUTES
CITY OF DARIEN
MUNICIPAL SERVICES COMMITTEE
March 28, 2016**

PRESENT: Joseph Marchese – Chairperson, Alderman Thomas Chlystek, Dan Gombac – Director, Michael Griffith, Senior Planner

ABSENT: Alderman Thomas Belczak, Elizabeth Lahey – Secretary

ESTABLISH QUORUM

Chairperson Marchese called the meeting to order at 6:39 p.m. at the City Hall – City Council Chambers, Darien, Illinois and declared a quorum present.

NEW BUSINESS

- a. Liquor Code Amendment: Consideration of amending the Liquor Code to eliminate open, unused liquor licenses.**

Mr. Dan Gombac, Director reported that this amendment cleans up the Ordinance to eliminate the unused liquor licenses.

Alderman Marchese made a motion and it was seconded by Alderman Chlystek to amend the Liquor Code to eliminate open, unused liquor licenses.

Upon voice vote, the MOTION CARRIED UNANIMOUSLY 2-0. Alderman Belczak was not present.

- b. PZC 2015-20: 8433 Bailey Road, Society of Mount Carmel - Society of the Little Flower - National Shrine to St. Therese: Petitioner requests approval of a final plat of subdivision and a major amendment to an approved PUD, including but not limited to: a new shrine chapel, reconstruction of parking lots and an additional parking lot, a new driveway onto N. Frontage Road and new pedestrian connections and plaza.**

Mr. Michael Griffith, Senior Planner reported that the Planning and Zoning Committee held a public hearing and recommended approval. He reported that the main focus is a new 15,000 square foot chapel with 650 seats. Mr. Griffith reported that the City Engineer looked at the plans and provided minor comments. He reported that there were residents at the public hearing but no comments and a few phone calls from the public.

Mr. Gombac reported that the Illinois Department of Transportation (IDOT) is involved on whatever is in the right of way.

Alderman Chlystek questioned if there are any concerns with traffic.

Mr. Gombac reported that an additional traffic study was not required.

Alderman Chlystek questioned the lighting.

Mr. Gombac reported that there are street lights. He stated that under IDOT they are not required.

Mr. Bruce Aderman, Engineer for the petitioner, reported that they have had preliminary meetings with IDOT and that they were not required to provide a traffic study. He stated that they were limited to the right in and right out which was suggested by IDOT.

Father Colaresi stated that they are trying to address the present overcrowding. He stated that they are not trying to expand the number of people.

Chairperson Marchese questioned if any residents had any feedback.

Mr. Griffith reported that he received a few phone calls but once explained there were no concerns. He stated that the questions were inquiries regarding the golf course. Mr. Griffith reported that no one spoke at the Public Hearing.

Alderman Chlystek questioned the timing of construction.

Ms. Andrea Dolter, Architect, stated that they are anticipating 14 months starting in May.

Mr. Griffith reported that a small portion of the ground sign on Bailey Road will be an electronic message board.

There was no one else wishing to present public comment.

Alderman Chlystek made a motion and it was seconded by Alderman Marchese that based upon the information presented, the request associated with PZC 2015-20 is in conformance with the standards of the Darien City Code and move that the Municipal Services Committee recommend approval of the petition, subject to the following:

- 1. Dimensions on site plan.**
- 2. Sign locations to comply with the Sign Code.**
- 3. The following waivers from the Sign Code:**
 - a. To increase the permitted ground sign area for a religious institution from 32 to 48 square feet.**
 - b. To increase the permitted directional sign area from 4 square feet to 6 square feet and 15 square feet.**
 - c. To increase the permitted directional sign height from 4 feet to 7 feet.**
 - d. To permit an electronic message board sign on the 48 square foot ground sign.**
- 4. Address comments in the letter from Dan Lynch, City Engineer dated March 18, 2016.**
- 5. Address comments in the letter from the Darien-Woodridge Fire Protection District dated February 12, 2016.**

Upon voice vote, THE MOTION CARRIED UNANIMOUSLY 2-0. Alderman Belczak was not present.

- c. Resolution - Approval of a resolution awarding a contract extension to Illinois Central Sweeping for the City of Darien's Annual Street Sweeping Program not to exceed \$35,775.00.**

Mr. Dan Gombac, Director reported that this approval is a contract extension for the 2016 Street Sweeping Services between the City of Darien and Illinois Central Sweeping. He reported that the schedule is within the agenda memo noting three sweeps plus one emergency sweep and a contingency in the amount of \$35,775.00.

There was no one in the audience wishing to present public comment.

Alderman Marchese made a motion and it was seconded by Alderman Chlystek to approve A RESOLUTION AUTHORIZING THE MAYOR AND THE CITY CLERK TO ENTER INTO A CONTRACT EXTENSION FOR THE 2016 STREET SWEEPING SERVICES BETWEEN THE CITY OF DARIEN AND IL CENTRAL SWEEPING IN AN AMOUNT NOT TO EXCEED \$35,775.00.

Upon voice vote, THE MOTION CARRIED UNANIMOUSLY 2-0. Alderman Belczak was not present.

d. Resolution -Approval of a resolution awarding a contract extension to Rag's Electric for the Annual 2016/17 Street Light Maintenance.

Mr. Dan Gombac, Director reported that this approval is to award a contract extension to Rag's Electric for the annual 2016/17 Street Light Maintenance contract. He reported that this is the first extension of a 3-year contract. He further reported that Rag's Electric continues to provide prompt services.

There was no one in the audience wishing to present public comment.

Alderman Chlystek made a motion and it was seconded by Alderman Marchese to approve A RESOLUTION AUTHORIZING THE MAYOR AND THE CITY CLERK TO ENTER INTO A CONTRACT EXTENSION WITH RAG'S ELECTRIC COMPANY FOR THE ANNUAL 2016/17 STREET LIGHT MAINTENANCE. THE PROPOSED CONTRACT EXTENSION WOULD BE THE FIRST EXTENSION, YEAR TWO 2 OF A THREE (3) YEAR CONTRACT.

Upon voice vote, THE MOTION CARRIED UNANIMOUSLY 2-0. Alderman Belczak was not present.

e. Resolution - Approval of a resolution to accept a proposal from Lake Shore Lighting for the purchase of LED Street Light Heads at a cost not to exceed \$187,160.00 as they relate to the City's LED Streetlight Retrofit Project.

f. Resolution - Approval of a resolution to accept the revised unit pricing from Rags Electric in an amount not to exceed \$55,680.00 for the removal of the existing street light heads and the installation of the new LED fixtures as they relate to the City's LED Streetlight Retrofit Project.

Mr. Dan Gombac, Director reported that the two resolutions are related to the City's LED Streetlight Retrofit Project for the purchase of LED Street Light Heads. He reported that staff reached out to the lighting representative and requested a review of the fixture pricing as presented within the street lighting bid tally. He stated that the manufacturer's representative,

Lake Shore Lighting, LLC was able to secure additional discounting provided that all the fixtures are purchased at one time.

Mr. Gombac also reported that staff reached out to the street light vendor, Rag's Electric and negotiated pricing from \$49.00 to \$40.00 per item, for the removal and the replacement.

Mr. Gombac reported that the City applied for two grants. Illinois Energy Grant for \$25,000 and Illinois Department of Commerce and Economic Opportunities for \$105,000. He reported that the City asked for an extension for the \$25,000 grant because the work needed to be completed by April. He stated that the extension was granted to July 31st. Mr. Gombac reported that there is no guarantee for the other grant pending State budget approval. He stated that the City can reapply if and when the DCEO accepts applications.

Alderman Chlystek questioned if the work will be guaranteed.

Mr. Gombac reported that there is a 10 year fixture warranty and a separate 1 year warranty from the vendor who is installing.

Alderman Chlystek questioned if staff has looked into motion detector lighting. He stated that the lights go on and off with motion.

Mr. Gombac stated that he did not believe the lighting was motion sensitive.

There was no one in the audience wishing to present public comment.

Alderman Marchese made a motion and it was seconded by Alderman Chlystek to approve A RESOLUTION AUTHORIZING THE MAYOR AND THE CITY CLERK TO ACCEPT A PROPOSAL FROM LAKE SHORE LIGHTING FOR THE PURCHASE OF LED STREET LIGHT HEADS AT A COST NOT TO EXCEED \$187,160.00 AS THEY RELATE TO THE CITY'S LED STREETLIGHT RETROFIT PROJECT.

And

A RESOLUTION AUTHORIZING THE MAYOR AND THE CITY CLERK TO ACCEPT THE REVISED UNIT PRICING FROM RAG'S ELECTRIC IN AN AMOUNT NOT TO EXCEED \$55,680.00 FOR THE REMOVAL OF THE EXSITING STREET LIGHT HEADS AND THE INSTALLATION OF NEW LED FIXTURES AS THEY RELATE TO THE CITY'S LED STREETLIGHT RETROFIT PROJECT.

Upon voice vote, THE MOTION CARRIED UNANIMOUSLY 2-0. Alderman Belczak was not present.

g. Ordinance - Approval of an ordinance authorizing the disposal of surplus property.

Mr. Dan Gombac, Director reported that this is an ordinance authorizing the disposal of surplus property. He reported that the items would be auctioned or disposed. He stated that there was a complete inventory list in the staff agenda memo.

Alderman Chlystek made a motion and it was seconded by Alderman Marchese to approve an ORDINANCE AUTHORIZING THE SALE OF PERSONAL PROPERTY OWNED BY THE CITY OF DARIEN.

Upon voice vote, THE MOTION CARRIED UNANIMOUSLY 2-0. Alderman Belczak was not present.

h. Minutes-March 17, 2016 Municipal Services Committee

Alderman Chlystek made a motion and it was seconded by Alderman Marchese to approve the March 27, 2016 Municipal Services Committee Meeting Minutes.

Upon voice vote, THE MOTION CARRIED UNANIMOUSLY 2-0. Alderman Belczak was not present.

DIRECTOR'S REPORT

Mr. Gombac reported that he is working closely with Darien Pointe. He reported that the nail salon sign, Pro Nails, went up and that there is a hair-cut business in the works.

Mr. Gombac reported that foundations for the 75th Street Lighting Project 75th are in the process of being poured and the decorative lights have been ordered. He reported on the Plainfield and Bailey Road Project that the construction will begin April 18. The scope of work includes a traffic signal at a City cost of \$100,000 and the replacement of limited water main on Plainfield Road at a cost of approximately \$660,000. The project also includes a resurfacing project from Cass Ave to Manning Road.

NEXT SCHEDULED MEETING

Chairperson Marchese announced that the next regularly scheduled meeting is scheduled for Monday, April 25, 2016 at 6:30 p.m.

ADJOURNMENT

With no further business before the Committee, Alderman Chlystek made a motion and it was seconded by Alderman Marchese to adjourn. Upon voice vote, THE MOTION CARRIED unanimously and the meeting adjourned at 7:25 p.m.

RESPECTFULLY SUBMITTED:

Joseph Marchese
Chairman

ABSENT
Thomas Belczak
Alderman

Thomas Chlystek
Alderman