

CITY OF DARIEN TEMPORARY AMENDMENT TO CITY COUNCIL MEETING RULES FOR COMPLIANCE WITH ILLINOIS OPEN MEETINGS ACT:

- In person attendance at City Council meetings will resume June 1, 2020. All elected officials may elect to participate in a City Council meeting by way of audio or video conferencing. The Council member's absence must be because of personal illness or disability; employment purposes; city business; or a family or other emergency. If a member of the council wishes to attend the meeting by means of a video or audio conference, the member must notify the city clerk of his or her nonattendance as soon as is reasonably possible so that the clerk may make appropriate arrangements.
- The public will be permitted to attend a City Council meeting but the meeting room will be limited to 50 members of the public at one time. The public will be required to maintain social distancing rules and are required to wear a mask while in the building.
- Members of the public physically present must be able to hear all discussion and testimony and all votes of the members of the body. This would mean that members of the public physically present, if more than 50, can be in a different room at City Hall. For example, this can be accomplished by offering a call-in telephone number, a web-based link such as YouTube presenting meeting live or viewing the meeting on cable at City Hall.

Visit the City of Darien [YouTube channel](#) to view the meeting live.

PRE-COUNCIL WORK SESSION — 7:00 P.M.

Agenda of the Regular Meeting

of the City Council of the

CITY OF DARIEN

August 3, 2020

7:30 P.M.

1. Call to Order
2. Pledge of Allegiance
3. Roll Call
4. Declaration of Quorum
5. Questions, Comments and Announcements — **General (This is an opportunity for the public to [make comments or ask questions on any issue](#) – 3 Minute Limit Per Person, **Additional Public Comment Period - Agenda Item 18**)**
6. Approval of Minutes — [July 20, 2020](#)

7. Receiving of Communications
8. Mayor's Report
9. City Clerk's Report
10. City Administrator's Report
11. Department Head Information/Questions
 - A. Police Department
 - B. Municipal Services
12. Treasurer's Report
 - A. Warrant Number — [20-21-07](#)
13. Standing Committee Reports
14. Questions and Comments — **Agenda Related (This is an opportunity for the public to [make comments or ask questions on any item on the Council's Agenda](#) – 3 Minute Limit Per Person)**
15. Old Business
16. Consent Agenda
 - A. Consideration of a Motion to Approve A Resolution Authorizing the [Purchase of Office Equipment from Midwest Office Interiors](#) to Replace Current Equipment in Use by the Police Department Using Department of Justice (DOJ) Award Money in the Amount of \$16,995.71
 - B. Consideration of a Motion to Approve A Resolution Authorizing the [Purchase of \(1\) Dual Purpose Canine \(K9\) Unit and a Four Week Training Class](#) from Northern Michigan K9 Inc. Using Department of Justice Award Money in the Amount of \$11,500.00
 - C. Consideration of a Motion to Approve an Ordinance [Authorizing the Sale of Personal Property Owned by the City of Darien](#)
 - D. Consideration of a Motion to Approve A Motion to Approve the Expenditure of Budgeted Funds to [Purchase Professional Consulting Services from Resource Management](#) in the Amount of \$9,225.00
17. New Business
 - A. Consideration of a Motion to Approve an Ordinance [Amending Section 3-3-7-1\(C\), Class A License and Section 3-3-7-5\(C\) Class E License of the Darien City Code](#)
 - B. Consideration of a Motion to Approve a Resolution Accepting a [Plat of Easement for a Landscape Feature](#) (Northwest Corner of Cass Avenue and Plainfield Road) at 7532 Cass Avenue, PIN# 09-28-402-025

- C. Consideration of a Motion to Approve a Resolution for a [Landscape Feature Agreement and a Dedicated Easement](#) at the Northwest Corner at 7532 Cass Avenue, PIN# 09-28-402-025
 - D. Consideration of a Motion to Approve a [Resolution to Reimburse 7532 Cass Ave LLC](#) in an amount not to Exceed \$22,750.00 for the Construction of the Landscape Feature Located at 7532 Cass Ave
18. Questions, Comments and Announcements — **General (This is an opportunity for the public to [make comments or ask questions on any issue](#) – 3 Minute Limit Per Person)**
19. Adjournment

EXECUTIVE SESSION – PERSONNEL SECTION 2(C)(1) OF THE OPEN MEETINGS ACT

It was moved by Alderman Schauer and seconded by Alderwoman Sullivan to go into Executive Session for the purpose of discussion of Personnel Section 2(C)(1) of the Open Meetings Act at 7:03 P.M.

Roll Call: Ayes: Belczak, Chlystek, Gustafson, Kenny, Schauer, Sullivan, Vaughan

Nays: None

Absent: None

Results: Ayes 7, Nays 0, Absent 0

MOTION DULY CARRIED

It was moved by Alderman Kenny and seconded by Alderman Schauer to adjourn Executive Session.

Roll Call: Ayes: Belczak, Chlystek, Gustafson, Kenny, Schauer, Sullivan, Vaughan

Nays: None

Absent: None

Results: Ayes 7, Nays 0, Absent 0

MOTION DULY CARRIED

Executive Session adjourned at 7:12 P.M.

A WORK SESSION WAS CALLED TO ORDER AT 7:14 P.M. BY MAYOR MARCHESE FOR THE PURPOSE OF REVIEWING ITEMS ON THE JULY 20, 2020 AGENDA WITH THE CITY COUNCIL. THE WORK SESSION ADJOURNED AT 7:22 P.M.

Minutes of the Regular Meeting

of the City Council of the

CITY OF DARIEN

July 20, 2020

7:30 P.M.

1. **CALL TO ORDER**

The regular meeting of the City Council of the City of Darien was called to order at 7:30 P.M. by Mayor Marchese.

2. **PLEDGE OF ALLEGIANCE**

Mayor Marchese led the Council and audience in the Pledge of Allegiance.

3. **ROLL CALL** — The Roll Call of Aldermen by Clerk Ragona was as follows:

Present:	Thomas J. Belczak	Ted V. Schauer
	Thomas M. Chlystek	Mary Coyle Sullivan
	Eric K. Gustafson	Lester Vaughan
	Joseph A. Kenny	

Absent: None

Also in Attendance: Joseph Marchese, Mayor
JoAnne E. Ragona, City Clerk
Michael J. Coren, City Treasurer
Bryon D. Vana, City Administrator
Gregory Thomas, Police Chief
Daniel Gombac, Director of Municipal Services

4. **DECLARATION OF A QUORUM** — There being seven aldermen present, Mayor Marchese declared a quorum.

5. **QUESTIONS, COMMENTS AND ANNOUNCEMENTS – GENERAL**

Mayor Marchese initiated Council discussion regarding the wearing of protective face masks during City meetings. He stated two aldermen expressed concern for wearing masks at all times during City meetings in addition to plexiglass dividers and other safety measures. Council discussion ensued; consensus determined that masks will be worn for all City meetings through the end of September. The subject matter will be revisited in October. All attendees and speakers will also be required to wear masks during City meetings.

James Burke, Chairman of the Board – Darien Chamber of Commerce,...
...announced Darien Dash will be held on August 23, 2020. He noted timing company will be able to maintain social distancing amongst an estimated 250 runners.

...stated business owners were pleased with car show “Cruisin’ on Cass” turnout held at Darien Plaza on Monday evenings; event is driving foot traffic and tourism.

...inquired about ability to host a raffle during “Cruisin’ on Cass” Car Show. Mayor Marchese will meet with Chamber representatives.

6. **APPROVAL OF MINUTES** – June 15, 2020

It was moved by Alderwoman Sullivan and seconded by Alderman Kenny to approve the minutes of the City Council Meeting of June 15, 2020.

Roll Call: Ayes: Belczak, Chlystek, Gustafson, Kenny, Schauer, Sullivan, Vaughan

Nays: None

Absent: None

Results: Ayes 7, Nays 0, Absent 0

MOTION DULY CARRIED

7. **RECEIVING OF COMMUNICATIONS**

Alderwoman Sullivan received...

...communication from several Tara Hill subdivision residents regarding excessive noise concerns. She stated progress has been made; she thanked Police Department and City staff for their responsiveness.

...inquiry regarding short-term rentals/leases; City Planner Hennerfeind and Director Gombac clarified City requirements.

...received communication from Pinehurst subdivision resident regarding need for fence along Bailey Road to discourage residents from walking their pets on Carriage Greens Golf course. She encouraged residents to use alternate walking paths for their own safety. Alderwoman Sullivan will be meeting with Carriage Greens Country Club to determine best way to communicate course path is for golf use only.

Alderman Kenny received communication from Bonnie Kucera, Norman Courts, regarding phone solicitation for Police Department donations. Chief Thomas stated Police Department does not endorse this type of solicitation.

Alderman Gustafson received communication regarding fumes coming from Home Depot generator. Director Gombac will contract Home Depot Store Manager.

Alderman Chylstek received communication from...

...Mickey Magnifico, Brookdale Apartments, regarding an insurance concern; issue was referred to DuPage County.

...Jerry Leganski, 8000 block of Farmingdale Drive regarding a power outage; Administrator Vana communicated with ComEd.

8. **MAYORS REPORT**

Mayor Marchese expressed his condolences regarding the passing of Jim Addington, Westmont Trustee & former Mayor, and Lion.

A. DENEEN M. RUFFOLO – DARIEN LIONS CLUB HUMANITARIAN OF THE YEAR

Mayor Marchese read into the record a proclamation declaring July 24, 2020 as Deneen Ruffolo Day in the City of Darien.

Greg Ruffolo, expressed how proud he was of his wife; he thanked her for making a difference in the lives of thousands by providing gifts to countless children during the Lions Club Food Basket Drive.

John Pearson, Darien Lions Club President, presented Deneen with a replica brick that will be placed in the Lions Foundation brick patio at Darien Community Park.

Deneen thanked the Darien Lions Club for the award and City of Darien for the proclamation. Deneen commented she was raised to give back to the community and did not give a second thought to volunteering to take over the gift portion of the food baskets. She thanked the volunteers and the many others that are deserving of the award. Deneen stated “We live in a great City, a very giving City, hope and pray it continues that way.”

Mayor Marchese noted Deneen was receiving a small token for the recognition she deserves; he thanked her for making so many children happy at Christmas. Alderman Kenny commented he became a better realtor with Deneen residing in the office next to his.

B. CONSIDERATION OF A MOTION TO APPROVE THE APPOINTMENT OF CLAUDIA BOROWSKI AND RYAN GRACE TO THE ENVIRONMENTAL COMMITTEE

It was moved by Alderman Vaughan and seconded by Alderman Belczak to approve the motion as presented.

Roll Call: Ayes: Belczak, Chlystek, Gustafson, Kenny, Schauer, Sullivan, Vaughan

Nays: None

Absent: None

Results: Ayes 7, Nays 0, Absent 0

MOTION DULY CARRIED

Clerk Ragona administered the Oath of Office to Claudia Borowski and Ryan Grace.

C. CONSIDERATION OF A MOTION TO APPROVE THE REAPPOINTMENT OF DEB HARDTKE, ALLAN JACKIMEK, AND ARLETA PEKNIK TO THE ENVIRONMENTAL COMMITTEE

It was moved by Alderman Schauer and seconded by Alderwoman Sullivan to approve the motion as presented.

Roll Call: Ayes: Belczak, Chlystek, Gustafson, Kenny, Schauer, Sullivan, Vaughan

Nays: None

Absent: None

Results: Ayes 7, Nays 0, Absent 0

MOTION DULY CARRIED

Clerk Ragona administered the Oath of Office to Deb Hardtke, Allan Jackimek, and Arleta Peknik.

D. CONSIDERATION OF A MOTION TO APPROVE THE REAPPOINTMENT OF JOHN J. ARMELLINO TO THE BOARD OF FIRE AND POLICE COMMISSIONERS

It was moved by Alderman Kenny and seconded by Alderman Vaughan to approve the motion as presented.

Roll Call: Ayes: Belczak, Chlystek, Gustafson, Kenny, Schauer, Sullivan, Vaughan

Nays: None

Absent: None

Results: Ayes 7, Nays 0, Absent 0

MOTION DULY CARRIED

Clerk Ragona administered the Oath of Office to John J. Armellino.

E. CONSIDERATION OF A MOTION TO APPROVE THE REAPPOINTMENT OF JEFF MAY TO THE POLICE PENSION BOARD

It was moved by Alderman Schauer and seconded by Alderman Belczak to approve the motion as presented.

Roll Call: Ayes: Belczak, Chlystek, Gustafson, Kenny, Schauer, Sullivan, Vaughan

Nays: None

Absent: None

Results: Ayes 7, Nays 0, Absent 0

MOTION DULY CARRIED

Clerk Ragona administered the Oath of Office to Jeff May.

F. METRO STRATEGIES – QUARTERLY REPORT

Jennie Vana, Vice President of Communications, and Kaitlin Cernak, Communications Manager, with Metro Strategies distributed handouts. They provided quarterly report, which included update of online survey results, the revamping of Direct Connect eNews, implementation of Nextdoor account, and the metrics/measurements across the City's communication channels. Ms. Vana and Ms. Cernak addressed Council questions.

9. **CITY CLERK'S REPORT**

There was no report.

10. **CITY ADMINISTRATOR’S REPORT**

There was no report.

11. **DEPARTMENT HEAD INFORMATION/QUESTIONS**

A. POLICE DEPARTMENT

Chief Thomas...

...reiterated that solicitation to “support police” is not endorsed by Darien Police Department.

...shared credit card scam with cards issued by Illinois Department of Employment Security (IDES); he advised residents to report fraud to Police Department and IDES.

...reviewed monthly reporting issues; noted better reporting to follow.

...addressed Council questions.

B. MUNICIPAL SERVICES – NO REPORT

Director Gombac addressed Council inquiry regarding commercial property.

12. **TREASURER’S REPORT**

A. WARRANT NUMBER 20-21-05

It was moved by Alderwoman Sullivan and seconded by Alderman Kenny to approve payment of Warrant Number 20-21-05 in the amount of \$132,195.24 from the enumerated funds, and \$524,007.02 from payroll funds for the periods ending 06/18/20 and 07/02/20 for a total to be approved of \$656,202.26.

Roll Call: Ayes: Belczak, Chlystek, Gustafson, Kenny, Schauer, Sullivan, Vaughan

Nays: None

Absent: None

Results: Ayes 7, Nays 0, Absent 0

MOTION DULY CARRIED

B. WARRANT NUMBER 20-21-06

It was moved by Alderman Vaughan and seconded by Alderman Schauer to approve payment of Warrant Number 20-21-06 in the amount of \$1,145,193.20 from the enumerated funds, and \$261,355.39 from payroll funds for the period ending 07/16/20 for a total to be approved of \$1,406,548.59.

Roll Call: Ayes: Belczak, Chylstek, Gustafson, Kenny, Schauer, Sullivan, Vaughan

 Nays: None

 Absent: None

 Results: Ayes 7, Nays 0, Absent 0

MOTION DULY CARRIED

13. **STANDING COMMITTEE REPORTS**

Administrative/Finance Committee – Chairwoman Sullivan announced the next meeting of the Administrative/Finance Committee is scheduled for August 3, 2020 at 6:00 P.M. in the City Hall Conference Room.

Municipal Services Committee – Chairman Belczak stated the minutes of the June 15, 2020 meeting were approved and submitted to the Clerk’s Office. He announced the next meeting of the Municipal Services Committee is scheduled for August 24, 2020 at 7:00 P.M.

Police Committee – Chairman Kenny stated the minutes of the June 15, 2020 meeting were approved and submitted to the Clerk’s Office. He announced the next meeting of the Police Committee is scheduled for August 17, 2020 at 6:00 P.M. in the Police Department Training Room.

14. **QUESTIONS AND COMMENTS – AGENDA RELATED**

Alderman Chylstek voiced concern regarding Darien Dash. Council discussion ensued. It was noted that the Darien Dash could be cancelled if COVID conditions worsened.

15. **OLD BUSINESS**

There was no Old Business.

16. **CONSENT AGENDA**

It was moved by Alderman Belczak and seconded by Alderman Vaughan to approve by Omnibus Vote the following items on the Consent Agenda:

A. ORDINANCE NO. O-12-20 AN ORDINANCE REPLACING TITLE 8 (POLICE REGULATIONS) CHAPTER 20 (DRUG PARAPHERNALIA) OF THE CITY OF DARIEN CITY CODE

B. ORDINANCE NO. O-13-20 AN ORDINANCE REPLACING TITLE 8, POLICE REGULATIONS, CHAPTER 7 CANNABIS REGULATIONS OF THE CITY OF DARIEN CITY CODE

Roll Call: Ayes: Belczak, Chlystek, Gustafson, Kenny, Schauer, Sullivan, Vaughan

Nays: None

Absent: None

Results: Ayes 7, Nays 0, Absent 0

MOTION DULY CARRIED

17. **NEW BUSINESS**

A. CONSIDERATION OF A MOTION TO APPROVE THE DARIEN CHAMBER OF COMMERCE 20TH ANNUAL DARIEN DASH, A 10K RUN/A 5K RUN/1MILE WALK, ON AUGUST 23, 2020 BEGINNING AT 8:00 A.M. AND AUTHORIZE THE CHIEF OF POLICE TO FINALIZE THE DETAILS OF THIS EVENT WITH THE CHAMBER OF COMMERCE

It was moved by Alderman Belczak and seconded by Alderman Schauer to approve the motion as presented.

Alderman Kenny voiced his concern with ability to stage participants.

Roll Call: Ayes: Belczak, Gustafson, Schauer, Sullivan
Nays: Chlystek, Kenny, Vaughan
Absent: None

Results: Ayes 4, Nays 3, Absent 0

MOTION DULY CARRIED

B. CONSIDERATION OF A MOTION TO APPROVE THE USE OF THE RIGHT HALF OF THE FOLLOWING STREETS FOR THE *DARIEN DASH*: THE 5K AND 10K COURSE:

START ON IRONWOOD AVENUE AT THE DARIEN SWIM AND RECREATION CLUB AND HEAD NORTH TO 69TH STREET. TURN EAST ON TO 69TH STREET TO RICHMOND AVENUE; TURN SOUTH ON RICHMOND AVENUE TO 70TH STREET; TURN EAST ON 70TH STREET TO BENTLEY AVENUE; TURN NORTH ON BENTLEY AVENUE TO 69TH STREET; TURN EAST ON 69TH STREET TO CLARENDON HILLS ROAD; TURN SOUTH ON CLARENDON HILLS ROAD TO 70TH STREET; TURN WEST ON 70TH STREET TO BENTLEY AVENUE; TURN SOUTH ON BENTLEY AVENUE TO MAPLE LANE; TURN EAST ON MAPLE LANE TO CLARENDON HILLS ROAD; TURN SOUTH ON CLARENDON HILLS ROAD TO 71ST STREET; TURN WEST 71ST STREET TO BENTLEY AVENUE; TURN NORTH ON BENTLEY AVENUE TO MAPLE LANE; TURN WEST ONTO MAPLE LANE TO RICHMOND AVENUE; TURN SOUTH ON RICHMOND AVENUE TO 71ST STREET; TURN WEST ON 71ST STREET TO BEECHNUT LANE; TURN NORTH ON BEECHNUT LANE TO IRONWOOD AVENUE; TURN EAST ON IRONWOOD AVENUE TO START/FINISH LINE

1-MILE COURSE:

START ON IRONWOOD AVENUE AT THE DARIEN SWIM AND RECREATION CLUB AND HEAD NORTH TO 69TH STREET. TURN EAST ON TO 69TH STREET TO SIERRA DRIVE; TURN SOUTH ON SIERRA DRIVE TO 71ST STREET; TURN WEST ON 71ST STREET TO BEECHNUT LANE; TURN NORTH ON BEECHNUT LANE TO IRONWOOD AVENUE; TURN WEST ON IRONWOOD AVENUE TO START/FINISH LINE

It was moved by Alderman Schauer and seconded by Alderman Belczak to approve the motion as presented.

Roll Call: Ayes: Belczak, Gustafson, Schauer, Sullivan
Nays: Chlystek, Kenny, Vaughan
Absent: None

Results: Ayes 4, Nays 3, Absent 0

MOTION DULY CARRIED

C. CONSIDERATION OF A MOTION TO APPROVE AN ORDINANCE GRANTING A VARIATION FROM SECTION 5A-5-9-8(B) (PZC 2020-06 8131 LEMONT ROAD)

It was moved by Alderman Belczak and seconded by Alderman Vaughan to approve the motion as presented.

Alderman Belczak noted Municipal Services unanimously recommended the zoning variation.

ORDINANCE NO. O-14-20 AN ORDINANCE GRANTING A VARIATION FROM SECTION 5A-5-9-8(B) (PZC 2020-06 8131 LEMONT ROAD)

Roll Call: Ayes: Belczak, Chlystek, Gustafson, Kenny, Schauer, Sullivan, Vaughan
Nays: None
Absent: None

Results: Ayes 7, Nays 0, Absent 0

MOTION DULY CARRIED

D. CONSIDERATION OF A MOTION TO APPROVE A RESOLUTION APPROVING AN INTERGOVERNMENTAL AGREEMENT BETWEEN THE CITY OF DARIEN AND DUPAGE COUNTY FOR PARTICIPATION IN DUPAGE COUNTY LOCAL GOVERNMENT COVID-19 REIMBURSEMENT PROGRAM

It was moved by Alderwoman Sullivan and seconded by Alderman Chlystek to approve the motion as presented.

Mayor Marchese provided background information and program details; he addressed Council questions.

RESOLUTION NO. R-37-20

A RESOLUTION APPROVING AN INTERGOVERNMENTAL AGREEMENT BETWEEN THE CITY OF DARIEN AND DUPAGE COUNTY FOR PARTICIPATION IN DUPAGE COUNTY LOCAL GOVERNMENT COVID-19 REIMBURSEMENT PROGRAM

Roll Call: Ayes: Belczak, Chlystek, Gustafson, Kenny, Schauer, Sullivan, Vaughan

Nays: None

Absent: None

Results: Ayes 7, Nays 0, Absent 0

MOTION DULY CARRIED

E. CONSIDERATION OF A MOTION TO DIRECT STAFF TO PROCEED WITH A LANDSCAPE ENHANCEMENT PROJECT AND EASEMENT AGREEMENT FOR THE NORTHWEST CORNER AT 7532 CASS AVENUE, PIN# 09-28-402-025

It was moved by Alderman Kenny and seconded by Alderwoman Sullivan to approve the motion as presented.

Alderman Belczak inquired regarding signage and beautification details. Director Gombac displayed landscape rendering. Council discussion ensued. Administrator Vana noted once information is formalized, the project will be brought back to Council for formal vote.

Roll Call: Ayes: Chlystek, Kenny, Schauer, Sullivan, Vaughan

Nays: Belczak, Gustafson

Absent: None

Results: Ayes 5, Nays 2, Absent 0

MOTION DULY CARRIED

18. **QUESTIONS, COMMENTS AND ANNOUNCEMENTS – GENERAL**

Alderman Chlystek...

...inquired about Facebook posting that highlighted an elected County official; Administrator Vana explained posting was made in error.

...voiced safety concern with the corner of Frontage Road & Cass Avenue; he expressed need for DuPage County traffic study. Council discussion ensued.

Sylvia McIvor shared her communication with Chief Thomas regarding family member being recipient of SCAM involving IDES card fraud; she explained and encouraged residents to sign up for informed delivery through United States Postal Service (USPS), which is available on the USPS website.

Mayor Marchese commented he joined Danny Tischler and the Cancer Smashers in installing 4 duck houses in different Darien Park District ponds. He thanked Rob Sarocco, Darien Park District Board of Park Commissioners President, for working with the Cancer Smashers in building and erecting the duck houses.

19. **ADJOURNMENT**

There being no further business to come before the City Council, it was moved by Alderman Schauer and seconded by Alderman Vaughan to adjourn the City Council meeting.

VIA VOICE VOTE – MOTION DULY CARRIED

The City Council meeting adjourned at 9:35 P.M.

Mayor

City Clerk

All supporting documentation and report originals of these minutes are on file in the Office of the City Clerk under File Number 7-20-20. Minutes of 7-20-20 CCM.



CITY OF DARIEN

**EXPENDITURE APPROVAL LIST
FOR CITY COUNCIL MEETING ON
August 3, 2020**

Approval is hereby given to have the City Treasurer of Darien, Illinois pay to the officers, employees, independent contractors, vendors, and other providers of goods and services in the indicated amounts as set forth.

A summary indicating the source of funds used to pay the above is as follows:

General Fund				\$75,348.78
Water Fund				\$14,006.32
Motor Fuel Tax Fund				\$1,513.84
Water Depreciation Fund				\$2,179.00
Special Service Area Tax Fund				
E-Citation Fund				
Capital Improvement Fund				
State Drug Forfeiture Fund				
Federal Equitable Sharing Fund				
DUI Technology Fund				
			Subtotal:	<u>\$93,047.94</u>
General Fund Payroll	07/30/20	\$	223,774.22	
Water Fund Payroll	07/30/20	\$	24,856.95	
		Subtotal:	\$	<u>248,631.17</u>
Total to be Approved by City Council:				<u>\$ 341,679.11</u>

Approvals:

Joseph A. Marchese, Mayor

JoAnne E. Ragona, City Clerk

Michael J. Coren, Treasurer

Bryon D. Vana, City Administrator

CITY OF DARIEN
Expenditure Journal
General Fund
Administration
From 7/21/2020 Through 8/3/2020

Vendor Name	Invoice Description	Session ID	Acct Code	Acct Title	Dept Amount
AIS	DATA SERVICES- AUG 2020	AP080320	4325	Consulting/Professional	5,130.26
AIS	MONTHLY BACK-UP SERVICE - AUG 2020	AP080320	4325	Consulting/Professional	1,300.00
AIS	CLOUD HOSTING- AUG 2020	AP080320	4325	Consulting/Professional	20.00
AIS	EXCEEDED BLOCK HOURS- JUNE 2020	AP080320	4325	Consulting/Professional	105.00
CALL ONE, INC.	CITY TELEPHONE BILL	AP080320	4267	Telephone	1,542.91
COMCAST BUSINESS	CABLE BILL FOR CITY HALL	AP080320	4271	Utilities (Elec,Gas,Wtr,Sewer)	32.77
DUPAGE COUNTY PUBLIC WORKS	SEWER BILL- CITY HALL	AP080320	4271	Utilities (Elec,Gas,Wtr,Sewer)	109.71
GOVTEMPSUSA LLC	VANA -(7-5-20)	AP080320	4325	Consulting/Professional	3,415.38
GOVTEMPSUSA LLC	VANA -(7-12-20)	AP080320	4325	Consulting/Professional	3,415.38
IMPACT NETWORKING, LLC	KONICA COPIER LEASE (7-18-20 thru 8-17-20)	AP080320	4225	Maintenance - Equipment	150.00
METRO STRATEGIES	ADDL SERVICES RELATED TO COVID-19	AP080320	4239	Public Relations	4,878.00
NICOR GAS	NICOR 82541110001 1702 PLAINFIELD RD DARIEN	AP080320	4271	Utilities (Elec,Gas,Wtr,Sewer)	121.95
OFFICE DEPOT	OFFICE SUPPLIES	AP080320	4253	Supplies - Office	77.18
OFFICE DEPOT	PENS	AP080320-3	4253	Supplies - Office	19.69
OFFICE DEPOT	PENS	AP080320-4	4253	Supplies - Office	19.49
OFFICE DEPOT	PENS	APVOID080320-3	4253	Supplies - Office	(19.69)
QUADIENT FINANCE USA INC	INK & LABELS FOR POSTAGE MACHINE	AP080320	4253	Supplies - Office	125.00
				Total Administration	20,443.03

CITY OF DARIEN
Expenditure Journal
General Fund
City Council
From 7/21/2020 Through 8/3/2020

<u>Vendor Name</u>	<u>Invoice Description</u>	<u>Session ID</u>	<u>Acct Code</u>	<u>Acct Title</u>	<u>Dept Amount</u>
DUPAGE MAYORS MANAGERS CONF.	220-2021 CONFERENCE MEMBERSHIP DUES	AP080320	4213	Dues and Subscriptions	9,747.58
				Total City Council	9,747.58

CITY OF DARIEN
Expenditure Journal
General Fund
Community Development
From 7/21/2020 Through 8/3/2020

<u>Vendor Name</u>	<u>Invoice Description</u>	<u>Session ID</u>	<u>Acct Code</u>	<u>Acct Title</u>	<u>Dept Amount</u>
ODELSON & STERK LTD	LEGAL FEES- JUNE 2020	AP080320	4219	Liability Insurance	2,602.00
QUADIENT FINANCE USA INC	INK & LABELS FOR POSTAGE MACHINE	AP080320	4253	Supplies - Office	20.00
				Total Community Development	2,622.00

CITY OF DARIEN
Expenditure Journal
General Fund
Public Works, Streets
From 7/21/2020 Through 8/3/2020

Vendor Name	Invoice Description	Session ID	Acct Code	Acct Title	Dept Amount
ALARM DETECTION SYSTEMS INC	ALARM DETECTION-PUBLIC WORKS	AP080320	4223	Maintenance - Building	203.43
CARLS SEPTIC SERVICE, INC.	SEPTIC HAULING	AP080320	4223	Maintenance - Building	125.00
CASE LOTS, INC.	SANITIZERS	AP080320	4219	Liability Insurance	102.95
CASE LOTS, INC.	SANITIZERS AND BUILDING SUPPLIES	AP080320	4223	Maintenance - Building	172.20
CENTRAL SOD FARMS	BLUEGRASS FOR RESTORATIONS	AP080320	4257	Supplies - Other	28.00
CENTRAL SOD FARMS	BLUEGRASS FOR RESTORATIONS	AP080320	4257	Supplies - Other	298.00
CENTRAL SOD FARMS	PALLET RETURNED	AP080320	4257	Supplies - Other	(10.00)
CINTAS #769	MATT RENTAL - PUBLIC WORKS	AP080320	4223	Maintenance - Building	50.87
CINTAS #769	MATT RENTAL - POLICE DEPT	AP080320	4223	Maintenance - Building	49.70
COM ED	COM ED 0788310001 1041 S FRONTAGE RD DARIEN	AP080320	4271	Utilities (Elec,Gas,Wtr,Sewer)	56.09
HINSDALE NURSERIES INC.	CREDIT ON VOIDED CK 055325 (DUPL PAYMENT)	APCREDIT072...	4374	Drainage Projects	(121.98)
ILLINI POWER PRODUCTS	GENERATOR CITY HALL	AP080320	4223	Maintenance - Building	1,390.00
ILLINI POWER PRODUCTS	GENERATOR FOR POLICE DEPT	AP080320	4223	Maintenance - Building	1,415.00
INDEPENDENCE TOWING & RECOVERY	TOW FOR #109 BREAK-DOWN	AP080320	4229	Maintenance - Vehicles	625.00
JX ENTERPRISES INC	REPAIR PARTS FOR TRUCK #101	AP080320	4229	Maintenance - Vehicles	998.99
LINDCO EQUIPMENT SALES, INC.	REPAIRS FOR #109	AP080320	4229	Maintenance - Vehicles	900.25
LORCHEM TECHNOLOGIES INC	EQUIPMENT REPAIR	AP080320	4225	Maintenance - Equipment	267.62
MID-TOWN ACQUISITION -RELADYNE	VEHICLE MAINTENANCE	AP080320	4229	Maintenance - Vehicles	1,846.70
POMP'S TIRE SERVICE, INC.	TIRES	AP080320	4225	Maintenance - Equipment	1,636.52
QUADIENT FINANCE USA INC	INK & LABELS FOR POSTAGE MACHINE	AP080320	4253	Supplies - Office	9.00

CITY OF DARIEN
Expenditure Journal
General Fund
Public Works, Streets
From 7/21/2020 Through 8/3/2020

Vendor Name	Invoice Description	Session ID	Acct Code	Acct Title	Dept Amount
RAGS ELECTRIC	BATHROOM LIGHTS FOR POLICE DEPT	AP080320	4223	Maintenance - Building	239.50
SEBERT LANDSCAPING	75TH ST PLANTERS	AP080320	4350	Forestry	4,741.66
SEBERT LANDSCAPING	ENTRANCE WAY SIGNS	AP080320	4350	Forestry	985.00
SEBERT LANDSCAPING	CLOCK TOWER	AP080320	4350	Forestry	2,635.98
SEBERT LANDSCAPING	CITY LANDSCAPE MAINTENANCE - MAY 2020	AP080320	4350	Forestry	2,612.01
SEBERT LANDSCAPING	75TH STREET PLANTERS	AP080320	4350	Forestry	4,741.66
SEBERT LANDSCAPING	CITY ENTRANCE WAY SIGNS	AP080320	4350	Forestry	985.00
SEBERT LANDSCAPING	CLOCK TOWER	AP080320	4350	Forestry	2,635.98
SEBERT LANDSCAPING	CITY COMPLEX	AP080320	4350	Forestry	2,612.01
STATE CHEMICAL SOLUTIONS	DISINFECTANTS	AP080320	4223	Maintenance - Building	193.21
STATE CHEMICAL SOLUTIONS	DISINFECTANTS	APVOID080320	4223	Maintenance - Building	(193.21)
STATE INDUSTRIAL PRODUCTS	SEPTIC	AP080320	4223	Maintenance - Building	335.68
STATE INDUSTRIAL PRODUCTS	SEPTIC	AP080320	4223	Maintenance - Building	404.57
STATE INDUSTRIAL PRODUCTS	DISINFECTANT WIPES	AP080320	4223	Maintenance - Building	408.37
STATE INDUSTRIAL PRODUCTS	DISINFECTANT	AP080320-2	4223	Maintenance - Building	193.21
STEVE PIPER & SONS, INC.	TUB GRINDER	AP080320	4243	Rent - Equipment	1,975.00
TITAN IMAGE GROUP INC	COOLING MASKS	AP080320	4219	Liability Insurance	194.31
TRAFFIC CONTROL AND PROTECTION	SIGNS	AP080320	4257	Supplies - Other	564.00
TRI-K INC	LUBRICANTS	AP080320	4225	Maintenance - Equipment	501.70
WILLOWBROOK FORD, INC.	ALIGNMENT FOR #112	AP080320	4229	Maintenance - Vehicles	169.95
				Total Public Works, Streets	36,978.93

CITY OF DARIEN
Expenditure Journal
General Fund
Police Department
From 7/21/2020 Through 8/3/2020

<u>Vendor Name</u>	<u>Invoice Description</u>	<u>Session ID</u>	<u>Acct Code</u>	<u>Acct Title</u>	<u>Dept Amount</u>
COLLEGE OF DU PAGE	TRAINING CLASSES- NICHOLAS SKWERES	AP080320	4263	Training and Education	298.00
DUPAGE COUNTY PUBLIC WORKS	SEWER BILL- POLICE DEPT	AP080320	4271	Utilities (Elec,Gas,Wtr,Sewer)	320.74
IL PHLEBOTOMY SERVICES	BLOOD WORK - DAPC 20-7638	AP080320	4217	Investigation and Equipment	425.00
KIESLER POLICE SUPPLY COMPANY	AMMO	AP080320	4217	Investigation and Equipment	368.00
ODELSON & STERK LTD	LEGAL FEES- JUNE 2020	AP080320	4219	Liability Insurance	2,145.00
PRI MANAGEMENT GROUP	ROSE GONZALEZ- TRAINING CLASS	AP080320	4263	Training and Education	250.00
QUADIENT FINANCE USA INC	INK & LABELS FOR POSTAGE MACHINE	AP080320	4253	Supplies - Office	75.00
RAY O'HERRON CO. INC.	RANGE /SHOTGUN ACCESSORIES	AP080320	4217	Investigation and Equipment	246.97
RAY O'HERRON CO. INC.	RENTKA RETIREMENT BADGE	AP080320	4269	Uniforms	110.53
RAY O'HERRON CO. INC.	KOSIENIAK - BULLET PROOF VEST	AP080320	4269	Uniforms	680.00
STORINO, RAMELLO & DURKIN	LEGAL FEES	AP080320	4219	Liability Insurance	<u>638.00</u>
				Total Police Department	<u>5,557.24</u>
				Total General Fund	<u>75,348.78</u>

CITY OF DARIEN
Expenditure Journal
Water Fund
Public Works, Water
From 7/21/2020 Through 8/3/2020

Vendor Name	Invoice Description	Session ID	Acct Code	Acct Title	Dept Amount
ALARM DETECTION SYSTEMS INC	ALARM DETECTION-PUBLIC WORKS	AP080320	4223	Maintenance - Building	203.43
CARLS SEPTIC SERVICE, INC.	SEPTIC HAULING	AP080320	4223	Maintenance - Building	125.00
CASE LOTS, INC.	SANITIZERS AND BUILDING SUPPLIES	AP080320	4219	Liability Insurance	102.95
CASE LOTS, INC.	SANITIZERS AND BUILDING SUPPLIES	AP080320	4223	Maintenance - Building	172.20
COM ED	COM ED 3118112014 2103 75TH ST PUMP DARIEN	AP080320	4271	Utilities (Elec,Gas,Wtr,Sewer)	385.50
CONSTELLATION NEW ENERGY, INC.	CUST # 7281657-9 0 LAKEVIEW & OAKLEY	AP080320	4271	Utilities (Elec,Gas,Wtr,Sewer)	24.51
CONSTELLATION NEW ENERGY, INC.	CUST # 7281657-11 67TH RIDGE	AP080320	4271	Utilities (Elec,Gas,Wtr,Sewer)	40.55
CONSTELLATION NEW ENERGY, INC.	CUST #7281657-7 18W736 MANNING	AP080320	4271	Utilities (Elec,Gas,Wtr,Sewer)	71.50
CONSTELLATION NEW ENERGY, INC.	CUST #7281657-8 1220 PLAINFIELD RD	AP080320	4271	Utilities (Elec,Gas,Wtr,Sewer)	2,109.10
CORRPRO COMPANIES, INC.	CATHODIC PROTECTION FIELD-WILLMETTE PUMP STATION	AP080320	4231	Maintenance - Water System	950.00
DIESEL SERVICE CENTER	REPAIRS ON #402	AP080320	4225	Maintenance - Equipment	2,507.77
DUPAGE COUNTY DIV OF TRANSPORT	ROAD PERMIT- CASS AVE / 67TH ST	AP080320-2	4231	Maintenance - Water System	100.00
ILLINI POWER PRODUCTS	GENERATOR FOR PLANT #2	AP080320	4223	Maintenance - Building	1,210.00
NICOR GAS	NICOR 05002110004 1930 MANNING RD DARIEN	AP080320	4271	Utilities (Elec,Gas,Wtr,Sewer)	48.32
POMP'S TIRE SERVICE, INC.	TIRES	AP080320	4225	Maintenance - Equipment	1,077.36
RED WING SHOES	SCHUSTER -BOOTS	AP080320	4219	Liability Insurance	284.74
RED WING SHOES	KOUDELIK- UNIFORM	AP080320	4269	Uniforms	54.00
RED WING SHOES	KOUDELIK- UNIFORM	AP080320	4269	Uniforms	70.98
RED WING SHOES	SCHUSTER- UNIFORM	AP080320	4269	Uniforms	144.00

CITY OF DARIEN
Expenditure Journal
Water Fund
Public Works, Water
From 7/21/2020 Through 8/3/2020

<u>Vendor Name</u>	<u>Invoice Description</u>	<u>Session ID</u>	<u>Acct Code</u>	<u>Acct Title</u>	<u>Dept Amount</u>
RED WING SHOES	SCHUSTER- UNIFORM	AP080320	4269	Uniforms	156.56
STATE CHEMICAL SOLUTIONS	DISINFECTANTS	AP080320	4223	Maintenance - Building	193.21
STATE CHEMICAL SOLUTIONS	DISINFECTANTS	APVOID080320	4223	Maintenance - Building	(193.21)
STATE INDUSTRIAL PRODUCTS	SEPTIC	AP080320	4223	Maintenance - Building	335.69
STATE INDUSTRIAL PRODUCTS	SEPTIC	AP080320	4223	Maintenance - Building	404.58
STATE INDUSTRIAL PRODUCTS	DISINFECTANT WIPES	AP080320	4223	Maintenance - Building	408.37
STATE INDUSTRIAL PRODUCTS	DISINFECTANT	AP080320-2	4223	Maintenance - Building	193.21
TITAN IMAGE GROUP INC	COOLING MASKS	AP080320	4219	Liability Insurance	194.30
TITAN IMAGE GROUP INC	BEUSSE- UNIFORM	AP080320	4269	Uniforms	344.00
TRAFFIC CONTROL AND PROTECTION	SIGNS	AP080320	4231	Maintenance - Water System	564.00
VULCAN CONSTRUCTION MATERIALS	STONE	AP080320	4231	Maintenance - Water System	1,723.70
				Total Public Works, Water	14,006.32
				Total Water Fund	14,006.32

CITY OF DARIEN
Expenditure Journal
Motor Fuel Tax
MFT Expenses
From 7/21/2020 Through 8/3/2020

<u>Vendor Name</u>	<u>Invoice Description</u>	<u>Session ID</u>	<u>Acct Code</u>	<u>Acct Title</u>	<u>Dept Amount</u>
CONSTELLATION NEW ENERGY, INC.	SW CORNER 75TH ST /PLAINFIELD RD	AP080320	4840	Street Lights	379.84
CONSTELLATION NEW ENERGY, INC.	9S720 LEMONT RD	AP080320	4840	Street Lights	97.51
CONSTELLATION NEW ENERGY, INC.	LITE RT/25 CONTRLR S FRONTA 0 E CASS ST	AP080320	4840	Street Lights	36.72
CONSTELLATION NEW ENERGY, INC.	0 CASS AVE LITE RT /25 N OF JAMES PETER CT	AP080320	4840	Street Lights	17.92
ORANGE CRUSH LLC	HOT ASPHALT MIX	AP080320	4245	Road Material	234.00
ORANGE CRUSH LLC	HOT ASPHALT MIX	AP080320	4245	Road Material	447.85
ORANGE CRUSH LLC	DUMP BROKEN ASPHALT	AP080320	4245	Road Material	300.00
				Total MFT Expenses	1,513.84
				Total Motor Fuel Tax	1,513.84

CITY OF DARIEN
Expenditure Journal
Water Depreciation Fund
Depreciation Expenses
From 7/21/2020 Through 8/3/2020

<u>Vendor Name</u>	<u>Invoice Description</u>	<u>Session ID</u>	<u>Acct Code</u>	<u>Acct Title</u>	<u>Dept Amount</u>
DUKES	FOX FURY LIGHT	AP080320	4390	Capital Improv-Infrastructure	2,179.00
				Total Depreciation Expenses	2,179.00
				Total Water Depreciation Fund	2,179.00
Report Total					93,047.94

AGENDA MEMO

City Council

August 3, 2020

ISSUE STATEMENT

A resolution authorizing the purchase of new office equipment from Midwest Office Interiors to replace current equipment in use by the police department using Department of Justice (DOJ) award money in the amount of \$16,995.71.

RESOLUTION

BACKGROUND/HISTORY

To better address the needs of the detectives, staff looked into replacing old furniture and replacing it with office furniture that was more functional and better able to keep everything organized, uniform and professional in appearance. We will replace desks with new units that provide more workspace and will accommodate the additional personnel in the detective's area. The new furniture will increase storage units for equipment and reference materials. All quotes also include the cost of delivery and set up.

The Darien Police Department is a proud participant in the United States Department of Justice Equitable Sharing Fund for State and Local Law Enforcement Agencies. For the last two years, the Darien Police Department has participated in federal task forces whose goal is to stem the flow of illegal narcotics into the Chicago metropolitan area, which is one of the major hubs for illegal narcotics coming into the United States. It is the goal of this program to not only cut off the flow of illegal narcotics into the area, but to take away and use the tools, proceeds and property derived from any criminal activity against the offenders. These seized tools, proceeds and property are ultimately a deterrent to criminal activity and an enhancement to law enforcement. Under the *Guidelines of the Equitable Sharing Program*, the funds received cannot be used to replace or supplant the police department's regularly budgeted monies but augment the police budget. These seized monies may only be used by the police department in order to augment the police budget. This purchase meets the *Guidelines of the Equitable Sharing Program* and will provide an important tool for the police department that otherwise would not be available without participation in the Equitable Sharing Program. The cash balance of this fund is \$383,076.40 as of June 30, 2020.

Proposals/Bids

New Office Furniture for Sergeants Office	
COMPANY	AMOUNT
Midwest Office Interiors	\$16,995.71
Rieke Office Interiors	\$20,020.00
Villa Park Office Equipment	\$24,110.94

STAFF/COMMITTEE RECOMMENDATION

Committee recommends approval of the resolution authorizing the purchase of the new office furniture from Midwest Office Interiors using federal equitable sharing funds in the amount of \$16,995.71.

ALTERNATE CONSIDERATION

As recommended.

DECISION MODE

This item will be placed on the August 3, 2020, City Council agenda for formal consideration.

10330 Argonne Woods Dr, Suite 600
 Woodridge, IL 60517
 Phone: (630) 850-8700
 Fax: (630) 783-2143

Proposal

PROPOSAL: 43014

DATE: 07/01/20

PROJECT#: 732-261

PROPOSAL FOR:	INSTALL AT:
Darien Police Department 1702 Plainfield Road Darien, IL 60561	Darien Police Department 1702 Plainfield Road Darien, IL 60561

SALESPERSON

Kevin Sietsema

CUSTOMER P/O

QUOTE VALID

06/08/20

#	QTY	PRODUCT	DESCRIPTION	SELL	EXTENDED
1	8	H36720R	Brigade Ped "R" Pull Freestanding B/B/F 20"D x 28"H	191.73	1,533.84
		.L	Lock: Lock		
		\$(P1)	P1 Paint Opts		
		.S	Charcoal		
			Tag(s): Detectives		
2	4	HSDCMP72 29	Stand-Alone Cnr 29-1/2Hx72W Mod Pnl	67.98	271.92
		\$(P1)	P1 Paint Opts		
		.S	Charcoal		
			Tag(s): Detectives		
3	4	HSDDL29	29.5"H Corner Desk Leg	54.45	217.80
		\$(P1)	P1 Paint Opts		
		.S	Charcoal		
			Tag(s): Detectives		
4	1	HSDEP242 9F	24'D End-Panel Supports: Freestanding	64.02	64.02
		\$(P1)	P1 Paint Opts		
		.S	Charcoal		
			Tag(s): Detectives		
5	1	HSDEP242 9F	24'D End-Panel Supports: Freestanding	64.02	64.02
			CONTINUED...		



10330 Argonne Woods Dr, Suite 600
 Woodridge, IL 60517
 Phone: (630) 850-8700
 Fax: (630) 783-2143

Proposal

PROPOSAL: 43014

DATE: 07/01/20

PROJECT#: 732-261

PROPOSAL FOR:	INSTALL AT:
Darien Police Department 1702 Plainfield Road Darien, IL 60561	Darien Police Department 1702 Plainfield Road Darien, IL 60561

SALESPERSON

Kevin Sietsema

CUSTOMER P/O

QUOTE VALID

06/08/20

#	QTY	PRODUCT	DESCRIPTION	SELL	EXTENDED
		\$ (P1) .S	P1 Paint Opts Charcoal		
			Tag(s): Detectives		
6	4	HSDMP429	Full-Hgt 29-1/2Hx42W Mod Pnl	61.71	246.84
		\$ (P1) .S	P1 Paint Opts Charcoal		
			Tag(s): Detectives		
7	4	HSDMP489	Full-Hgt 29-1/2Hx48W Mod Pnl	64.02	256.08
		\$ (P1) .S	P1 Paint Opts Charcoal		
			Tag(s): Detectives		
8	1	HSDMP609	Full-Hgt 29-1/2Hx60W Mod Pnl	65.67	65.67
		\$ (P1) .S	P1 Paint Opts Charcoal		
			Tag(s): Detectives		
9	4	HSDSL242 9F	24"D Support Leg: Freestanding	66.99	267.96
		\$ (P1) .S	P1 Paint Opts Charcoal		
			Tag(s): Detectives		



10330 Argonne Woods Dr, Suite 600
 Woodridge, IL 60517
 Phone: (630) 850-8700
 Fax: (630) 783-2143

Proposal

PROPOSAL: 43014

DATE: 07/01/20

PROJECT#: 732-261

PROPOSAL FOR:	INSTALL AT:
Darien Police Department 1702 Plainfield Road Darien, IL 60561	Darien Police Department 1702 Plainfield Road Darien, IL 60561

SALESPERSON
Kevin Sietsema

CUSTOMER P/O

QUOTE VALID
06/08/20

#	QTY	PRODUCT	DESCRIPTION	SELL	EXTENDED
10	4	HWR2442P	Systems Rectangular Worksurface Edgeband 24D x 42W	125.40	501.60
		\$(L1STD)	Grd L1 Standard Laminates		
		.LSA1	Sterling Ash		
		.SA	Sterling Ash		
		.S	Grommet: Charcoal		
			Tag(s): Detectives		
11	1	HWR2460P	Systems Rectangular Worksurface Edgeband 24D x 60W	157.41	157.41
		\$(L1STD)	Grd L1 Standard Laminates		
		.LSA1	Sterling Ash		
		.SA	Sterling Ash		
		.S	Grommet: Charcoal		
			Tag(s): Detectives		
12	2	HWV95ABL P	Systems 72x48x24x30Left Corner Cove Worksurface Edgebd	282.81	565.62
		\$(L1STD)	Grd L1 Standard Laminates		
		.LSA1	Sterling Ash		
		.SA	Sterling Ash		
		.S	Grommet: Charcoal		
			Tag(s): Detectives		
13	2	HWV95ABR P	Systems 72x48x24x30Rt Corner Cove Worksurface Edgeband	282.81	565.62
		\$(L1STD)	Grd L1 Standard Laminates		
			CONTINUED...		



10330 Argonne Woods Dr, Suite 600
 Woodridge, IL 60517
 Phone: (630) 850-8700
 Fax: (630) 783-2143

Proposal

PROPOSAL: 43014

DATE: 07/01/20

PROJECT#: 732-261

PROPOSAL FOR:	INSTALL AT:
Darien Police Department 1702 Plainfield Road Darien, IL 60561	Darien Police Department 1702 Plainfield Road Darien, IL 60561

SALESPERSON

Kevin Sietsema

CUSTOMER P/O

QUOTE VALID

06/08/20

#	QTY	PRODUCT	DESCRIPTION	SELL	EXTENDED
		.LSA1	Sterling Ash		
		.SA	Sterling Ash		
		.S	Grommet: Charcoal		
14	2	HSDEP242 9F	24'D End-Panel Supports: Freestanding	64.02	128.04
		\$(P1)	P1 Paint Opts		
		.S	Charcoal		
15	2	HSDEP242 9F	24'D End-Panel Supports: Freestanding	64.02	128.04
		\$(P1)	P1 Paint Opts		
		.S	Charcoal		
			Tag(s): Detectives		
16	2	HSDEP302 9F	30"D End-Panel Supports: Freestanding	71.28	142.56
		\$(P1)	P1 Paint Opts		
		.S	Charcoal		
			Tag(s): Detectives		
17	2	HSDEP302 9F	30"D End-Panel Supports: Freestanding	71.28	142.56
		\$(P1)	P1 Paint Opts		
		.S	Charcoal		
			CONTINUED...		



10330 Argonne Woods Dr, Suite 600
 Woodridge, IL 60517
 Phone: (630) 850-8700
 Fax: (630) 783-2143

Proposal

PROPOSAL: 43014

DATE: 07/01/20

PROJECT#: 732-261

PROPOSAL FOR:	INSTALL AT:
Darien Police Department 1702 Plainfield Road Darien, IL 60561	Darien Police Department 1702 Plainfield Road Darien, IL 60561

SALESPERSON

Kevin Sietsema

CUSTOMER P/O

QUOTE VALID

06/08/20

#	QTY	PRODUCT	DESCRIPTION	SELL	EXTENDED
			Tag(s): Detectives		
18	1	H36720R	Brigade Ped "R" Pull Freestanding B/B/F 20"D x 28"H	191.73	191.73
		.L	Lock: Lock		
		\$(P1)	P1 Paint Opts		
		.S	Charcoal		
			Tag(s): Detectives		
19	4	HFSC1836 40N	Flagship Stg Cab 39 1/8Hx36Wx18D N Pulls-2 Adj Shlf	445.62	1,782.48
		.L	Standard Random Key Lock		
		\$(P1)	P1 Paint Opts		
		.S	Charcoal		
			Tag(s): Detectives		
20	4	HVL705	Big & Tall High Back Mesh	329.28	1,317.12
		\$(1)	Grd 1 Uph		
		.VM	Fabric: Black		
		10	COLOR: Black		
			Tag(s): Detectives		
21	1	HTLCREDB	Preside 60 Buffet Credenza	1,091.20	1,091.20
		.G	EDGE: 2mm/Flat		
		SA	Sterling Ash		
			CONTINUED...		



10330 Argonne Woods Dr, Suite 600
 Woodridge, IL 60517
 Phone: (630) 850-8700
 Fax: (630) 783-2143

Proposal

PROPOSAL: 43014

DATE: 07/01/20

PROJECT#: 732-261

PROPOSAL FOR:	INSTALL AT:
Darien Police Department 1702 Plainfield Road Darien, IL 60561	Darien Police Department 1702 Plainfield Road Darien, IL 60561

SALESPERSON

Kevin Sietsema

CUSTOMER P/O

QUOTE VALID

06/08/20

#	QTY	PRODUCT	DESCRIPTION	SELL	EXTENDED
		\$(L1STD) .LSA1	Grd L1 Standard Laminates Sterling Ash		
		\$(L1STD) .LSA1 .3	Grd L1 Standard Laminates Sterling Ash Pull:Rounded SquareMatteChrome		
			Tag(s): Detectives		
22	2	H36720R	Brigade Ped "R" Pull Freestanding B/B/F 20"D x 28"H	191.73	383.46
		.L \$(P1) .S	Lock: Lock P1 Paint Opts Charcoal		
			Tag(s): Evidence		
23	4	HHN83112 4	Flat Bracket 24D	21.12	84.48
		.S	Color: Charcoal		
			Tag(s): Evidence		
24	2	HSDDL29	29.5"H Corner Desk Leg	54.45	108.90
		\$(P1) .S	P1 Paint Opts Charcoal		
			Tag(s): Evidence		
25	3	HSDEP112 9F	11"D End-Panel Supports: Freestanding	60.39	181.17
			CONTINUED...		



10330 Argonne Woods Dr, Suite 600
 Woodridge, IL 60517
 Phone: (630) 850-8700
 Fax: (630) 783-2143

Proposal

PROPOSAL: 43014

DATE: 07/01/20

PROJECT#: 732-261

PROPOSAL FOR:	INSTALL AT:
Darien Police Department 1702 Plainfield Road Darien, IL 60561	Darien Police Department 1702 Plainfield Road Darien, IL 60561

SALESPERSON
Kevin Sietsema

CUSTOMER P/O

QUOTE VALID
06/08/20

#	QTY	PRODUCT	DESCRIPTION	SELL	EXTENDED
		\$(P1) .S	P1 Paint Opts Charcoal Tag(s): Evidence		
26	2	HSDEP242 9F	24'D End-Panel Supports: Freestanding	64.02	128.04
		\$(P1) .S	P1 Paint Opts Charcoal Tag(s): Evidence		
27	6	HSDG	Gussets (1 Pr)	37.62	225.72
		\$(P1) .S	P1 Paint Opts Charcoal Tag(s): Evidence		
28	1	HWR2424P N	Systems Rectanular Wksfc Edgeband 24D X 24W No Grom	100.65	100.65
		\$(L1STD) .LSA1 .SA	Grd L1 Standard Laminates Sterling Ash Sterling Ash Tag(s): Evidence		
29	1	HWR2430P	Systems Rectangular Worksurface Edgeband 24D x 30W	105.60	105.60
		\$(L1STD)	Grd L1 Standard Laminates CONTINUED...		



10330 Argonne Woods Dr, Suite 600
 Woodridge, IL 60517
 Phone: (630) 850-8700
 Fax: (630) 783-2143

Proposal

PROPOSAL: 43014

DATE: 07/01/20

PROJECT#: 732-261

PROPOSAL FOR:	INSTALL AT:
Darien Police Department 1702 Plainfield Road Darien, IL 60561	Darien Police Department 1702 Plainfield Road Darien, IL 60561

SALESPERSON

Kevin Sietsema

CUSTOMER P/O

QUOTE VALID

06/08/20

#	QTY	PRODUCT	DESCRIPTION	SELL	EXTENDED
		.LSA1	Sterling Ash		
		.SA	Sterling Ash		
		.S	Grommet: Charcoal		
			Tag(s): Evidence		
30	1	HWR2442P	Systems Rectangular Worksurface Edgeband 24D x 42W	125.40	125.40
		\$(L1STD)	Grd L1 Standard Laminates		
		.LSA1	Sterling Ash		
		.SA	Sterling Ash		
		.S	Grommet: Charcoal		
			Tag(s): Evidence		
31	1	HVV93AAL P	Systems 72x36x24x24Left Corner Cove Worksurface Edgebd	220.44	220.44
		\$(L1STD)	Grd L1 Standard Laminates		
		.LSA1	Sterling Ash		
		.SA	Sterling Ash		
		.S	Grommet: Charcoal		
			Tag(s): Evidence		
32	1	HVV93AAR P	Systems 72x36x24x24Rt Corner Cove Worksurface Edgeband	220.44	220.44
		\$(L1STD)	Grd L1 Standard Laminates		
		.LSA1	Sterling Ash		
		.SA	Sterling Ash		
		.S	Grommet: Charcoal		
			CONTINUED...		



10330 Argonne Woods Dr, Suite 600
 Woodridge, IL 60517
 Phone: (630) 850-8700
 Fax: (630) 783-2143

Proposal

PROPOSAL: 43014

DATE: 07/01/20

PROJECT#: 732-261

PROPOSAL FOR:	INSTALL AT:
Darien Police Department 1702 Plainfield Road Darien, IL 60561	Darien Police Department 1702 Plainfield Road Darien, IL 60561

SALESPERSON
Kevin Sietsema

CUSTOMER P/O

QUOTE VALID
06/08/20

#	QTY	PRODUCT	DESCRIPTION	SELL	EXTENDED
			Tag(s): Evidence		
33	1	HFMSC182 830RWB	Modular Storage Cabinet 18"D x 28"H x 30"W	434.70	434.70
		.L	Standard Random Key Lock		
		.G	Glide		
		\$(P1)	P1 Paint Opts		
		.S	Charcoal		
			Tag(s): Evidence		
34	1	HFSC1836 40R	Flagship Stg Cab 39 1/8Hx36Wx18D R Pulls-2 Adj Shlf	445.62	445.62
		.L	Standard Random Key Lock		
		\$(P1)	P1 Paint Opts		
		.S	Charcoal		
			Tag(s): Evidence		
35	2	HVL705	Big & Tall High Back Mesh	329.28	658.56
		\$(1)	Grd 1 Uph		
		.VM	Fabric: Black		
		10	COLOR: Black		
			Tag(s): Evidence		
36	6	HPWRMOD2 UWM	2 Receptacle 2 USB Under-Wrksf Mount	168.41	1,010.46
		...	Skipped Option		
			CONTINUED...		



10330 Argonne Woods Dr, Suite 600
 Woodridge, IL 60517
 Phone: (630) 850-8700
 Fax: (630) 783-2143

Proposal

PROPOSAL: 43014

DATE: 07/01/20

PROJECT#: 732-261

PROPOSAL FOR:	INSTALL AT:
Darien Police Department 1702 Plainfield Road Darien, IL 60561	Darien Police Department 1702 Plainfield Road Darien, IL 60561

SALESPERSON

Kevin Sietsema

CUSTOMER P/O

QUOTE VALID

06/08/20

#	QTY	PRODUCT	DESCRIPTION	SELL	EXTENDED
37	1	HF22	Master Key (One Key)	10.90	10.90
38	3	HF23S	Contain Satin Removable Lock Core Kit	17.44	52.32
		.X101E	KEY NUMBER: 101E		
39	3	HF23S	Contain Satin Removable Lock Core Kit	17.44	52.32
		.X102E	KEY NUMBER: 102E		
40	3	HF23S	Contain Satin Removable Lock Core Kit	17.44	52.32
		.X103E	KEY NUMBER: 103E		
41	3	HF23S	Contain Satin Removable Lock Core Kit	17.44	52.32
		.X104E	KEY NUMBER: 104E		



10330 Argonne Woods Dr, Suite 600
 Woodridge, IL 60517
 Phone: (630) 850-8700
 Fax: (630) 783-2143

Proposal

PROPOSAL: 43014

DATE: 07/01/20

PROJECT#: 732-261

PROPOSAL FOR:	INSTALL AT:
Darien Police Department 1702 Plainfield Road Darien, IL 60561	Darien Police Department 1702 Plainfield Road Darien, IL 60561

SALESPERSON
Kevin Sietsema

CUSTOMER P/O

QUOTE VALID
06/08/20

#	QTY	PRODUCT	DESCRIPTION	SELL	EXTENDED
42	2	HF23S	Contain Satin Removable Lock Core Kit	17.44	34.88
		.X105E	KEY NUMBER: 105E		
43	2	HF23S	Contain Satin Removable Lock Core Kit	17.44	34.88
		.X106E	KEY NUMBER: 106E		
44	4	4168BL	Safco Coat Racks	80.00	320.00
45	1	Labor	Receive, Deliver & Install - Normal Business Hours	2,250.00	2,250.00



Installation available from Midwest Office Interiors
 Thank you for the opportunity!

SUBTOTAL.....: 14,745.71

DEPOSIT REQUIRED: 8,498.00

INSTALL.....: 2,250.00

ACCEPTED BY _____

DATE ACCEPTED _____

TOTAL -----
16,995.71
=====

ROI

RIEKE OFFICE INTERIORS

2000 FOX LANE - ELGIN - ILLINOIS - 60123
847-622-9711 www.rieke.com



QUOTATION

TO:

CITY OF DARIEN
POLICE DEPARTMENT
1710 PLAINFIELD ROAD
DARIEN, IL 60561

SHIP TO:

CITY OF DARIEN
POLICE DEPARTMENT
1710 PLAINFIELD ROAD
DARIEN, IL 60561

ATTN:

ATTN:

Quote No.	Date	Cust No	S/M	Your Referenced Inquiry	Delivery Promise	F.O.B.	Expiration
0062618	6/2/2020	DAR000	CC1			OUR DOCK	
Item	Quantity	UM	Part	Description		Price \$	Extension \$
001	4.00	EA	MPRIVATE	DETECTIVE OFFICE DESKS *INCLUDES METAL FILE STORAGE*		1,220.00	4,880.00
002	4.00	EA	NMISC	DETECTIVE OFFICE BOOKCASES *METAL*		395.00	1,580.00
004	1.00	BX	MCABINETRY	DETECTIVE OFFICE COFFEE BAR		1,285.00	1,285.00
005	1.00	EA	MWORKSTATION	DETECTIVE OFFICE PRINTER/ WORKSTATION *INCLUDES METAL FILE STORAGE*		455.00	455.00
006	4.00	EA	NMISC	DETECTIVE OFFICE - HALL TREE 1 PER DESK BLACK POWDER COAT		290.00	1,160.00
007	1.00	EA	MPRIVATE	EVIDENCE OFFICE DESK *INCLUDES METAL STORAGE*		2,455.00	2,455.00
009	1.00	BX	MCABINETRY	EVIDENCE OFFICE STORAGE CABINET		505.00	505.00
010	6.00	EA	ROI300	ROI TASK CHAIR ROI 300 (4) FOR DETECTIVE OFFICE, (1) FOR EVIDENCE OFFICE		325.00	1,950.00
011	1.00	EA	NKEY	ROI MASTER KEY THIS IS FOR ROI PRODUCT. *FILE STORAGE NOT INCLUDED*		25.00	25.00
012	5.00	EA	NMISC	POWER & DATA UNIT 1 PER DESK		195.00	975.00
014	1.00	EA	DELIVERY	DELIVERY TO DARIEN, IL NON-UNION LABOR		170.00	170.00

ROI MAKES EVERY EFFORT TO MAINTAIN CORRECT PRICING. HOWEVER, DUE TO THE EVER-CHANGING TARIFFS, PRICING ON NEW PRODUCT MAY CHANGE BETWEEN THE INITIAL QUOTE AND ORDER PLACEMENT.

LEASING OPTIONS AVAILABLE, ASK FOR ACCOUNT REP FOR MORE INFORMATION

QUOTATION

TO:

CITY OF DARIEN
POLICE DEPARTMENT
1710 PLAINFIELD ROAD
DARIEN, IL 60561

SHIP TO:

CITY OF DARIEN
POLICE DEPARTMENT
1710 PLAINFIELD ROAD
DARIEN, IL 60561

ATTN:

ATTN:

Quote No.	Date	Cust No	S/M	Your Referenced Inquiry	Delivery Promise	F.O.B.	Expiration
0062618	6/2/2020	DAR000	CC1			OUR DOCK	
Item	Quantity	UM	Part	Description		Price \$	Extension \$
015	1.00	EA	OUTSIDE INSTALLATION	DURING NORMAL BUSINESS HOURS MONDAY - FRIDAY 7:00 AM - 4:00 PM WITH USE OF ELEVATOR, DOCK AND ELECTRICITY OUTSIDE INSTALLATION UNION INSTALLATION DURING NORMAL BUSINESS HOURS MONDAY - FRIDAY 7:00AM - 4:00PM WITH USE OF ELEVATOR, DOCK AND ELECTRICITY DOES NOT INCLUDE CHARGE FOR DUMPSTER, IF ONE IS REQUIRED		4,580.00	4,580.00
Total for Quote \$							20,020.00

ROI MAKES EVERY EFFORT TO MAINTAIN CORRECT PRICING. HOWEVER, DUE TO THE EVER-CHANGING TARIFFS, PRICING ON NEW PRODUCT MAY CHANGE BETWEEN THE INITIAL QUOTE AND ORDER PLACEMENT.

LEASING OPTIONS AVAILABLE, ASK FOR ACCOUNT REP FOR MORE INFORMATION



RIEKE OFFICE INTERIORS

Terms & Conditions Agreement

COMPANY: CITY OF DARIEN POLICE DEPARTMENT

QUOTE:62618

DATE: 06/02/2020

TOTAL AMOUNT OF QUOTE: \$20,020.00

The following conditions must be satisfied prior to order processing or scheduling the project installation:

- **A 50% down payment is required at the time of signing.**
NOTE: ALL ORDERS UNDER \$5,000.00 MUST BE PAID IN FULL PRIOR TO ORDER PROCESSING.
- The official installation date cannot be confirmed until all project revisions are finalized and signed off on.
- Signed/Dated **Quote** and **Terms & Conditions** documents.
- Any approved custom drawings **including signatures on each page.**
- Final color and finish selections.
- Final measurements are from drywall. The official installation date is established once final field measurements are completed. Installation is a **minimum 4 weeks** from date of final field measurement.
- Rieke Office Interiors is not responsible for irregularities, or abnormalities, in structural attributes that prevent symmetrical installation of our products. Changes, repairs or adjustments may result in new charges and are the sole responsibility of the client.

FULL PAYMENT OF OUTSTANDING BALANCE DUE ON DAY OF PROJECT INSTALLATION.

Payment arrangements to be made with your Account Manager, or ROI Accounts Receivable, in advance of installation completion.

*30 day past due balances are subject to a 1.5% monthly finance charge.

Any items that require correction will be promptly addressed under the terms of:

Rieke Office Interiors Product Warranty

(All ROI-manufactured product installed by our installers carries a lifetime warranty, exclusive of normal wear and tear).

Further Terms and Conditions

1. All client changes to agreed delivery and installation dates which occur 48 hours after the project appointment confirmation will result in **extra** delivery & installation charges. **Final payment remains due on the original project installation date.**
2. **All scheduling changes must be made a minimum of 48 hours in advance of scheduled delivery time.** An email reminder is sent approximately one week prior to the project installation appointment. **If client is not READY (for any reason), product delivery and installation charges will be substantially increased to reimburse all ROI labor and delivery costs incurred.**
3. All costs (labor & material) incurred due to cancellation of client order(s) are billable and solely the client's responsibility.
4. Unless otherwise stated, price is based on (1) one complete one-time installation -- phasing will involve additional charges.
5. Pricing is based on non-union installation performed during non-overtime hours (Monday-Friday 7:00 a.m.- 4:00 p.m.), with free use of lifts and elevators. **If an elevator is not available at the time of the scheduled installation, delivery may be postponed and additional delivery and installation charges WILL be charged to the client (see #1).**
6. All custom-order product manufactured/purchased according to client's project specifications is NON-RETURNABLE.
7. All electrical to be handled by a Certified Electrician. All connections must be complete and work area free from any trade activity.
8. Unloading and installation areas must be clean and clear.
9. All work requested of ROI installers (other than stated in client quote) will be quoted and charged separately.
10. A *Certificate of Insurance is available upon request* for coverage of product delivery and installation. When riders or additional coverages are required, all charges are a client responsibility.
11. All permits required are a client responsibility.
12. A Sale changed to a Lease **after** the order is placed will result in a \$100.00 processing fee.

*Photo Release

I hereby irrevocably authorize Rieke Office Interiors to copyright, publish, reproduce, exhibit, transmit, broadcast, televise, digitize, display, otherwise use, and permit others to use all images of purchased office furnishings, logos, and design components, in any manner, form, or format, whatsoever now or hereinafter created, including on the internet, and for any purpose, including, but not limited to, advertising or promotion of Rieke Office Interior products and services, without further consent from or payment to me.

APPROVE: _____ DISAPPROVE: _____

Accepted by Client: _____ Date: _____

(Signature indicates you are an authorized Company representative)

Please Print Name: _____

This signed "Terms & Conditions" indicates acceptance of the above-referenced quote and ALL terms & conditions as written.





DESIGN **PRESENTATION**

DARIEN POLICE DEPARTMENT

6/2/2020



DETECTIVE OFFICE PLAN

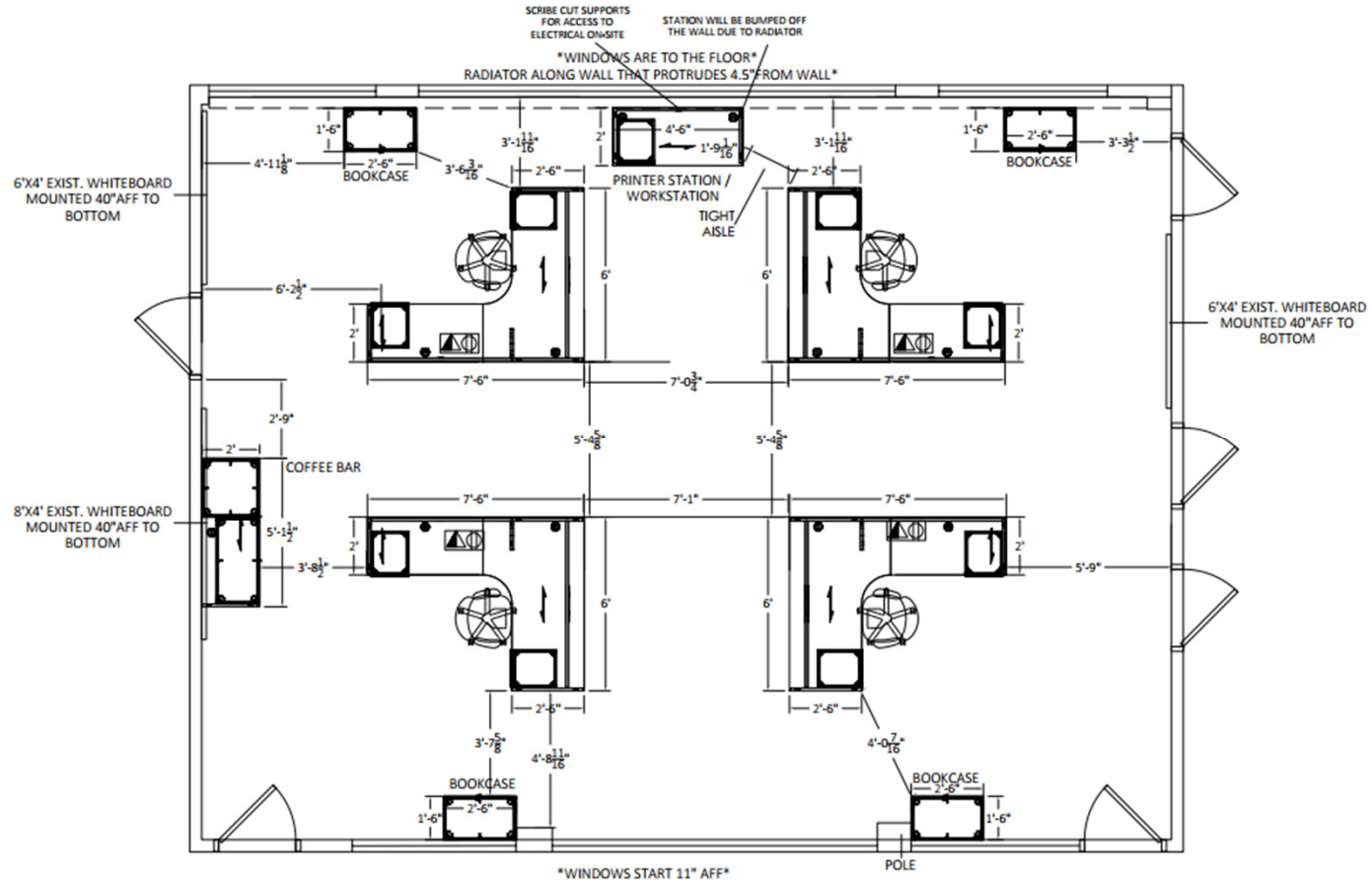

DETECTIVE OFFICE 3D'S

4 DESK UNITS & 4 BOOKCASE UNITS
KEYED ALIKE

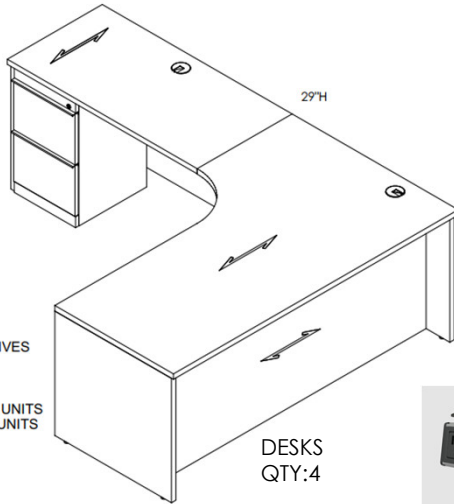

EACH DESK RECEIVES
1 - BOX/BOX/FILE
1 - FILE/FILE

2 - RIGHT HANDED UNITS
2 - LEFT-HANDED UNITS

DESKS
QTY:4



ROI300 SERIES CHAIR:
SEAT: GRAPHITE FABRIC
BACK: LIGHT GRAY MESH
FRAME: LIGHT GRAY
BASE: POLISHED ALUMINUM
ARMS: 3-WAY ADJUST.
CASTERS

CLIENT SIGNATURE: _____

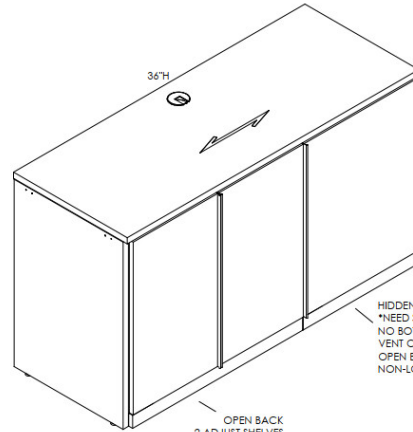

COFFEE BAR
QTY:1



1 POWER UNIT
PER DESK
1 - POWER
1 - USB



4X8 VENT
FINISH: BLACK, SILVER
OR WHITE

HIDDEN / MINI FRIDGE
NEED SPEC
NO BOTTOM AND FALSE FRONT WITH
VENT ON SIDE OF CABINET AND
OPEN BACK
NON-LOCKING

OPEN BACK
2 ADJUST SHELVES
NON-LOCKING



RECESSED HANDLE

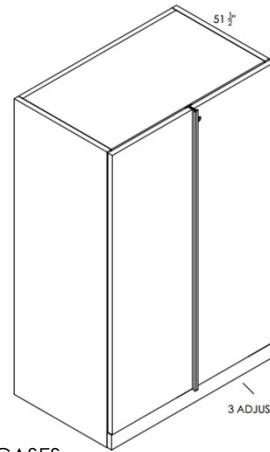

BOOKCASES
QTY:4

3 ADJUST. SHELVES /
LOCKING

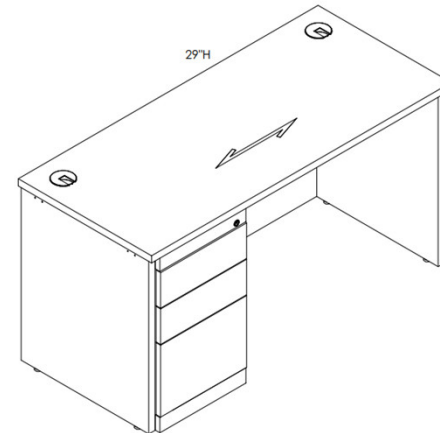

PRINTER / WORKSTATION
QTY:1



HALL TREE
1 PER DESK
QTY:4
FINISH: BLACK

ROI CATAPULT SERIES

SURFACES: GRAPHITE
EDGE: VINYL TO MATCH
SUPPORTS: GRAPHITE
MODESTY: GRAPHITE
COFFEE BAR CABINETS: _____
HANDLES: RECESSED *SEE BELOW*
METAL STORAGE
FILE STORAGE *METAL*
CLOSED BOOKCASE *METAL*
PAINT: KN MEDIUM GRAY
HANDLES: FULL PULL / SELF HANDED (S)
LOCK: UM BLACK

EVIDENCE OFFICE PLAN

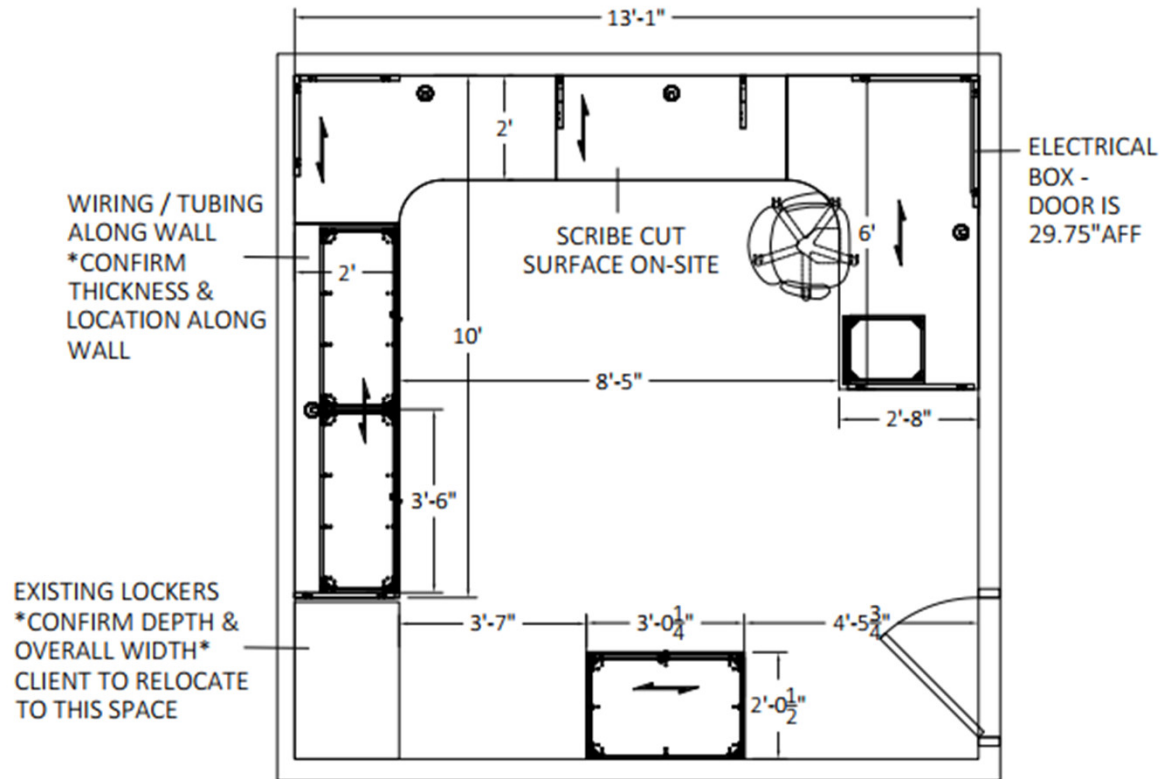

EVIDENCE OFFICE 3D

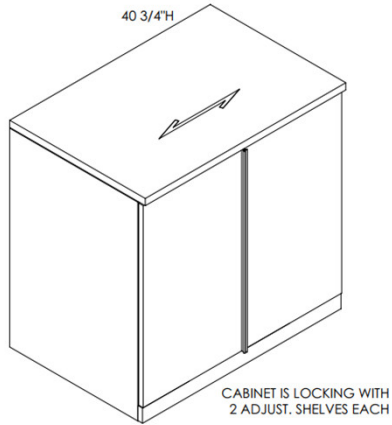

STORAGE CABINET

CABINET IS LOCKING WITH
2 ADJUST. SHELVES EACH

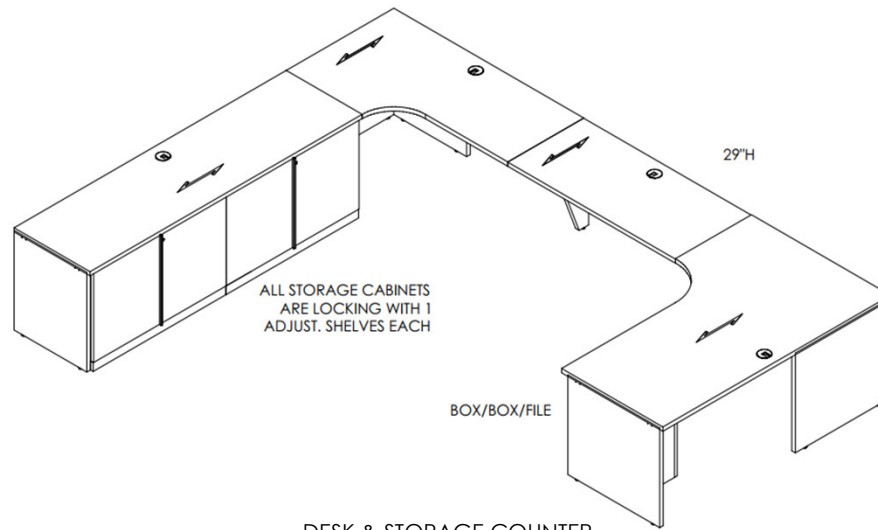

DESK & STORAGE COUNTER

ALL STORAGE CABINETS
ARE LOCKING WITH 1
ADJUST. SHELVES EACH

BOX/BOX/FILE



1 POWER UNIT
1 – POWER
1 – USB

ROI CATAPULT SERIES
SURFACES: GRPAHITE
EDGE: VINYL TO MATCH
SUPPORTS: GRAPHITE

METAL
BOX/BOX/FILE *METAL*
STORAGE CABINETS *METAL*
PAINT: KN MEDIUM GREY
HANDLES: SELF HANDED / FULL PULL (S)
LOCK: UM BLACK

ROI300 SERIES CHAIR:
SEAT: GRAPHITE FABRIC
BACK: LIGHT GRAY MESH
FRAME: LIGHT GRAY
BASE: POLISHED ALUMINUM
ARMS: 3-WAY ADJUST.
CASTERS



CLIENT SIGNATURE:

6/2/2020

CLIENT WANTS TO MATCH FINISHES OF THIS OFFICE

ROI CATAPULT SERIES

SURFACES: GRPAHITE
EDGE: VINYL TO MATCH
SUPPORTS: GRAPHITE

METAL

BOX/BOX/FILE *METAL*
STORAGE CABINETS *METAL*
PAINT: KN MEDIUM GREY
HANDLES: SELF HANDED / FULL PULL (S)
LOCK: UM BLACK



CLIENT SIGNATURE:

6/2/2020



RIEKE OFFICE INTERIORS

PARTNERS IN CREATING **INSPIRING SPACES**





Vil I a Park Office Equipment

1120 N. Vil I a Ave.
Vil I a Park, IL 60181-1054

(630) 279-2312 Fax: (630) 834-3634

Quote

Customer No.: 2537
Quote No.: 48017
Phone: (630) 353-8359
Fax:
Email: charkey@darienil.gov

www.vpoe.com

Quote To: **Darien Police Department**
1710 Plainfield Road
Darien, IL 60561

Ship To: **Darien Police Department**
1710 Plainfield Road
Darien, IL 60561

Contact: Carol Harkey

Date	Ship Via	F.O.B.	Terms		
04/22/20	MID	Origin	Net 30		
Purchase Order Number		Sales Person		Required	
		ST		04/22/20	
Quantity		Item Number	Description	Unit Price	Amount
Required	Warehouse				

REVISED 6/11/20

INVINCIBLE FURNITURE OPTION

**THE FOLLOWING QUOTE IS FOR
BUDGET PURPOSES UNTIL FINAL
LAYOUT AND FINISH SELECTIONS
HAVE BEEN MADE***

OPEN OFFICE AREA

LAMINATE TOP: STANDARD OPT.
METAL CHASSIS PAINT:STD. OPT

4	NEW	Invincible Furniture 6x7 L-Shape Desk w/Full Pedestal Pedestal *KEYED ALIKE*	1495.00	5980.00
4	SC3639HLK	Invincible Storage 2 Door Storage Cabinet 36"W x 39"H w/ Locking Turn Handle Compel Under Mount Power	586.00	2344.00

Authorized Signature _____

Date _____

E-Mail Address _____

Customer responsible for attainment and costs of all required permits

We Appreciate Your Business

Terms and Conditions of Quote: All signed off quotes & special orders are final, and NON -RETURNABLE.
New & Stock Items are NON-RETURNABLE. Pre-Owned items may be returned and are subject to a 30% re-stocking fee.

All orders are subject to a storage fee if not delivered within 30 days of purchase.

A 4% service charge will be applied to credit card payments over \$5000.00.

Deliveries cancelled or changed less than 48 Hours in advance may be subject to Change Order charges.

Ask your Sales Representative about our Carpet and Flooring Division



Vil I a Park Office Equipment

1120 N. Vil I a Ave.
Vil I a Park, IL 60181-1054

(630) 279-2312 Fax: (630) 834-3634

Quote

Customer No.: 2537
Quote No.: 48017
Phone: (630) 353-8359
Fax:
Email: charkey@darienil.gov

www.vpoe.com

Quote To: **Darien Police Department**
1710 Plainfield Road
Darien, IL 60561

Ship To: **Darien Police Department**
1710 Plainfield Road
Darien, IL 60561

Contact: Carol Harkey

Date	Ship Via	F.O.B.	Terms		
04/22/20	MID	Origin	Net 30		
Purchase Order Number		Sales Person			
		ST			
		Required			
		04/22/20			
Quantity		Item Number	Description	Unit Price	Amount
Required	Warehouse				
5		PWR-UNDR-BL	Module w/ 2 Standar outlets & 2 USB Ports	90.00	450.00
6		HVL705VM10	Hon Wave Mesh Big & Tall w/Integrated Lumbar Support Height/Width Adjustable Arms	375.99	2255.94
4		SAF4241BL	Safco Hook Head Coat Rack w/ 8 Arms Black	85.00	340.00
1.000		FREIGHT	Mfg. Freight	40.00	40.00
1		CUC6024FFB-P	Invincible Cube Series 24x60 Kneespace Credenza w/ FF & BBF Pedestals	679.00	679.00
1		CUSTOM	TOP LAMINATE: CHASSIS LAMINATE: HANDLE: SILVER BAR PULL Laminate Coffee Bar 109.5" x 25" x 36" with (1) Trash Grommet & 18" Pull out Waste Receptacle (1) 20"W Space for Fridge	5995.00	5995.00

Authorized Signature _____
Date _____
E-Mail Address _____

Customer responsible for attainment and costs of all required permits
We Appreciate Your Business

Terms and Conditions of Quote: All signed off quotes & special orders are final, and NON -RETURNABLE.
New & Stock Items are NON-RETURNABLE. Pre-Owned items may be returned and are subject to a 30% re-stocking fee.

All orders are subject to a storage fee if not delivered within 30 days of purchase.
A 4% service charge will be applied to credit card payments over \$5000.00.

Deliveries cancelled or changed less than 48 Hours in advance may be subject to Change Order charges.

Ask your Sales Representative about our Carpet and Flooring Division



Vil I a Park Office Equipment

1120 N. Vil I a Ave.
Vil I a Park, IL 60181-1054

(630) 279-2312 Fax: (630) 834-3634

Quote

Customer No.: 2537
Quote No.: 48017
Phone: (630) 353-8359
Fax:
Email: charkey@darienil.gov

www.vpoe.com

Quote To: Darien Police Department
1710 Plainfield Road
Darien, IL 60561

Ship To: Darien Police Department
1710 Plainfield Road
Darien, IL 60561

Contact: Carol Harkey

Date	Ship Via	F.O.B.	Terms		
04/22/20	MID	Origin	Net 30		
Purchase Order Number		Sales Person		Required	
		ST		04/22/20	
Quantity		Item Number	Description	Unit Price	Amount
Required	Warehouse				

(2) 35"W Double Door Cabinet
w/ Box Drawers Above

EVIDENCE ROOM-Seated Height

1		NEW	Invincible Cube Series 5.5x6.5 L-Shape Full Ped	1345.00	1345.00
2		SC3627LK	Invincible Storage 27"Hx36"W 2 Door Storage Cabinet w/Flush Handle 18.5"D	510.00	1020.00
1		RWSS2472HP	Haworth Unigroup Rectangular Worksurface - 24"D x 72"W High Pressure Laminate EXACT SIZE	216.00	216.00
1		RWSS2460HP	Haworth Unigroup Rectangular Worksurface - 24"D x 60"W High Pressure Laminate To be Cut Down to 24x56	198.00	198.00
1		RLL18SUPLP	Haworth Unigroup L-Support	89.00	89.00

Authorized Signature _____

Date _____

E-Mail Address _____

Customer responsible for attainment and costs of all required permits

We Appreciate Your Business

Terms and Conditions of Quote: All signed off quotes & special orders are final, and NON -RETURNABLE.
New & Stock Items are NON-RETURNABLE. Pre-Owned items may be returned and are subject to a 30% re-stocking fee.

All orders are subject to a storage fee if not delivered within 30 days of purchase.

A 4% service charge will be applied to credit card payments over \$5000.00.

Deliveries cancelled or changed less than 48 Hours in advance may be subject to Change Order charges.

Ask your Sales Representative about our Carpet and Flooring Division



Vil I a Park Office Equipment

1120 N. Vil I a Ave.
Vil I a Park, IL 60181-1054

(630) 279-2312 Fax: (630) 834-3634

Quote

Customer No.: 2537
Quote No.: 48017
Phone: (630) 353-8359
Fax:
Email: charkey@darienil.gov

www.vpoe.com

Quote To: **Darien Police Department**
1710 Plainfield Road
Darien, IL 60561

Ship To: **Darien Police Department**
1710 Plainfield Road
Darien, IL 60561

Contact: Carol Harkey

Date	Ship Via	F.O.B.	Terms		
04/22/20	MID	Origin	Net 30		
Purchase Order Number		Sales Person		Required	
		ST		04/22/20	
Quantity		Item Number	Description	Unit Price	Amount
Required	Warehouse				

1		SC3665HLK	Panel - 18"D x 27"H Thermal Fused Laminate Invincible Storage 65"Hx36"w 2 Door Storage Cabinet w/Locking Turn Handle	669.00	669.00
1.000		UNION	UNION DELIVERY AND INSTALLATION	2490.00	2490.00
				Quote subtotal	24110.94
				Quote total	24110.94

Authorized Signature _____
Date _____
E-Mail Address _____

Customer responsible for attainment and costs of all required permits
We Appreciate Your Business

Terms and Conditions of Quote: All signed off quotes & special orders are final, and NON -RETURNABLE.
New & Stock Items are NON-RETURNABLE. Pre-Owned items may be returned and are subject to a 30% re-stocking fee.

All orders are subject to a storage fee if not delivered within 30 days of purchase.
A 4% service charge will be applied to credit card payments over \$5000.00.

Deliveries cancelled or changed less than 48 Hours in advance may be subject to Change Order charges.

Ask your Sales Representative about our Carpet and Flooring Division



RESOLUTION NO. _____

A RESOLUTION AUTHORIZING THE PURCHASE OF OFFICE EQUIPMENT FROM MIDWEST OFFICE INTERIORS TO REPLACE CURRENT EQUIPMENT IN USE BY THE POLICE DEPARTMENT USING DEPARTMENT OF JUSTICE (DOJ) AWARD MONEY IN THE AMOUNT OF \$16,995.71

BE IT RESOLVED BY THE CITY COUNCIL OF THE CITY OF DARIEN, DU PAGE COUNTY, ILLINOIS, as follows:

SECTION 1: The City Council of the City of Darien hereby authorizes the City Administrator to purchase office equipment from Midwest Office Interiors using DOJ award money in the amount of \$16,995.71, attached hereto as "[Exhibit A](#)".

SECTION 2: This Resolution shall be in full force and effect from and after its passage and approval as provided by law.

PASSED BY THE CITY COUNCIL OF THE CITY OF DARIEN, DU PAGE COUNTY, ILLINOIS, this 3rd day of August, 2020.

AYES: _____
NAYS: _____
ABSENT: _____

APPROVED BY THE MAYOR OF THE CITY OF DARIEN, DU PAGE COUNTY, ILLINOIS, this 3rd day of August, 2020.

JOSEPH A. MARCHESE, MAYOR

ATTEST:

JOANNE E. RAGONA, CITY CLERK

APPROVED AS TO FORM:

CITY ATTORNEY

Midwest Office Interiors

10330 Argonne Woods Dr, Suite 600
 Woodridge, IL 60517
 Phone: (630) 850-8700
 Fax: (630) 783-2143

Proposal

PROPOSAL: 43014

DATE: 07/01/20

PROJECT#: 732-261

PROPOSAL FOR:	INSTALL AT:
Darien Police Department 1702 Plainfield Road Darien, IL 60561	Darien Police Department 1702 Plainfield Road Darien, IL 60561

SALESPERSON

Kevin Sietsema

CUSTOMER P/O

QUOTE VALID

06/08/20

#	QTY	PRODUCT	DESCRIPTION	SELL	EXTENDED
1	8	H36720R	Brigade Ped "R" Pull Freestanding B/B/F 20"D x 28"H	191.73	1,533.84
		.L	Lock: Lock		
		\$(P1)	P1 Paint Opts		
		.S	Charcoal		
			Tag(s): Detectives		
2	4	HSDCMP72 29	Stand-Alone Cnr 29-1/2Hx72W Mod Pnl	67.98	271.92
		\$(P1)	P1 Paint Opts		
		.S	Charcoal		
			Tag(s): Detectives		
3	4	HSDDL29	29.5"H Corner Desk Leg	54.45	217.80
		\$(P1)	P1 Paint Opts		
		.S	Charcoal		
			Tag(s): Detectives		
4	1	HSDEP242 9F	24'D End-Panel Supports: Freestanding	64.02	64.02
		\$(P1)	P1 Paint Opts		
		.S	Charcoal		
			Tag(s): Detectives		
5	1	HSDEP242 9F	24'D End-Panel Supports: Freestanding	64.02	64.02
			CONTINUED...		



10330 Argonne Woods Dr, Suite 600
 Woodridge, IL 60517
 Phone: (630) 850-8700
 Fax: (630) 783-2143

Proposal

PROPOSAL: 43014

DATE: 07/01/20

PROJECT#: 732-261

PROPOSAL FOR:	INSTALL AT:
Darien Police Department 1702 Plainfield Road Darien, IL 60561	Darien Police Department 1702 Plainfield Road Darien, IL 60561

SALESPERSON

Kevin Sietsema

CUSTOMER P/O

QUOTE VALID

06/08/20

#	QTY	PRODUCT	DESCRIPTION	SELL	EXTENDED
		\$ (P1) .S	P1 Paint Opts Charcoal		
			Tag(s): Detectives		
6	4	HSDMP429	Full-Hgt 29-1/2Hx42W Mod Pnl	61.71	246.84
		\$ (P1) .S	P1 Paint Opts Charcoal		
			Tag(s): Detectives		
7	4	HSDMP489	Full-Hgt 29-1/2Hx48W Mod Pnl	64.02	256.08
		\$ (P1) .S	P1 Paint Opts Charcoal		
			Tag(s): Detectives		
8	1	HSDMP609	Full-Hgt 29-1/2Hx60W Mod Pnl	65.67	65.67
		\$ (P1) .S	P1 Paint Opts Charcoal		
			Tag(s): Detectives		
9	4	HSDSL242 9F	24"D Support Leg: Freestanding	66.99	267.96
		\$ (P1) .S	P1 Paint Opts Charcoal		
			Tag(s): Detectives		



10330 Argonne Woods Dr, Suite 600
 Woodridge, IL 60517
 Phone: (630) 850-8700
 Fax: (630) 783-2143

Proposal

PROPOSAL: 43014

DATE: 07/01/20

PROJECT#: 732-261

PROPOSAL FOR:	INSTALL AT:
Darien Police Department 1702 Plainfield Road Darien, IL 60561	Darien Police Department 1702 Plainfield Road Darien, IL 60561

SALESPERSON
Kevin Sietsema

CUSTOMER P/O

QUOTE VALID
06/08/20

#	QTY	PRODUCT	DESCRIPTION	SELL	EXTENDED
10	4	HWR2442P	Systems Rectangular Worksurface Edgeband 24D x 42W	125.40	501.60
		\$(L1STD)	Grd L1 Standard Laminates		
		.LSA1	Sterling Ash		
		.SA	Sterling Ash		
		.S	Grommet: Charcoal		
			Tag(s): Detectives		
11	1	HWR2460P	Systems Rectangular Worksurface Edgeband 24D x 60W	157.41	157.41
		\$(L1STD)	Grd L1 Standard Laminates		
		.LSA1	Sterling Ash		
		.SA	Sterling Ash		
		.S	Grommet: Charcoal		
			Tag(s): Detectives		
12	2	HWV95ABL P	Systems 72x48x24x30Left Corner Cove Worksurface Edgebd	282.81	565.62
		\$(L1STD)	Grd L1 Standard Laminates		
		.LSA1	Sterling Ash		
		.SA	Sterling Ash		
		.S	Grommet: Charcoal		
			Tag(s): Detectives		
13	2	HWV95ABR P	Systems 72x48x24x30Rt Corner Cove Worksurface Edgeband	282.81	565.62
		\$(L1STD)	Grd L1 Standard Laminates		
			CONTINUED...		



10330 Argonne Woods Dr, Suite 600
 Woodridge, IL 60517
 Phone: (630) 850-8700
 Fax: (630) 783-2143

Proposal

PROPOSAL: 43014

DATE: 07/01/20

PROJECT#: 732-261

PROPOSAL FOR:	INSTALL AT:
Darien Police Department 1702 Plainfield Road Darien, IL 60561	Darien Police Department 1702 Plainfield Road Darien, IL 60561

SALESPERSON

Kevin Sietsema

CUSTOMER P/O

QUOTE VALID

06/08/20

#	QTY	PRODUCT	DESCRIPTION	SELL	EXTENDED
		.LSA1	Sterling Ash		
		.SA	Sterling Ash		
		.S	Grommet: Charcoal		
14	2	HSDEP242 9F	24'D End-Panel Supports: Freestanding	64.02	128.04
		\$(P1)	P1 Paint Opts		
		.S	Charcoal		
15	2	HSDEP242 9F	24'D End-Panel Supports: Freestanding	64.02	128.04
		\$(P1)	P1 Paint Opts		
		.S	Charcoal		
			Tag(s): Detectives		
16	2	HSDEP302 9F	30"D End-Panel Supports: Freestanding	71.28	142.56
		\$(P1)	P1 Paint Opts		
		.S	Charcoal		
			Tag(s): Detectives		
17	2	HSDEP302 9F	30"D End-Panel Supports: Freestanding	71.28	142.56
		\$(P1)	P1 Paint Opts		
		.S	Charcoal		
			CONTINUED...		



10330 Argonne Woods Dr, Suite 600
 Woodridge, IL 60517
 Phone: (630) 850-8700
 Fax: (630) 783-2143

Proposal

PROPOSAL: 43014

DATE: 07/01/20

PROJECT#: 732-261

PROPOSAL FOR:	INSTALL AT:
Darien Police Department 1702 Plainfield Road Darien, IL 60561	Darien Police Department 1702 Plainfield Road Darien, IL 60561

SALESPERSON

Kevin Sietsema

CUSTOMER P/O

QUOTE VALID

06/08/20

#	QTY	PRODUCT	DESCRIPTION	SELL	EXTENDED
			Tag(s): Detectives		
18	1	H36720R	Brigade Ped "R" Pull Freestanding B/B/F 20"D x 28"H	191.73	191.73
		.L	Lock: Lock		
		\$(P1)	P1 Paint Opts		
		.S	Charcoal		
			Tag(s): Detectives		
19	4	HFSC1836 40N	Flagship Stg Cab 39 1/8Hx36Wx18D N Pulls-2 Adj Shlf	445.62	1,782.48
		.L	Standard Random Key Lock		
		\$(P1)	P1 Paint Opts		
		.S	Charcoal		
			Tag(s): Detectives		
20	4	HVL705	Big & Tall High Back Mesh	329.28	1,317.12
		\$(1)	Grd 1 Uph		
		.VM	Fabric: Black		
		10	COLOR: Black		
			Tag(s): Detectives		
21	1	HTLCREDB	Preside 60 Buffet Credenza	1,091.20	1,091.20
		.G	EDGE: 2mm/Flat		
		SA	Sterling Ash		
			CONTINUED...		



10330 Argonne Woods Dr, Suite 600
 Woodridge, IL 60517
 Phone: (630) 850-8700
 Fax: (630) 783-2143

Proposal

PROPOSAL: 43014

DATE: 07/01/20

PROJECT#: 732-261

PROPOSAL FOR:	INSTALL AT:
Darien Police Department 1702 Plainfield Road Darien, IL 60561	Darien Police Department 1702 Plainfield Road Darien, IL 60561

SALESPERSON

Kevin Sietsema

CUSTOMER P/O

QUOTE VALID

06/08/20

#	QTY	PRODUCT	DESCRIPTION	SELL	EXTENDED
		\$(L1STD) .LSA1	Grd L1 Standard Laminates Sterling Ash		
		\$(L1STD) .LSA1 .3	Grd L1 Standard Laminates Sterling Ash Pull:Rounded SquareMatteChrome		
			Tag(s): Detectives		
22	2	H36720R	Brigade Ped "R" Pull Freestanding B/B/F 20"D x 28"H	191.73	383.46
		.L \$(P1) .S	Lock: Lock P1 Paint Opts Charcoal		
			Tag(s): Evidence		
23	4	HHN83112 4	Flat Bracket 24D	21.12	84.48
		.S	Color: Charcoal		
			Tag(s): Evidence		
24	2	HSDDL29	29.5"H Corner Desk Leg	54.45	108.90
		\$(P1) .S	P1 Paint Opts Charcoal		
			Tag(s): Evidence		
25	3	HSDEP112 9F	11"D End-Panel Supports: Freestanding	60.39	181.17
			CONTINUED...		



10330 Argonne Woods Dr, Suite 600
 Woodridge, IL 60517
 Phone: (630) 850-8700
 Fax: (630) 783-2143

Proposal

PROPOSAL: 43014

DATE: 07/01/20

PROJECT#: 732-261

PROPOSAL FOR:	INSTALL AT:
Darien Police Department 1702 Plainfield Road Darien, IL 60561	Darien Police Department 1702 Plainfield Road Darien, IL 60561

SALESPERSON
Kevin Sietsema

CUSTOMER P/O

QUOTE VALID
06/08/20

#	QTY	PRODUCT	DESCRIPTION	SELL	EXTENDED
		\$(P1) .S	P1 Paint Opts Charcoal Tag(s): Evidence		
26	2	HSDEP242 9F	24'D End-Panel Supports: Freestanding	64.02	128.04
		\$(P1) .S	P1 Paint Opts Charcoal Tag(s): Evidence		
27	6	HSDG	Gussets (1 Pr)	37.62	225.72
		\$(P1) .S	P1 Paint Opts Charcoal Tag(s): Evidence		
28	1	HWR2424P N	Systems Rectanular Wksfc Edgeband 24D X 24W No Grom	100.65	100.65
		\$(L1STD) .LSA1 .SA	Grd L1 Standard Laminates Sterling Ash Sterling Ash Tag(s): Evidence		
29	1	HWR2430P	Systems Rectangular Worksurface Edgeband 24D x 30W	105.60	105.60
		\$(L1STD)	Grd L1 Standard Laminates CONTINUED...		



10330 Argonne Woods Dr, Suite 600
 Woodridge, IL 60517
 Phone: (630) 850-8700
 Fax: (630) 783-2143

Proposal

PROPOSAL: 43014

DATE: 07/01/20

PROJECT#: 732-261

PROPOSAL FOR:	INSTALL AT:
Darien Police Department 1702 Plainfield Road Darien, IL 60561	Darien Police Department 1702 Plainfield Road Darien, IL 60561

SALESPERSON

Kevin Sietsema

CUSTOMER P/O

QUOTE VALID

06/08/20

#	QTY	PRODUCT	DESCRIPTION	SELL	EXTENDED
		.LSA1	Sterling Ash		
		.SA	Sterling Ash		
		.S	Grommet: Charcoal		
			Tag(s): Evidence		
30	1	HWR2442P	Systems Rectangular Worksurface Edgeband 24D x 42W	125.40	125.40
		\$(L1STD)	Grd L1 Standard Laminates		
		.LSA1	Sterling Ash		
		.SA	Sterling Ash		
		.S	Grommet: Charcoal		
			Tag(s): Evidence		
31	1	HVV93AAL P	Systems 72x36x24x24Left Corner Cove Worksurface Edgebd	220.44	220.44
		\$(L1STD)	Grd L1 Standard Laminates		
		.LSA1	Sterling Ash		
		.SA	Sterling Ash		
		.S	Grommet: Charcoal		
			Tag(s): Evidence		
32	1	HVV93AAR P	Systems 72x36x24x24Rt Corner Cove Worksurface Edgeband	220.44	220.44
		\$(L1STD)	Grd L1 Standard Laminates		
		.LSA1	Sterling Ash		
		.SA	Sterling Ash		
		.S	Grommet: Charcoal		
			CONTINUED...		



10330 Argonne Woods Dr, Suite 600
 Woodridge, IL 60517
 Phone: (630) 850-8700
 Fax: (630) 783-2143

Proposal

PROPOSAL: 43014

DATE: 07/01/20

PROJECT#: 732-261

PROPOSAL FOR:	INSTALL AT:
Darien Police Department 1702 Plainfield Road Darien, IL 60561	Darien Police Department 1702 Plainfield Road Darien, IL 60561

SALESPERSON
Kevin Sietsema

CUSTOMER P/O

QUOTE VALID
06/08/20

#	QTY	PRODUCT	DESCRIPTION	SELL	EXTENDED
			Tag(s): Evidence		
33	1	HFMSC182 830RWB	Modular Storage Cabinet 18"D x 28"H x 30"W	434.70	434.70
		.L	Standard Random Key Lock		
		.G	Glide		
		\$(P1)	P1 Paint Opts		
		.S	Charcoal		
			Tag(s): Evidence		
34	1	HFSC1836 40R	Flagship Stg Cab 39 1/8Hx36Wx18D R Pulls-2 Adj Shlf	445.62	445.62
		.L	Standard Random Key Lock		
		\$(P1)	P1 Paint Opts		
		.S	Charcoal		
			Tag(s): Evidence		
35	2	HVL705	Big & Tall High Back Mesh	329.28	658.56
		\$(1)	Grd 1 Uph		
		.VM	Fabric: Black		
		10	COLOR: Black		
			Tag(s): Evidence		
36	6	HPWRMOD2 UWM	2 Receptacle 2 USB Under-Wrksf Mount	168.41	1,010.46
		...	Skipped Option		
			CONTINUED...		



10330 Argonne Woods Dr, Suite 600
 Woodridge, IL 60517
 Phone: (630) 850-8700
 Fax: (630) 783-2143

Proposal

PROPOSAL: 43014

DATE: 07/01/20

PROJECT#: 732-261

PROPOSAL FOR:	INSTALL AT:
Darien Police Department 1702 Plainfield Road Darien, IL 60561	Darien Police Department 1702 Plainfield Road Darien, IL 60561

SALESPERSON

Kevin Sietsema

CUSTOMER P/O

QUOTE VALID

06/08/20

#	QTY	PRODUCT	DESCRIPTION	SELL	EXTENDED
37	1	HF22	Master Key (One Key)	10.90	10.90
38	3	HF23S	Contain Satin Removable Lock Core Kit	17.44	52.32
		.X101E	KEY NUMBER: 101E		
39	3	HF23S	Contain Satin Removable Lock Core Kit	17.44	52.32
		.X102E	KEY NUMBER: 102E		
40	3	HF23S	Contain Satin Removable Lock Core Kit	17.44	52.32
		.X103E	KEY NUMBER: 103E		
41	3	HF23S	Contain Satin Removable Lock Core Kit	17.44	52.32
		.X104E	KEY NUMBER: 104E		



10330 Argonne Woods Dr, Suite 600
 Woodridge, IL 60517
 Phone: (630) 850-8700
 Fax: (630) 783-2143

Proposal

PROPOSAL: 43014

DATE: 07/01/20

PROJECT#: 732-261

PROPOSAL FOR:	INSTALL AT:
Darien Police Department 1702 Plainfield Road Darien, IL 60561	Darien Police Department 1702 Plainfield Road Darien, IL 60561

SALESPERSON

Kevin Sietsema

CUSTOMER P/O

QUOTE VALID

06/08/20

#	QTY	PRODUCT	DESCRIPTION	SELL	EXTENDED
42	2	HF23S	Contain Satin Removable Lock Core Kit	17.44	34.88
		.X105E	KEY NUMBER: 105E		
43	2	HF23S	Contain Satin Removable Lock Core Kit	17.44	34.88
		.X106E	KEY NUMBER: 106E		
44	4	4168BL	Safco Coat Racks	80.00	320.00
45	1	Labor	Receive, Deliver & Install - Normal Business Hours	2,250.00	2,250.00



Installation available from Midwest Office Interiors
 Thank you for the opportunity!

SUBTOTAL.....: 14,745.71

DEPOSIT REQUIRED: 8,498.00

INSTALL.....: 2,250.00

ACCEPTED BY _____

DATE ACCEPTED _____

TOTAL -----
 16,995.71
 =====

AGENDA MEMO

City Council

August 3, 2020

ISSUE STATEMENT

A resolution authorizing the purchase of (1) dual purpose canine (K9) unit and four week training class from Northern Michigan K9 Inc. using Department of Justice (DOJ) award money in the amount of \$11,500.

RESOLUTION

BACKGROUND/HISTORY

Our current K9 dog (Niko) is nearing the end of his career and the Department would like to supplement our current K9 officer until it is appropriate that Niko retires. Staff recommends purchasing a new K9 dog from Northern K9 Inc. The dogs that are trained through this program all have great temperaments. Northern K9 Inc. has 15 years of experience training dogs exclusively for police agencies. They're the only training facility staffed with working K9 officers.

The Darien Police Department is a proud participant in the United States Department of Justice and the United States Department of Treasury Equitable Sharing Program for State and Local Law Enforcement Agencies. For the last two years the Darien Police Department has participated in federal task forces whose goal is to stem the flow of illegal narcotics into the Chicago metropolitan area which is one of the major hubs for illegal narcotics coming into the United States. It is the goal of this program to not only cut off the flow of illegal narcotics into the area, but to take away and use the tools, proceeds and property derived from any criminal activity against the offenders. These seized tools, proceeds and property are ultimately a deterrent to criminal activity and an enhancement to law enforcement. Under the Guidelines of the Equitable Sharing Program, the funds received cannot be used to replace or supplant the police department's regularly budgeted monies but augment the police budget. These seized monies may only be used by the police department in order to augment the police budget. This purchase meets the Guidelines of the Equitable Sharing Program and will provide an important tool for the police department that otherwise would not be available without participation in the Equitable Sharing Program. The cash balance of this fund is \$383,076.40 as of June 30, 2020.

COMMITTEE RECOMMENDATION

Committee recommends purchasing this K9 unit and training class from Northern Michigan K9 Inc. using Department of Justice award money in the amount of \$11,500.

ALTERNATE CONSIDERATION

As recommended.

DECISION MODE

This item will be placed on the August 3, 2020 agenda for formal Council consideration and approval.



RESOLUTION NO. _____

A RESOLUTION AUTHORIZING THE PURCHASE OF (1) DUAL PURPOSE CANINE (K9) UNIT AND A FOUR WEEK TRAINING CLASS FROM NORTHERN MICHIGAN K9 INC. USING DEPRMENT OF JUSTICE AWARD MONEY IN THE AMOUNT OF \$11,500

BE IT RESOLVED BY THE CITY COUNCIL OF THE CITY OF DARIEN, DU PAGE COUNTY, ILLINOIS, as follows:

SECTION 1: The City Council of the City of Darien hereby authorizes the City Administrator to purchase (1) Dual Purpose K9 Unit and four week training class from Northern Michigan K9 Inc. using Department of Justice award money in the amount of \$11,500, attached hereto as "**Exhibit A**".

SECTION 2: This Resolution shall be in full force and effect from and after its passage and approval as provided by law.

PASSED BY THE CITY COUNCIL OF THE CITY OF DARIEN, DU PAGE COUNTY, ILLINOIS, this 3rd day of August, 2020.

AYES: _____

NAYS: _____

ABSENT: _____

APPROVED BY THE MAYOR OF THE CITY OF DARIEN, DU PAGE COUNTY, ILLINOIS, this 3rd day of August, 2020.

JOSEPH A. MARCHESE, MAYOR

ATTEST:

JOANNE E. RAGONA, CITY CLERK

APPROVED AS TO FORM:

CITY ATTORNEY

Northern Michigan K9

1820 S. Coolidge Ave. Harrison
Mi. 48625

Invoice, 06-18-20

Darien Police department
1710 Plainfield Rd
Darien, IL 60561

BALANCE DUE
Upon Receipt

Notes: Class date September 7th 2020

Item Description	Quantity	Price Per	Total
Dual purpose K9 and 4 week class	1	\$11,500	\$11,500
Thank you again for contacting NMK9		Subtotal	
		Tax - 0%	
		TOTAL	\$11,500

AGENDA MEMO
City Council
August 3, 2020

ISSUE STATEMENT

Approval of an ordinance authorizing the sale or disposal of surplus property.

ORDINANCE

BACKGROUND/HISTORY

Staff is requesting that the following property be declared as surplus property and auctioned using an on-line auction service, LiquidityServices.com, or disposed of:

ITEM	EXPLANATION
1 Brinks Safe (no key)	No longer useful to the City
2 (2) Centrios Camcorder Bags	No longer needed
3 Cent-O-Gram Scale	No longer needed
4 Alpha Lock 2000 Vehicle Wheel Lock	No longer needed
5 Passive Night Vision System Star-Trow MK 303A	No longer needed
6 Garmin Nuvi 2595 LMT Blue Tooth Navigation	No longer useful to the City
7 (1) Bounty Hunter Metal Detector	No longer useful to the City
8 Olympus Digital Voice Recorder	No longer needed
9 Dell Keyboard	No longer useful to the City
10. Lenovo Keyboard	No longer useful to the City
11. Pentax Binoculars	No longer useful to the City
12. Pik Stik	No longer needed
13. Pelican 1600 Case	No longer useful to the City
14. Portable Video Player PV330	No longer useful to the City
15. GE USB 2.0 HUB	No longer functional
16. Mr. Coffee Coffeemaker	No longer useful to the City
17. 2006 Chevy Tahoe – Brown	No longer needed
18. 2012 Chevy Tahoe	No longer useful to the City
19. (4) Metal Desks	No longer needed
20. (3) Metal Book Case with (3) Shelves	No longer needed
21. (1) Metal Book Case with (4) Shelves	No longer needed
22. (1) 2 x 3 Brown Laminate Top Table	No longer needed
23. (2) Drawer Rolling Filing Cabinets	No longer needed
24. (4) Swivel Office Chairs	No longer needed
25. (2) Black Coat Racks	No longer needed
26. (1) 3 Shelf Book Case	No longer needed
27. (1) Small Wood Desk Computer	No longer useful to the City
28. (1) 2007 Crown Victoria	No longer needed
29. (2) 8 ft. Steel File Cabinets with Doors	No longer needed

Staff recommends the above be declared surplus property and disposed of or auctioned using GovDeals.com.

ALTERNATE CONSIDERATION

As recommended.

DECISION MODE

This item will be placed on the August 3, 2020 City Council Agenda for formal approval.



CITY OF DARIEN

DU PAGE COUNTY, ILLINOIS

ORDINANCE NO. _____

**AN ORDINANCE AUTHORIZING THE SALE
OF PERSONAL PROPERTY
OWNED BY THE CITY OF DARIEN**

**ADOPTED BY THE
MAYOR AND CITY COUNCIL**

OF THE

CITY OF DARIEN

THIS 27th DAY OF AUGUST, 2020

**Published in pamphlet form by authority
of the Mayor and City Council of the City
of Darien, DuPage County, Illinois, this
_____ day of August, 2020.**

ORDINANCE NO. _____

**AN ORDINANCE AUTHORIZING THE SALE
OF PERSONAL PROPERTY
OWNED BY THE CITY OF DARIEN**

WHEREAS, in the opinion of at least three fourths of the corporate authorities of the City of Darien, it is no longer necessary or useful, or for the best interests of the City of Darien, to retain ownership of the personal property hereinafter described; and

WHEREAS, it has been determined by the Mayor and City Council of the City of Darien to sell said personal property at a Public Auction or dispose of said property.

NOW, THEREFORE, BE IT ORDAINED BY THE CITY COUNCIL OF THE CITY OF DARIEN, DU PAGE COUNTY, ILLINOIS, IN THE EXERCISE OF ITS HOME RULE POWERS, as follows:

SECTION 1: The Mayor and City Council of the City of Darien find that the following described personal property, now owned by the City of Darien, is no longer necessary or useful to the City of Darien and the best interests of the City of Darien will be served by auctioning it using Public Surplus or disposing of said property.

ITEM	EXPLANATION
1 Brinks Safe (no key)	No longer useful to the City
2 (2) Centrios Camcorder Bags	No longer needed
3 Cent-O-Gram Scale	No longer needed
4 Alpha Lock 2000 Vehicle Wheel Lock	No longer needed
5 Passive Night Vision System Star-Trow MK 303A	No longer needed
6 Garmin Nuvi 2595 LMT Blue Tooth Navigation	No longer useful to the City
7 (1) Bounty Hunter Metal Detector	No longer useful to the City
8 Olympus Digital Voice Recorder	No longer needed
9 Dell Keyboard	No longer useful to the City
10. Lenovo Keyboard	No longer useful to the City
11. Pentax Binoculars	No longer useful to the City
12. Pik Stik	No longer needed

ORDINANCE NO. _____

13. Pelican 1600 Case	No longer useful to the City
14. Portable Video Player PV330	No longer useful to the City
15. GE USB 2.0 HUB	No longer functional
16. Mr. Coffee Coffeemaker	No longer useful to the City
17. 2006 Chevy Tahoe – Brown	No longer needed
18. 2012 Chevy Tahoe	No longer useful to the City
19. (4) Metal Desks	No longer needed
20. (3) Metal Book Case with (3) Shelves	No longer needed
21. (1) Metal Book Case with (4) Shelves	No longer needed
22. (1) 2 x 3 Brown Laminate Top Table	No longer needed
23. (2) Drawer Rolling Filing Cabinets	No longer needed
24. (4) Swivel Office Chairs	No longer needed
25. (2) Black Coat Racks	No longer needed
26. (1) 3 Shelf Book Case	No longer needed
27. (1) Small Wood Desk Computer	No longer useful to the City
28. (1) 2007 Crown Victoria	No longer needed
29. (2) 8 ft. Steel File Cabinets with Doors	No longer needed

SECTION 2: The City Administrator is hereby authorized and directed to sell the aforementioned personal property, now owned by the City of Darien. Items will be auctioned using Public Surplus or disposing of said property.

SECTION 3: This Ordinance and each of its terms shall be the effective legislative act of a home rule municipality without regard to whether such Ordinance should (a) contain terms contrary to the provisions of current or subsequent non-preemptive state law, or (b) legislate in a manner or regarding a matter not delegated to municipalities by state law. It is the intent of the corporate authorities of the City of Darien that to the extent that the terms of this Ordinance should be inconsistent with any non-preemptive state law, that this Ordinance shall supersede state law in that regard within its jurisdiction.

SECTION 4: This Ordinance shall be in full force and effect from and after its passage and approval as provided by law.

ORDINANCE NO. _____

PASSED BY THE CITY COUNCIL OF THE CITY OF DARIEN, DU PAGE COUNTY, ILLINOIS, this 3rd day of August, 2020.

AYES: _____

NAYS: _____

ABSENT: _____

APPROVED BY THE MAYOR OF THE CITY OF DARIEN, DU PAGE COUNTY, ILLINOIS, this 3rd day of August, 2020.

JOSEPH A. MARCHESE, MAYOR

ATTEST:

JOANNE E. RAGONA, CITY CLERK

APPROVED AS TO FORM:

CITY ATTORNEY



AGENDA MEMO
City Council
August 3, 2020

ISSUE STATEMENT

A motion to approve the expenditure of budgeted funds to purchase professional consulting services from Resource Management in the amount of \$9,225.

BACKUP

BACKGROUND/HISTORY

The current eligibility list for promotion from officer to sergeant will expire November 14, 2020. We have promoted one officer from the current eligibility list. The Fire and Police Commission, Rules and Regulations, established the eligibility list to expire after three years. In order to have a list of eligible officers for promotion we need to establish a list. The establishing of a list of qualified officers for the potential need for promotion to sergeant is needed in case of retirement of any of the current supervisors over the next three years. To conduct a valid defensible list an outside agency is required to conduct a written examination and structured oral interview. Those two weighted tests in combination with weighted merit rating and seniority points will establish a list.

Item	FYE21 Budget	Actual Cost
Boards & Commissions Professional Consulting Services	\$10,000 – Line 01-40-4205	\$10,250.00

Proposals/Bids

Resorce Management Associates	\$9,225
Stanard & Associates	\$9,885
Testing for Public Safety	\$10,050
IO Solutions Inc.	\$20,075

STAFF/COMMITTEE RECOMMENDATION

Committee recommends a motion to approve the expenditure of budgeted funds to purchase professional consulting services from Resource Management Association in the amount of \$9,225.

ALTERNATE CONSIDERATION

As recommended.

DECISION MODE

This item will be placed on the August 3, 2020 City Council agenda for formal approval.



June 23, 2020

Ms. Rosemary Gonzalez
Administrative Services Manager
Darien Police Department
1710 Plainfield Road
Darien IL 60561

Dear Ms. Gonzalez:

Per your request, I am submitting this proposal to test candidates for the position of Sergeant. More specifically, the process will consist of a customized written examination as well as an assessment center. **Resource Management Associates** has nearly 40 years of experience in the design and administration of customized promotional examinations for the fire and police service, and I am confident that we can develop a promotional process that will prove satisfactory to you and that will withstand the most rigorous scrutiny.

In the design and administration of fire and police department promotional examinations, we consider the following to be of paramount importance.

1. The examination should be valid and relevant. That is, it should be based upon a thorough understanding of the position for which candidates are being considered and should accurately measure a candidate's potential for successfully performing the duties of the position.
2. The process should be designed in such a way as to provide every eligible applicant a fair and equal opportunity to demonstrate his or her ability to perform the duties of the position and there should be absolutely no hint of bias, favoritism or personal influence in any part of the examination process.
3. The process should be legally defensible and free from any actual or implied adverse impact against any person or group on the basis of age, gender, race, color, or creed.
4. The process should be cost-effective. While quality should not be sacrificed to cut costs, the costs of the service provided should be justified on the basis of the quality of the final work product.

5. The integrity and credibility of the testing firm, as well as that of the Department, should not be questioned as a result of the testing process.

These are the principles that have guided us over the years in our design and administration of public safety promotional examinations. We hope that you will agree that these principles are important in evaluating our approach to this undertaking.

Scope of Services

Based upon my understanding of your requirements, we are prepared to do the following:

Police Sergeant

Written Examination

1. We will consult with Chief Thomas or his designee to identify the source materials to be included on the written examination. All books and reference materials can be obtained from local libraries, Amazon or book stores. If desired, we will also include questions from the police department's Policies and Procedures or comparable document(s). We recommend that sixty days be allowed from the time the reading list is posted until the date of the written examination to allow candidates to obtain and study the reference materials. I have included our overall Source List for your review.
2. We will design an objective, job-related and content-valid written examination for this position based upon contemporary source materials on appropriate technical subjects as well as supervisory principles and practices.
3. We will administer the examination in accordance with commonly-accepted examination procedures at the time and place designated by the Department. We will score the examination on-site using computerized scoring methods and provide a written report to the candidates containing their score as well as a list of the items they answered incorrectly. We will subsequently provide the Department a list of scores attained by the candidates on the written examination.
4. We will provide candidates an opportunity to review their test results immediately after the examination and to challenge any questions they may believe to be vague, ambiguous, or capable of being answered more than one way. We will review each appeal and make an independent ruling to be forwarded to you in writing. Where necessary, will re-score the written examination and provide you with a copy of the revised scores within one week.

Assessment Center

1. We will develop and administer an assessment center for this position to consist of three exercises designed to reflect the organization, operations and policies of the Darien Police Department and the duties and responsibilities of the position of a Sergeant.
2. We will obtain three persons to serve as assessors. These will be persons who have substantial experience in police department management and supervision; have no knowledge of any of the candidates and have no direct connection with the Darien Police Department.
3. Prior to the assessment center, we will provide the assessors with detailed information regarding the position as well as copies of all exercise materials and candidate scoring procedures. We will also conduct an orientation and training session for the assessors to provide them with more in-depth information about the procedures to be employed in evaluating and scoring the candidates. Assessors will also be provided with background information concerning the organization, staffing and operations of the Darien Police Department.
4. Prior to the assessment center, we will conduct an orientation session for the candidates to acquaint them with the nature of the process, the exercises in which they will participate, and the manner in which their performance will be evaluated.
5. We will be responsible for administering the assessment center and providing all necessary candidate briefing materials, assessor instructions and rating forms.
6. We propose that the assessment center, including the candidate evaluation and scoring by the assessors, be video recorded to document the consistency in the process and fairness to all candidates. The video recordings can then be used to review the performance of the candidates in the exercises.
7. Within one week following the assessment center, we will provide you with a final report on the assessment center and a list of scores obtained by the candidates. Scores shall be based on a maximum 100 percent.
8. Within 30 days following the assessment center, we will conduct individual feedback sessions with the candidates to advise them of their strengths and weaknesses and how their performance might be improved in the future.

Project Administration

The project would be conducted under the supervision of **Mr. Charles D. Hale**, who is the President of **Resource Management Associates** and has served in that capacity since 1981. Mr. Hale has served as a consultant in law enforcement to over 300 municipalities throughout the United States since 1973 and is the author of three books on police administration. He is also the author of the chapter "Police Patrol" in the text, Local Government Police Management, published by the International City Management Association. Mr. Hale served as a Police Officer and Police Sergeant in El Segundo, California, during which time he earned a Master's Degree in Criminal Justice from California State University at Long Beach.

Charles Hale has designed and administered written examinations, oral examinations and assessment centers of the type described herein for police, fire and public safety departments throughout the United States. His clients have included the City and County of San Francisco, California; Tallahassee, Florida; Providence, Rhode Island; Madison, Wisconsin; Rockford, Illinois; and numerous municipalities in the Chicago area. Mr. Hale is the author of the text, The Assessment Center Handbook for Police and Fire Personnel, published by Charles C. Thomas Publishers of Springfield, Illinois.

Mr. Steven W. Hale is the Vice-President of **Resource Management Associates**. Steven Hale has more than 30 years of experience in designing and administering customized written promotional examinations, oral examinations and assessment centers. Mr. Hale attended Joliet Junior College in pursuit of an education degree prior to joining **Resource Management Associates**. During his tenure with the firm, Mr. Hale has designed and administered several hundred testing assignments for various positions throughout several states.

Resource Management Associates also utilizes dozens of police and fire practitioners from various regions of the country to serve as Project Managers, Test Administrators and evaluators, for the examinations we administer for our clients. These individuals have extensive practical experience in the field of public safety and have outstanding professional reputations to serve in this capacity. These persons are employed as needed to ensure the successful completion of each testing endeavor we administer.

Organizational Qualifications

Resource Management Associates has 40 years of experience in the design and administration of customized promotional examinations for the police, fire and public safety agencies. **Resource Management Associates** is one of the leading providers of police and fire promotional examination services in the United States. We have designed and administered promotional examinations for communities in several states. Since 1981, we have established a reputation for professional work and client satisfaction.

Each year we design and administer more than 100 customized promotional examinations for police and fire departments in several states (*see below*). We have designed and administered written examinations, oral examinations and assessment centers for public safety departments in more than 25 states, including Alabama, Arizona, California, Colorado, Connecticut, Florida, Georgia, Illinois, Indiana, Iowa, Kansas, Kentucky, Maine, Maryland, Massachusetts, Michigan, Mississippi, Missouri, Nebraska, New Hampshire, Ohio, Pennsylvania, Rhode Island, South Carolina, Vermont, Wisconsin, and Wyoming. Over the last fifteen years we have conducted over 1,000 customized and content-valid promotional examinations for a wide range of ranks in the police and fire services.

You are invited to contact representatives of any of our previous clients including those listed below.

Chief Shanon Gillette
Downers Grove Police Department
Downers Grove, IL
(630) 434-5693

Ms. Debra Bush
Human Resources Coordinator
Peoria, IL
(309) 494-8578

Chief Frank Giammarese
Bloomington Police Department
Bloomington, IL
(630) 529-9868

Chief Steven Casstevens
Buffalo Grove Police Department
Buffalo Grove, IL
(847) 459-2575

Examination Fees

Written Examination:

Base Fee for customized examinations	\$ 850.00
Test Booklets and Scoring @ \$15.00/each	
New Item Development (<i>if necessary</i>) @ \$25.00/each ¹	
Test Administration	\$ 600.00
On-site Scoring w/Review and Appeal Session	\$ 250.00

Assessment Center:

Exercise Development	\$ 1,000.00
Test Administration (<i>includes candidate orientation, assessor training and assessor fees</i>)	
For up to five candidates (<i>one day</i>)	\$ 3,500.00
For up to ten candidates (<i>two days</i>)	\$ 6,000.00

¹These may be either new textbook questions or local document questions that are not currently in our item bank.

Ms. Rosemary Gonzalez
June 23, 2020 - page 6

The fees quoted above do not include staff and assessor travel, lodging (*if necessary*) and meals, which will be billed to the Department at actual cost. These costs assume that the Department will provide the necessary facilities in which to conduct the various elements of the testing process.

Conclusion

Thank you for the opportunity to submit this proposal. We would consider it a privilege to assist you in this important endeavor. If you have any questions about anything contained in this proposal, please let me know.

Sincerely,

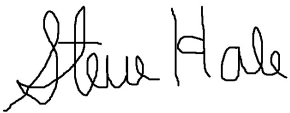
A handwritten signature in cursive script that reads "Steve Hale".

Steven W. Hale
Vice-President

Enclosure



July 9, 2020

Chief Greg Thomas
Darien Police Department
1710 Plainfield Road
Darien, IL 60561

Sent via email: gthomas@darienil.gov

Dear Chief Thomas,

Thank you for your call today regarding our promotional testing services for your upcoming Sergeant promotional process. Outlined below are the steps and costs for the written promotional exam process, as well as the structured oral board interview component.

For the purposes of this quote, for the written exam component, we are proposing our published exam, The National First Line Supervisor Test.

S&A's National First Line Supervisor Test helps law enforcement agencies identify promotional candidates who possess the relevant job knowledge to be successful supervisors and managers. The exam assesses candidates' knowledge in areas such as management/supervision, major court cases affecting law enforcement, community policing, criminal investigation, and patrol tactics. The First-Line Supervisor Test measures critical knowledge areas associated with first-line supervisor positions (e.g., Sergeant). The candidate Study Guide contains a book list outlining source material which candidates should study. Attached is a copy of the book list (separate PDF document) for your review. Our client agencies do one of three things: require candidates to obtain and purchase the books on their own, the agency purchases one set of books and keep them in the department library for candidates to access them during the test study period, or work with their local public library to source the books and then the library keeps them at their reference desk – as in-library use only publications, so that candidates can access the books when they visit the library. Most agencies provide a 45 - 60-day study period, no less than 30 days. All of the test questions are drawn from these source books. The study guide, which is approx. 15 pages, will help the candidates focus their study efforts. The study guide will give the candidates a detailed breakdown of the areas or chapters in each book that they will need to study (so they do not need to read each book cover to cover). However, they will still need the actual source books, so they can read the areas cited in the guide.



The costs for the 2020 Sergeant written exam components are as follows:

Candidate Study Guide (10 @ \$10 each).....	\$100.00*
Administration Guide	\$10.00*
Administer exam (1 S&A consultant for 1 session).....	\$500.00**
Test booklets (10 candidates @ \$100.00 each – includes scoring fee)	\$1,000.00*

Estimated project fees for the written exam based on 10 candidates sitting for this component of the testing process and administered by an S&A consultant\$1,610.00 plus shipping fees and consultant travel expenses

***these fees will be invoiced directly to the City of Darien Board of Fire and Police Commissioners by the Illinois Association of Chiefs of Police**

**** these fees will be invoiced directly to the City of Darien Board of Fire and Police Commissioners by Stanard & Associates, Inc.**

Structured Oral Board Interview Component for Sergeant

Below are the project steps and associated fees to develop an oral board interview program for your upcoming Sergeant Promotional Process, which would use external assessors (law enforcement professionals from outside agencies), recruited by S&A.

Step 1. SME Meeting: An S&A industrial/organizational psychologist will meet with the Subject Matter Expert panel from Darien PD and BOFPC to establish the important dimensions for the job, and develop five questions to assess the dimensions and review the scoring criteria. Meeting may also be conducted via web conference.

Step 2. Development of Materials: An S&A consultant will prepare the following materials that will be needed to conduct the Oral Interview Boards.

- Oral Board Rater Guidelines
- Rating Form

Step 3. Training: An S&A consultant will conduct a training session in Darien with the interview panel members (typically one panel of three assessors). Meeting may also be conducted via web conference.

- Step 4.** Administration of Oral Interview: (Optional) One S&A consultant can be on site for the administration of the oral board component. S&A expects the process to be completed in a timely manner. The number of days to complete the interviews will be determined by the number of candidates that ultimately sit for the process.
- Step 5.** Scoring: Upon completion, S&A will score the rating sheets and report the results to our authorized point of contact.

Sergeant Structured Oral Board Interview Fees

The fees to complete this work is **\$3,000.00** to conduct the SME meeting, develop five questions with scoring criteria, train the interview panel and prepare interview panel member guidelines and rating forms.

(Optional) One S&A consultant would be on site to coordinate the administration. The cost is **\$1,250.00** per day for the administrator, plus travel related expenses, tolls, mileage, meals, etc. The final number of candidates would determine the number of days needed.

S&A compensates external assessors at a rate of \$400.00 per day per assessor, plus mileage, meals and other travel expenses for their participation in the assessment process and assessor training. This is a pass through expense billed back to the City of Darien and paid by S&A directly to each assessor for their work on the project. Based on 10 candidates sitting for the oral board interview, we anticipate 3 assessors for 1.5 days which includes their time for training and the administration. Assessor fees are estimated at \$1,800.00 plus travel expenses.

If an S&A Consultant is required to be on site for the administration, the cost is \$1,250.00 per day. However, the Darien BOFPC or their designee(s) will be able to conduct the interviews without an S&A Consultant on site. This is an optional service and not included in the estimated fee total below.

If S&A scores the interviews, the cost is \$20.00 per candidate or \$200.00 for 10 candidates. We have included this fee in the estimate below.

***Estimated Oral Board Fees: \$5,000.00**

*Does not include travel related expenses, on site admin by an S&A consultant, or shipping and handling, which will be kept to a minimum and billed as incurred.



General terms:

- If needed, any additional administrative time and/or consulting (responding to candidate grievances, litigation support, expert witness testimony, depositions, statistical analyses, attend special meetings, responding to agency or candidate queries after project deliverables have been provided, etc.) will be billed at our current hourly rates which are \$175.00 per hour for Bachelor's and Master-level staff and \$250.00 per hour for Ph.D. - level staff. Requests for copies, scanning, assembly, etc. of paperwork are billed at an administration rate of \$30.00 per hour. Additional oral board interview questions can be developed at a rate of \$350.00 each.
- Any shipping and handling, printing, and travel related expenses will be kept to a minimum and billed as incurred.
- The City of Darien will be responsible for securing a location for the written test administration and/or oral board interview component.
- A contact person for this project will be designated by the City and will be responsible for coordinating activities, such as providing S&A with requested information and scheduling meetings.
- While S&A strives to become familiar with each client's local circumstances, its consultants are not attorneys, and we rely on contact personnel or client's legal counsel to ensure processes and procedures adhere to local rules (e.g. Fire and Police Commission rules, bargaining agreements, etc.)
- Work performed or meetings scheduled on weekends requiring S&A's attendance will be billed at 1.5 times any quoted project rate.
- S&A invoices for one-half payment up front and the other half upon completion.

We appreciate the opportunity to provide you with this price quote. After your review, if you have any questions or need further assistance, please do not hesitate to contact me at 800-367-6919. Thanks again for your time and consideration. We look forward to the prospect of working with your agency again on this important project.

Best regards,

A handwritten signature in black ink that reads 'Michael J. Thomason'.

Michael J. Thomason
Vice President



City of Darien, IL: Police Sergeant Promotional Process – July 2020

To accept our proposal and to authorize S&A to initiate work and carry out the project steps outlined above (or project steps associated with a portion of our proposal, please place a check next to the services listed below where you would like our assistance, sign, date and email to my attention at mike.thomason@stanard.com or fax back this page only to S&A at 312.553.0218. Thank you.

_____ Written Promotional Exam (NFLST)

_____ Structured Oral Board Interview component

Authorized Signature from the City of Darien, IL

Date

AGREEMENT

THIS AGREEMENT for professional services, dated this **24th of June 2020**, by and between the *Testing for Public Safety, LLC* (hereinafter “TPS, LLC”) and the **Darien Police Department** (hereinafter “Department”):

A. Basic Services

1. Effective **June 24, 2020**, and continuing through **June 23, 2021**, TPS shall, pursuant to the terms and conditions set forth herein, provide the Department with the professional consulting services set forth in **Exhibit A** attached hereto and made a part hereof.

B. Operation

1. The relationship between TPS and the Department shall be that of an independent contractor providing professional services.

2. TPS shall furnish, or make contact with other individuals or entities to furnish such professional, technical, or clerical services as are needed for the administration of the TPS programs. TPS shall provide for all salaries and the employer’s share of social security, worker’s compensation, and all other taxes imposed on an employer with reference to any personnel employed by TPS in relation to the performance of the terms of this Agreement.

3. All test materials developed and administered by TPS are the property of TPS, LLC. This Agreement provides for a one-time usage of test materials specifically developed for the purpose of executing this Agreement. Department agrees to respect the copyright of all TPS materials and agrees not to duplicate said materials without the expressed written consent of the Director of TPS, LLC.

4. All records kept by TPS concerning the designated programs herein shall be the property of TPS provided that the Department shall have the right to access and review the information contained in such records.

5. In the event an applicant or incumbent requires a reasonable accommodation in the administration of any test by TPS the Department agrees to pay a reasonable additional fee therefore.

6. The total cost to the Department for services of TPS as provided for in this Agreement shall be in the amount set forth in **Exhibit A**. Such amount shall be remitted to TPS within thirty (30) days after completion of the agreed services. The services rendered by TPS under this Agreement shall be considered as “professional services”. Upon request, TPS shall provide a fully itemized statement concerning the services rendered under this Agreement.

C. Additional Services

1. The Department may, from time to time, require changes in the scope of the services of TPS to be performed under this Agreement. Such changes, including any increases or decreases in the amount of compensation to TPS which are mutually agreed upon by the parties hereto, and approved by all other necessary and proper authorities, shall be incorporated in written amendments to this Agreement.

2. TPS further agrees that its personnel will appear, if necessary, to testify on behalf of the Department with regard to any legal challenge involving TPS programs, and that TPS personnel shall make such appearance without compensation other than out-of-pocket expenses.

D. Miscellaneous

1. If TPS fails to fulfill in a timely and proper manner the obligations pursuant to this Agreement, the Department shall thereupon have the right to terminate this Agreement by giving written notice to TPS at least thirty (30) days prior to the effective date of such termination. In the event of termination, neither party hereto shall be relieved of liability to the other for damages sustained by virtue of any breach of this Agreement, and the Department may withhold payment to TPS for the purpose of setoff until such time as the exact amount of damages due the Department can be determined.
2. If the Department shall fail to fulfill in a timely and proper manner the obligations pursuant to this Agreement, TPS shall thereupon have the right to terminate this Agreement. Said notice shall be given to the Department at least thirty (30) days prior to the effective date of such termination. In the event of termination, neither party hereto shall be relieved of liability to the other for damages sustained by virtue of any breach of this Agreement.
3. TPS shall indemnify and hold harmless the Department from any and all loss, damage, injury or liability caused by the negligence of TPS or its employees or agents in performing its obligations provided in this Agreement.
4. TPS shall not be held liable and the Department shall hold TPS harmless from any and all loss, damage, injury or liability caused by the negligence of the Department or its employees or agents in disregarding or ignoring any professional opinion, diagnosis or recommendation of TPS or its employees or agents while TPS is performing its obligations provided in this Agreement.
5. TPS certifies and warrants that it has the capacity to perform the services as required by the Department with high professional quality, ability and expertise and further certifies and warrants that it has the capacity and authority to enter into this Agreement.
6. TPS and its employees, agents and representatives, in the performance of this Agreement, agree not to discriminate against any employee or applicant for employment with respect to his or her tenure, terms, conditions, or privileges of employment, or any matter directly or indirectly related to employment, because of race, color, sex, religion, national origin, ancestry, disability, or Vietnam Era veteran status.
7. This Agreement shall be binding upon and shall inure to the benefit of TPS its partners, successors, assigns, legal and personal, representatives, and administrators.
8. At the expiration of the initial term hereof, or upon earlier termination of this Agreement pursuant to Section D, 4, the parties shall review the compensation paid by Department and the services rendered by TPS through the date of such termination to determine whether Department is entitled to any reimbursement or whether TPS is entitled to additional compensation, and any necessary adjustments shall be made.
9. Nothing herein shall be construed as creating any personal liability on the part of any officer, director, agent, or employee of any public body which may be a party hereto.
10. This Agreement represents the entire understanding between and among the parties hereto. This Agreement may not be changed, altered, or amended; modification of this Agreement must be in writing, executed by the parties hereto, refer to this Agreement by date, and must be executed on a form entitled "Supplemental Agreement" approved by all parties hereto.

TESTING FOR PUBLIC SAFETY, LLC

Exhibit A

Agreement with Darien Police Department For a Police Sergeant Promotion Process

Process Steps:

- I. Establish Job Relevance
 - A. Develop consolidated job descriptions via survey
 - B. Select source materials with guidance of Development Committee
- II. Train and Inform Candidates about Process
 - A. Provide candidates with descriptive process booklets
 - B. Prepare training video on test preparation
- III. Write and Validate Written Test Questions
 - A. Write test questions on all reading materials
 - B. Validate test questions via committee review before or after exam
- IV. Administer Written Test
 - A. Provide test booklets
 - B. Administer test site
 - C. Provide all testing material
- V. Conduct an Appeal/Review Session immediately after the written exam
 - A. Provide candidates with a copy of their own answer sheet and an answer key
 - B. Receive written appeals on test questions
 - C. Meet with committee afterwards to review appeals
- VI. Develop Structured Interview/Assessment Center Materials
 - A. Meet with the committee to identify assessment goals
 - B. Develop structured questions and scoring guidelines
 - C. Validate material either before or after test administration
- VII. Administer Interviews and Assessment Centers
 - A. Train oral interview board
- VIII. Score Results
 - A. Tally preliminary scores
 - B. Generate preliminary lists
 - C. Combine results with other process components (seniority, etc.)
- IX. Optional - Conduct Formal Appeal/Review Session
 - A. Provide candidates with individual exam results (missed questions, overall scores, etc.)
 - B. Provide candidates with individual interview and assessment center results (average score on each question or rating, scoring guidelines used by the boards, etc.)
 - C. Meet with candidates to receive written appeals
 - D. Collect appeals and present to development committee
 - E. Provide candidates with individual appeal results
- X. Provide Individual Feedback
 - A. Provide candidates with individual scores and rank order standing
- XI. Derive Final List
 - A. Provide Department with final scores and rank order list

Project Costs:

- I. Conduct a job analysis to determine job duties/responsibilities for validation

NO COST

- II. Orientation Meeting with Promotion Candidates (Optional)
 \$800.00 per day to provide a session of candidate training. Each session is scheduled for two to three hours. Candidate training provides a thorough description of the written exam, oral interview, and assessment exercises. Specifically, candidates will review the scoring procedures, and receive tips on how to prepare for the process.
- III. Promotion Written Exam
\$3,500.00 to provide one (1) written exam per rank level with no more than thirty (30) candidates per rank.
- A. **Additional \$500.00** if Department chooses local documents (i.e., Standard Operating Procedures, Rules and Procedures, Union Contract) for test questions.
 - B. Cost assumes that Department or candidates will purchase source materials.
 - C. Department will provide test site.
 - D. Cost for additional candidates over thirty (30) is \$50.00 per candidate.
 - E. Cost includes one (1) day of test administration. If too large a group is scheduled to take the exam, the department may elect to provide additional monitors to proctor the exam, or TPS may provide additional monitor for \$375.00 per monitor per day.
 - F. Cost includes all test materials and scoring.
 - G. **(Optional)** Department may elect to have the exam scored via computer on-site at a cost of \$1,000.00.
- IV. Conduct a Review Session immediately following the exam **NO COST**
 Candidates will have the opportunity to review their test booklet, a photocopy of their own answer sheet, and an answer key listing the correct answer and book page number. They may write appeals on questions if they disagree with the answer listed in the key.
- V. Promotion Oral Interview/Assessment Center Exercises
\$3,500.00 to provide oral interview/assessment center **per rank level** with no more than thirty (30) candidates.
- A. **Additional \$500** for board training, all test materials, scoring and interview monitor for first day. If assessments continue for multiple days, TPS monitor provided @ \$375.00 per day (after first day).
 - B. Department will provide test site.
 - C. Cost for additional candidates over thirty (30) is \$50.00 per candidate.
 - D. TPS will assist in identifying and securing assessors, in addition to all notifications and travel assistance **at no cost. However Department will directly compensate outside board of three (3) administrative level officers.** Current established rate is \$400.00 per rater for each day of assessments (\$1,200 per day). For those raters who travel from a distance and require accommodations, Department will also reimburse them for hotel accommodations. (TPS will attempt to identify raters who do not require accommodations when possible.)
- VI. Review Session for the Assessment Exercises - Delayed (Optional)
 \$1,400.00 to conduct an extensive appeal/review session scheduled for one (1) day.
- A. Cost includes extensive individual feedback for all testing phases and TPS, LLC monitor. (Feedback includes the opportunity for candidates to listen to their own assessment meeting, as recorded. Candidates would also be provided with the scoring guidelines used, which would be available during the review session)
 - B. Department will provide site for review session.
- VII. Compute candidate seniority scores based on hire dates provided by department, combine all scores, and provide feedback for candidates – NO CHARGE
- VIII. \$200.00 travel fee per trip for TPS personnel
- IX. \$150.00 per overnight stay for TPS personnel.

IN WITNESS WHEREOF, the parties have executed this Agreement.

TESTING FOR PUBLIC SAFETY, LLC

DARIEN POLICE DEPARTMENT

By: _____

By: _____

Date: _____

Date: _____

Darien, IL Custom Sergeant Exam and Assessment

Option 1: Sergeant Exam and Assessment Center (10-12 Candidates)

Project Step	Consultant Hrs.	Consulting Assoc. Hrs.	Tech. Wrtr. Hrs	Admin. Hrs.	Cost
Written Job Knowledge Examination	8	19	50	2	\$6,475
Work with SMEs to develop an examination plan that is linked to the job description, and select appropriate knowledge sources.	4				
Draft 125 multiple choice questions based on exam plan.	4		50		
Review questions with SMEs to assess job-relatedness and difficulty. Identify final 100 questions and establish appropriate cut-off score.		8			
Administer exam on-site.		5			
Score exam.		1		2	
Assist in designing/coordinating appeals process and respond to candidate appeals.		5			
Assessment Center Development	44	24	0	7	\$10,185
Design three assessment center exercises based on input from SMEs, including candidate preparation materials, scripts, and rating criteria/guidelines.	32				
Review exercises with SMEs to refine exercise details and ensure accuracy of criteria.	3				
Recruit assessors (estimated 6-9 assessors to create 3 panels)		6			
Administer the assessment center (estimated 10 candidates: 1 day, 2 staff)	8	8			
Compile assessment scores and conduct quality controls.	1	2		3	
Develop candidate feedback reports.		8		4	
Candidate Orientation Presentation	4	0	0	0	\$740
Prepare and deliver a candidate preparation/orientation presentation.	4				
Project Expenses					\$2,675
Assessor per diem (9 assessors @ \$250 for 1 day)		\$2,250			
Actor cost (1 actor for 1 day)		\$350			
Administrative costs (shipping, freight, printing)		\$75			
TOTAL PROJECT INVESTMENT					\$20,075

Schedule of Hourly Rates - IOS 2020

Category	Rate
Consultant/Industrial Psychologist	\$185/hour
Consulting Associate	\$75/hour
Technical Writer	\$70/hour
Administrative Assistant	\$35/hour

Project Notes

Client will be responsible for providing a suitable site at which to conduct exams and assessment and for lunch/refreshments on the day of the assessment.

AGENDA MEMO
City Council
August 3, 2020

ISSUE STATEMENT

Consideration to approve an ordinance amending the liquor code to expand the number of Class A liquor licenses from ten (ten) to eleven (11) and reduce the number of Class E liquor licenses from five (5) to four (4) to allow the Darien Pantry to sell alcoholic liquor in addition to existing beer and wine sales.

ORDINANCE

BACKGROUND

Mayor Marchese has received a request from Jay Kapi LLC (dba Darien Pantry) to upgrade from a Class E license, which allows for the packaged sale of beer and wine, to a Class A license, which also permits the sale of packaged liquor. Although the current owner Deveshkumar M. Nanavati only obtained the approved liquor license in 2019 with a change in ownership, Darien Pantry has operated with a Class E license for many years. The recent closing of Our Lady of Peace School allows distance requirements for alcohol sales to be reassessed, and permits such a change. Mayor Marchese as Liquor Commissioner has indicated he does not oppose the request.

There are currently ten (10) Class A licenses issued and five (5) Class E licenses issued. An ordinance has been prepared to delete one Class E license and add one Class A license.

ATTACHMENTS

- A. [Email Request for Liquor License](#)
- B. [Summary description of liquor license classes](#)
- C. [List of liquor licenses currently issued by class](#)

STAFF/COMMITTEE RECOMMENDATIONS

Staff recommends approval of the proposed ordinance. A committee recommendation was not required for the change of classification request.

ALTERNATE CONSIDERATION

As directed by the City Council.

DECISION MODE

This item will be placed on the August 3, 2020 City Council agenda for formal consideration.



MEMO

To: City of Darien,
1702 Plainfield Rd.
Darien, IL 60561

As of July 22,2020, Darien Pantry has a CLASS E LICENSE. This letter is to formally request a CLASS A LICENSE for Darien Pantry.

From: Darien Pantry
737 Plainfield Rd.
Suite 5
Dairen, IL 60561

hosts, hostesses, dancers, singers, models or other performance artists, or role playing interactions. (Ord. 0-39-94, 9-19-1994)

3-3-7: CLASSIFICATION OF LICENSES AND FEES:

3-3-7-1: CLASS A LICENSE:

- (A) A Class A license shall authorize sale at retail of alcoholic liquor in the original package but not for consumption on the premises of sale. Provided, however, that the Commissioner may authorize the licensed premises to offer liquor samples without charge to invitees as part of a promotional or advertising program. The granting of permission to give away such liquor samples shall be within the sole discretion of the Commissioner who shall be petitioned in writing to allow such a promotional or advertising activity at least three (3) days prior to the date upon which such activity is proposed to take place. It shall be unlawful for such an advertising or promotional activity to take place without the prior permission of the Commissioner. (Ord. 0-39-94, 9-19-1994)
- (B) It shall be unlawful for any person to sell or offer for sale at retail any alcoholic liquor in the original package but not for consumption on the premises of sale in the City between one minute past twelve o'clock (12:01) A.M. and seven o'clock (7:00) A.M. (Ord. 0-03-17, 4-3-2017)
- (C) The number of Class A licenses shall be ten (10). (Ord. 0-12-16, 4-4-2016)
- (D) The annual fee for a Class A license shall be one thousand five hundred dollars (\$1,500.00). (Ord. 0-39-94, 9-19-1994)

3-3-7-2: CLASS B LICENSE:

- (A) The Class B license shall authorize the sale at retail and serving of alcoholic liquor at a banquet hall or similar facility (where the predominant purpose of the premises is the holding of private or limited parties or events) only for consumption on the premises of the sale, provided such sale and serving is accessory to the main purpose of operating a banquet hall or similar facility on the premises. (Ord. 0-39-94, 9-19-1994)
- (B) It shall be unlawful for any person to sell or offer for sale at retail and it shall be unlawful to serve alcoholic liquor on the premises of such facility in the City between two o'clock (2:00) A.M. and eleven o'clock (11:00) A.M., except on Sundays when it shall be unlawful for any person to sell or offer for sale at retail and to serve alcoholic liquor on the premises of sale in the City between two o'clock (2:00) A.M. and twelve o'clock (12:00) noon. The Commissioner may extend the hours for lawful sale and service of alcoholic liquor on special occasions such as New Year's Eve. (Ord. 0-19-03, 4-21-2003)
- (C) The annual fee for a Class B license shall be two thousand dollars (\$2,000.00).
- (D) The number of Class B licenses shall be one (1). (Ord. 0-39-94, 9-19-1994)

3-3-7-3: CLASS C LICENSE:

- (A) A Class C license shall authorize the sale at retail and serving of alcoholic liquor for a country club (public/semipublic/private) only for consumption on the premises of the sale, provided such sale and serving is accessory to the main purpose of operating a country club on the premises. Serving of alcoholic liquor at a counter or bar shall be allowed under a Class C license to seated customers only. (Ord. 0-39-94, 9-19-1994)
- (B) It shall be unlawful for any person to sell or offer for sale at retail and it shall be unlawful to serve alcoholic liquor in the City between one o'clock (1:00) A.M. and eleven o'clock (11:00) A.M., except on Sundays when it shall be unlawful to sell or offer for sale at retail and to serve alcoholic liquor in the City between one o'clock (1:00) A.M. and ten o'clock (10:00) A.M. The Commissioner may extend the hours for lawful sale and service of alcoholic liquor on special occasions such as New Year's Eve. (Ord. 0-24-14, 7-7-2014)
- (C) The annual fee for a Class C license shall be two thousand dollars (\$2,000.00).
- (D) The number of Class C licenses shall be one (1).
- (E) Live music shall be permitted. Such music may be provided by a band, musical group or an individual playing an instrument. No person providing such music shall be under the age of eighteen (18). Such music shall be for the dancing or listening pleasure of patrons only. (Ord. 0-39-94, 9-19-1994)

3-3-7-4: CLASS D LICENSE:

- (A) A Class D license shall authorize the sale at retail and serving of alcoholic liquor at a counter or bar and at tables, provided such operation is carried on in conjunction with a restaurant operation serving a menu offering complete meals. The bar service or service at tables where a full menu is not available shall take place in a separate room from the full menu restaurant operation. (Ord. 0-39-94, 9-19-1994)
- (B) It shall be unlawful for any person to sell or offer for sale alcoholic liquor in conjunction with a Class D liquor license between one o'clock (1:00) A.M. and eleven o'clock (11:00) A.M., except on Saturdays and Sundays when it shall be unlawful for anyone to sell or offer for sale alcoholic liquor under a Class D liquor license between the hours of two o'clock (2:00) A.M. and ten o'clock (10:00) A.M. The Commissioner may extend the hours for lawful sale and service of alcoholic liquor on special occasions such as New Year's Eve. (Ord. 0-16-13, 8-5-2013)
- (C) Live music shall be permitted. Such music may be provided by a band, musical group or an individual playing an instrument. No person providing such music shall be under the age of eighteen (18). Such music shall be for the dancing or listening pleasure of patrons only. (Ord. 0-39-94, 9-19-1994)
- (D) The number of Class D licenses shall be nine (9). (Ord. 0-05-17, 4-3-2017)

(E) The annual fee for a Class D license shall be two thousand dollars (\$2,000.00). (Ord. 0-39-94, 9-19-1994)

3-3-7-5: CLASS E LICENSE:

(A) A Class E license shall authorize the sale at retail of beer and wine in original package only but not for consumption on the premises of sale. Such license shall be authorized only at such location where prepackaged food is also sold and only in such locations where there are no seats for consumption of food on the premises. (Ord. 0-18-09, 6-15-2009)

(B) It shall be unlawful for any person to sell or offer for sale at retail any beer or wine in the original package but not for consumption on the premises of sale in the City between one minute past twelve o'clock (12:01) A.M. and seven o'clock (7:00) A.M., except on Sundays when it shall be unlawful for anyone to sell or offer for sale any beer or wine at retail in the original package but not for consumption on the premises of sale between the hours of one minute past twelve o'clock (12:01) A.M. and nine o'clock (9:00) A.M. (Ord. 0-41-08, 11-17-2008)

(C) The number of Class E licenses shall be five (5). (Ord. 0-07-12, 2-21-2012)

(D) The annual fee for a Class E license shall be one thousand five hundred dollars (\$1,500.00). (Ord. 0-39-94, 9-19-1994)

3-3-7-6: CLASS F LICENSE:

(A) A Class F license shall only authorize the sale at retail of beer and wine for consumption at tables on the premises of sale provided such sale and serving is accessory to the main purpose of serving food on the premises or on a carryout basis. Beer shall be sold only by the glass or pitcher. Wine shall be sold only by glass or carafe.

(B) The serving of beer or wine for consumption while seated at a counter or bar shall not be permitted under a Class F license.

(C) Delivery of beer or wine by the license holder or his employees with carryout orders shall not be permitted under a Class F license.

(D) It shall be unlawful for any person to sell or offer for sale beer or wine in conjunction with a Class F liquor license between one o'clock (1:00) A.M. and eleven o'clock (11:00) A.M., except on Sundays when it shall be unlawful for anyone to sell or offer for sale beer or wine under a Class F liquor license between the hours of one o'clock (1:00) A.M. and twelve o'clock (12:00) noon. The Commissioner may extend the hours for lawful sale and service of beer and wine on special occasions such as New Year's Eve.

(E) A Class F liquor license, where issued, shall be for an establishment which caters principally to elementary aged schoolchildren and their families. Entertainment in the form of theatrical or musical presentations directed toward children and their families shall be permitted within

such an establishment. The use of automatic amusement devices shall be allowed at such an establishment to the extent that they are otherwise permitted by the ordinances of the City.

(F) The number of Class F licenses shall be one (1).

(G) The annual fee for a Class F license shall be one thousand five hundred dollars (\$1,500.00). (Ord. 0-39-94, 9-19-1994)

3-3-7-7: CLASS G LICENSE:

(A) A Class G license shall authorize the sale at retail of alcoholic liquor in the original package for consumption off the premises and for consumption on the premises of sale. (Ord. 0-39-94, 9-19-1994)

(B) It shall be unlawful for any person to sell or offer for sale at retail in the City between one o'clock (1:00) A.M. and eleven o'clock (11:00) A.M., except on Saturdays when it shall be unlawful for any person to sell or offer for sale at retail or serve for consumption on the premises in the City between two o'clock (2:00) A.M. and eleven o'clock (11:00) A.M. and on Sundays when it shall be unlawful for any person to sell or offer for sale at retail or serve for consumption on the premises in the City between two o'clock (2:00) A.M. and eleven o'clock (11:00) A.M. The Commissioner may extend the hours for lawful sale and service of alcoholic liquor on special occasions such as New Year's Eve. (Ord. 0-22-14, 7-7-2014)

(C) The number of Class G licenses shall be one (1).

(D) The annual fee for a Class G license shall be two thousand dollars (\$2,000.00). (Ord. 0-39-94, 9-19-1994)

3-3-7-8: CLASS H LICENSE:

(A) A Class H license shall authorize the sale at retail of alcoholic liquor for consumption on the premises and the sale at retail of beer and wine in original package but not for consumption on the premises of sale, provided such sale and serving is accessory to the main purpose of the sale of food on a carryout basis.

(B) It shall be unlawful for any person to sell or offer for sale at retail in the City between one o'clock (1:00) A.M. and eleven o'clock (11:00) A.M., except on Sundays when it shall be unlawful for any person to sell or offer for sale at retail or serve for consumption on the premises in the City between one o'clock (1:00) A.M. and twelve o'clock (12:00) noon. The Commissioner may extend the hours for lawful sale and service of alcoholic liquor on special occasions such as New Year's Eve. (Ord. 0-39-94, 9-19-1994)

(C) The number of Class H licenses shall be two (2). (Ord. 0-12-17, 7-17-2017)

(D) The annual fee for a Class H license shall be two thousand five hundred dollars (\$2,500.00). (Ord. 0-39-94, 9-19-1994)

3-3-7-9: CLASS I LICENSE:

- (A) A Class I license shall authorize the sale at retail of alcoholic liquor for consumption on the premises, provided such sale and serving is accessory to the main purpose of operating an approved amusement premises for which all permits have been previously granted by the City Council. (Ord. 0-39-94, 9-19-1994)
- (B) It shall be unlawful for any person to sell or offer to sell at retail or serve for consumption on the premises alcoholic liquor in the City between one o'clock (1:00) A.M. and eleven o'clock (11:00) A.M., except on Saturdays when it shall be unlawful for any person to sell or offer for sale at retail or serve for consumption on the premises in the City between two o'clock (2:00) A.M. and eleven o'clock (11:00) A.M., and on Sundays when it shall be unlawful for any person to sell or offer for sale at retail or serve for consumption on the premises in the City between two o'clock (2:00) A.M. and twelve o'clock (12:00) noon. The Commissioner may extend the hours for lawful sale and service of alcoholic liquor on special occasions such as New Year's Eve. (Ord. 0-41-08, 11-17-2008)
- (C) The number of Class I licenses shall be one (1).
- (D) The annual fee for a Class I license shall be two thousand five hundred dollars (\$2,500.00). (Ord. 0-39-94, 9-19-1994)

3-3-7-10: CLASS J LICENSE:

Temporary license, daily fee.

- (A) A Class J license shall authorize the sale at retail of alcoholic liquor for consumption only at the location and on the specified dates designated for the special event in the license. Such temporary liquor licenses may be granted to organizations and clubs such as, but not limited to, veterans' organizations, educational, fraternal, political, civic, religious or other nonprofit organizations.
- (B) A Class J license shall be granted on a day to day basis, but not to exceed three (3) consecutive days. The Class J license shall authorize the sale of alcoholic liquor for consumption only at the location until twelve o'clock (12:00) midnight on Friday and Saturday and until nine o'clock (9:00) P.M. on Sunday. An applicant for a temporary liquor license must submit with the application proof satisfactory to the Commissioner that the applicant shall provide dramshop liability insurance in the maximum limits. (Ord. 0-27-16, 8-1-2016)
- (C) The fee for a Class J license shall be fifty dollars (\$50.00) per day. (Ord. 0-39-94, 9-19-1994)

3-3-7-11: CLASS K LICENSE:

- (A) A Class K license shall authorize the sale at retail of beer and wine for consumption on the premises of sale or at tables, provided such sale and serving is accessory to the main purpose of serving food on the premises or on a carryout basis.

(B) It shall be unlawful for any person to sell or offer for sale beer or wine in conjunction with a Class K liquor license between one o'clock (1:00) A.M. and eleven o'clock (11:00) A.M., except Sundays when it shall be unlawful for anyone to sell or offer for sale beer or wine under a Class K liquor license between the hours of one o'clock (1:00) A.M. and twelve o'clock (12:00) noon. The Commissioner may extend the hours for lawful sale and service of beer and wine on special occasions such as New Year's Eve. (Ord. 0-39-94, 9-19-1994)

(C) The number of Class K licenses shall be four (4). (Ord. 0-24-16, 7-18-2016)

(D) The annual fee for a Class K license shall be one thousand five hundred dollars (\$1,500.00). (Ord. 0-39-94, 9-19-1994)

3-3-7-12: CLASS L LICENSE:

(Rep. by Ord. 0-37-12, 10-15-2012)

3-3-7-13: CLASS M LICENSE:

(A) A Class M license shall authorize the sale at retail and serving of alcoholic liquor at a counter or bar and at tables in premises operated by a nonprofit organization for members of the organization, their guests, and public patrons. The sale and consumption of alcoholic liquor shall be limited to the premises.

(B) It shall be unlawful for any person to sell or offer for sale alcoholic liquor in conjunction with a Class M liquor license between eleven o'clock (11:00) P.M. and eleven o'clock (11:00) A.M. The Commissioner may extend the hours for lawful sale and service of alcoholic liquor on special occasions such as New Year's Eve.

(C) The number of Class M licenses shall be one. (Ord. 0-12-18, 5-7-2018)

(D) The annual fee for a Class M license shall be one thousand dollars (\$1,000.00).

(E) All proceeds and profits made pursuant to the operation of a business activity under this license shall be for a lawful nonprofit organization. No officer or owner of any licensee under this section shall individually receive any remuneration or compensation from the business activities pursuant to this license. (Ord. 0-26-13, 10-7-2013)

3-3-7-14: CLASS N LICENSE:

(A) A Class N license shall authorize the on premises consumption and retail sale of craft beer where the premises is that of a brewing facility. For the purposes of this subsection, "brewing facility" is defined as a place in which the primary business is the manufacturing, packaging, distribution, sale and storage of craft beer produced on the premises in compliance with Federal and State laws. The following regulations shall apply to the Class N license:

1. No more than a total of fifty thousand (50,000) gallons of beer shall be sold at retail in growlers, cans and/or bottles for off premises consumption per year.

2. All growlers, cans and beers sold at retail for off premises consumption must be properly sealed.
3. Retail sales for off premises consumption and on premises consumption shall be limited to the retail portion of the licensed premises; except, however, on premises consumption may be allowed in other areas of the licensed premises during supervised tours and private events. The retail portion of the licensed premises shall not exceed three thousand (3,000) square feet.
4. Product sampling shall be permitted in accordance with State law, at no charge.
5. Patrons under twenty one (21) years of age shall be allowed on the premises when accompanied by a person twenty one (21) years of age or older; except, however, classes and seminars on alcoholic related subjects shall only be open to patrons twenty one (21) years and older.
6. Live entertainment is restricted to the indoor retail portion of the premises; except, however, live entertainment may be permitted in other indoor areas of the licensed premises during private events. (Ord. 0-34-14, 11-3-2014)

(B) It shall only be lawful to sell at retail or offer for sale at retail craft beer in conjunction with a Class N liquor license for off premises and/or on premises consumption between twelve o'clock (12:00) noon and eleven o'clock (11:00) P.M., Sunday through Saturday. Except, however, private events shall not be restricted to the above hours. For private events it shall be unlawful to sell or serve craft beer between the hours of one o'clock (1:00) A.M. and eleven o'clock (11:00) A.M., except on Saturdays and Sundays when it shall be unlawful for anyone to sell or serve craft beer between the hours of two o'clock (2:00) A.M. and ten o'clock (10:00) A.M. The Commissioner may extend the hours of lawful sale or service of craft beer on special occasions such as New Year's Eve. (Ord. 0-16-16, 5-16-2016)

(C) The number of Class N licenses shall be one.

(D) The annual fee for a Class N license shall be two thousand dollars (\$2,000.00). (Ord. 0-34-14, 11-3-2014)

3-3-7-15: CLASS O LICENSE:

(A) A Class O license shall authorize the sale at retail and serving of alcoholic liquor at a counter or bar and at tables, provided such operation is carried on in conjunction with a restaurant operation serving a menu offering complete meals. The bar service or service at tables where a full menu is not available shall take place in a separate room from the full menu restaurant operation.

(B) It shall be unlawful for any person to sell or offer for sale alcoholic liquor in conjunction with a Class O liquor license between one o'clock (1:00) A.M. and seven o'clock (7:00) A.M., except on Saturdays and Sundays when it shall be unlawful for anyone to sell or offer for sale alcoholic liquor under a Class O liquor license between the hours of two o'clock (2:00) A.M. and seven o'clock (7:00) A.M. The Commissioner may extend the hours for lawful sale and service of alcoholic liquor on special occasions such as New Year's Eve.

- (C) Live music shall be permitted. Such music may be provided by a band, musical group or an individual playing an instrument. No person providing such music shall be under the age of eighteen (18). Such music shall be for the dancing or listening pleasure of patrons only.
- (D) The number of Class O licenses shall be one.
- (E) The annual fee for a Class O license shall be two thousand five hundred dollars (\$2,500.00). (Ord. 0-21-15, 6-15-2015)

3-3-7-16: CLASS P LICENSE:

- (A) A Class P license shall authorize the sale at retail of alcoholic liquor for consumption on the premises and the sale at retail of beer and wine in original package but not for consumption on the premises of sale, provided such sale and serving is accessory to the main purpose of the sale of food on a carryout basis.
- (B) It shall be unlawful for any person to sell or offer for sale at retail in the City between one o'clock (1:00) A.M. and eight o'clock (8:00) A.M. The Commissioner may extend the hours for lawful sale and service of alcoholic liquor on special occasions such as New Year's Eve.
- (C) The number of Class P licenses shall be one.
- (D) The annual fee for a Class P license shall be two thousand five hundred dollars (\$2,500.00). (Ord. 0-12-17, 7-17-2017)

3-3-7-17: PAYMENT OF FEES, EXPIRATION DATE:

- (A) All liquor license fees shall be paid to the City Clerk at the time of application. If the license is denied, such application fee shall be returned. Said license fees shall be deposited in the General Fund of the City. A separate fifty dollar (\$50.00) nonrefundable license application fee for each person to be investigated under section 3-3-17 of this chapter plus reasonable costs shall be tendered to the City Clerk with each application submitted for license. Such additional costs shall include, but are not limited to, fingerprinting fees for each applicant and/or member stockholder, and as such fees may be increased from time to time by the Illinois State Police and the Federal Bureau of Investigation (FBI) and their successors and assigns.
- (B) All licenses shall expire on June 30 of each year. (Ord. 0-39-94, 9-19-1994; amd. Ord. 0-14-05, 6-20-2005; Ord. 0-26-13, 10-7-2013; Ord. 0-34-14, 11-3-2014; Ord. 0-21-15, 6-15-2015; Ord. 0-12-17, 7-17-2017)

3-3-8: CONDITIONS AND RESTRICTIONS OF LICENSE:

- (A) Location:



Class License	License Number	Business Name	Street #	Street Name	Amount
A					
	A-1	Brookhaven Marketplace	7516	Cass Avenue, Suite 30	\$1,500.00
	A-10	Walgreens #06176	8300	Lemont Road	\$1,500.00
	A-11	Darien Tobacco Wine & Liquor	7516	Cass Avenue, #5A	\$1,500.00
	A-3	Jewel Food Store #0123	7335	Cass Avenue	\$1,500.00
	A-4	CVS Pharmacy #8501	8325	Lemont Road	\$1,500.00
	A-5	Osco Drug Store #0123	7329-7335	Cass Avenue	\$1,500.00
	A-6	Aldi, Inc #80	2251	75th Street	\$1,500.00
	A-7	Darien Liquor	8125	Cass Avenue	\$1,500.00
	A-8	Walmart #2215	2189	75th Street	\$1,500.00
	A-9	Walgreens #09033	7516	Cass Avenue	\$1,500.00
B					
	B-1	Alpine Banquets, Inc.	8230	Cass Avenue	\$2,000.00
C					
	C-1	Carriage Way West	8700	Carriage Green Drive	\$2,000.00
D					
	D-1	Tai San Chef	2813	83rd Street	\$2,000.00
	D-2	Patio Restaurant of Darien, Inc.	7440	Kingery Highway	\$2,000.00
	D-3	Aodake	2129	75th Street	\$2,000.00
	D-4	TGI Friday's Inc.	2201	75th Street	\$2,000.00
	D-5	Al Chile Mexican Grill, Inc.	8123	Cass Avenue	\$2,000.00
	D-6	Mi Hacienda	2601	75th Street	\$2,000.00
	D-7	Old Vilnius Café	2601	75th Street, Unit B	\$2,000.00
	D-8	Chiba Japanese Restaurant	7533	Cass Ave	\$2,000.00
	D-9	Dotty's	7516	Cass Avenue, #24	\$2,000.00

Class License	License Number	Business Name	Street #	Street Name	Amount
E					
	E-1	Darien Pantry	737	Plainfield Road	\$1,500.00
	E-2	Speedway #5344	8301	Lemont Road	\$1,500.00
	E-5	Circle K #4706713	8975	Lemont Road	\$1,500.00
	E-6	Speedway #7765	7502	Cass Ave	\$1,500.00
	E-7	Speedway #1425	10250	Lemont Road	\$1,500.00
F					
	F-1	Chuck E. Cheese	7409	Cass Avenue	\$1,500.00
G					
	G-1	Dry Dock	1125	North Frontage Road	\$2,000.00
H					
	H-1	Home Run Inn Corp.	7521	Lemont Road	\$2,500.00
	H-3	Café Smilga	2819	83rd Street	\$2,500.00
I					
	I-1	Q Bar	8109-8115	Cass Avenue	\$2,500.00
K					
	K-3	Buona	7417	Cass Avenue	\$1,500.00
	K-4	Brooster's	1010	Plainfield Road	\$1,500.00
	K-5	Stella's Place	2415	75th Street, Unit C2	\$1,500.00
M					
	M-1	VFW	801	Plainfield Road	\$1,000.00
N					
	N-1	Miskatonic Brewing Company	1000	N. Frontage Rd, Unit C	\$2,000.00
O					
	O-1	Chuck's Southern Comforts Café and Banquets, Inc.	8025	Cass Avenue	\$2,500.00
P					
	P-1	Zazzo's Pizza and Catering	7360	Route 83	\$2,500.00

Class License	License Number	Business Name	Street #	Street Name	Amount
Q	Q-1	Carmelite Gift Shop	8501	Bailey Rd	\$1,500.00



CITY OF DARIEN

DU PAGE COUNTY, ILLINOIS

ORDINANCE NO. _____

**AN ORDINANCE AMENDING SECTION 3-3-7-1(C), CLASS A LICENSE
AND SECTION 3-3-7-5(C) CLASS E LICENSE
OF THE DARIEN CITY CODE**

ADOPTED BY THE

MAYOR AND CITY COUNCIL

OF THE

CITY OF DARIEN

THIS 3rd DAY OF AUGUST, 2020

**Published in pamphlet form by authority of
the Mayor and City Council of the City of
Darien, DuPage County, Illinois, and this
___ day of August, 2020.**

ORDINANCE NO. _____

**AN ORDINANCE AMENDING SECTION 3-3-7-1(C), CLASS A LICENSE
AND SECTION 3-3-7-5(C) CLASS E LICENSE
OF THE DARIEN CITY CODE**

**NOW, THEREFORE, BE IT ORDAINED BY THE CITY COUNCIL OF THE CITY
OF DARIEN, DU PAGE COUNTY, ILLINOIS, IN THE EXERCISE OF ITS HOME RULE
POWERS, as follows:**

SECTION 1: Section 3-3-7-1(C) “Class A License”, as amended is hereby amended to increase the number of Class A licenses from ten (10) to eleven (11), to read as follows:

3-3-7-1: CLASS A LICENSE:

(C) The number of Class A licenses shall be eleven (11).

SECTION 2: Section 3-3-7-5(C) “Class E License”, as amended is hereby amended to decrease the number of Class E licenses from five (5) to four (4), to read as follows:

3-3-7-5: CLASS E LICENSE:

(C) The number of Class E licenses shall be four (4).

SECTION 3: Home Rule. This ordinance and each of its terms shall be the effective legislative act of a home rule municipality without regard to whether such ordinance should (a) contain terms contrary to the provisions of current or subsequent non-preemptive state law, or (b) legislate in a manner or regarding a matter not delegated to municipalities by state law. It is the intent of the corporate authorities of the City of Darien that to the extent of the terms of this ordinance should be inconsistent with any non-preemptive state law, that this ordinance shall supersede state law in that regard within its jurisdiction.

SECTION 4: Effective Date. This Ordinance shall be in full force and effect from and after its passage and approval as provided by law.

ORDINANCE NO. _____

PASSED BY THE CITY COUNCIL OF THE CITY OF DARIEN, DU PAGE COUNTY, ILLINOIS, this 3rd day of August, 2020.

AYES: _____

NAYS: _____

ABSENT: _____

APPROVED BY THE MAYOR OF THE CITY OF DARIEN, DU PAGE COUNTY, ILLINOIS, this 3rd day of August, 2020.

JOSEPH A. MARCHESE, MAYOR

ATTEST:

JOANNE E. RAGONA, CITY CLERK

APPROVED AS TO FORM:

CITY ATTORNEY

AGENDA MEMO
City Council
August 3, 2020

ISSUE STATEMENT

Approval of a [resolution](#) accepting a Plat of Easement for a Landscape Feature, (Northwest Corner of Cass Avenue and Plainfield Road at 7532 Cass Avenue, PIN# 09-28-402-025.

AND

Approval of a [resolution](#) for a Landscape Feature Agreement and a dedicated easement at the northwest corner at 7532 Cass Avenue, PIN# 09-28-402-025.

AND

Approval of a [resolution](#) to reimburse 7532 Cass Ave LLC in an amount not to exceed \$22,750 for the construction of the landscape feature located at 7532 Cass Ave.

BACKGROUND/HISTORY

As part of an enhancement to the Center of Town, City Staff was directed to render drawings for a landscape feature at the northwest corner of Cass Avenue and Plainfield Road, see [Attachment A](#), with a common address of 7532 Cass Avenue and as per the legal description attached as [Exhibit 1](#). The landscape enhancement includes a design with a pond-less water feature. The water feature would run 365 days a year. The City Council discussed the enhancement along with 3 conceptual options at the July 20, 2020 City Council Meeting. City Council recommended through a Motion to move forward with Option No. 3 as presented, with a 5-2 vote.

The landscape enhancement would further incorporate two signs for the business. The signs will meet the City code and will not require variations. All sign costs will be the responsibility of 7532 Cass Avenue LLC.

Below is a summary of the Easement Agreement and the Landscape Feature:

The Easement Agreement encapsulates the following:

- The Easement Agreement labeled as [Exhibit 2](#), is an agreement between the City and the property owner, 7532 Cass Avenue LLC. The Plat of Easement, included in the attachment, will be recorded with the County of DuPage upon approval of the Easement Agreement.
- Creates an easement area which allows the City to construct and maintain hardscaping and landscaping and authorizes recordation of the corresponding Plat of Easement labeled as [Exhibit 3](#).
- The agreement gives the City a right to vacate the easement in 10 years.
- City will be responsible for all maintenance within the dedicated easement-including the landscape water feature and general landscaping. The costs for these items will be shared at a 50/50 cost with 7532 Cass Ave, LLC.
- There shall be no cost to the City for energy.
- The City will bear the cost of the water expense for the water feature. It is estimated that between 1,000-5,000 gallons of water may be utilized pending conditions such as, hot

weather-evaporation, ice formation in winter and wind conditions. Cost is estimated at approximately \$10 to \$50 annually

The project will be constructed through the 7532 Cass Ave LLC, as per the schedule of costs labeled as [Attachment B](#). The total cost of the project is estimated at \$45,500 and the cost to be shared by the City and 7532 Cass Ave LLC in an amount not to exceed each at \$22,750. The City of Darien Municipal Services Department will coordinate task and oversight with the owners' representatives. The City will reimburse the owner upon receipt of invoices and will be based upon review of actual quantities/lump sum costs, lien waivers and certified payrolls.

Funds for the proposed project have not been allocated for this year's budget. Funds for the project may be charged to the following Capital Account:

ACCOUNT NUMBER	ACCOUNT DESCRIPTION	FY 20-21 BUDGET	PROPOSED EXPENDITURE
25-35-0000	7532 Cass Ave Landscape Feature-City Share	-0-	\$ 22,750

STAFF RECOMMENDATION

Approval of a resolution accepting a Plat of Easement for a Landscape Feature, (Northwest Corner of Cass Avenue and Plainfield Road at 7532 Cass Avenue, PIN# 09-28-402-025.

AND

Approval of a resolution for a Landscape Feature Agreement within a dedicated easement at the northwest corner at 7532 Cass Avenue, PIN# 09-28-402-025.

AND

Approval of a resolution to reimburse 7532 Cass Ave LLC in an amount not to exceed \$22,750 for the construction of the landscape feature located at 7532 Cass Ave.

COMMITTEE RECOMMENDATION

Not Applicable-Final Document for City Council Consideration

ALTERNATE CONSIDERATION

As directed by the City Council.

DECISION MODE

This item will be placed on the August 3, 2020 City Council agenda for formal consideration.

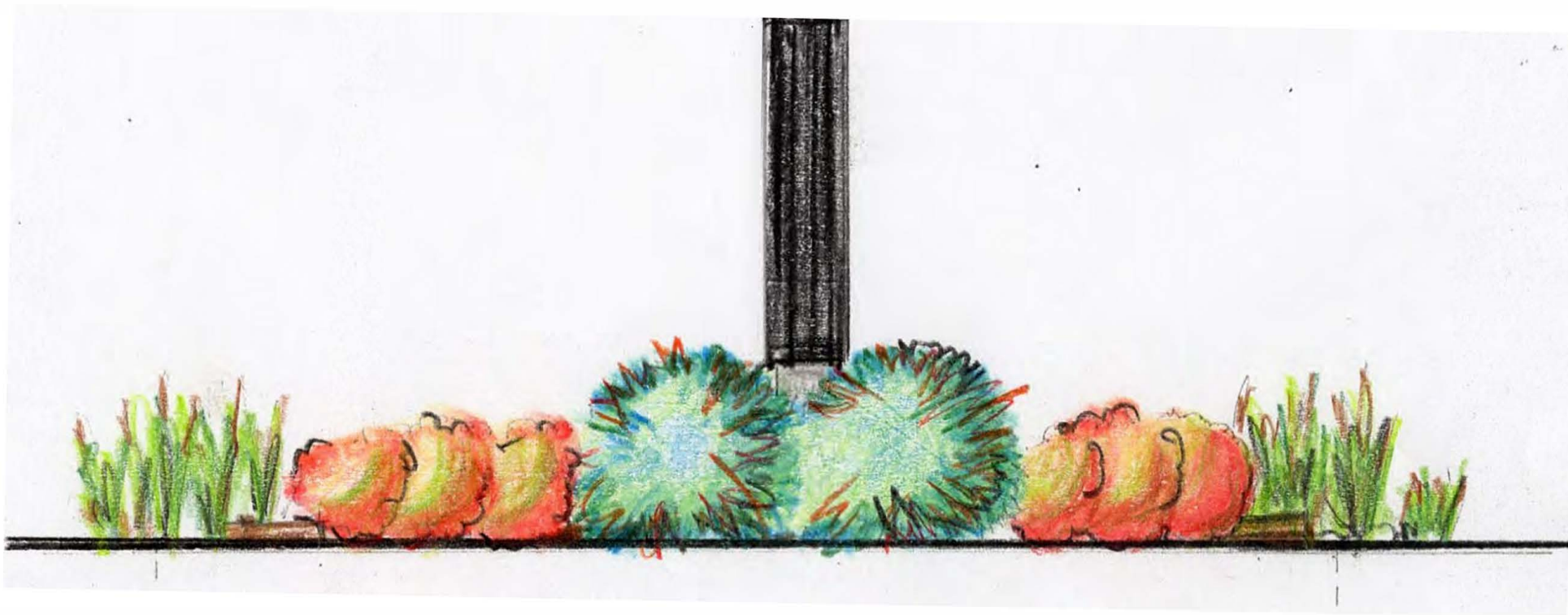

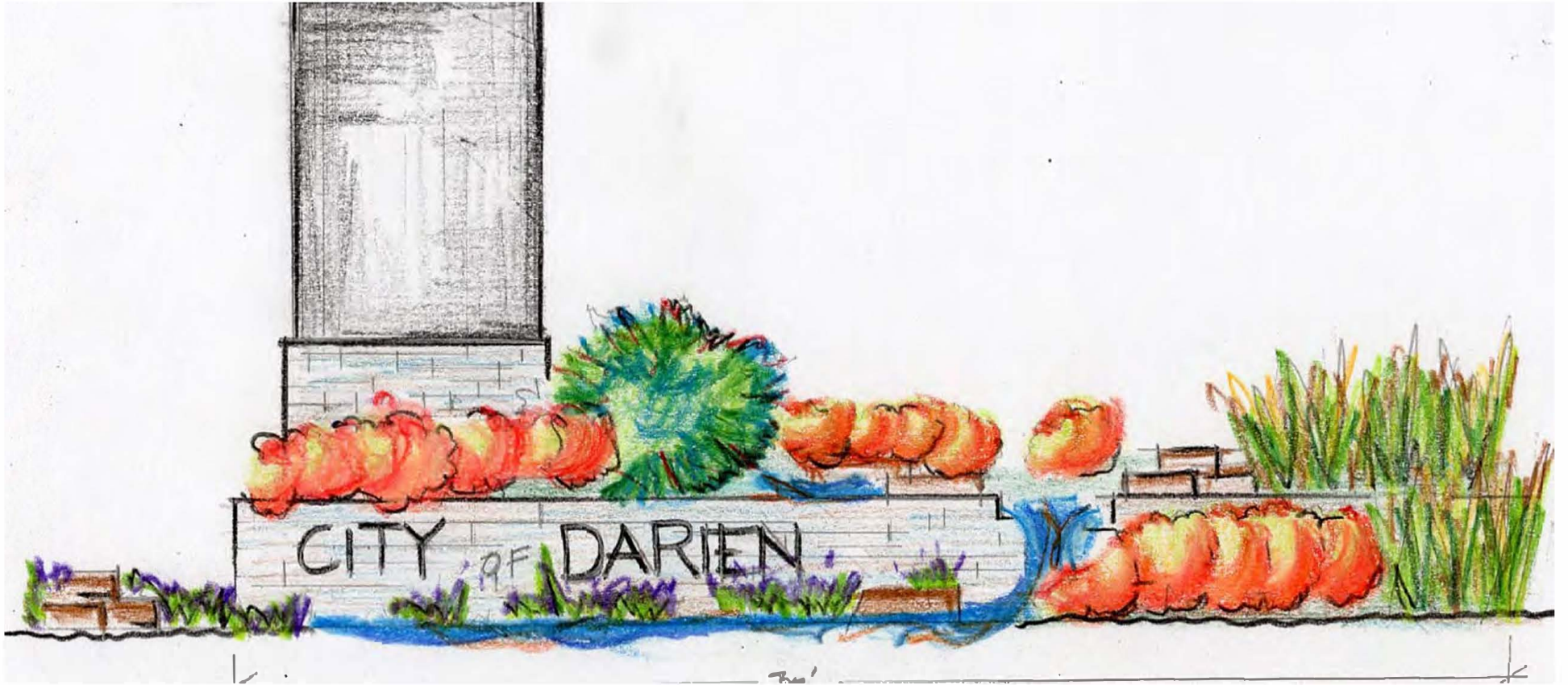

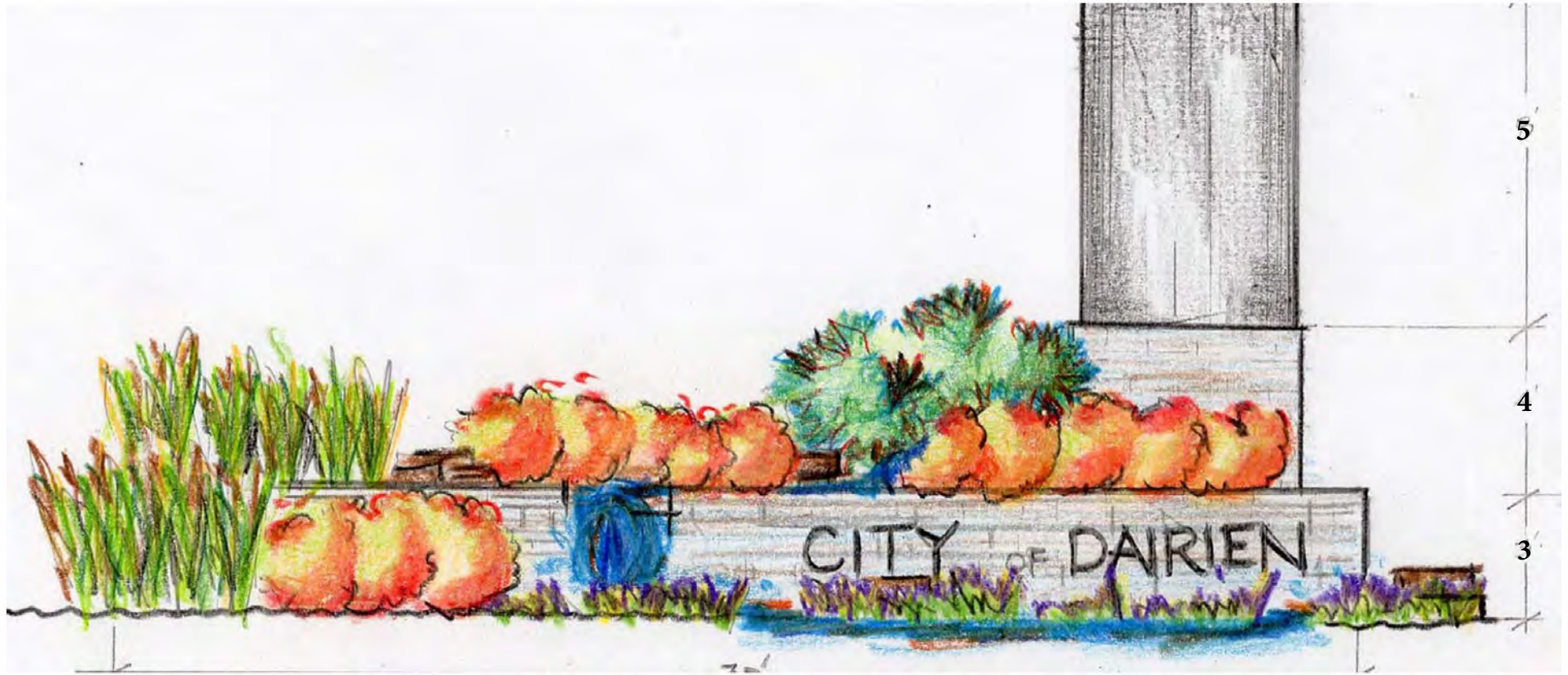

5

4

3

CITY OF DARIEN

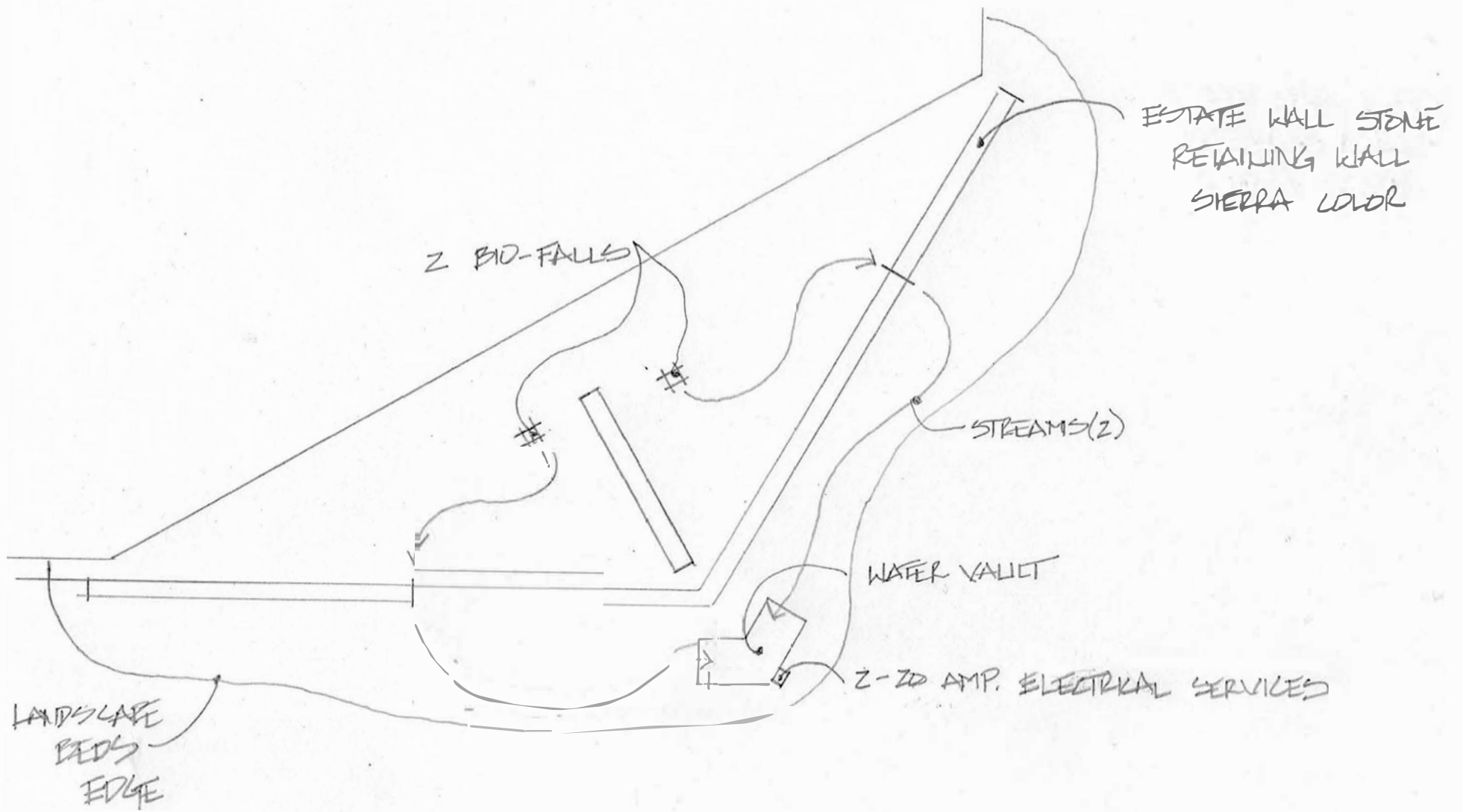

OPTION 4

#3

SCALE: 1/8" = 1'-0"

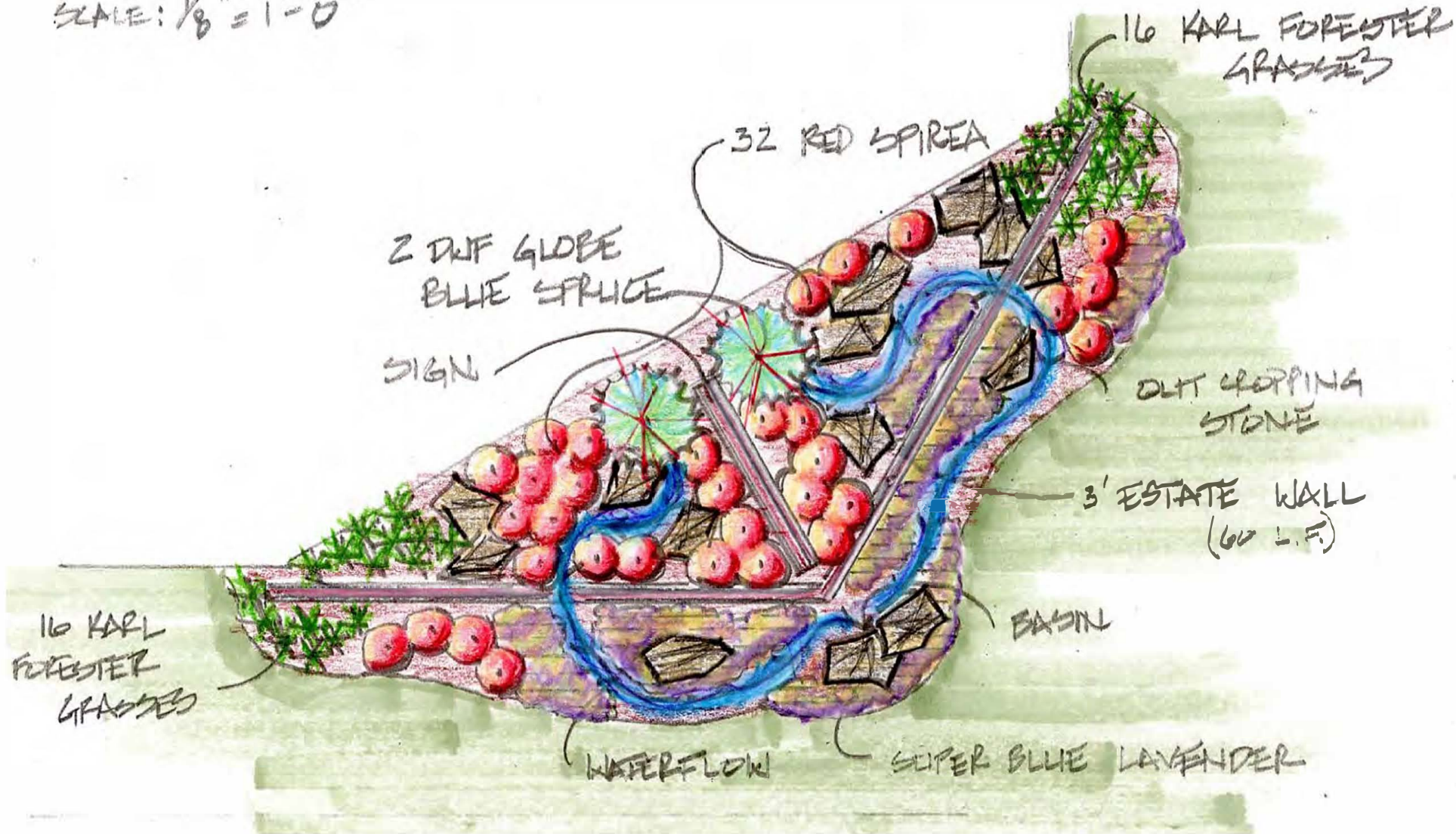

EXHIBIT 1**Legal Description**

Said property is legally described as follows:

PROPOSED LANDSCAPE EASEMENT DESCRIPTION:

THAT PART OF LOT 302 IN BROOKHAVEN MANOR SUBDIVISION, BEING A SUBDIVISION IN SECTIONS 27 AND 28, TOWNSHIP 28 NORTH, RANGE 11 EAST OF THE THIRD PRINCIPAL MERIDIAN, DESCRIBED AS FOLLOWS; BEGINNING AT THE INTERSECTION OF THE NORTHERLY LINE OF PLAINFIELD ROAD AND THE WESTERLY LINE OF CASS AVENUE; THENCE SOUTH 63 DEGREES 43 MINUTES 44 SECONDS WEST ALONG SAID NORTHERLY LINE, 35.00 FEET; THENCE NORTH 31 DEGREES 07 MINUTES 20 SECONDS EAST, 58.97 FEET TO SAID WESTERLY LINE OF CASS AVENUE; THENCE SOUTH 01 DEGREES 29 MINUTES 05 SECONDS EAST ALONG SAID WESTERLY LINE, 35.00 FEET TO THE POINT OF BEGINNING, ALL IN DUPAGE COUNTY, ILLINOIS.

PARENT PARCEL DESCRIPTION:

THAT PART OF LOT 302 DESCRIBED AS FOLLOWS; BEGINNING AT THE INTERSECTION OF THE NORTHERLY LINE OF PLAINFIELD ROAD AND THE WESTERLY LINE OF CASS AVENUE; THENCE WESTERLY ALONG THE NORTHERLY LINE OF PLAINFIELD ROAD, 155 FEET; THENCE NORTHERLY AND PARALLEL WITH CASS AVENUE, 210.00 FEET; THENCE EASTERLY ON A LINE PERPENDICULAR TO CASS AVENUE, 145 FEET TO A POINT ON THE WESTERLY LINE OF CASS AVENUE; THENCE SOUTHERLY ALONG THE WESTERLY LINE OF CASS AVENUE 145 FEET TO THE PLACE OF BEGINNING, IN BROOKHAVEN MANOR, A SUBDIVISION IN SECTIONS 27 AND 28, TOWNSHIP 38 NORTH, RANGE 11 EAST OF THE THIRD PRINCIPAL MERIDIAN, ACCORDING TO THE PLAT THEREOF RECORDED DECEMBER 18, 1956 AS DOCUMENT 827287, IN DUPAGE COUNTY, ILLINOIS.

PIN: 09-28-402-025

The property is located at 7532 South Cass Avenue, Darien, Illinois 60561.

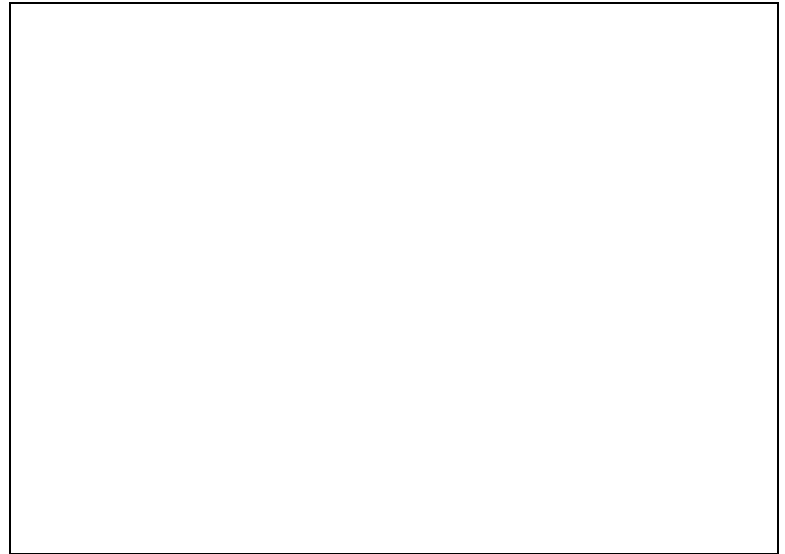

EASEMENT AGREEMENT

THIS EASEMENT AGREEMENT (“Agreement”) is dated the ____ day of _____, 2020, by and between 7532 Cass Avenue L.L.C. (“Owner”) and the City of Darien, a municipal corporation with offices at 1702 Plainfield Road, Darien, Illinois 60561 (“City”).

RECITALS:

- A. Owner is the owner of certain property described on [Exhibit 1](#) attached hereto and made a part hereof (the “Subject Property”).
- B. Owner is in the process of developing the Subject Property for commercial use.
- C. The Subject Property fronts both Cass Avenue and Plainfield Road within the City. The City and Owner have been in negotiations in order to collaborate on the installation and maintenance of decorative landscaping features on the “Easement Area” defined below.
- D. In connection with the Agreement, the parties have agreed that Owner will grant the City temporary and permanent easements as set forth hereinbelow.

Accordingly, it is hereby agreed by and between Owner and City as follows:

Section 1. Grant of Easement. Owner hereby grants the City an easement to the “Easement Area” as shown on the Plat attached to this Agreement as [Exhibit 2](#) for purposes of maintaining decorative landscaping features within the Easement Area. An illustration of the landscape features is shown on [Exhibit 3](#).

Section 2. Construction; Maintenance; Cost Sharing

- A. Owner shall be responsible for the construction of the landscape features. The landscape feature plans shall be subject to the City's review and approval. The City will reimburse Owner for 50% of the landscape feature construction cost, up to a maximum City reimbursement obligation of \$27,500.00.
- B. The City shall be solely responsible for the maintenance of the Easement Area. The City and Owner will share the maintenance costs on a 50-50 basis.
- C. The City may assign maintenance responsibilities to a third-party contractor.
- D. Owner shall be responsible for energy costs in connection with the landscaping features. The City will be responsible for all costs connected with providing water for the landscape features.

Section 3. Vacation of Easement

The City reserves the right to vacate the Easement granted by this Agreement after 10 years from the date of initial landscaping installation.

Section 4. Recordation

This Agreement shall be recorded in the Office of the DuPage County Recorder of Deeds at the City's expense.

OWNER:

7532 Cass Avenue LLC

By: _____

Attest: _____

Date: _____

CITY:

CITY OF DARIEN

By: _____

Attest: _____



EXHIBIT 1

Legal Description

Said property is legally described as follows:

PROPOSED LANDSCAPE EASEMENT DESCRIPTION:

THAT PART OF LOT 302 IN BROOKHAVEN MANOR SUBDIVISION, BEING A SUBDIVISION IN SECTIONS 27 AND 28, TOWNSHIP 28 NORTH, RANGE 11 EAST OF THE THIRD PRINCIPAL MERIDIAN, DESCRIBED AS FOLLOWS; BEGINNING AT THE INTERSECTION OF THE NORTHERLY LINE OF PLAINFIELD ROAD AND THE WESTERLY LINE OF CASS AVENUE; THENCE SOUTH 63 DEGREES 43 MINUTES 44 SECONDS WEST ALONG SAID NORTHERLY LINE, 35.00 FEET; THENCE NORTH 31 DEGREES 07 MINUTES 20 SECONDS EAST, 58.97 FEET TO SAID WESTERLY LINE OF CASS AVENUE; THENCE SOUTH 01 DEGREES 29 MINUTES 05 SECONDS EAST ALONG SAID WESTERLY LINE, 35.00 FEET TO THE POINT OF BEGINNING, ALL IN DUPAGE COUNTY, ILLINOIS.

PARENT PARCEL DESCRIPTION:

THAT PART OF LOT 302 DESCRIBED AS FOLLOWS; BEGINNING AT THE INTERSECTION OF THE NORTHERLY LINE OF PLAINFIELD ROAD AND THE WESTERLY LINE OF CASS AVENUE; THENCE WESTERLY ALONG THE NORTHERLY LINE OF PLAINFIELD ROAD, 155 FEET; THENCE NORTHERLY AND PARALLEL WITH CASS AVENUE, 210.00 FEET; THENCE EASTERLY ON A LINE PERPENDICULAR TO CASS AVENUE, 145 FEET TO A POINT ON THE WESTERLY LINE OF CASS AVENUE; THENCE SOUTHERLY ALONG THE WESTERLY LINE OF CASS AVENUE 145 FEET TO THE PLACE OF BEGINNING, IN BROOKHAVEN MANOR, A SUBDIVISION IN SECTIONS 27 AND 28, TOWNSHIP 28 NORTH, RANGE 11 EAST OF THE THIRD PRINCIPAL MERIDIAN, ACCORDING TO THE PLAT THEREOF RECORDED DECEMBER 18, 1956 AS DOCUMENT 827287, IN DUPAGE COUNTY, ILLINOIS.

PIN: 09-28-402-025

The property is located at 7532 South Cass Avenue, Darien, Illinois 60561.

SUBMITTED BY AND RETURN TO:
CITY OF DARIEN
1702 PLAINFIELD ROAD
DARIEN, IL 60561

PLAT OF EASEMENT

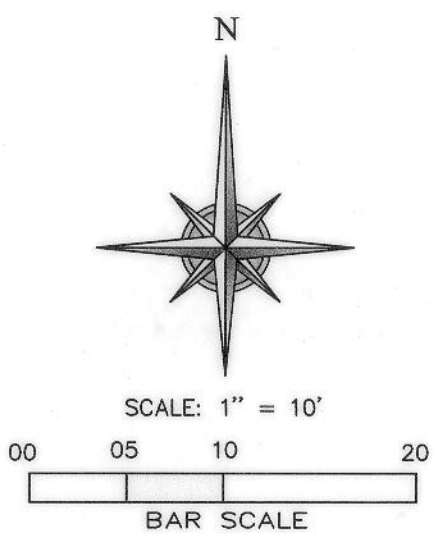
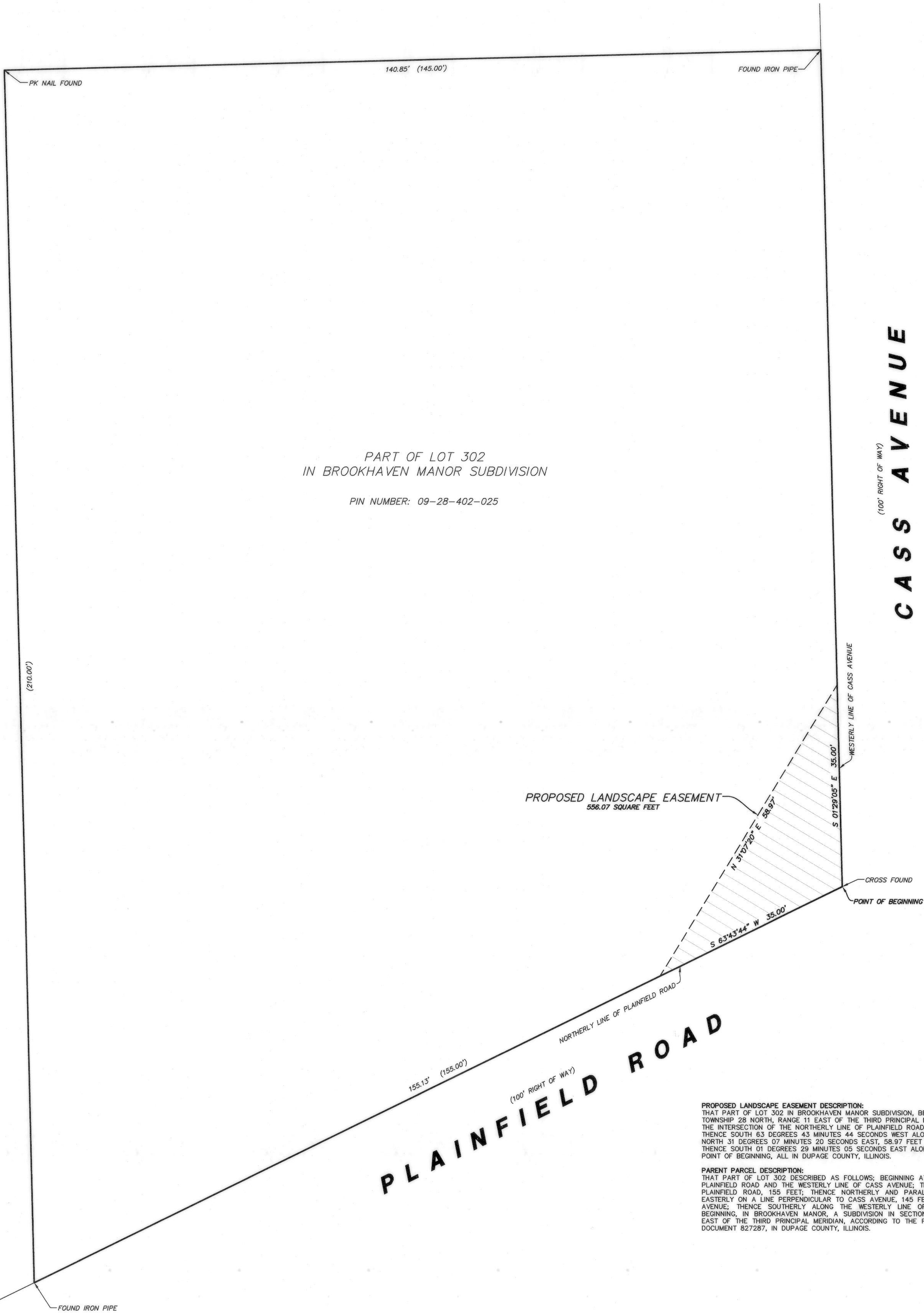

PART OF LOT 302
IN BROOKHAVEN MANOR SUBDIVISION
PIN NUMBER: 09-28-402-025

PROPOSED LANDSCAPE EASEMENT DESCRIPTION:
THAT PART OF LOT 302 IN BROOKHAVEN MANOR SUBDIVISION, BEING A SUBDIVISION IN SECTIONS 27 AND 28, TOWNSHIP 28 NORTH, RANGE 11 EAST OF THE THIRD PRINCIPAL MERIDIAN, DESCRIBED AS FOLLOWS: BEGINNING AT THE INTERSECTION OF THE NORTHERLY LINE OF PLAINFIELD ROAD AND THE WESTERLY LINE OF CASS AVENUE; THENCE SOUTH 63 DEGREES 43 MINUTES 44 SECONDS WEST ALONG SAID NORTHERLY LINE, 35.00 FEET; THENCE NORTH 31 DEGREES 07 MINUTES 20 SECONDS EAST, 68.97 FEET TO SAID WESTERLY LINE OF CASS AVENUE; THENCE SOUTH 01 DEGREES 29 MINUTES 05 SECONDS EAST ALONG SAID WESTERLY LINE, 35.00 FEET TO THE POINT OF BEGINNING, ALL IN DUPAGE COUNTY, ILLINOIS.

PARENT PARCEL DESCRIPTION:
THAT PART OF LOT 302, DESCRIBED AS FOLLOWS: BEGINNING AT THE INTERSECTION OF THE NORTHERLY LINE OF PLAINFIELD ROAD AND THE WESTERLY LINE OF CASS AVENUE; THENCE WESTERLY ALONG THE NORTHERLY LINE OF PLAINFIELD ROAD, 155 FEET; THENCE NORTHERLY AND PARALLEL WITH CASS AVENUE, 210.00 FEET; THENCE EASTERLY ON A LINE PERPENDICULAR TO CASS AVENUE, 145 FEET TO A POINT ON THE WESTERLY LINE OF CASS AVENUE; THENCE SOUTHERLY ALONG THE WESTERLY LINE OF CASS AVENUE 145 FEET TO THE PLACE OF BEGINNING, IN BROOKHAVEN MANOR, A SUBDIVISION IN SECTIONS 27 AND 28, TOWNSHIP 28 NORTH, RANGE 11 EAST OF THE THIRD PRINCIPAL MERIDIAN, ACCORDING TO THE PLAT THEREOF RECORDED DECEMBER 18, 1956 AS DOCUMENT 827287, IN DUPAGE COUNTY, ILLINOIS.

OWNER'S CERTIFICATE

STATE OF _____ SS
COUNTY OF _____

THIS IS TO CERTIFY THAT _____ IS THE HOLDER OF RECORD TITLE TO THE PROPERTY DESCRIBED HEREON, AND HAS CAUSED THE SAME TO BE SURVEYED AND PLATTED, AS SHOWN BY THIS PLAT FOR THE USES AND PURPOSES HEREIN SET FORTH AND THAT SAID OWNER HEREBY ACKNOWLEDGE AND ADOPTS THE SAME UNDER THE STYLE AND TITLE HEREON SHOWN.

DATED THIS _____ DAY OF _____ A.D. 20____

(NAME)

(TITLE)

(ADDRESS)

CITY COUNCIL CERTIFICATE

STATE OF ILLINOIS SS
COUNTY OF DUPAGE

APPROVED BY THE MAYOR AND CITY COUNCIL OF THE CITY OF DARIEN, DUPAGE COUNTY, ILLINOIS.

THIS _____ DAY OF _____, A.D. 20____

MAYOR

CLERK

DUPAGE COUNTY RECORDER

STATE OF ILLINOIS SS
COUNTY OF DUPAGE

THIS PLAT WAS FILED FOR RECORD IN THE RECORDER'S OFFICE OF DUPAGE COUNTY, ILLINOIS ON THE _____ DAY OF _____ A.D. 20____ AT _____ O'CLOCK _____ M. AS DOCUMENT NUMBER _____

DUPAGE COUNTY RECORDER

NOTARY'S CERTIFICATE

STATE OF ILLINOIS SS
COUNTY OF _____

I, _____, A NOTARY PUBLIC IN AND FOR SAID COUNTY, IN THE STATE AFORESAID, DO CERTIFY THAT _____ PERSONALLY KNOWN TO ME TO BE THE SAME PERSONS WHOSE NAMES ARE SUBSCRIBED TO THE FOREGOING INSTRUMENT AS SUCH OWNERS, APPEARED BEFORE ME THIS DAY IN PERSON AND ACKNOWLEDGED THAT THEY SIGNED AND DELIVERED THE ANNEXED PLAT AS THEIR OWN FREE AND VOLUNTARY ACT FOR THE USES AND PURPOSES THEREIN SET FORTH.

GIVEN UNDER MY HAND AND NOTARIAL SEAL THIS _____ DAY OF _____

NOTARY PUBLIC
MY COMMISSION EXPIRES: _____

PERMISSION TO RECORD CERTIFICATE

STATE OF ILLINOIS SS
COUNTY OF COOK

I, FRANJO I. MATIĆ, ILLINOIS PROFESSIONAL LAND SURVEYOR #035-003556, HEREBY AUTHORIZE AN AGENT OF THE CITY OF DARIEN AND/OR ITS DESIGNATED AGENTS TO RECORD THIS PLAT OF EASEMENT WITH THE OFFICE OF THE DUPAGE COUNTY RECORDER OF DEEDS.

GIVEN UNDER OUR HAND AND SEAL THIS 28TH DAY OF JULY, A.D. 2020, AT HOFFMAN ESTATES, ILLINOIS.

FRANJO I. MATIĆ - PLS #035-003556 EXPIRES 11/30/2020
ILLINOIS PROFESSIONAL DESIGN FIRM LICENSE NO. 184.007570-0015

SURVEYORS CERTIFICATE

STATE OF ILLINOIS SS
COUNTY OF COOK

I, FRANJO I. MATIĆ, ILLINOIS PROFESSIONAL LAND SURVEYOR #035-003556, HAVE SURVEYED AND PREPARED THE GRANT OF EASEMENT FOR THE PROPERTY DESCRIBED ABOVE AS SHOWN BY THE ANNEXED PLAT WHICH IS A CORRECT AND TRUE REPRESENTATION OF SAID SURVEY AND PLAT OF EASEMENT GRANT, ALL DISTANCES ARE SHOWN IN FEET AND DECIMAL PARTS THEREOF.

I FURTHER CERTIFY THAT ALL REGULATIONS ENACTED BY THE MAYOR AND CITY COUNCIL OF DARIEN RELATIVE TO PLATS AND SUBDIVISIONS HAVE BEEN COMPLIED WITH IN PREPARATION OF THIS PLAT. I FURTHER CERTIFY THAT THE LAND IS WITHIN THE CITY OF DARIEN (OR WITHIN ONE AND ONE HALF MILES OF THE CORPORATE LIMITS OF THE CITY OF DARIEN) WHICH HAS ADOPTED A CITY COMPREHENSIVE PLAN AND MAP AND IS EXERCISING THE SPECIAL POWERS AUTHORIZED BY DIVISION 12 OF ARTICLE 11 OF THE ILLINOIS MUNICIPAL CODE AS HERETOFORE AND HEREAFTER AMENDED.

GIVEN UNDER OUR HAND AND SEAL THIS 28TH DAY OF JULY, A.D. 2020, AT HOFFMAN ESTATES, ILLINOIS.

FRANJO I. MATIĆ - PLS #035-003556 EXPIRES 11/30/2020
ILLINOIS PROFESSIONAL DESIGN FIRM LICENSE NO. 184.007570-0015



AQUATIC \ CIVIL \ MECHANICAL \ ELECTRICAL \ PLUMBING \ TELECOMMUNICATION \ STRUCTURAL \ ACCESSIBILITY CONSULTING \ DESIGN & PROGRAM MANAGEMENT \ LAND SURVEY

EASE-1
PLAT OF EASEMENT
SHEET 1 OF 1

JOB: 20171965
DRAWN: KICM
CHECKED: M
DATE: 7/27/20

TO	DATE
CLIENT	7/27/20
CLIENT	7/28/20

CASS AVENUE AND PLAINFIELD ROAD
DARIEN, ILLINOIS



WT GROUP
Engineering with Precision, Pace and Passion.
2875 Pratum Avenue | Hoffman Estates, IL 60192
T: 224.293.6333 | F: 224.293.6444
wtegrouping.com
IL License No: 184.007570-0015 Expires: 04.30.2021
© COPYRIGHT 2020 THE WT GROUP, LLC

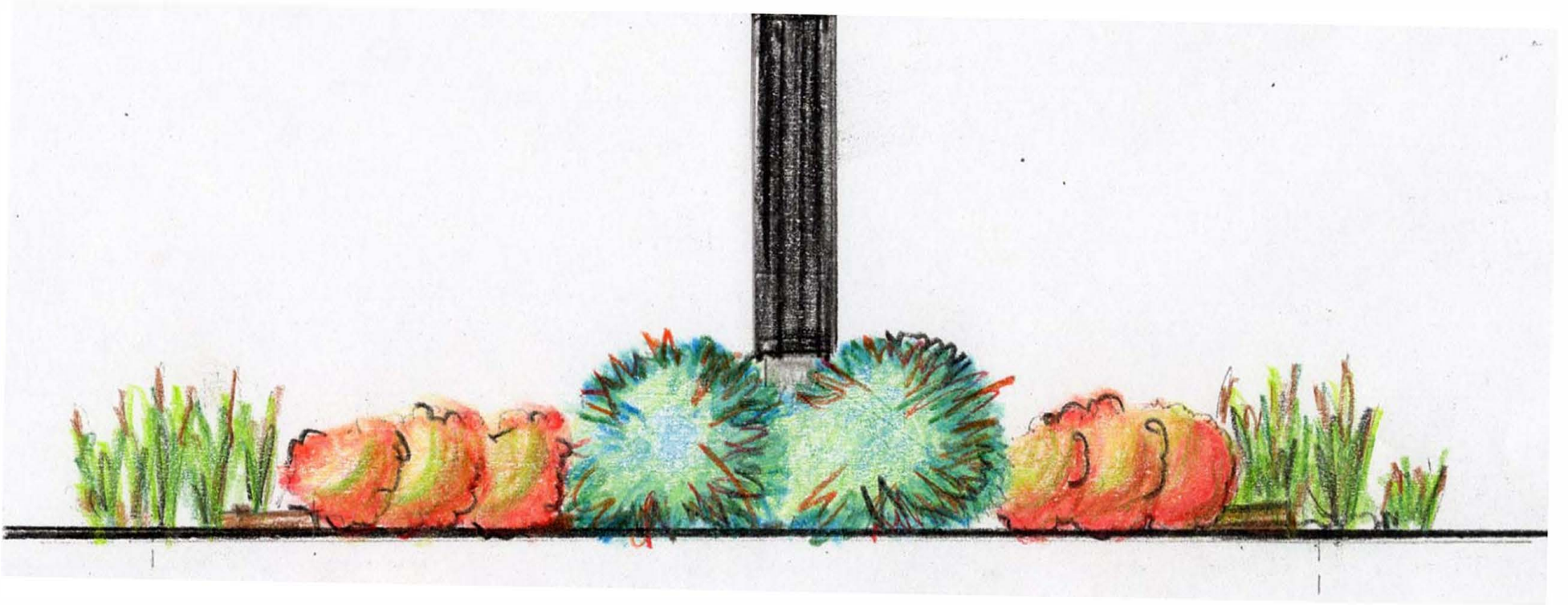

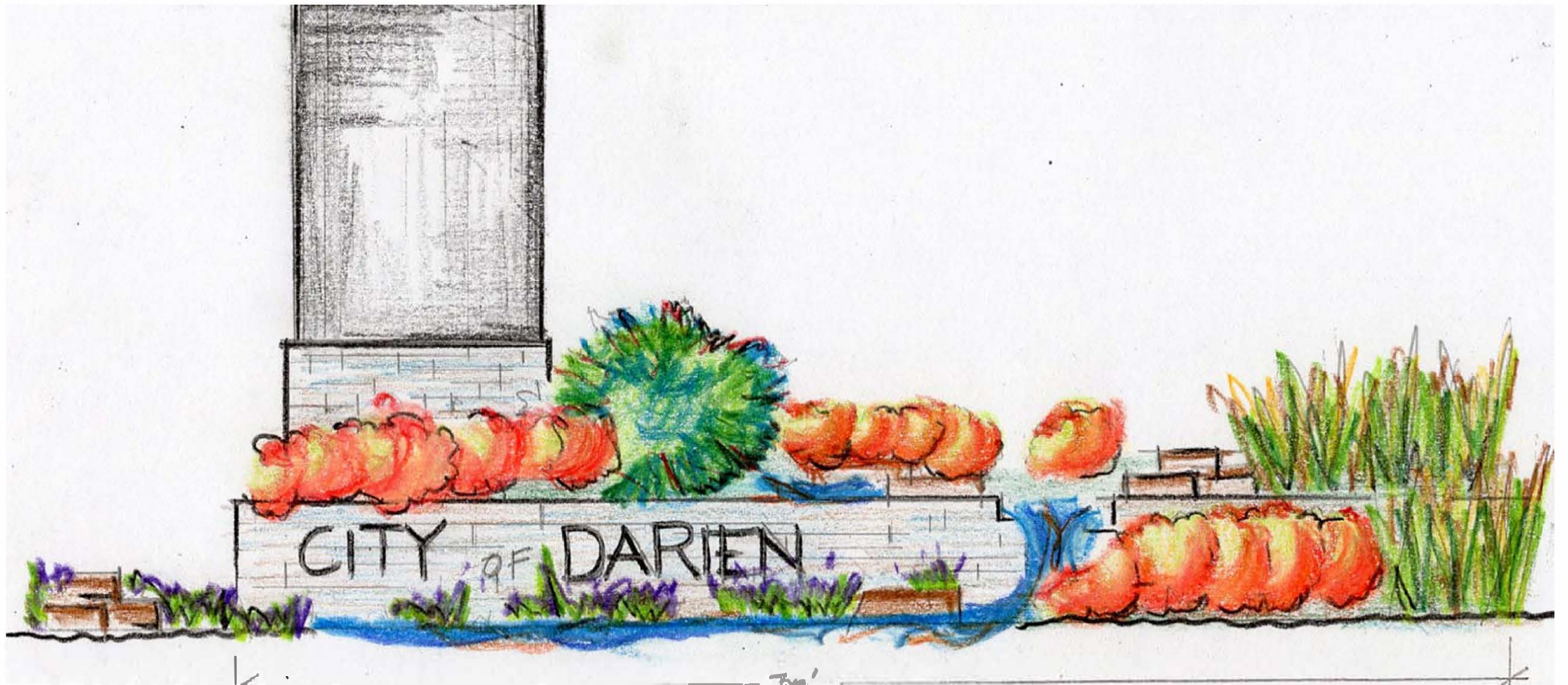

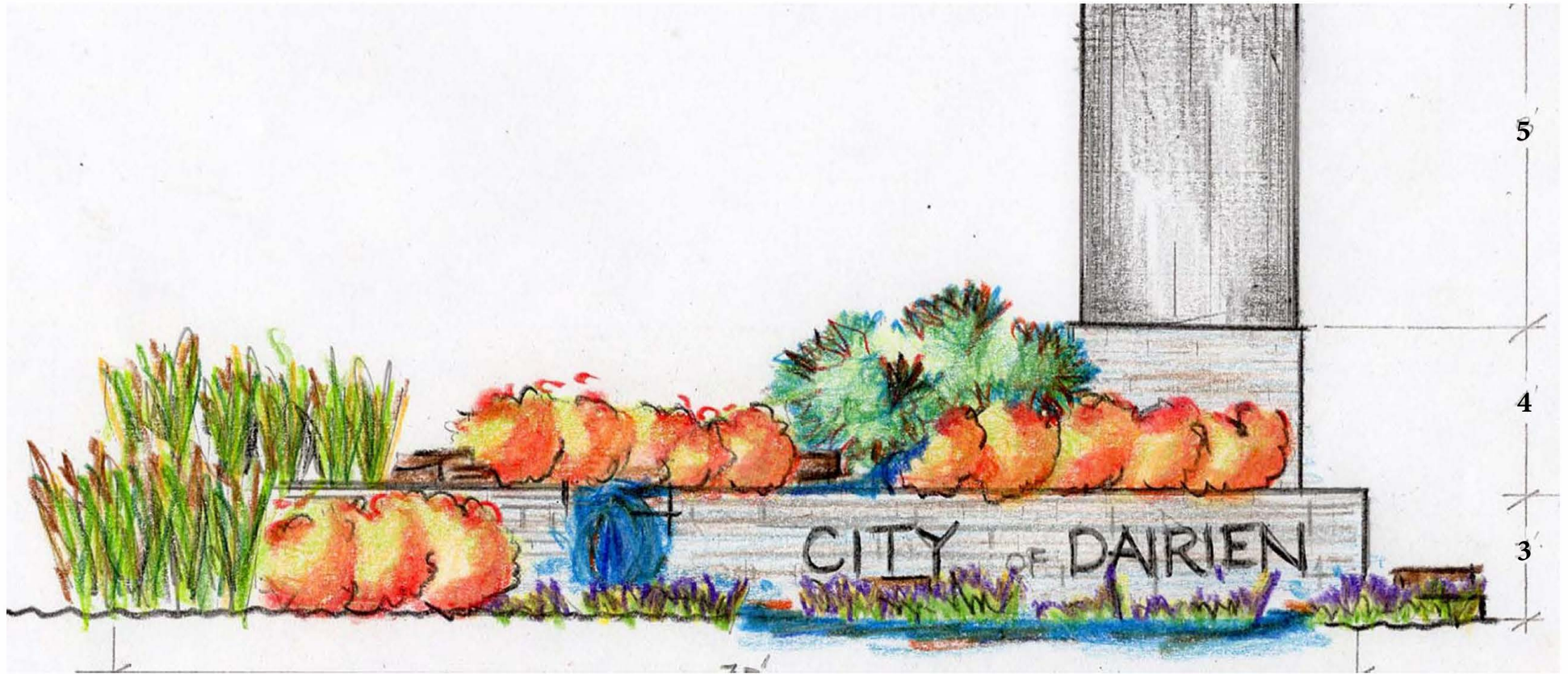

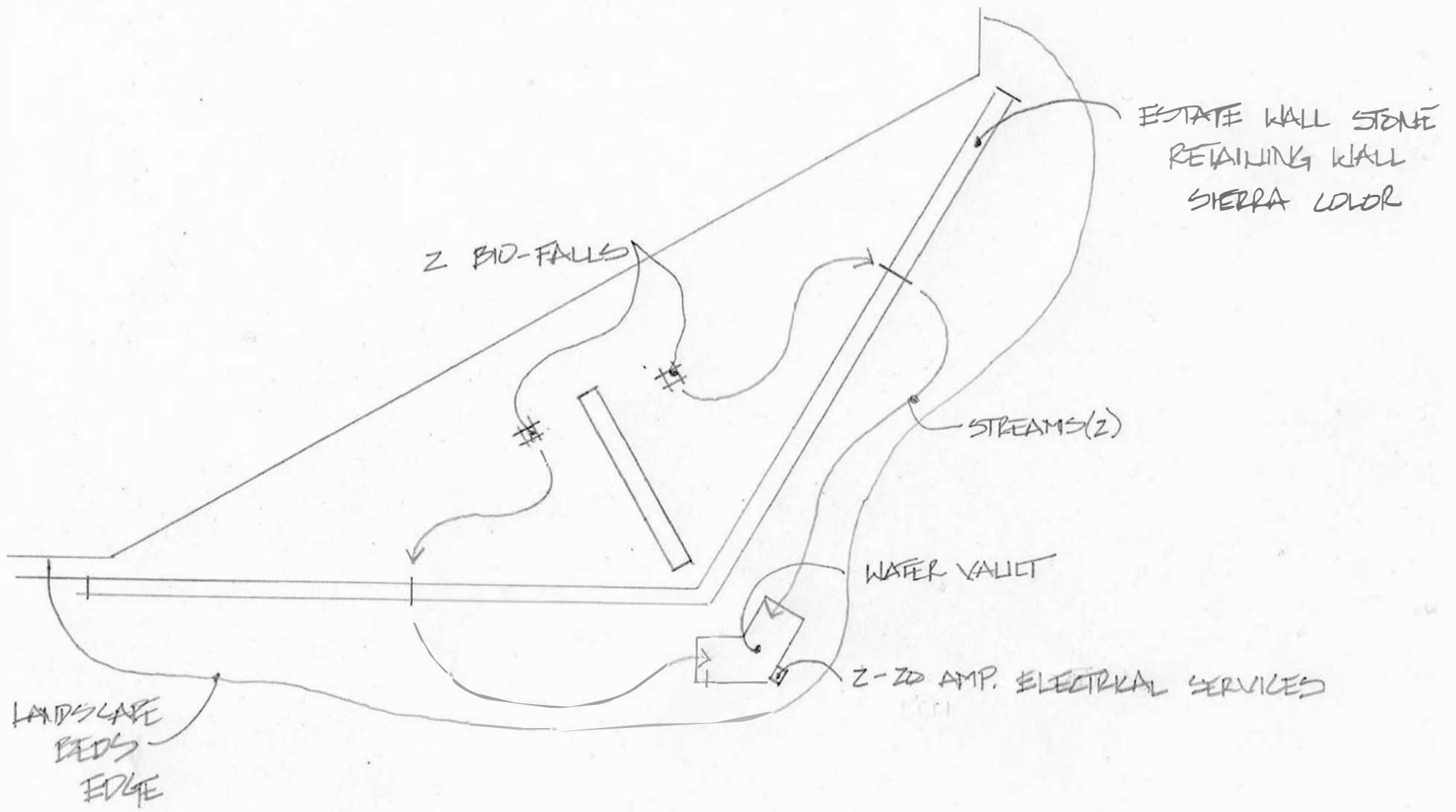

OPTION

#3

SCALE: $\frac{1}{8}'' = 1'-0''$

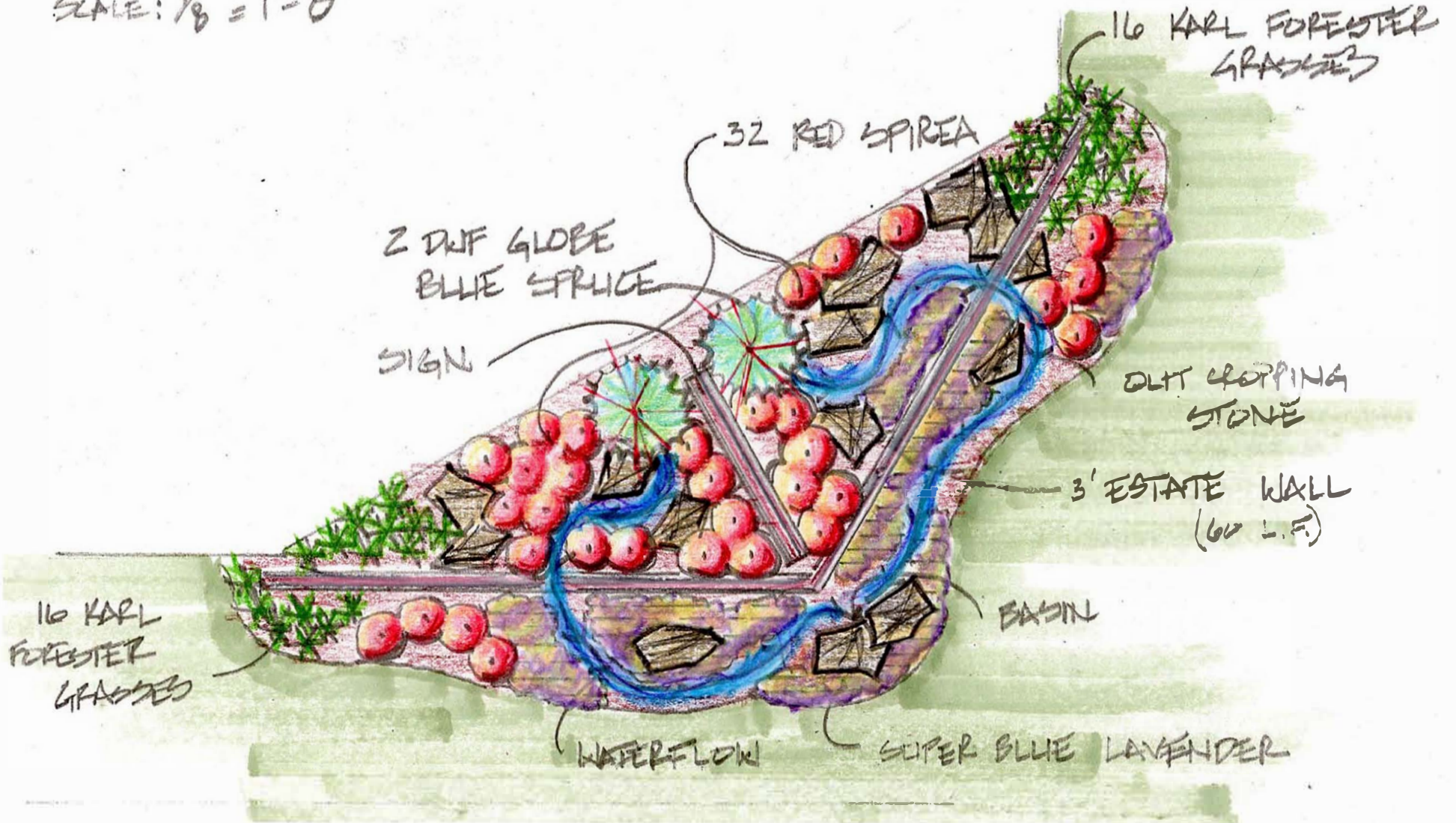

MEMO

PLAT OF EASEMENT

SUBMITTED BY AND RETURN TO:
CITY OF DARIEN
1702 PLAINFIELD ROAD
DARIEN, IL 60561

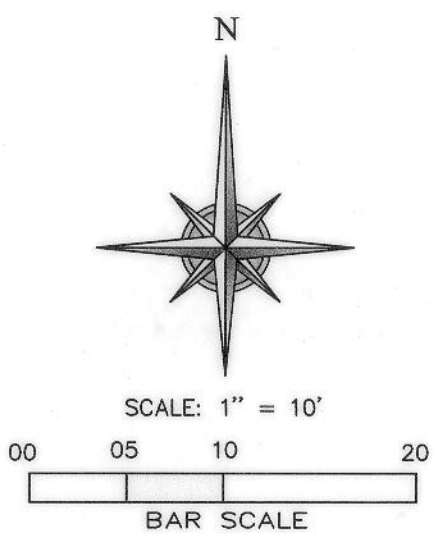
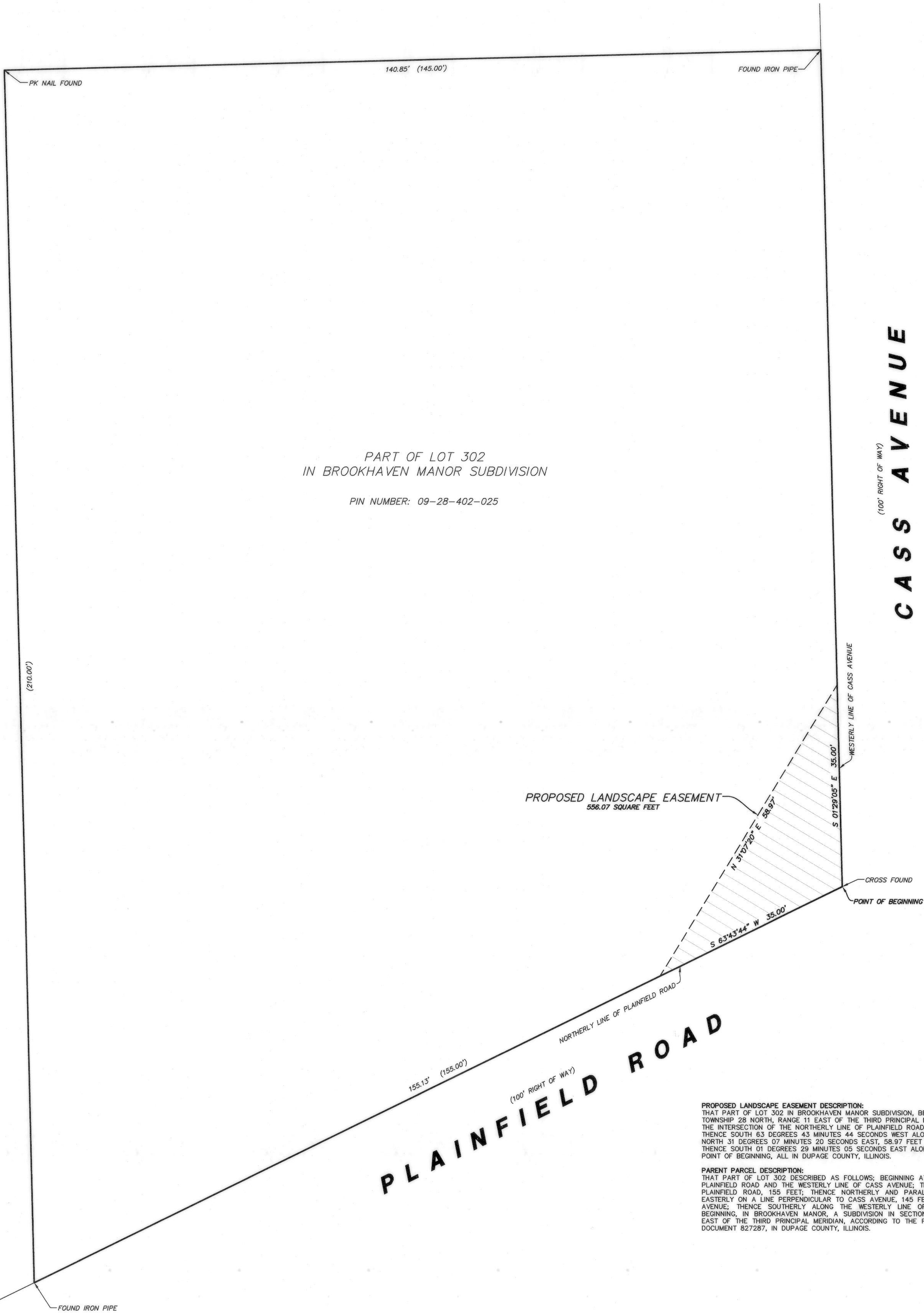

PART OF LOT 302
IN BROOKHAVEN MANOR SUBDIVISION
PIN NUMBER: 09-28-402-025

PROPOSED LANDSCAPE EASEMENT DESCRIPTION:
THAT PART OF LOT 302 IN BROOKHAVEN MANOR SUBDIVISION, BEING A SUBDIVISION IN SECTIONS 27 AND 28, TOWNSHIP 28 NORTH, RANGE 11 EAST OF THE THIRD PRINCIPAL MERIDIAN, DESCRIBED AS FOLLOWS: BEGINNING AT THE INTERSECTION OF THE NORTHERLY LINE OF PLAINFIELD ROAD AND THE WESTERLY LINE OF CASS AVENUE; THENCE SOUTH 63 DEGREES 43 MINUTES 44 SECONDS WEST ALONG SAID NORTHERLY LINE, 35.00 FEET; THENCE NORTH 31 DEGREES 07 MINUTES 20 SECONDS EAST, 68.97 FEET TO SAID WESTERLY LINE OF CASS AVENUE; THENCE SOUTH 01 DEGREES 29 MINUTES 05 SECONDS EAST ALONG SAID WESTERLY LINE, 35.00 FEET TO THE POINT OF BEGINNING, ALL IN DUPAGE COUNTY, ILLINOIS.

PARENT PARCEL DESCRIPTION:
THAT PART OF LOT 302, DESCRIBED AS FOLLOWS: BEGINNING AT THE INTERSECTION OF THE NORTHERLY LINE OF PLAINFIELD ROAD AND THE WESTERLY LINE OF CASS AVENUE; THENCE WESTERLY ALONG THE NORTHERLY LINE OF PLAINFIELD ROAD, 155 FEET; THENCE NORTHERLY AND PARALLEL WITH CASS AVENUE, 210.00 FEET; THENCE EASTERLY ON A LINE PERPENDICULAR TO CASS AVENUE, 145 FEET TO A POINT ON THE WESTERLY LINE OF CASS AVENUE; THENCE SOUTHERLY ALONG THE WESTERLY LINE OF CASS AVENUE 145 FEET TO THE PLACE OF BEGINNING, IN BROOKHAVEN MANOR, A SUBDIVISION IN SECTIONS 27 AND 28, TOWNSHIP 28 NORTH, RANGE 11 EAST OF THE THIRD PRINCIPAL MERIDIAN, ACCORDING TO THE PLAT THEREOF RECORDED DECEMBER 18, 1956 AS DOCUMENT 827287, IN DUPAGE COUNTY, ILLINOIS.

OWNER'S CERTIFICATE

STATE OF _____ SS
COUNTY OF _____

THIS IS TO CERTIFY THAT _____ IS THE HOLDER OF RECORD TITLE TO THE PROPERTY DESCRIBED HEREON, AND HAS CAUSED THE SAME TO BE SURVEYED AND PLATTED, AS SHOWN BY THIS PLAT FOR THE USES AND PURPOSES HEREIN SET FORTH AND THAT SAID OWNER HEREBY ACKNOWLEDGE AND ADOPTS THE SAME UNDER THE STYLE AND TITLE HEREON SHOWN.

DATED THIS _____ DAY OF _____ A.D. 20____

(NAME)

(TITLE)

(ADDRESS)

CITY COUNCIL CERTIFICATE

STATE OF ILLINOIS SS
COUNTY OF DUPAGE

APPROVED BY THE MAYOR AND CITY COUNCIL OF THE CITY OF DARIEN, DUPAGE COUNTY, ILLINOIS.

THIS _____ DAY OF _____, A.D. 20____

MAYOR

CLERK

DUPAGE COUNTY RECORDER

STATE OF ILLINOIS SS
COUNTY OF DUPAGE

THIS PLAT WAS FILED FOR RECORD IN THE RECORDER'S OFFICE OF DUPAGE COUNTY, ILLINOIS ON THE _____ DAY OF _____ A.D. 20____ AT _____ O'CLOCK _____ M. AS DOCUMENT NUMBER _____

DUPAGE COUNTY RECORDER

NOTARY'S CERTIFICATE

STATE OF ILLINOIS SS
COUNTY OF _____

I, _____, A NOTARY PUBLIC IN AND FOR SAID COUNTY, IN THE STATE AFORESAID, DO CERTIFY THAT _____ PERSONALLY KNOWN TO ME TO BE THE SAME PERSONS WHOSE NAMES ARE SUBSCRIBED TO THE FOREGOING INSTRUMENT AS SUCH OWNERS, APPEARED BEFORE ME THIS DAY IN PERSON AND ACKNOWLEDGED THAT THEY SIGNED AND DELIVERED THE ANNEXED PLAT AS THEIR OWN FREE AND VOLUNTARY ACT FOR THE USES AND PURPOSES THEREIN SET FORTH.

GIVEN UNDER MY HAND AND NOTARIAL SEAL THIS _____ DAY OF _____

NOTARY PUBLIC
MY COMMISSION EXPIRES: _____

PERMISSION TO RECORD CERTIFICATE

STATE OF ILLINOIS SS
COUNTY OF COOK

I, FRANJO I. MATIĆ, ILLINOIS PROFESSIONAL LAND SURVEYOR #035-003556, HEREBY AUTHORIZE AN AGENT OF THE CITY OF DARIEN AND/OR ITS DESIGNATED AGENTS TO RECORD THIS PLAT OF EASEMENT WITH THE OFFICE OF THE DUPAGE COUNTY RECORDER OF DEEDS.

GIVEN UNDER OUR HAND AND SEAL THIS 28TH DAY OF JULY, A.D. 2020, AT HOFFMAN ESTATES, ILLINOIS.

FRANJO I. MATIĆ - PLS #035-003556 EXPIRES 11/30/2020
ILLINOIS PROFESSIONAL DESIGN FIRM LICENSE NO. 184.007570-0015

SURVEYORS CERTIFICATE

STATE OF ILLINOIS SS
COUNTY OF COOK

I, FRANJO I. MATIĆ, ILLINOIS PROFESSIONAL LAND SURVEYOR #035-003556, HAVE SURVEYED AND PREPARED THE GRANT OF EASEMENT FOR THE PROPERTY DESCRIBED ABOVE AS SHOWN BY THE ANNEXED PLAT WHICH IS A CORRECT AND TRUE REPRESENTATION OF SAID SURVEY AND PLAT OF EASEMENT GRANT, ALL DISTANCES ARE SHOWN IN FEET AND DECIMAL PARTS THEREOF.

I FURTHER CERTIFY THAT ALL REGULATIONS ENACTED BY THE MAYOR AND CITY COUNCIL OF DARIEN RELATIVE TO PLATS AND SUBDIVISIONS HAVE BEEN COMPLIED WITH IN PREPARATION OF THIS PLAT. I FURTHER CERTIFY THAT THE LAND IS WITHIN THE CITY OF DARIEN (OR WITHIN ONE AND ONE HALF MILES OF THE CORPORATE LIMITS OF THE CITY OF DARIEN) WHICH HAS ADOPTED A CITY COMPREHENSIVE PLAN AND MAP AND IS EXERCISING THE SPECIAL POWERS AUTHORIZED BY DIVISION 12 OF ARTICLE 11 OF THE ILLINOIS MUNICIPAL CODE AS HERETOFORE AND HEREAFTER AMENDED.

GIVEN UNDER OUR HAND AND SEAL THIS 28TH DAY OF JULY, A.D. 2020, AT HOFFMAN ESTATES, ILLINOIS.

FRANJO I. MATIĆ - PLS #035-003556 EXPIRES 11/30/2020
ILLINOIS PROFESSIONAL DESIGN FIRM LICENSE NO. 184.007570-0015



AQUATIC \ CIVIL \ MECHANICAL \ ELECTRICAL \ PLUMBING \ TELECOMMUNICATION \ STRUCTURAL \ ACCESSIBILITY CONSULTING \ DESIGN & PROGRAM MANAGEMENT \ LAND SURVEY

EASE-1
PLAT OF EASEMENT
SHEET 1 OF 1

JOB: 20171965
DRAWN: KICM
CHECKED: M
DATE: 7/27/20

CASS AVENUE AND PLAINFIELD ROAD
DARIEN, ILLINOIS



WT GROUP
Engineering with Precision, Pace and Passion.

2875 Pratum Avenue | Hoffman Estates, IL 60192
T: 224.293.6333 | F: 224.293.6444
wtegrouping.com

IL License No: 184.007570-0015 Expires: 04.30.2021
© COPYRIGHT 2020 THE WT GROUP, LLC



Attachment B

JOB LOCATION	7532 CASS AVE LLC & CITY OF DARIEN LANDSCAPE FEATURE COST ESTIMATE						
DESCRIPTION	QUANTITY	UNIT	UNIT PRICE	TOTAL COST	ACTUAL UNITS	FINAL COST	AWARDED VENDOR
SAVANAH GROUP	1	NOT TO EXCEED SEE ATT 1-FOR COST BREAKDOWN	\$ 32,000.00	\$ 32,000.00	-	\$ -	
IRRIGATION	1	LUMP SUM	\$ 4,500.00	\$ 4,500.00	-	\$ -	
OLYMPIC SIGN	2	LUMP SUM SEE ATT 2 -WELCOME TO THE CITY OF DARIEN LETTERS	\$ 4,498.00	\$ 4,498.00	-	\$ -	
SUB TOTAL COST				\$ 40,998.00			
CONTINGENCY	1	LUMP SUM	\$ 4,500.00	\$ 4,500.00			
TOTAL COST				\$ 45,498.00			
CITY COST		COST SHARE		\$ 22,749.00			
7532 CASS AVE LLC				\$ 22,749.00			

The Savanna Group Inc.

P.O. Box 726

North Aurora, IL 60542

Estimate

DATE	ESTIMATE #
7/14/2020	100576

NAME / ADDRESS
Daniel Gombac

PROJECT

DESCRIPTION	QTY	COST	TOTAL
Option #3		0.00	0.00
Number of 36" Dwf. Globe Blue Spruce's installed.	2	662.00	1,324.00
Number of 24" Spirea installed. (Red Blooming)	32	46.00	1,472.00
Number of 1 gallon Ornamental Grasses installed. (Karl Forester)	32	16.00	512.00
Number of 3" pots of Groundcover installed. (Super Blue Lavender)	240	3.25	780.00
C.Y. of Mulch installed.	14	60.00	840.00
C.Y. of Topsoil installed.	40	60.00	2,400.00
S.F. of Estate Stone Wall installed. (6" stones only as the 3" stones have been discontinued by manufacture.) (Color to match existing)	210	47.00	9,870.00
S.F. of Estate Stone Wall installed to create stone base for new sign.	84	47.00	3,948.00
Installation of concrete pad for new stone base of sign	1	1,500.00	1,500.00
Installation of Pondless waterfall with 2 streams that cut through Estate retaining wall. (Includes outcropping stone)	1	9,400.00	9,400.00
		TOTAL	\$32,046.00

Dan Gombac

From: Rob Whitehead <rwhitehead@olysigns.com>
Sent: Wednesday, July 22, 2020 2:37 PM
To: Dan Gombac
Subject: RE: Landscape concept-Plainfield Rd and Cass Ave
Attachments: BROOKHAVEN PLAZA Darien IL 20-8343 07 22 20.pdf

Hi Dan

Please see the attached drawings for the Aluminum letters for the wall . There are OPTION #1 & 2 on page 7 Option #1\$ 4,280.00 Option#2 \$ 4,498.00 Please let me know if any questions or changes.

Thank you Sir!

Robert J. Whitehead Sr. | President
Olympik Signs
1130 N. Garfield | Lombard IL 60148
D: (630) 652-4103 | O: (630) 424-6100

Connect with us:
See Olympik on WGN: [Click Here](#)

-----Original Message-----

From: Dan Gombac <dgombac@darienil.gov>
Sent: Wednesday, July 22, 2020 1:19 PM
To: Rob Whitehead <rwhitehead@olysigns.com>
Subject: Re: Landscape concept-Plainfield Rd and Cass Ave

Let's put Welcome to as an option

> On Jul 22, 2020, at 12:53 PM, Rob Whitehead <rwhitehead@olysigns.com> wrote:

>

> Ok should I drop the words Welcome to? and just have CITY OF DARIEN

>

> Robert J. Whitehead Sr. | President

> Olympik Signs

> 1130 N. Garfield | Lombard IL 60148

> D: (630) 652-4103 | O: (630) 424-6100

>

> Connect with us:

> See Olympik on WGN: [Click Here](#)

>

> -----Original Message-----

> From: Dan Gombac <dgombac@darienil.gov>

> Sent: Wednesday, July 22, 2020 12:42 PM

> To: Rob Whitehead <rwhitehead@olysigns.com>

> Cc: Manos, John <JManos@bankfinancial.com>; Pamela Folk <PFolk@olysigns.com>; Savannagroup <savannagroup@comcast.net>

> Subject: Re: Landscape concept-Plainfield Rd and Cass Ave

OPTION #1

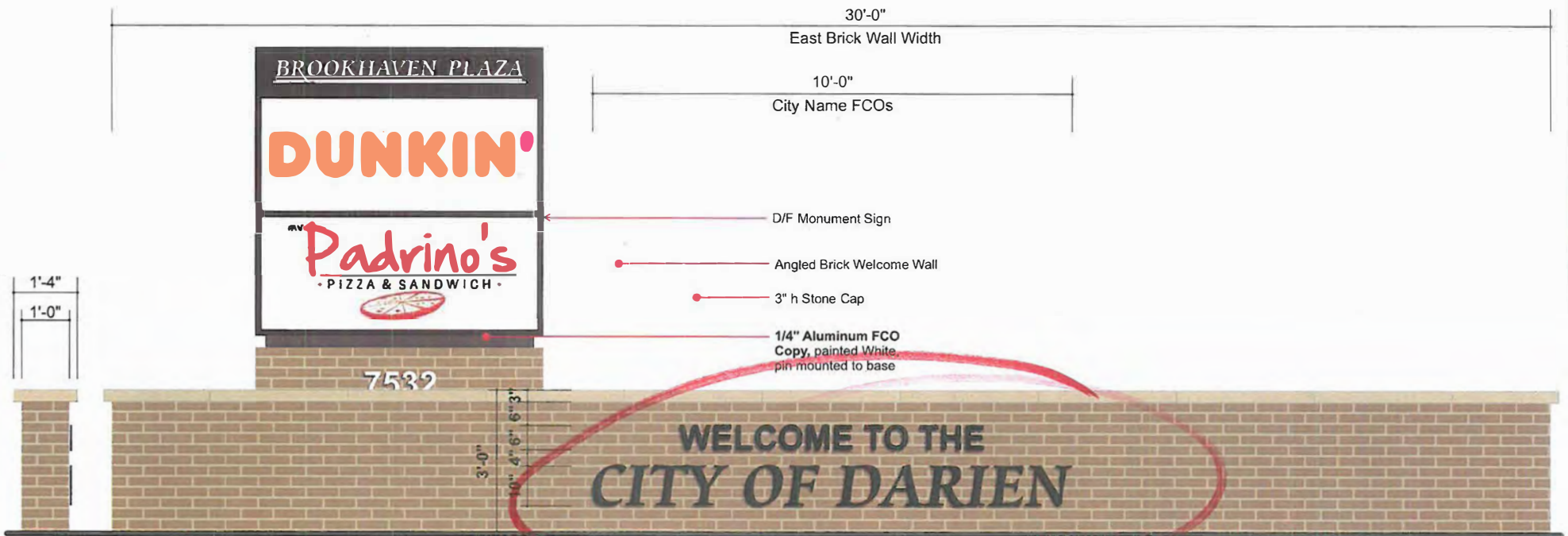

Side View Front View

EAST Elevation - Brick Welcome Wall -

Scale 1/2" = 1'-0"
Qty: (2) Sets of FCOs Required
Drawing for concept purposes only. Field survey required prior to fabrication.

BROOKHAVEN PLAZA



account representative client
ROB WHITEHEAD 7532 S Cass Avenue
Darien, IL 60561

1130 N. Garfield
Lombard, IL 60148 Ph.# 630.424.6100 Fx.# 630.424.6120

WWW.OLYSIGNS.COM

drawn by job#: 20-8343
PAMELA F • 06-26-20
• rev.# 07-22-20

Comments:

WELCOME WALL

THIS IS AN ORIGINAL, UNPUBLISHED DRAWING SUBMITTED IN CONNECTION WITH A PROJECT WE ARE PLANNING FOR YOU. THIS IS NOT TO BE COPIED, REPRODUCED, EXHIBITED OR SHOWN TO ANYONE OUTSIDE OF YOUR ORGANIZATION WITHOUT THE WRITTEN PERMISSION OF OLYMPIC SIGNS, INC. ARTWORK IS EXCLUSIVE PROPERTY OF OLYMPIC SIGNS, INC.

RESOLUTION NO. _____

**A RESOLUTION ACCEPTING A PLAT OF EASEMENT FOR A LANDSCAPE
FEATURE, (NORTHWEST CORNER OF CASS AVENUE AND PLAINFIELD ROAD) AT
7532 CASS AVENUE, PIN# 09-28-402-025**

**BE IT RESOLVED BY THE CITY COUNCIL OF THE CITY OF DARIEN, DU PAGE
COUNTY, ILLINOIS**, as follows:

SECTION 1: The City Council of the City of Darien hereby authorizes the Mayor and City Clerk to accept a Plat of Easement for a Landscape Feature, (Northwest Corner of Cass Avenue and Plainfield Road) at 7532 Cass Avenue, PIN# 09-28-402-025, a copy of which is attached here to as "**Exhibit 1**" and is by this reference expressly incorporated herein.

SECTION 2: This Resolution shall be in full force and effect from and after its passage and approval as provided by law.

**PASSED BY THE CITY COUNCIL OF THE CITY OF DARIEN, DU PAGE COUNTY,
ILLINOIS**, this 3rd day of August, 2020.

AYES: _____

NAYS: _____

ABSENT: _____

**APPROVED BY THE MAYOR OF THE CITY OF DARIEN, DU PAGE COUNTY,
ILLINOIS**, this 3rd day of August 2020.

JOSEPH A. MARCHESE, MAYOR

ATTEST:

JOANNE E. RAGONA, CITY CLERK

APPROVED AS TO FORM:

CITY ATTORNEY

PLAT OF EASEMENT

SUBMITTED BY AND RETURN TO:
CITY OF DARIEN
1702 PLAINFIELD ROAD
DARIEN, IL 60561

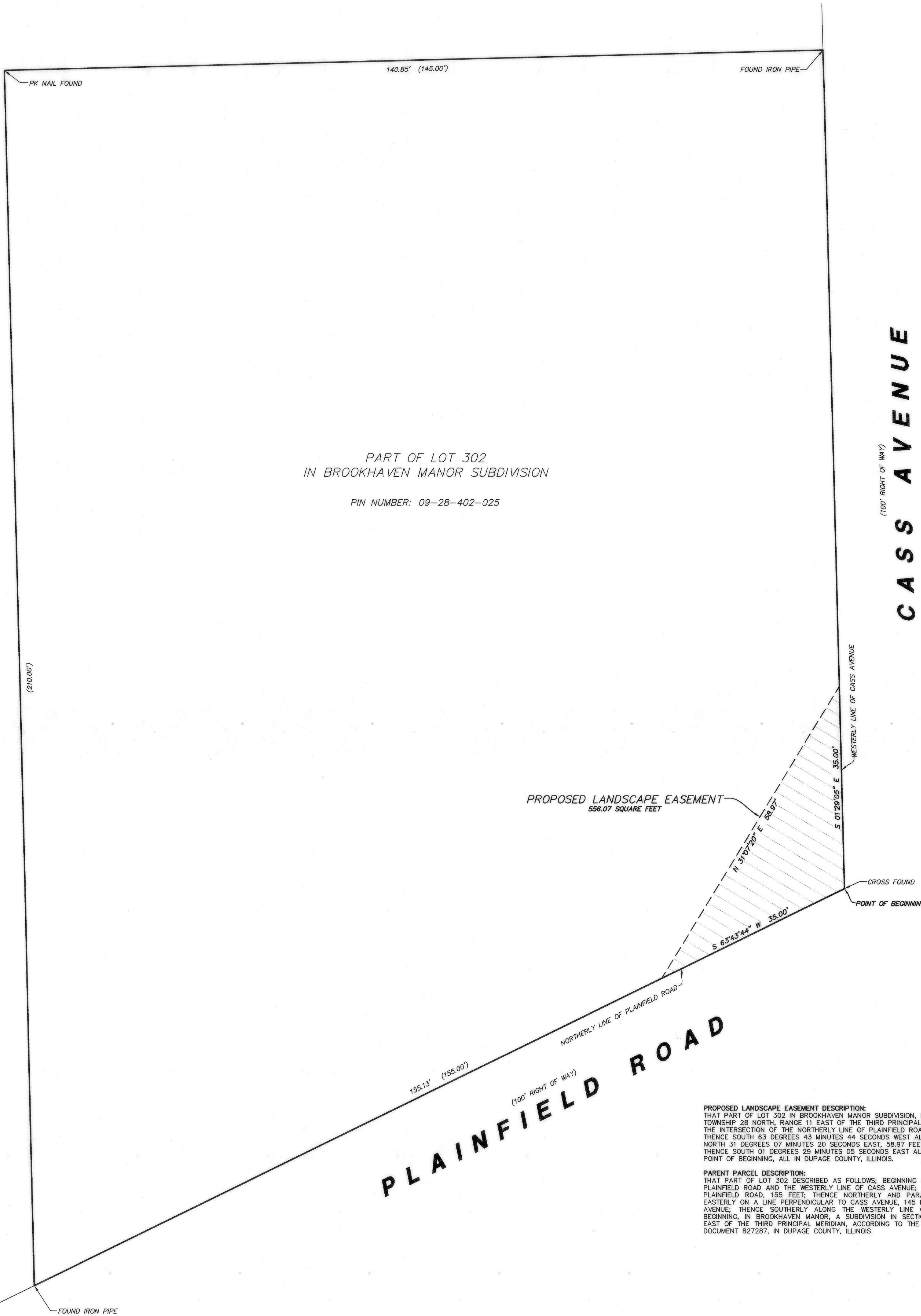

PART OF LOT 302
IN BROOKHAVEN MANOR SUBDIVISION
PIN NUMBER: 09-28-402-025

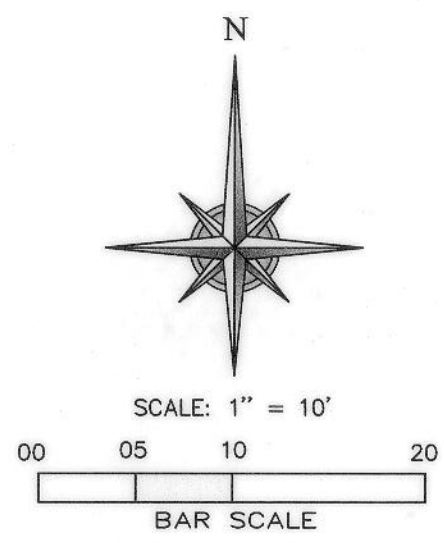

PROPOSED LANDSCAPE EASEMENT DESCRIPTION:
THAT PART OF LOT 302 IN BROOKHAVEN MANOR SUBDIVISION, BEING A SUBDIVISION IN SECTIONS 27 AND 28, TOWNSHIP 28 NORTH, RANGE 11 EAST OF THE THIRD PRINCIPAL MERIDIAN, DESCRIBED AS FOLLOWS: BEGINNING AT THE INTERSECTION OF THE NORTHERLY LINE OF PLAINFIELD ROAD AND THE WESTERLY LINE OF CASS AVENUE; THENCE SOUTH 63 DEGREES 43 MINUTES 44 SECONDS WEST ALONG SAID NORTHERLY LINE, 35.00 FEET; THENCE NORTH 31 DEGREES 07 MINUTES 20 SECONDS EAST, 68.97 FEET TO SAID WESTERLY LINE OF CASS AVENUE; THENCE SOUTH 01 DEGREES 29 MINUTES 05 SECONDS EAST ALONG SAID WESTERLY LINE, 35.00 FEET TO THE POINT OF BEGINNING, ALL IN DUPAGE COUNTY, ILLINOIS.

PARENT PARCEL DESCRIPTION:
THAT PART OF LOT 302, DESCRIBED AS FOLLOWS: BEGINNING AT THE INTERSECTION OF THE NORTHERLY LINE OF PLAINFIELD ROAD AND THE WESTERLY LINE OF CASS AVENUE; THENCE WESTERLY ALONG THE NORTHERLY LINE OF PLAINFIELD ROAD, 155 FEET; THENCE NORTHERLY AND PARALLEL WITH CASS AVENUE, 210.00 FEET; THENCE EASTERLY ON A LINE PERPENDICULAR TO CASS AVENUE, 145 FEET TO A POINT ON THE WESTERLY LINE OF CASS AVENUE; THENCE SOUTHERLY ALONG THE WESTERLY LINE OF CASS AVENUE 145 FEET TO THE PLACE OF BEGINNING, IN BROOKHAVEN MANOR, A SUBDIVISION IN SECTIONS 27 AND 28, TOWNSHIP 28 NORTH, RANGE 11 EAST OF THE THIRD PRINCIPAL MERIDIAN, ACCORDING TO THE PLAT THEREOF RECORDED DECEMBER 18, 1956 AS DOCUMENT 827287, IN DUPAGE COUNTY, ILLINOIS.

OWNER'S CERTIFICATE

STATE OF _____ SS
COUNTY OF _____

THIS IS TO CERTIFY THAT _____ IS THE HOLDER OF RECORD TITLE TO THE PROPERTY DESCRIBED HEREON, AND HAS CAUSED THE SAME TO BE SURVEYED AND PLATTED, AS SHOWN BY THIS PLAT FOR THE USES AND PURPOSES HEREIN SET FORTH AND THAT SAID OWNER HEREBY ACKNOWLEDGE AND ADOPTS THE SAME UNDER THE STYLE AND TITLE HEREON SHOWN.

DATED THIS _____ DAY OF _____ A.D. 20____

(NAME)

(TITLE)

(ADDRESS)

CITY COUNCIL CERTIFICATE

STATE OF ILLINOIS SS
COUNTY OF DUPAGE

APPROVED BY THE MAYOR AND CITY COUNCIL OF THE CITY OF DARIEN, DUPAGE COUNTY, ILLINOIS.

THIS _____ DAY OF _____, A.D. 20____

MAYOR

CLERK

DUPAGE COUNTY RECORDER

STATE OF ILLINOIS SS
COUNTY OF DUPAGE

THIS PLAT WAS FILED FOR RECORD IN THE RECORDER'S OFFICE OF DUPAGE COUNTY, ILLINOIS ON THE _____ DAY OF _____ A.D. 20____ AT _____ O'CLOCK _____ M. AS DOCUMENT NUMBER _____

DUPAGE COUNTY RECORDER

NOTARY'S CERTIFICATE

STATE OF ILLINOIS SS
COUNTY OF _____

I, _____, A NOTARY PUBLIC IN AND FOR SAID COUNTY, IN THE STATE AFORESAID, DO CERTIFY THAT _____ PERSONALLY KNOWN TO ME TO BE THE SAME PERSONS WHOSE NAMES ARE SUBSCRIBED TO THE FOREGOING INSTRUMENT AS SUCH OWNERS, APPEARED BEFORE ME THIS DAY IN PERSON AND ACKNOWLEDGED THAT THEY SIGNED AND DELIVERED THE ANNEXED PLAT AS THEIR OWN FREE AND VOLUNTARY ACT FOR THE USES AND PURPOSES THEREIN SET FORTH.

GIVEN UNDER MY HAND AND NOTARIAL SEAL THIS _____ DAY OF _____

NOTARY PUBLIC
MY COMMISSION EXPIRES: _____

PERMISSION TO RECORD CERTIFICATE

STATE OF ILLINOIS SS
COUNTY OF COOK

I, FRANJO I. MATIĆ, ILLINOIS PROFESSIONAL LAND SURVEYOR #035-003556, HEREBY AUTHORIZE AN AGENT OF THE CITY OF DARIEN AND/OR ITS DESIGNATED AGENTS TO RECORD THIS PLAT OF EASEMENT WITH THE OFFICE OF THE DUPAGE COUNTY RECORDER OF DEEDS.

GIVEN UNDER OUR HAND AND SEAL THIS 28TH DAY OF JULY, A.D. 2020, AT HOFFMAN ESTATES, ILLINOIS.

FRANJO I. MATIĆ - PLS #035-003556 EXPIRES 11/30/2020
ILLINOIS PROFESSIONAL DESIGN FIRM LICENSE NO. 184.007570-0015

SURVEYORS CERTIFICATE

STATE OF ILLINOIS SS
COUNTY OF COOK

I, FRANJO I. MATIĆ, ILLINOIS PROFESSIONAL LAND SURVEYOR #035-003556, HAVE SURVEYED AND PREPARED THE GRANT OF EASEMENT FOR THE PROPERTY DESCRIBED ABOVE AS SHOWN BY THE ANNEXED PLAT WHICH IS A CORRECT AND TRUE REPRESENTATION OF SAID SURVEY AND PLAT OF EASEMENT GRANT, ALL DISTANCES ARE SHOWN IN FEET AND DECIMAL PARTS THEREOF.

I FURTHER CERTIFY THAT ALL REGULATIONS ENACTED BY THE MAYOR AND CITY COUNCIL OF DARIEN RELATIVE TO PLATS AND SUBDIVISIONS HAVE BEEN COMPLIED WITH IN PREPARATION OF THIS PLAT. I FURTHER CERTIFY THAT THE LAND IS WITHIN THE CITY OF DARIEN (OR WITHIN ONE AND ONE HALF MILES OF THE CORPORATE LIMITS OF THE CITY OF DARIEN) WHICH HAS ADOPTED A CITY COMPREHENSIVE PLAN AND MAP AND IS EXERCISING THE SPECIAL POWERS AUTHORIZED BY DIVISION 12 OF ARTICLE 11 OF THE ILLINOIS MUNICIPAL CODE AS HERETOFORE AND HEREAFTER AMENDED.

GIVEN UNDER OUR HAND AND SEAL THIS 28TH DAY OF JULY, A.D. 2020, AT HOFFMAN ESTATES, ILLINOIS.

FRANJO I. MATIĆ - PLS #035-003556 EXPIRES 11/30/2020
ILLINOIS PROFESSIONAL DESIGN FIRM LICENSE NO. 184.007570-0015



AQUATIC \ CIVIL \ MECHANICAL \ ELECTRICAL \ PLUMBING \ TELECOMMUNICATION \ STRUCTURAL \ ACCESSIBILITY CONSULTING \ DESIGN & PROGRAM MANAGEMENT \ LAND SURVEY

EASE-1
PLAT OF EASEMENT
SHEET 1 OF 1

TO	DATE
CLIENT	7/27/20
CLIENT	7/28/20
ISSUE	

CASS AVENUE AND PLAINFIELD ROAD
DARIEN, ILLINOIS



WT GROUP
Engineering with Precision, Pace and Passion.
2875 Pratum Avenue | Hoffman Estates, IL 60192
T: 224.293.6333 | F: 224.293.6444
wtegrouping.com
IL License No: 184.007570-0015 Expires: 04.30.2021
© COPYRIGHT 2020 THE WT GROUP, LLC

RESOLUTION NO. _____

**A RESOLUTION FOR A LANDSCAPE FEATURE AGREEMENT AND A DEDICATED
EASEMENT AT THE NORTHWEST CORNER AT 7532 CASS AVENUE,
PIN# 09-28-402-025**

**BE IT RESOLVED BY THE CITY COUNCIL OF THE CITY OF DARIEN, DU PAGE
COUNTY, ILLINOIS**, as follows:

SECTION 1: The City Council of the City of Darien hereby authorizes the Mayor and City Clerk to approve a Landscape Feature Agreement and a dedicated easement at the northwest corner at 7532 Cass Avenue, PIN# 09-28-402-025., a copy of which is attached here to as “[Exhibit 1](#)” and is by this reference expressly incorporated herein.

SECTION 2: This Resolution shall be in full force and effect from and after its passage and approval as provided by law.

**PASSED BY THE CITY COUNCIL OF THE CITY OF DARIEN, DU PAGE COUNTY,
ILLINOIS**, this 3rd day of August 2020.

AYES: _____

NAYS: _____

ABSENT: _____

**APPROVED BY THE MAYOR OF THE CITY OF DARIEN, DU PAGE COUNTY,
ILLINOIS**, this 3rd day of August 2020.

JOSEPH A. MARCHESE, MAYOR

ATTEST:

JOANNE E. RAGONA, CITY CLERK

APPROVED AS TO FORM:

CITY ATTORNEY

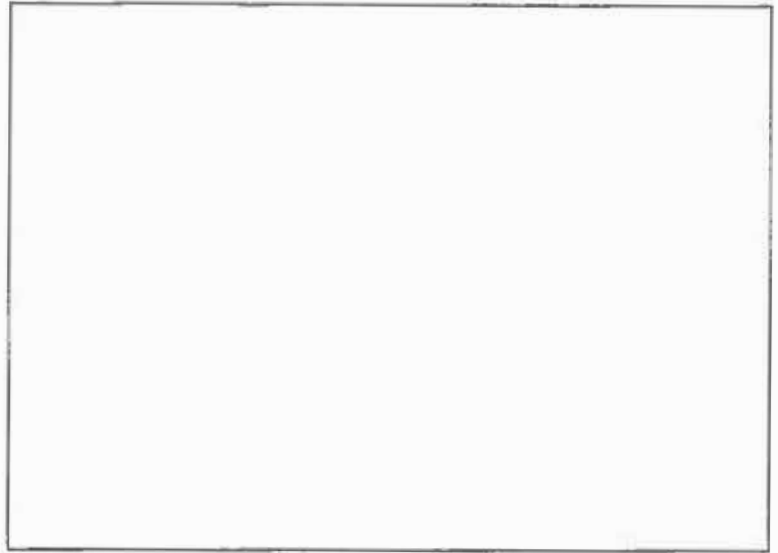

EASEMENT AGREEMENT

THIS EASEMENT AGREEMENT (“Agreement”) is dated the ____ day of _____, 2020, by and between 7532 Cass Avenue L.L.C. (“Owner”) and the City of Darien, a municipal corporation with offices at 1702 Plainfield Road, Darien, Illinois 60561 (“City”).

RECITALS:

- A. Owner is the owner of certain property described on [Exhibit 1](#) attached hereto and made a part hereof (the “Subject Property”).
- B. Owner is in the process of developing the Subject Property for commercial use.
- C. The Subject Property fronts both Cass Avenue and Plainfield Road within the City. The City and Owner have been in negotiations in order to collaborate on the installation and maintenance of decorative landscaping features on the “Easement Area” defined below.
- D. In connection with the Agreement, the parties have agreed that Owner will grant the City temporary and permanent easements as set forth hereinbelow.

Accordingly, it is hereby agreed by and between Owner and City as follows:

Section 1. Grant of Easement. Owner hereby grants the City an easement to the “Easement Area” as shown on the Plat attached to this Agreement as [Exhibit 2](#) for purposes of maintaining decorative landscaping features within the Easement Area. An illustration of the landscape features is shown on [Exhibit 3](#).

Section 2. Construction; Maintenance; Cost Sharing

- A. Owner shall be responsible for the construction of the landscape features. The landscape feature plans shall be subject to the City's review and approval. The City will reimburse Owner for 50% of the landscape feature construction cost, up to a maximum City reimbursement obligation of \$27,500.00.
- B. The City shall be solely responsible for the maintenance of the Easement Area. The City and Owner will share the maintenance costs on a 50-50 basis.
- C. The City may assign maintenance responsibilities to a third-party contractor.
- D. Owner shall be responsible for energy costs in connection with the landscaping features. The City will be responsible for all costs connected with providing water for the landscape features.

Section 3. Vacation of Easement

The City reserves the right to vacate the Easement granted by this Agreement after 10 years from the date of initial landscaping installation.

Section 4. Recordation

This Agreement shall be recorded in the Office of the DuPage County Recorder of Deeds at the City's expense.

OWNER:

CITY:

7532 Cass Avenue LLC

CITY OF DARIEN

By: _____



By: _____

Attest: _____

JOHN MANOS

Attest: _____

Date: _____

7/29/2020



EXHIBIT 1

Legal Description

Said property is legally described as follows:

PROPOSED LANDSCAPE EASEMENT DESCRIPTION:

THAT PART OF LOT 302 IN BROOKHAVEN MANOR SUBDIVISION, BEING A SUBDIVISION IN SECTIONS 27 AND 28, TOWNSHIP 28 NORTH, RANGE 11 EAST OF THE THIRD PRINCIPAL MERIDIAN, DESCRIBED AS FOLLOWS; BEGINNING AT THE INTERSECTION OF THE NORTHERLY LINE OF PLAINFIELD ROAD AND THE WESTERLY LINE OF CASS AVENUE; THENCE SOUTH 63 DEGREES 43 MINUTES 44 SECONDS WEST ALONG SAID NORTHERLY LINE, 35.00 FEET; THENCE NORTH 31 DEGREES 07 MINUTES 20 SECONDS EAST, 58.97 FEET TO SAID WESTERLY LINE OF CASS AVENUE; THENCE SOUTH 01 DEGREES 29 MINUTES 05 SECONDS EAST ALONG SAID WESTERLY LINE, 35.00 FEET TO THE POINT OF BEGINNING, ALL IN DUPAGE COUNTY, ILLINOIS.

PARENT PARCEL DESCRIPTION:

THAT PART OF LOT 302 DESCRIBED AS FOLLOWS; BEGINNING AT THE INTERSECTION OF THE NORTHERLY LINE OF PLAINFIELD ROAD AND THE WESTERLY LINE OF CASS AVENUE; THENCE WESTERLY ALONG THE NORTHERLY LINE OF PLAINFIELD ROAD, 155 FEET; THENCE NORTHERLY AND PARALLEL WITH CASS AVENUE, 210.00 FEET; THENCE EASTERLY ON A LINE PERPENDICULAR TO CASS AVENUE, 145 FEET TO A POINT ON THE WESTERLY LINE OF CASS AVENUE; THENCE SOUTHERLY ALONG THE WESTERLY LINE OF CASS AVENUE 145 FEET TO THE PLACE OF BEGINNING, IN BROOKHAVEN MANOR, A SUBDIVISION IN SECTIONS 27 AND 28, TOWNSHIP 28 NORTH, RANGE 11 EAST OF THE THIRD PRINCIPAL MERIDIAN, ACCORDING TO THE PLAT THEREOF RECORDED DECEMBER 18, 1956 AS DOCUMENT 827287, IN DUPAGE COUNTY, ILLINOIS.

PIN: 09-28-402-025

The property is located at 7532 South Cass Avenue, Darien, Illinois 60561.

PLAT OF EASEMENT

SUBMITTED BY AND RETURN TO:
CITY OF DARIEN
1702 PLAINFIELD ROAD
DARIEN, IL 60561

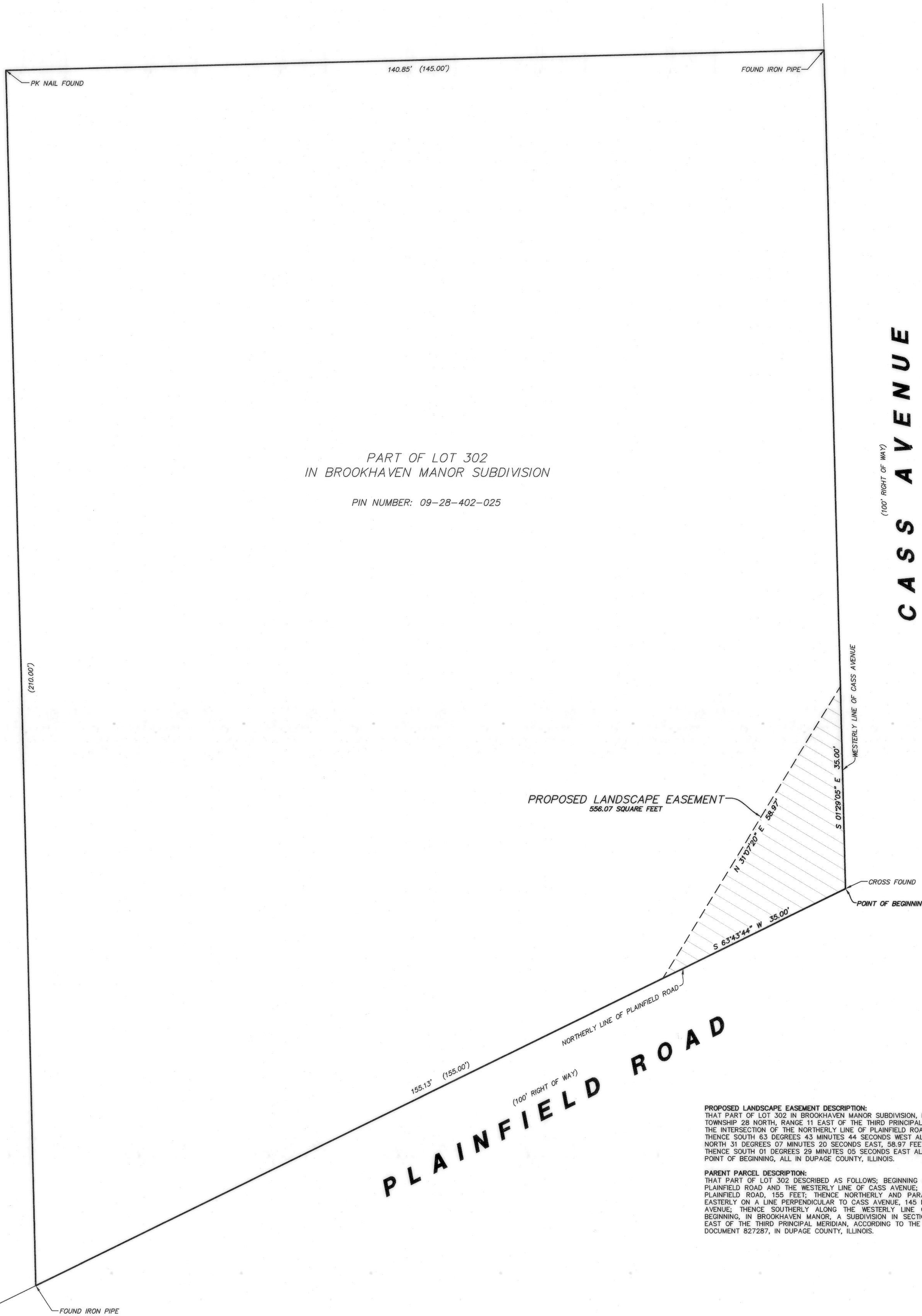

PART OF LOT 302
IN BROOKHAVEN MANOR SUBDIVISION

PIN NUMBER: 09-28-402-025

CASS AVENUE
(100' RIGHT OF WAY)

PLAINFIELD ROAD
(100' RIGHT OF WAY)

PROPOSED LANDSCAPE EASEMENT DESCRIPTION:
THAT PART OF LOT 302 IN BROOKHAVEN MANOR SUBDIVISION, BEING A SUBDIVISION IN SECTIONS 27 AND 28, TOWNSHIP 28 NORTH, RANGE 11 EAST OF THE THIRD PRINCIPAL MERIDIAN, DESCRIBED AS FOLLOWS: BEGINNING AT THE INTERSECTION OF THE NORTHERLY LINE OF PLAINFIELD ROAD AND THE WESTERLY LINE OF CASS AVENUE; THENCE SOUTH 63 DEGREES 43 MINUTES 44 SECONDS WEST ALONG SAID NORTHERLY LINE, 35.00 FEET; THENCE NORTH 31 DEGREES 07 MINUTES 20 SECONDS EAST, 68.97 FEET TO SAID WESTERLY LINE OF CASS AVENUE; THENCE SOUTH 01 DEGREES 29 MINUTES 05 SECONDS EAST ALONG SAID WESTERLY LINE, 35.00 FEET TO THE POINT OF BEGINNING, ALL IN DUPAGE COUNTY, ILLINOIS.

PARENT PARCEL DESCRIPTION:
THAT PART OF LOT 302, DESCRIBED AS FOLLOWS: BEGINNING AT THE INTERSECTION OF THE NORTHERLY LINE OF PLAINFIELD ROAD AND THE WESTERLY LINE OF CASS AVENUE; THENCE WESTERLY ALONG THE NORTHERLY LINE OF PLAINFIELD ROAD, 155 FEET; THENCE NORTHERLY AND PARALLEL WITH CASS AVENUE, 210.00 FEET; THENCE EASTERLY ON A LINE PERPENDICULAR TO CASS AVENUE, 145 FEET TO A POINT ON THE WESTERLY LINE OF CASS AVENUE; THENCE SOUTHERLY ALONG THE WESTERLY LINE OF CASS AVENUE 145 FEET TO THE PLACE OF BEGINNING, IN BROOKHAVEN MANOR, A SUBDIVISION IN SECTIONS 27 AND 28, TOWNSHIP 28 NORTH, RANGE 11 EAST OF THE THIRD PRINCIPAL MERIDIAN, ACCORDING TO THE PLAT THEREOF RECORDED DECEMBER 18, 1956 AS DOCUMENT 827287, IN DUPAGE COUNTY, ILLINOIS.

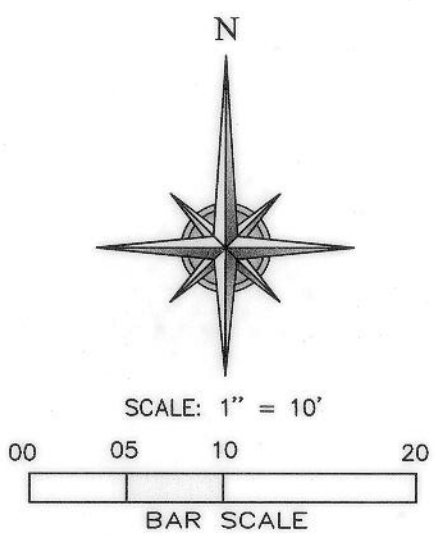

OWNER'S CERTIFICATE

STATE OF _____ SS
COUNTY OF _____

THIS IS TO CERTIFY THAT _____ IS THE HOLDER OF RECORD TITLE TO THE PROPERTY DESCRIBED HEREON, AND HAS CAUSED THE SAME TO BE SURVEYED AND PLATTED, AS SHOWN BY THIS PLAT FOR THE USES AND PURPOSES HEREIN SET FORTH AND THAT SAID OWNER HEREBY ACKNOWLEDGE AND ADOPTS THE SAME UNDER THE STYLE AND TITLE HEREON SHOWN.

DATED THIS _____ DAY OF _____ A.D. 20____

(NAME)

(TITLE)

(ADDRESS)

CITY COUNCIL CERTIFICATE

STATE OF ILLINOIS SS
COUNTY OF DUPAGE

APPROVED BY THE MAYOR AND CITY COUNCIL OF THE CITY OF DARIEN, DUPAGE COUNTY, ILLINOIS.

THIS _____ DAY OF _____, A.D. 20____

MAYOR

CLERK

DUPAGE COUNTY RECORDER

STATE OF ILLINOIS SS
COUNTY OF DUPAGE

THIS PLAT WAS FILED FOR RECORD IN THE RECORDER'S OFFICE OF DUPAGE COUNTY, ILLINOIS ON THE _____ DAY OF _____ A.D. 20____ AT _____ O'CLOCK _____ M. AS DOCUMENT NUMBER _____

DUPAGE COUNTY RECORDER

NOTARY'S CERTIFICATE

STATE OF ILLINOIS SS
COUNTY OF _____

I, _____, A NOTARY PUBLIC IN AND FOR SAID COUNTY, IN THE STATE AFORESAID, DO CERTIFY THAT _____ PERSONALLY KNOWN TO ME TO BE THE SAME PERSONS WHOSE NAMES ARE SUBSCRIBED TO THE FOREGOING INSTRUMENT AS SUCH OWNERS, APPEARED BEFORE ME THIS DAY IN PERSON AND ACKNOWLEDGED THAT THEY SIGNED AND DELIVERED THE ANNEXED PLAT AS THEIR OWN FREE AND VOLUNTARY ACT FOR THE USES AND PURPOSES THEREIN SET FORTH.

GIVEN UNDER MY HAND AND NOTARIAL SEAL THIS _____ DAY OF _____

NOTARY PUBLIC
MY COMMISSION EXPIRES: _____

PERMISSION TO RECORD CERTIFICATE

STATE OF ILLINOIS SS
COUNTY OF COOK

I, FRANJO I. MATIĆ, ILLINOIS PROFESSIONAL LAND SURVEYOR #035-003556, HEREBY AUTHORIZE AN AGENT OF THE CITY OF DARIEN AND/OR ITS DESIGNATED AGENTS TO RECORD THIS PLAT OF EASEMENT WITH THE OFFICE OF THE DUPAGE COUNTY RECORDER OF DEEDS.

GIVEN UNDER OUR HAND AND SEAL THIS 28TH DAY OF JULY, A.D. 2020, AT HOFFMAN ESTATES, ILLINOIS.

FRANJO I. MATIĆ - PLS #035-003556 EXPIRES 11/30/2020
ILLINOIS PROFESSIONAL DESIGN FIRM LICENSE NO. 184.007570-0015

SURVEYORS CERTIFICATE

STATE OF ILLINOIS SS
COUNTY OF COOK

I, FRANJO I. MATIĆ, ILLINOIS PROFESSIONAL LAND SURVEYOR #035-003556, HAVE SURVEYED AND PREPARED THE GRANT OF EASEMENT FOR THE PROPERTY DESCRIBED ABOVE AS SHOWN BY THE ANNEXED PLAT WHICH IS A CORRECT AND TRUE REPRESENTATION OF SAID SURVEY AND PLAT OF EASEMENT GRANT, ALL DISTANCES ARE SHOWN IN FEET AND DECIMAL PARTS THEREOF.

I FURTHER CERTIFY THAT ALL REGULATIONS ENACTED BY THE MAYOR AND CITY COUNCIL OF DARIEN RELATIVE TO PLATS AND SUBDIVISIONS HAVE BEEN COMPLIED WITH IN PREPARATION OF THIS PLAT. I FURTHER CERTIFY THAT THE LAND IS WITHIN THE CITY OF DARIEN (OR WITHIN ONE AND ONE HALF MILES OF THE CORPORATE LIMITS OF THE CITY OF DARIEN) WHICH HAS ADOPTED A CITY COMPREHENSIVE PLAN AND MAP AND IS EXERCISING THE SPECIAL POWERS AUTHORIZED BY DIVISION 12 OF ARTICLE 11 OF THE ILLINOIS MUNICIPAL CODE AS HERETOFORE AND HEREAFTER AMENDED.

GIVEN UNDER OUR HAND AND SEAL THIS 28TH DAY OF JULY, A.D. 2020, AT HOFFMAN ESTATES, ILLINOIS.

FRANJO I. MATIĆ - PLS #035-003556 EXPIRES 11/30/2020
ILLINOIS PROFESSIONAL DESIGN FIRM LICENSE NO. 184.007570-0015



AQUATIC \ CIVIL \ MECHANICAL \ ELECTRICAL \ PLUMBING \ TELECOMMUNICATION \ STRUCTURAL \ ACCESSIBILITY CONSULTING \ DESIGN & PROGRAM MANAGEMENT \ LAND SURVEY

EASE-1
PLAT OF EASEMENT
SHEET 1 OF 1

JOB: 20171965
DRAWN: KICM
CHECKED: M
DATE: 7/27/20
CLIENT: 7/28/20

CASS AVENUE AND PLAINFIELD ROAD
DARIEN, ILLINOIS



WT GROUP
Engineering with Precision, Pace and Passion.
2875 Pratum Avenue | Hoffman Estates, IL 60192
T: 224.293.6333 | F: 224.293.6444
wtegrouping.com
IL License No: 184.007570-0015 Expires: 04.30.2021
© COPYRIGHT 2020 THE WT GROUP, LLC

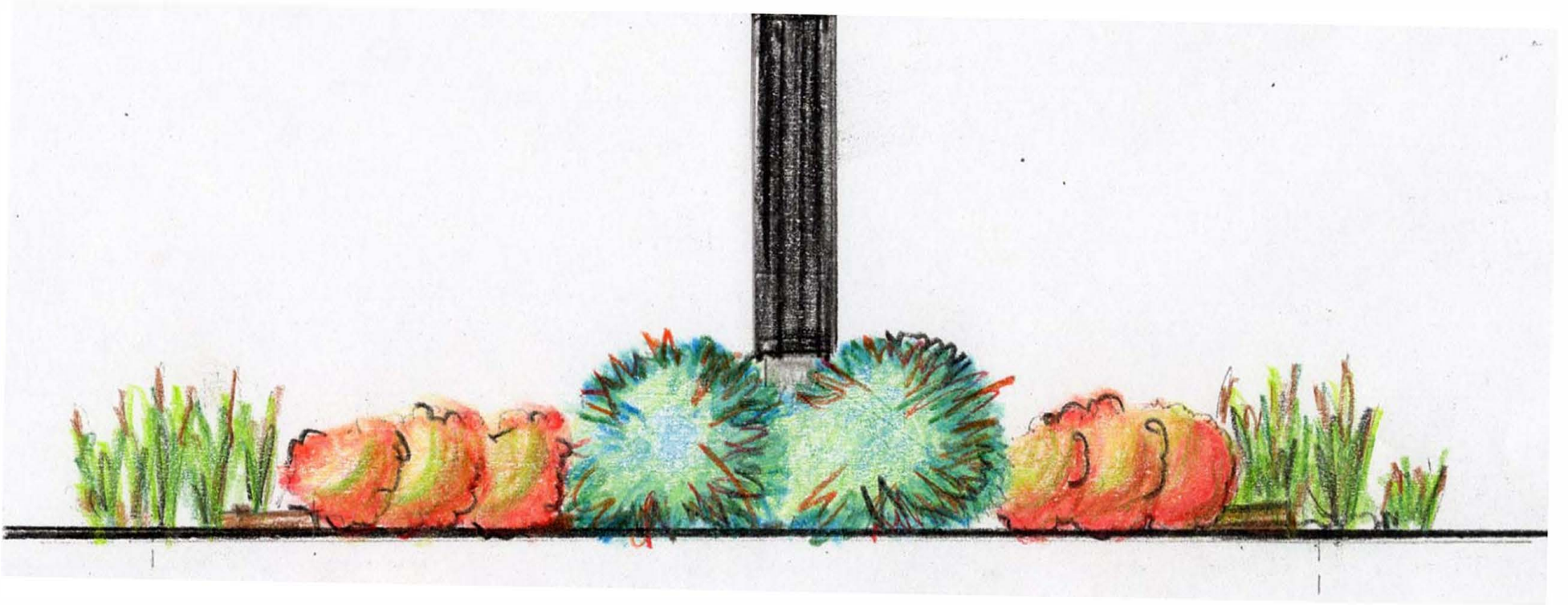

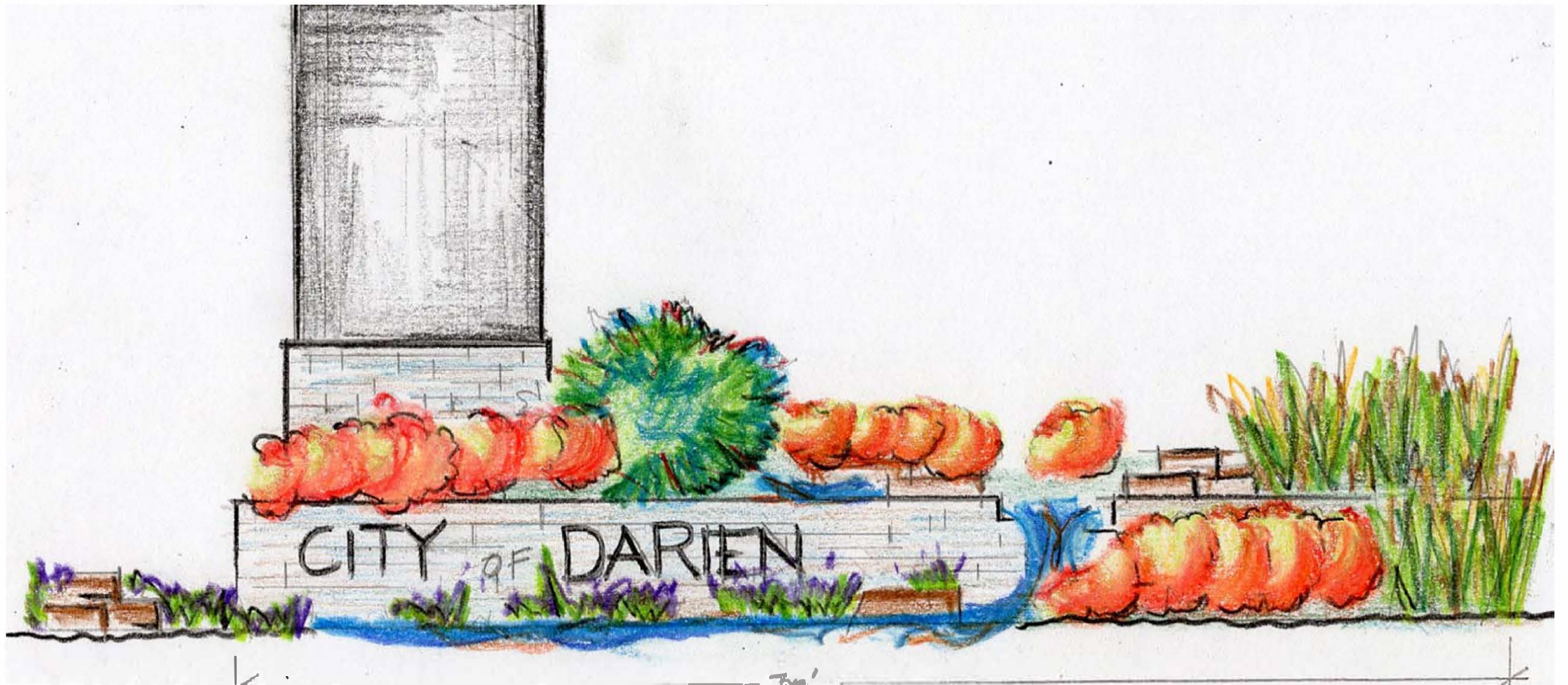

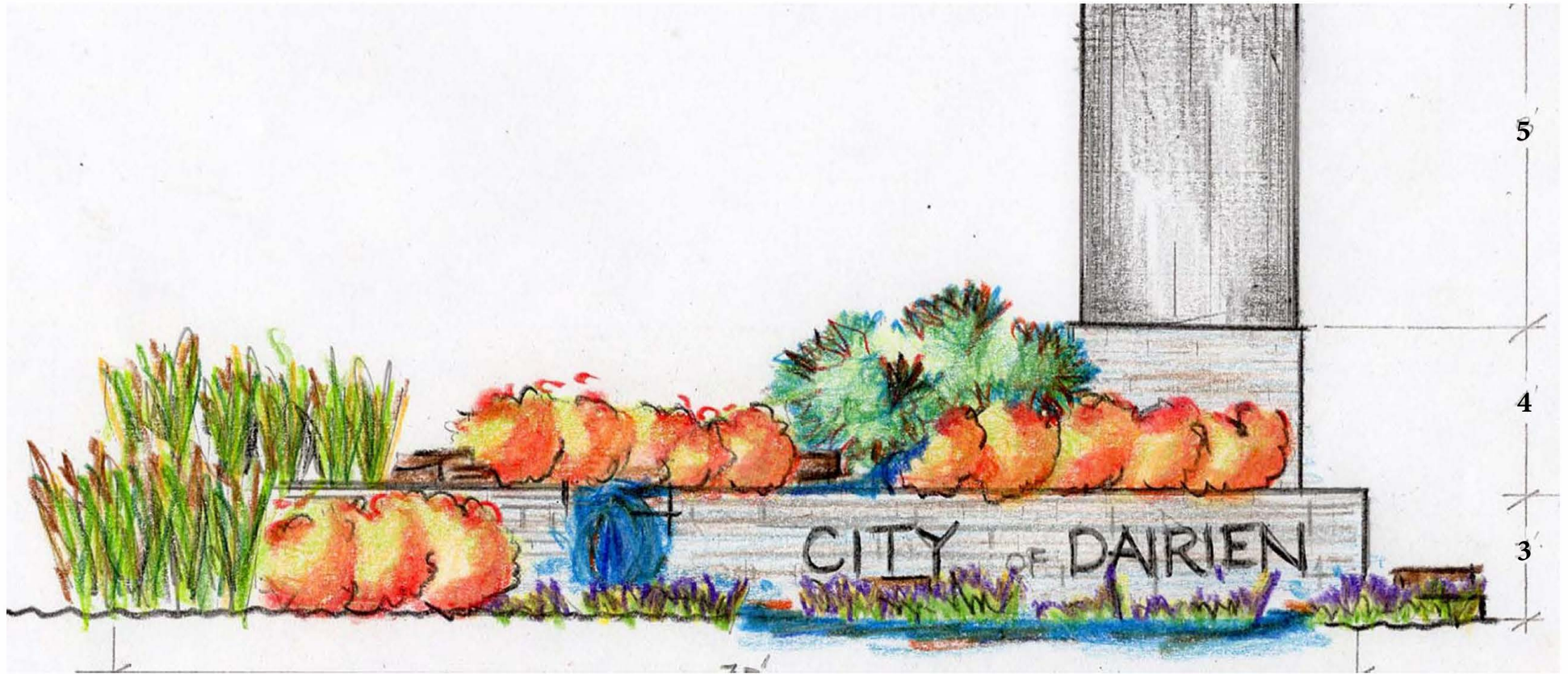

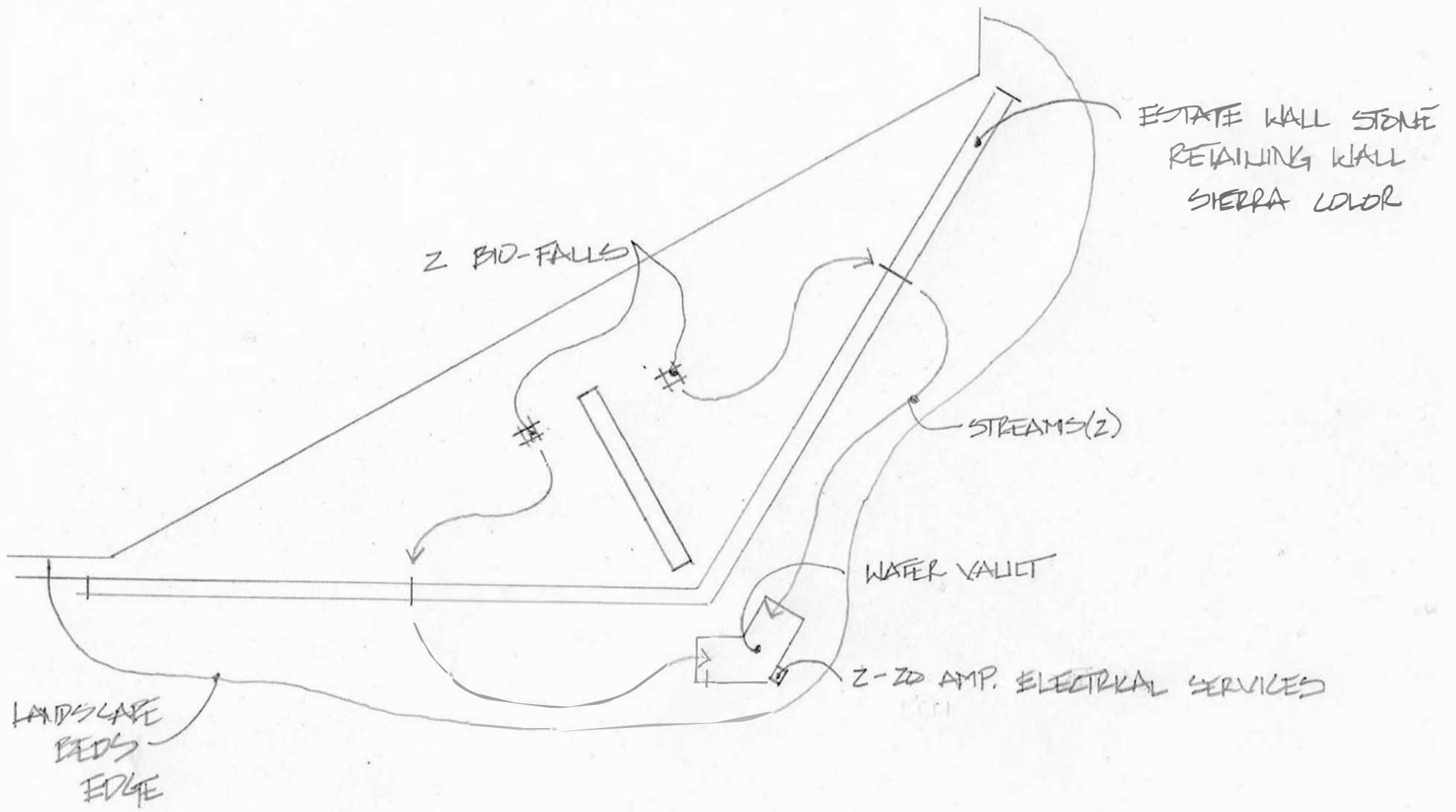

OPTION

#3

SCALE: $\frac{1}{8}'' = 1'-0''$

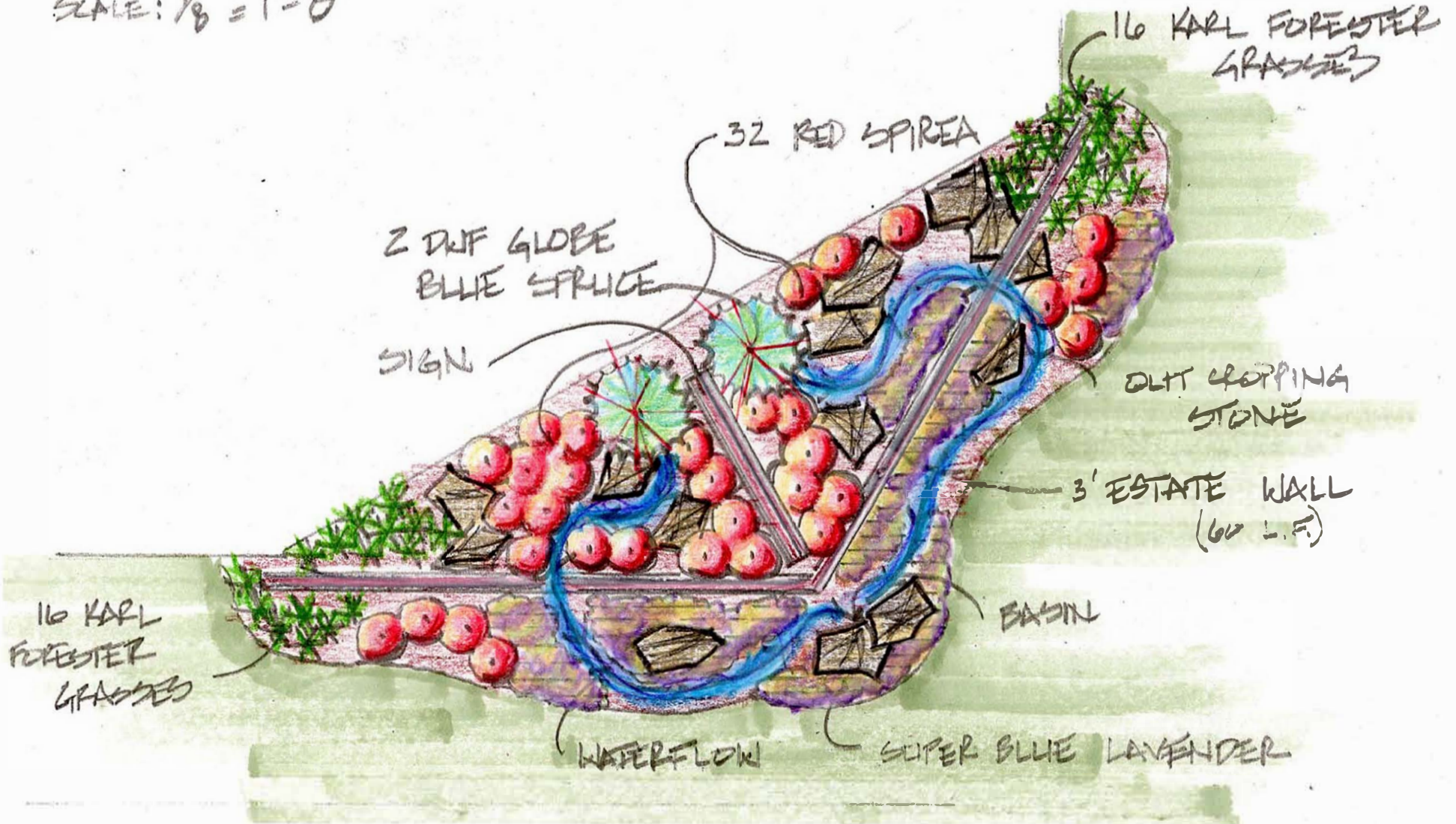



RESOLUTION NO. _____

A RESOLUTION TO REIMBURSE 7532 CASS AVE LLC IN AN AMOUNT NOT TO EXCEED \$22,750 FOR THE CONSTRUCTION OF THE LANDSCAPE FEATURE LOCATED AT 7532 CASS AVE

BE IT RESOLVED BY THE CITY COUNCIL OF THE CITY OF DARIEN, DU PAGE COUNTY, ILLINOIS, as follows:

SECTION 1: The City Council of the City of Darien hereby authorizes the Mayor and City Clerk to reimburse 7532 Cass Ave LLC in an amount not to exceed \$22,750 for the construction of the landscape feature located at 7532 Cass Ave., as per the Landscape Feature Agreement.

SECTION 2: This Resolution shall be in full force and effect from and after its passage and approval as provided by law.

PASSED BY THE CITY COUNCIL OF THE CITY OF DARIEN, DU PAGE COUNTY, ILLINOIS, this 3rd day of August, 2020.

AYES: _____

NAYS: _____

ABSENT: _____

APPROVED BY THE MAYOR OF THE CITY OF DARIEN, DU PAGE COUNTY, ILLINOIS, this 3rd day of August 2020.

JOSEPH A. MARCHESE, MAYOR

ATTEST:

JOANNE E. RAGONA, CITY CLERK

APPROVED AS TO FORM:

CITY ATTORNEY

CITY OF DARIEN

RULES FOR COMPLIANCE WITH PUBLIC COMMENT REQUIREMENTS OF THE ILLINOIS OPEN MEETINGS ACT

I. PURPOSE OF RULES.

The purpose of these Rules is to comply with the requirement of Section 2.06 of the Illinois Open Meetings Act that a public comment section be provided at each meeting subject to the Open Meetings Act.

II. DEFINITION OF “PUBLIC BODY” or “BODY.”

For purposes of these Rules, the term “Public Body” or “Body” shall mean the City Council, any Committee of the City Council, and any Board and Commission established by the City Council.

III. RULES GOVERNING PUBLIC COMMENT.

A. Unless otherwise allowed by a majority vote of the Body, the public comment periods shall be as follows:

1. For the City Council, as set forth on the attached **Agenda template**.
2. For Council committees and advisory committees, at the conclusion of the meeting immediately before adjournment. At the direction of the Body, the floor may be opened for public comment in conjunction with specific agenda items.

B. Individuals seeking to make public comment to the Body shall be formally recognized by the Chair.

C. Individuals addressing the Body shall identify themselves by name, but need not provide their home address.

D. Individuals addressing the Body shall do so by addressing their comments to the Body

itself and shall not turn to address the audience.

E. Public comment time shall be limited to three (3) minutes per person.

F. An individual will be allowed a second opportunity to address the Body only after all other interested persons have addressed the Body and only upon the majority vote of the Body.

G. In the case of a special meeting, public comment will be limited to subject matters germane to the agenda of the special meeting.

IV. PUBLIC HEARING REQUIREMENTS.

Additional public comments periods will be allowed as required by law in the case of public hearing, subject to the same time constraints.

Approved by a Motion on November 17, 2014