

AGENDA
Municipal Services Committee
February 22, 2021
7:00 P.M. – Council Chambers

**CITY OF DARIEN TEMPORARY AMENDMENT TO MUNICIPAL SERVICES COMMITTEE
MEETING FOR COMPLIANCE WITH ILLINOIS OPEN MEETINGS ACT:**

- All Alderpersons will participate in the committee meeting by way of audio or video conferencing.
- The public is permitted to attend the Committee meeting but the meeting room will be limited to twenty members of the public at one time. The public will be required to maintain social distancing rules and are required to wear a mask while in the building.
- The public is encouraged to participate in committee meetings by submitting questions and comments via email to Municipal Services Director Daniel Gombac at dgombac@darienil.gov
- Emails providing public comment shall be submitted prior to the start of the committee meeting.

1. Call to Order & Roll Call

2. Establishment of Quorum

3. Old Business

- a. **Resolution** - Approving the services for a Code Enforcement Officer.

4. New Business

- a. **Resolution** - Authorizing the Mayor to accept a proposal from Christopher B. Burke Engineering, Ltd. for the professional design services related to the Construction Layout Services for the geometrical reconfiguration of 67th Street-adjacent to the western leg of Clarendon Hills Road in an amount not to exceed \$5,000.
- b. **Resolution** - Illinois Department of Transportation authorizing the expenditure of Motor Fuel Tax Funds.
- c. **Resolution** - Illinois Department of Transportation authorizing the expenditure of Rebuild Illinois Bonds Program funds.
- d. **Resolution** – Approval allowing the City of Darien to perform maintenance and emergency work on City owned infrastructure on State of Illinois Highway System, for a period May 1, 2021 through April 30, 2023.
- e. **Resolution** - Accepting the unit price proposal for analytical soil testing fees from Clean Soils Consulting, LLC at the proposed unit prices waste for a period of May 1, 2021 through April 30, 2022.
- f. **Resolution** - Preliminary approval for the purchase, removal and installation of 33 Street Lights by Rag’s Electric, Inc. within the Woodland Subdivision at a cost not to exceed \$71,200.

- g. **Resolution** - Authorizing the Mayor and City Clerk to extend the Roadside Ditch Maintenance contract unit prices between the City of Darien and Scorpio Construction Corporation as it relates to the 67th Street geometrical roadway reconfiguration, 67th Street and Clarendon Hills Road, for the removal and replacement of storm sewer pipes, structures and grading in an amount not to exceed \$40,000.
 - h. **Minutes** – **January 25, 2021** Municipal Services Committee
- 5. Director’s Report**
 - 6. Next scheduled meeting – March 22, 2021**
 - 7. Adjournment**

AGENDA MEMO
Municipal Services
February 22, 2021

ISSUE STATEMENT

Approval of a [resolution](#) to approve the services for a Code Enforcement Officer.

BACKGROUND/HISTORY-UPDATED FOR MUNICIPAL SERVICES FEBRUARY 22, 2021

At the January 25, 2021 Municipal Services Meeting, the Committee requested additional information in respect to Code Enforcement:

The data requested consist of the following:

- *Resume-Karyn Byrne-on file*
- *Survey of Adjacent Municipalities relating to Code Enforcement Hours/Salary- Attached as [Attachment 1-A](#)*

SUMMARY AND FINDINGS

For this study, information was collected from comparable communities pertaining to code enforcement staffing, pay rate, and overall resources put toward enforcement at a local level. The objective of this study is to illustrate other communities' level of code enforcement production versus the City of Darien. The above-mentioned survey/attachment shows pertinent information collected.

Based on the survey data, the City of Darien is the lone community to assign a staff member (City Planner) other than a code officer, building inspector, or consultant, to conduct enforcement activities in a lead role. Among the communities surveyed the City of Darien also has the lowest amount of weekly hours dedicated to code enforcement. In contrast, the Village of Westmont, which has similar population to the City of Darien, has two (2) full time code officers dedicated to enforcement. This amounts to a difference of 65-70 hours a week that are dedicated to enforcement when comparing the two (2) communities.

In addition to the details above, a list of averages has been provided below to show how the City of Darien compares to the group of communities surveyed in terms of code enforcement output:

- *Average population of communities surveyed and for which data was collected – 35,000 (Average) vs. 21,884 (Darien)*
- *Average number of weekly hours dedicated to code enforcement among communities surveyed – 53 Hours (Average) vs. 10-15 Hours (Darien)*
- *Average hourly rate for employees with code enforcement obligations among communities surveyed – \$37.90 Hourly (Average) vs. \$37.46 Hourly (Darien)*

The City of Darien takes great pride in maintaining its aesthetic appearance and promoting involvement of community members and neighborhood organizations in assuring the City remains a healthy and welcoming place to live, work, and visit. The Code Enforcement Operations provides a framework for City Staff to provide code compliance in a manner which is clear and concise for our residents, visitors and businesses. The strategy of the department is now to shift focus to a more proactive versus reactive nature of code compliance. The City currently receives correspondence via email or telephone regarding code violations. The primary point person for code enforcement is the

City Planner. Due to time constraints, Staff does not have the ability to be proactive for code compliance.

Below are essential duties for Code Enforcement;

- Enforces and applies the Zoning and Municipal Codes, limited Building Codes and other related codes and regulations related to community preservation, health, and safety
- Conducts field investigations and site surveillance of residential, commercial, and industrial properties to uncover possible violations of City codes and ordinances
- Issues notices of violation and administrative citations for violations relating to public nuisances including: zoning infractions, building maintenance, accumulation of litter and debris, abandoned vehicles, overgrown weeds, irrigation runoff, and general property neglect
- Photographs evidence, prepares diagrams, takes measurements, interviews potential witnesses, and composes letters and follows up to ensure remedial action has been taken to abate the violation
- Receives complaints from citizens and other sources; issues corrective notices, performs routine follow-up inspections
- Prepares memos and investigative reports; initiates procedures on suspected violations; explains and provides alternative mitigating measures to property owners to resolve violations
- Responds to inquiries from the public regarding code and ordinance requirements, interpretation, policies, and applicability
- Prepares code violation cases for presentation at administrative hearings, and future in house judicial proceedings
- Works collaboratively with the City Attorney to gain compliance on complex issues
- Participates in and coordinates joint inspections of properties with other City departments
- Researches property ownership and zoning, building and parcel histories; interprets building and planning project entitlements

Proposed Goals

To implement the proactive program, the Department is requesting the services of a Code Enforcement Officer. The position would be a part-time position through a consultant. The Officer would perform window observations relating to more common violations such as:

- Debris, rubbish fronting property
- Weeds and grass height violations
- Refuse containers
- Dilapidated fences
- Building facade deficiencies
- Trailers
- Recreational vehicles
- Dead trees, limbs
- Inoperable vehicles
- Leaf and snow disbursement into the roadway

Implementation

- The City would be broken into seven sections and would dovetail with the snow routes
- The Code Enforcement Officer will cover a section per week
- The total hours would be approximately 20 hours
- Respond to complaints as directed by Staff

Engagement

The citizens of the community deserve courteous, prompt, and professional attention to complaints concerning code violations. Violations must be abated quickly, but with due regard to the needs and circumstances of the violator. In this regard, violations must be handled courteously and with sensitivity. The overriding concern is for the safety and needs of the community at large. Deviations from procedures may be considered on a case-by-case basis, utilizing the professional discretion of the Code Enforcement Officer in communication with City Staff. Complaint-generated enforcement goes hand in hand with pro-active enforcement in that the Officer should seek out proactive violations in the surrounding neighborhood when following up on a complaint. This will prevent the image of “selective” enforcement. Proactive cases are handled in the same manner as complaint reference cases, except there will be no response directed to the complainant. Code Enforcement Officers will also handle cases as they are witnessed in the field. For instance if they are responding to a complaint in a section and notice other code violations in the neighborhood they are responding to, the Code Enforcement Officer will provocatively open cases on all violations observed.

Violation Notices

Correspondences Notices of Violation (NOVs) are standard form letters that are sent out for municipal code violations. In general, a first NOV, second NOV and citation letter will be the progression for the majority of our code cases. Below is a general description of these three letters.

Initial NOV-The first NOV is a standard form letter or a door hanger used to open communication and notify property owners and/or tenants of existing conditions on property that appear to be in violation of the code. The initial NOV going to residential properties is sent to the **property owner** as listed on the tax rolls. A copy may also be sent to the resident on-site if the property owner is an absentee owner. For commercial properties, the first letter is sent to the business owner or manager, with a copy of the letter also sent to the property owner. The letter will list and describe in detail conditions that appear to be violations. The letter requests voluntary correction of conditions listed and provides a specific time period for the abatement. Please note the Code Enforcement Officer will always take the initial opportunity to cold call and meet with the occupant of the property regarding the violation.

Second NOV-The second NOV is used to notify the property owner that the conditions mentioned in the first letter have not been corrected. The second NOV requests voluntary compliance and gives a specific timeline for correction of the violation(s). The timeline for correction of each violation may be determined by the officer. Correction time frames are based on how long it would reasonably take to correct the violation, how long they were previously given in the first notice, provisions in the Municipal Code and best practices. Typically Property Maintenance Codes allows violators be given

a minimum of 7 days and a maximum of 30 days to correct a violation.” The letter must issue a warning that if the nuisance is not abated, it will result in an administrative citation.

Citation Letter-If compliance is not gained with the second NOV in the period prescribed by the officer, an administrative citation will be issued. The citation will be accompanied by a letter prescribing the reason for the citation, method of paying for the citation, and means to dispute the citation. The Code Enforcement Officer shall attempt to issue the citation to the responsible party at the site of any violation and obtain the signature of the responsible party, if possible. Failure or refusal of the responsible party to sign the citation shall not affect the validity of the citation. If the responsible party is not located, citations will be mailed to the property owner via both certified and regular mail.

STAFF RECOMMENDATION

Attached and labeled as [Exhibit A](#), is an Independent Contractor Agreement for Code Enforcement Services. The City Staff respectfully requests to enter into an agreement for the code enforcement services of Karyn Byrne. Ms. Byrne has been engaged by Staff throughout the years on more complex cases. She has provided very satisfactory services leading to the abatement of the violation. Ms. Byrne has extensive knowledge of the Property Maintenance Code, general nuisances and consults with various other municipalities.

The services of Ms. Byrne would be curtailed to approximately 20 hours a week at a rate of \$40.00 per hour. Please note, that court appearances are include within the proposed hours. An additional rate of \$50.00 may be utilized for hours between 8:00 pm and 6:00 am Monday - Friday, weekend or holidays.

The proposed expenditure will be introduced at the upcoming Budget Meetings and would be allocated as follows:

ACCOUNT NUMBER	ACCOUNT DESCRIPTION	FY 21-22 BUDGET	PROPOSED EXPENDITURE
01-20-4325	CODE ENFORCEMENT OFFICER	\$ 41,600	\$ 41,600

ALTERNATE CONSIDERATION-UPDATED FOR MUNICIPAL SERVICES FEBRUARY 22, 2021

This item was tabled and redirected to Staff for additional information. The Committee is requested to review and forward a recommendation for City Council consideration.

As directed by the Municipal Services Committee

DECISION MODE

This item will be forwarded to the March 1, 2021 City Council Meeting for formal approval pending Budget consideration.



COMMUNITY SURVEY – CODE ENFORCEMENT DEPARTMENTS/RESOURCES

MUNICIPALITY	POPULATION (2019 EST.)	NO. EMPLOYEES HANDLING CODE ENFORCEMENT (CLASSIFICATION)	WEEKLY STAFFING HOURS DEDICATED TO CODE ENFORCEMENT	MEDIAN HOURS PER WEEK	HOURLY WAGE (\$) FOR STAFF WITH CODE ENFORCEMENT OBLIGATIONS	ANNUAL SALARY WITHOUT BENEFITS	ANNUAL SALARY COST PER POPULATION/RESIDENT
BOLINGBROOK	74,431	6 (FULL TIME & PART TIME SERVICE OFFICERS)	100-150 HOURS	125	\$ 32.94	\$ 214,110.00	\$ 2.88
DARIEN (CURRENT)	21,884	1 (FULL TIME PLANNER)	10-15 HOURS	12.5	\$ 37.46	\$ 24,349.00	\$ 1.11
DOWNERS GROVE	49,470	2 (FULL TIME CODE OFFICERS)	80 HOURS	80	\$ 34.30	\$ 142,688.00	\$ 2.88
HINSDALE	17,637	1 (FULL TIME BUILDING INSPECTOR)	10-15 HOURS	12.5	\$ 43.51	\$ 28,281.50	\$ 1.60
LISLE	23,431	5 (FULL TIME & PART TIME SERVICE OFFICERS)	25-50 HOURS	38.5	\$ 24.28	\$ 48,608.56	\$ 2.07
WESTMONT	24,931	2 (FULL TIME CODE OFFICERS)	80 HOURS	80	\$ 32.82	\$ 136,531.20	\$ 5.48
*WILLOWBROOK	8,673	1 (PART TIME CONSULTANT)	VARIES / AS NEEDED	N/A	\$ 45.00	N/A	N/A
WOODRIDGE	33,455	1 (PART TIME CONSULTANT)	20 HOURS	20	\$ 60.00	\$ 62,400.00	\$ 1.87
*BURR RIDGE (NO RESPONSE)	10,763	--	--	--	--	--	--
*LOMBARD (NO RESPONSE)	43,998	--	--	--	--	--	--
*DARIEN PROPOSED	21,884	CONSULTING CODE ENFORCEMENT OFFICER	20	20	\$ 40.00	\$ 41,600.00	\$ 1.90
*MEDIAN OVERALL	35,034.14			52.64	\$ 37.90	\$ 93,852.61	\$ 2.56
*NOT USED FOR CALCULATION							

RESOLUTION _____

**A RESOLUTION AUTHORIZING THE CITY ADMINISTRATOR TO EXECUTE A
PROFESSIONAL SERVICES AGREEMENT BETWEEN KARYN BYRNE
AND THE CITY OF DARIEN FOR CODE ENFORCEMENT SERVICES**

**BE IT RESOLVED BY THE CITY COUNCIL OF THE CITY OF DARIEN,
DU PAGE COUNTY, ILLINOIS**, that the City Administrator is hereby authorized to execute a
Professional Services Agreement between the City of Darien and Karyn Byrne, a copy of which is
attached hereto as "[Exhibit A](#)", which is by this reference expressly incorporated herein.

**PASSED AND APPROVED BY THE CITY COUNCIL OF THE CITY OF DARIEN,
DU PAGE COUNTY, ILLINOIS**, this 1st day of March 2021.

AYES: _____

NAYS: _____

ABSENT: _____

**APPROVED BY THE MAYOR OF THE CITY OF DARIEN, DU PAGE COUNTY,
ILLINOIS**, this 1st day of March 2021.

JOSEPH MARCHESE, MAYOR

ATTEST:

JOANNE RAGONA, CITY CLERK

APPROVED AS TO FORM:

CITY ATTORNEY



INDEPENDENT CONTRACTOR AGREEMENT FOR
CODE ENFORCEMENT SERVICES

This agreement made as of the 1st day of March, 2021 by and between the City of Darien, DuPage County, Illinois, and Karyn Byrne, for Code Enforcement Services in the City of Darien shall be and is as follows:

WITNESSETH

WHEREAS, KARYN BYRNE has extensive experience in code enforcement of property maintenance, construction site inspections, zoning, and municipal codes; and

WHEREAS the City of Darien is desirous of having its City codes and ordinances enforced; and

NOW, THEREFORE, in consideration of the mutual undertakings and promises contained herein, the parties hereto agree as follows:

There is no employee/employer relationship between KARYN BYRNE and THE CITY OF DARIEN. KARYN BYRNE is an independent contractor and not the City’s employee for all purposes, including, but not limited to, the application of the Fair Labors Standards Act minimum wage and overtime payments, Federal Insurance Contribution Act, the Social Security Act, the Federal Unemployment Tax Act, the Worker’s Compensation Act (820 ILCS 305/1,ET.SEQ.). The CITY OF DARIEN will not (i) provide any form of insurance coverage, including but not limited to health, workmen’s compensation, professional liability insurance, or other employee benefits, or (ii) deduct any taxes or related items from the monies paid to KARYN BYRNE

KARYN BYRNE shall act as an authorized Code Enforcement Representative and shall enforce all violations of local codes and ordinances within the scope of her responsibilities with the CITY OF DARIEN as directed by Director of Municipal Services. If necessary, this may include testifying in court on behalf of the CITY OF DARIEN. KARYN BYRNE shall provide code enforcement administrative assistant services, which will include responding to and managing code enforcement cases, for the CITY OF DARIEN, and other duties at the direction of the Director of Municipal Services. KARYN BYRNE shall work under the direct supervision of and report to the Director of Municipal Services. The performance of the work described herein shall not be construed as creating any joint employment relationship between KARYN BYRNE and the CITY OF DARIEN and the City is not and will not be liable for any obligations incurred by KARYN BYRNE, including but not limited to unpaid minimum wages and/or overtime premiums, nor does there exist an agency relationship or partnership between the CITY OF DARIEN and KARYN BYRNE.

It is acknowledged that at all times KARYN BYRNE is a separate and independent from the CITY OF DARIEN and that KARYN BYRNE has the full opportunity to find other business, and that she has made her owner investment in her business and that she will utilize a high level of skill necessary to perform the work assigned to her.

The CITY OF DARIEN shall pay KARYN BYRNE based on an hourly basis of forty dollars (\$40.00) per hour during normal business hours. Any work that the CITY OF DAIREN shall request or require that occurs on a weekend, holiday or between the hours of 8:00 P.M. and 6:00 A.M. shall be based on an hourly basis of fifty dollars (\$50.00) per hour. The services provided to the CITY OF DARIEN by KARYN BYRNE shall be on an as needed basis at the discretion of the Director of Municipal Services

This agreement shall be effective from _____ and end _____. Notwithstanding any provision contained herein to the contrary, either party may terminate this agreement at any time; however, KARYN BYRNE agrees to give thirty (30) days prior written notice to the CITY OF DARIEN before terminating this agreement.

A detailed Statement for Services Rendered shall be made monthly, and payment by the CITY OF DARIEN for such services shall be made upon receipt of statement. Said statement for Services Rendered shall identify the following:

- A) Specific date and number of hours of inspection services.
- B) Court time specific to each property/complaint

To the fullest extent permitted by law, KARYN BYRNE hereby agrees to defend, indemnify and hold harmless the CITY OF DARIEN, its officials, agents, employees, against all injuries, deaths, loss, damages claims, patent claims, suits, liabilities, judgments, cost and expenses, which may in anywise accrue against the CITY OF DARIEN, its officials, agents and employees, arising in whole or in part or in consequence of the performance of this work by KARYN BYRNE, or which may in anywise result therefore, except that arising out of the sole legal cause of the CITY OF DARIEN, its agents or employees. KARYN BYRNE shall at her own expense, appear, defend and pay all charges of attorneys and all costs and other expenses arising therefore or incurred in connection therewith, and, if any judgment shall be rendered against the CITY OF DARIEN, its officials, agents and employees, in any such action, KARYN BYRNE shall, at her own expense, satisfy and discharge the same.

Dated this ___ day of _____, 2021

City of Darien

BY: _____
Joseph Marchese, Mayor

ATTEST: _____
Jo Anne E. Ragona, City Clerk

BY: _____
Karyn A. Byrne

AGENDA MEMO
Municipal Services Meeting
February 22, 2021

ISSUE STATEMENT

Approval of a [resolution](#) authorizing the Mayor to accept a proposal from Christopher B. Burke Engineering, Ltd. for the professional design services related to the Construction Layout Services for the geometrical reconfiguration of 67th Street-adjacent to the western leg of Clarendon Hills Road in an amount not to exceed \$5,000.

AND

A **motion** authorizing a contingency in the amount of \$2,000 for any additional engineering or construction layout services

BACKGROUND

At the October 7th 2019, City Council Meeting, Staff was directed to begin to implement the below improvements as they relate to the 67th Street Realignment project. Attached, and labeled as [Attachment A](#), is the October 7th, 2019 City Council Agenda.

Below is a summary of work completed and/or scheduled pending the FY21/22 Budget.

1. Trim the trees along the intersection's right-of-way and, if possible, along the private properties adjacent to the intersection. *The Municipal Services Dept. trimmed the trees and will maintain to a turf area.*
2. Relocate the stop bar on the eastbound approach of 67th Street. Cost \$1,000. *The striping is included in the FY21-22 Budget*
3. Install Cross Road (MUTCD W2 -1) warning signs with an advance street name plaque on Clarendon Hills Road. *Completed in 2020*
4. Install Cross Road warning signs on both sides of the road both north and south of the intersection. Cost include within the above item. *The proposed signs are scheduled to be completed in conjunction with the restoration of the realignment.*
5. Install warning beacons on the warning signs. *The Cost for warning beacons is estimated to be approximately \$1,500 and is tentatively scheduled for inclusion with the above revised schedule.*
6. Install speed limits signs and/or radar speed feedback signs on Clarendon Hills Road both north and south of the intersection. Cost \$10,000. *Completed in 2020*
7. Widen the eastbound approach of 67th Street to provide a westbound lane and an eastbound separate left-turn lane and a shared through/right-turn lane. *The realignment is included in the FY21-22 Budget*

The funding for the re-construction is inclusive of the FY21-22 Budget. The scope of work includes reconstructing the west leg of the 67th Street/Clarendon Hills Road intersection to mirror the east leg of the intersection (owned by the Village of Willowbrook). This includes a right turn/thru lane, a striped left turn lane, and a thru lane. This proposal assumes the existing 67th Street pavement from Clarendon Hills Road to the west will be reconstructed with 2" of Hot-Mix Asphalt Surface Course, 4" of Hot-Mix Asphalt Binder Course, and 12" of Aggregate Base Course

will be utilized to widen the roadway to the north of the existing pavement. The improvement length is approximately 400 linear feet.

The 67th Street roadway has been re-scheduled for resurfacing this year and this opportunity allows for a substantial savings in the amount of \$150,000 versus if the project was a standalone project. The estimated construction costs associated with widening have been estimated and are summarized as [Attachment B](#).

Since Staff does not have the expertise to layout the proposed widening, engineering services for construction layout are required. The services include limited site visits for the staking of the storm water infrastructure, curb and gutter as well as road grades. See [Attachment C](#).

ACCOUNT NUMBER	ACCOUNT DESCRIPTION	FY21-22 BUDGET	PROPOSED EXPENDITURE
25-35-4325	Engineering - 67 th Street – Construction Layout	\$5,000	\$5,000

STAFF RECOMMENDATION

Approval of a resolution authorizing the Mayor to accept a proposal from Christopher B. Burke Engineering, Ltd. for the professional engineering services related to the Construction Layout Services for the geometrical reconfiguration of 67th Street-adjacent to the western leg of Clarendon Hills Road in an amount not to exceed \$5,000.

AND

A **motion** authorizing a contingency in the amount of \$2,000 for any additional engineering or construction layout services

ALTERNATE CONSIDERATION

Not approving the resolution.

DECISION MODE

This item will be placed on the March 1, 2021 City Council agenda for formal approval.

AGENDA MEMO

City Council

October 7, 2019

ISSUE STATEMENT

Approval of a resolution authorizing the Mayor to accept a proposal from Christopher B. Burke Engineering, Ltd. for the professional engineering services related to the design and preparation of construction documents for the 67th Street Improvements Project in an amount not to exceed \$32,017.

Please note this agenda memo is being presented due to timing constraints and pending City Council approval of a previous memo addressing 67th and Clarendon Hills Road - traffic signal warrant study and options from Kenig, Lindgren, O'Hara, Aboona, Inc. (KLOA), traffic-engineering consultants, Option 3.

BACKGROUND

Recently, the City Council has been reviewing the 67th Street and Clarendon Hills Road traffic signal warrant study and options as prepared by Kenig, Lindgren, O'Hara, Aboona, Inc. (KLOA), traffic-engineering consultants.

Since the roadway is slated for a resurfacing project, there is an opportunity to construct the suggested geometrical reconfiguration with cost savings. The reasoning is since the city bids and oversees various facets of road construction; curb and gutter, paving and striping, the items would be included as part of our annual contracts. The cost savings would be further realized due to the above-mentioned versus the project being bid as a sole contract.

In anticipation of the approval of the geometrical configuration, referred to as Option No 3, the engineering services would include the reconstruction of the west leg of the 67th Street/Clarendon Hills Road intersection to mirror the east leg of the intersection (owned by the Village of Willowbrook). The scope of work includes the following:

- Widening the western mouth of the intersection
- Constructing a right turn lane
- Constructing a left turn lane, and a thru lane.

The scope of services includes the following:

PHASE I – PRELIMINARY ENGINEERING:

- Task 1 – Project Kick-off Meeting
- Task 2 – Topographic Survey
- Task 3 – Geotechnical Investigation
- Task 4 – Evaluation of Geotechnical Report
- Task 5 – Field Reconnaissance

PHASE II –ENGINEERING DESIGN AND BIDDING:

- Task 6 – J.U.L.I.E. Utility Coordination
- Task 7 – Preparation of Preliminary Concept Plan (50% Submittal)
- Task 8 – Meeting with City

RESOLUTION NO. R-96-19

A RESOLUTION AUTHORIZING THE MAYOR TO ACCEPT A PROPOSAL FROM CHRISTOPHER B. BURKE ENGINEERING, LTD. FOR THE PROFESSIONAL ENGINEERING SERVICES RELATED TO THE DESIGN AND PREPARATION OF CONSTRUCTION DOCUMENTS FOR THE 67TH STREET IMPROVEMENTS PROJECT IN AN AMOUNT NOT TO EXCEED \$32,017

BE IT RESOLVED BY THE CITY COUNCIL OF THE CITY OF DARIEN, DU PAGE COUNTY, ILLINOIS, as follows:

SECTION 1: The City Council of the City of Darien, hereby authorizes the Mayor to accept a proposal from Christopher B. Burke Engineering, Ltd. for the professional engineering services related to the design and preparation of construction documents for the 67th Street improvements project in an amount not to exceed \$32,017., a copy of which is attached hereto as "**Exhibit A**" and is by this reference expressly incorporated hereto.

SECTION 2: This Resolution shall be in full force and effect from and after its passage and approval as provided by law.

PASSED BY THE CITY COUNCIL OF THE CITY OF DARIEN, DU PAGE COUNTY, ILLINOIS, this 7th day of October 2019.

AYES: 7 - Belczak, Chlystek, Gustafson, Kenny, Schuaer, Sullivan, Vaughan

NAYS: 0 - NONE

ABSENT: 0 - NONE

APPROVED BY THE MAYOR OF THE CITY OF DARIEN, DU PAGE COUNTY, ILLINOIS, this 7th day of October 2019.

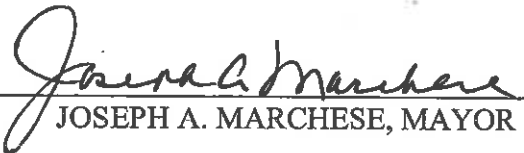
JOSEPH A. MARCHESE, MAYOR

ATTEST:

JOANNE E. RAGONA, CITY CLERK

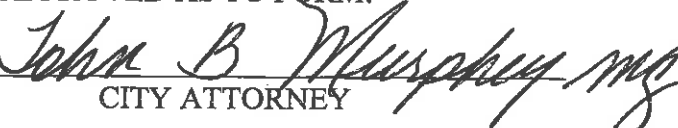
APPROVED AS TO FORM:

CITY ATTORNEY





CHRISTOPHER B. BURKE ENGINEERING, LTD.

9575 West Higgins Road Suite 600 Rosemont, Illinois 60018 TEL (847) 823-0500 FAX (847) 823-0520

September 4, 2019

City of Darien
City Hall
1702 Plainfield Road
Darien, Illinois 60561

Attention: Dan Gombac

Subject: Proposal for Professional Engineering Services
67th Street Improvements Project—Clarendon Hills Road to Alabama Avenue

Dear Dan:

At your request, Christopher B. Burke Engineering, Ltd. (CBBEL) is pleased to provide this proposal for professional engineering services related to the design and preparation of construction documents for the 67th Street Improvements Project. Included below you **will** find our Understanding of the Assignment, Scope of Services, and Estimate of Fee.

UNDERSTANDING OF THE ASSIGNMENT

We understand the City of Darien would like to reconstruct the west leg of the 67th Street/Clarendon Hills Road intersection to mirror the east leg of the intersection (owned by the Village of Willowbrook). This includes a right turn/thru lane, a striped left turn lane, and a thru lane. This proposal assumes the existing 67th Street pavement from Clarendon Hills Road to the west will be reconstructed with 2" of Hot-Mix Asphalt Surface Course, 4" of Hot-Mix Asphalt Binder Course, and 12" of Aggregate Base Course will be utilized to widen the roadway to the north of the existing pavement. The improvement length is approximately 400 linear feet.

CBBEL proposes the following Scope of Services for the 67th Street Improvements Project.

PHASE I – PRELIMINARY ENGINEERING:

Task 1 – Project Kick-off Meeting

CBBEL will meet with City staff to discuss the project goals and objectives and collect all pertinent data. At the kick-off meeting, the Project Team will formalize working relationships, establish primary points of contact and review project procedures. The kick-off meeting will also serve as an opportunity to discuss project constraints and identify anticipated design, permitting and construction issues. CBBEL will prepare meeting notes with action items identified and distribute to the meeting attendees.

Task 2 – Topographic Survey

As part of this task, CBBEL will perform Full Topographic Survey of 67th Street and the adjacent Clarendon Hills Road intersection (500'LF±) to be used as a base map for Design purposes. The following scope items will be included in this task:

Horizontal Control: Utilizing state plane coordinates, CBBEL will set recoverable primary control utilizing state of the art GPS equipment based on NGS Control Monumentation.

Vertical Control: CBBEL will establish benchmarks and assign elevations to the horizontal control points. This will be based on GPS observed NGS Control Monumentation (NAVD'88 vertical control datum).

Existing Right-of-Way: CBBEL will establish the approximate existing right-of-way of the roadways within the project limits based on monumentation found in the field, plats of highways, subdivision plats and any other available information.

Topographic Survey: CBBEL will field locate all pavements, driveways, bike path, curb and gutters, pavement markings, signs, manholes, utility vaults, drainage structures, utilities, driveway culverts, cross road culverts, etc. within the project limits (as per attached exhibit). Field location of all above ground utilities including, but not limited to: water, sanitary sewer, storm sewer, telephone, electric, cable and gas, etc. Identify size, type, rim, and invert elevations.

Cross Sections: CBBEL will survey cross sections along the project limits at 50' intervals, at driveways, and at all other grade controlling features. Survey will be obtained for 10 feet beyond the existing right-of-way line.

Utility Survey and Coordination: All existing storm and sanitary sewers will be surveyed to determine rim and invert elevations and pipe sizes. Above ground facilities of any additional underground utilities including water main, gas, electric, cable, etc. will also be located. No J.U.L.I.E. Utility Survey Coordination is included in this task.

Tree Survey: CBBEL will locate all trees over 6" inches in diameter within the existing right-of-way and ultimately the proposed right-of-way for the project in order to assess potential tree impacts, if any, associated with the project. The located trees will be identified by species (deciduous or coniferous) and the size and condition determined as appropriate.

Base Mapping: CBBEL will compile all of the above information onto base maps at 1"=20' scale that is representative of existing conditions for use as the base sheet for the construction of any public or private improvements.

Task 3 – Geotechnical Investigation

One (1) pavement core will be obtained as part of the Geotechnical Exploration by Testing Services Corporation (TSC) for compliance with the Clean Construction Demolition Debris (CCDD).

The report will give complete pavement and base surface thickness, as well as subgrade description and laboratory test dates. Comments will also be made concerning proposed pavement overlay and/or maintenance.

We recommend that the CCDD/USFO facility destination to be used for a particular project be contacted to verify the analytical parameters proposed will be sufficient.

The objectives of the Study are to determine whether the associated laboratory analysis provide a basis for TSC to sign IEPA Form LPC-663, Unincorporated Soil Certification by a Licensed Professional Engineer.

Uncontaminated soil including uncontaminated soil mixed with clean construction for demolition debris (CCDD) accepted at a CCDD fill operation must be certified to be uncontaminated soil in accordance with Section 22.51(f)(2)(B) of the Environmental Protection Act {415 ILCS 5/22 (f)(2)(B)}. Uncontaminated soil accepted at an uncontaminated soil fill operation (USFO) must be certified to be uncontaminated soil in accordance with Section 22.51a(d)(2)(B) of the Environmental Protection Act {415 ILCS 5/22.51a(d)(2)(B)}. These certifications must be made by a licensed professional engineer or geologists (PE/PG) using the attached Form LPC-663 when the soil is removed from a site which is determined by the PE/PG to be a "Potentially Impacted Property" (PIP) based on review of readily ascertainable property history, environmental databases and site reconnaissance. Uncontaminated soil from a site which is not identified as a PIP by the PE/PG may be certified by either the source site owner or operator using LPC-662 with pH analysis only.

A summary report will be prepared which describes the sampling procedures followed and presents results of the analytical laboratory testing. If all analytical results meet their respective MACs, Form LPC-663 will be filled out and signed by a Licensed Professional Engineer or Geologist. The report will be included.

Task 4 – Evaluation of Geotechnical Report

CBBEL and City Staff will evaluate the geotechnical report to determine any changes to the proposed typical section and project specifications, including any additional pay items that may be required.

Task 5 – Field Reconnaissance: CBBEL Design and Construction Staff will perform a Field Reconnaissance of the pavement to be widened and reconstructed. The purpose of the Field Reconnaissance will be to determine the limits and drainage issues. The results of the Field Reconnaissance will be used to prepare the bid booklet. The results of the Field Reconnaissance will be reviewed with the City Staff and compared to previous estimates to determine the impact on the estimated construction cost.

PHASE II –ENGINEERING DESIGN AND BIDDING:

Task 6 – J.U.L.I.E. Utility Coordination

CBBEL will coordinate with JULIE to retrieve atlas information for all applicable underground utilities including water main, gas, electric, cable, etc. CBBEL will compile all Utility Atlas information into the base map. Locations of existing utilities /obstructions / systems shown on the base map are the compilation of available utility plans provided by utility owners and JULIE Utility Coordination. All utilities /obstructions / systems may not be shown. Contractor shall be responsible for locating and protecting all underground utilities /obstructions / systems whether or not shown on base map. JULIE Utility Coordination Atlas information is typically isolated to Public Right-of-Way & limited areas adjacent to Public Right-of-Way. Identification of all private utilities within project area (on-site) is the responsibility of the client.

Task 7 – Preparation of Preliminary Concept Plan (50% Submittal)

CBBEL will prepare a preliminary concept plan showing the proposed layout of the propose roadway improvements, including widening limits, proposed striping, and drainage improvements, as well as a detailed proposed typical section. A preliminary estimate of cost will also be provided to the City at this time.

Task 8 – Meeting with City

CBBEL will meet on-site with representatives from the City to discuss the project implications as shown on the Preliminary Concept Plan detailed in Task 7. This task assumes one (1) meeting at two (2) hours with two (2) CBBEL employees and the preparation of meeting minutes.

At this time, the City will determine if they want to proceed with the project.

DESIGN ENGINEERING PHASE:

Task 9 – Preliminary Contract Documents and Cost Estimate (95% Submittal)

CBBEL will prepare plans, specifications, and cost and working day estimates in accordance with all applicable City, IDOT, Illinois Sewer and Water Standards and other agency standards. Plans will be prepared using MicroStation CAD software.

CBBEL will use IDOT standard pay items or City standard special provisions where applicable. Otherwise, project-specific special provisions will be written as needed. Plans, specifications and estimates will be submitted to the City for review.

Detailed plans will be developed and are anticipated to consist the following:

SHEET	# OF SHEETS	HOURS PER SHEET	HOURS
Title Sheet	1	8	8
General Notes	1	8	8
Summary of Quantities	1	12	12
Earthwork Schedule	1	12	12
Alignment, Ties and Benchmarks	1	8	8
Typical Section	1	12	12
Existing Conditions and Removal Plan (1" = 20')	1	10	10
Roadway Plan and Profile (1" = 20')	1	12	12
Drainage Plan and Profile (1" = 20')	1	10	10
Proposed Striping Plan (1" = 20')	1	10	10
Soil Erosion/Sediment Control Plan	1	10	10
Construction Details	1	8	8
Soil Erosion/Sediment Control Notes and Details	1	8	8
Cross Sections	2	8	16
Specification	--	--	8
Cost Estimate/Quantities	--	--	8
TOTAL	15		160

Task 10 – QA/QC Submittal and Final Plans, Specifications and Cost Estimate (100% Submittal)

CBBEL will make the final revisions to the 95% submittal based on the review comments from the City and permitting agencies. The City will perform a QA/QC review and CBBEL will then finalize the documents for bidding. The requested number of copies of plans and specifications will be submitted to the City. A final estimate of cost will be provided to the City. CBBEL will provide plans and specifications to the City in the requested hard copy and electronic format.

Task 11 – Bidding Assistance

CBBEL will advertise for bidding, distribute plans and specifications to all bidders, and hold a bid opening. CBBEL will review and tabulate all of the bids and make a recommendation of award.

ESTIMATE OF FEE

CBBEL estimates the following fees for each of the tasks described above:

Task 1 – Project Kick-off Meeting	\$	500
Task 2 – Topographic Survey	\$	4,500
Task 3 – Geotechnical Investigation	\$	3,667
Task 4 – Evaluation of Geotechnical Report	\$	500
Task 5 – Field Reconnaissance	\$	800
Task 6 – J.U.L.I.E. Utility Coordination	\$	500
Task 7 – Preparation of Preliminary Concept Plan (50% Submittal)	\$	10,000
Task 8 – Meeting with City	\$	800
Task 9 – Preliminary Contract Documents and Cost Estimate (95% Submittal)	\$	9,000
Task 10 – QA/QC Submittal and Final Plans, Specifications and Cost Estimate (100% Submittal)	\$	1,000
Task 11 – Bidding Assistance	\$	750
Total	\$	32,017

Tasks 1-8 will be completed for a fee not to exceed \$21,267 within 6 to 8 weeks of receiving notice to proceed. We will not proceed with Tasks 9-11 until directed to do so, and those tasks will take additional 4 to 6 weeks.

We will bill you at the hourly rates specified on the attached Schedule of Charges and General Terms and Conditions. Direct costs for blueprints, photocopying, mailing, overnight delivery, messenger services and report compilation are not included in the Estimate of Fee. These General Terms and Conditions are expressly incorporated into and are an integral part of this contract for professional services. It should be emphasized that any requested additional services that are not included in the preceding Estimate of Fee will be billed at the attached hourly rates.

Please sign and return one copy of this agreement as an indication of acceptance and notice to proceed. Please feel free to contact us anytime.

Sincerely,



Christopher B. Burke, PhD, PE, D.WRE, Dist.M.ASCE
President

Encl. Schedule of Charges
General Terms and Conditions

THIS PROPOSAL, SCHEDULE OF CHARGES AND GENERAL TERMS AND
CONDITIONS ACCEPTED FOR THE CITY OF DARIEN.

BY:



TITLE:

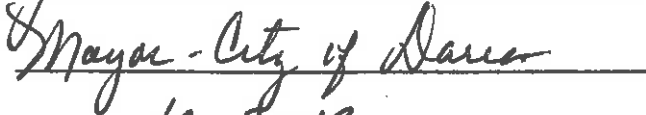

DATE:

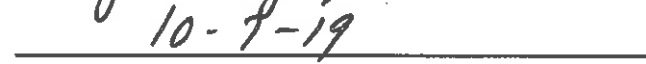

CHRISTOPHER B. BURKE ENGINEERING, LTD.
STANDARD CHARGES FOR PROFESSIONAL SERVICES
JANUARY, 2019

<u>Personnel</u>	<u>Charges*</u> <u>(\$/Hr)</u>
Principal	265
Engineer VI	241
Engineer V	200
Engineer IV	163
Engineer III	146
Engineer I/II	116
Survey V	220
Survey IV	188
Survey III	165
Survey II	121
Survey I	96
Engineering Technician V	190
Engineering Technician IV	155
Engineering Technician III	140
Engineering Technician I/II	65
CAD Manager	170
Assistant CAD Manager	147
CAD II	130
GIS Specialist III	142
GIS Specialist I/II	90
Landscape Architect	163
Environmental Resource Specialist V	208
Environmental Resource Specialist IV	163
Environmental Resource Specialist III	134
Environmental Resource Specialist I/II	90
Environmental Resource Technician	110
Administrative	100
Engineering Intern	61
Information Technician III	125
Information Technician I/II	112

Direct Costs

Outside Copies, Blueprints, Messenger, Delivery Services, Mileage Cost + 12%

*Charges include overhead and profit

Christopher B. Burke Engineering, Ltd. reserves the right to increase these rates and costs by 5% after December 31, 2019.

**CHRISTOPHER B. BURKE ENGINEERING, LTD.
GENERAL TERMS AND CONDITIONS**

1. **Relationship Between Engineer and Client:** Christopher B. Burke Engineering, Ltd. (Engineer) shall serve as Client's professional engineer consultant in those phases of the Project to which this Agreement applies. This relationship is that of a buyer and seller of professional services and as such the Engineer is an independent contractor in the performance of this Agreement and it is understood that the parties have not entered into any joint venture or partnership with the other. The Engineer shall not be considered to be the agent of the Client. Nothing contained in this Agreement shall create a contractual relationship with a cause of action in favor of a third party against either the Client or Engineer.

Furthermore, causes of action between the parties to this Agreement pertaining to acts of failures to act shall be deemed to have accrued and the applicable statute of limitations shall commence to run not later than the date of substantial completion.

2. **Responsibility of the Engineer:** Engineer will strive to perform services under this Agreement in accordance with generally accepted and currently recognized engineering practices and principles, and in a manner consistent with that level of care and skill ordinarily exercised by members of the profession currently practicing in the same locality under similar conditions. No other representation, express or implied, and no warranty or guarantee is included or intended in this Agreement, or in any report, opinion, document, or otherwise.

Notwithstanding anything to the contrary which may be contained in this Agreement or any other material incorporated herein by reference, or in any Agreement between the Client and any other party concerning the Project, the Engineer shall not have control or be in charge of and shall not be responsible for the means, methods, techniques, sequences or procedures of construction, or the safety, safety precautions or programs of the Client, the construction contractor, other contractors or subcontractors performing any of the work or providing any of the services on the Project. Nor shall the Engineer be responsible for the acts or omissions of the Client, or for the failure of the Client, any architect, engineer, consultant, contractor or subcontractor to carry out their respective responsibilities in accordance with the Project documents, this Agreement or any other agreement concerning the Project. Any provision which purports to amend this provision shall be without effect unless it contains a reference that the content of this condition is expressly amended for the purposes described in such amendment and is signed by the Engineer.

3. **Changes:** Client reserves the right by written change order or amendment to make changes in requirements, amount of work, or engineering time schedule adjustments, and Engineer and Client shall negotiate appropriate adjustments acceptable to both parties to accommodate any changes, if commercially possible.
4. **Suspension of Services:** Client may, at any time, by written order to Engineer (Suspension of Services Order) require Engineer to stop all, or any part, of the services required by this Agreement. Upon receipt of such an order, Engineer shall immediately comply with its terms and take all reasonable steps to minimize the costs associated with the services affected by such order. Client, however, shall pay all costs incurred by the suspension, including all costs necessary to maintain continuity and for the

resumptions of the services upon expiration of the Suspension of Services Order. Engineer will not be obligated to provide the same personnel employed prior to suspension, when the services are resumed, in the event that the period of suspension is greater than thirty (30) days.

5. **Termination:** This Agreement may be terminated by either party upon thirty (30) days written notice in the event of substantial failure by the other party to perform in accordance with the terms hereof through no fault of the terminating party. This Agreement may be terminated by Client, under the same terms, whenever Client shall determine that termination is in its best interests. Cost of termination, including salaries, overhead and fee, incurred by Engineer either before or after the termination date shall be reimbursed by Client.
6. **Documents Delivered to Client:** Drawings, specifications, reports, and any other Project Documents prepared by Engineer in connection with any or all of the services furnished hereunder shall be delivered to the Client for the use of the Client. Engineer shall have the right to retain originals of all Project Documents and drawings for its files. Furthermore, it is understood and agreed that the Project Documents such as, but not limited to reports, calculations, drawings, and specifications prepared for the Project, whether in hard copy or machine readable form, are instruments of professional service intended for one-time use in the construction of this Project. These Project Documents are and shall remain the property of the Engineer. The Client may retain copies, including copies stored on magnetic tape or disk, for information and reference in connection with the occupancy and use of the Project.

When and if record drawings are to be provided by the Engineer, Client understands that information used in the preparation of record drawings is provided by others and Engineer is not responsible for accuracy, completeness, nor sufficiency of such information. Client also understands that the level of detail illustrated by record drawings will generally be the same as the level of detail illustrated by the design drawing used for project construction. If additional detail is requested by the Client to be included on the record drawings, then the Client understands and agrees that the Engineer will be due additional compensation for additional services.

It is also understood and agreed that because of the possibility that information and data delivered in machine readable form may be altered, whether inadvertently or otherwise, the Engineer reserves the right to retain the original tapes/disks and to remove from copies provided to the Client all identification reflecting the involvement of the Engineer in their preparation. The Engineer also reserves the right to retain hard copy originals of all Project Documentation delivered to the Client in machine readable form, which originals shall be referred to and shall govern in the event of any inconsistency between the two.

The Client understands that the automated conversion of information and data from the system and format used by the Engineer to an alternate system or format cannot be accomplished without the introduction of inaccuracies, anomalies, and errors. In the event Project Documentation provided to the Client in machine readable form is so converted, the Client agrees to assume all risks associated therewith and, to the fullest

extent permitted by law, to hold harmless and indemnify the Engineer from and against all claims, liabilities, losses, damages, and costs, including but not limited to attorney's fees, arising therefrom or in connection therewith.

The Client recognizes that changes or modifications to the Engineer's instruments of professional service introduced by anyone other than the Engineer may result in adverse consequences which the Engineer can neither predict nor control. Therefore, and in consideration of the Engineer's agreement to deliver its instruments of professional service in machine readable form, the Client agrees, to the fullest extent permitted by law, to hold harmless and indemnify the Engineer from and against all claims, liabilities, losses, damages, and costs, including but not limited to attorney's fees, arising out of or in any way connected with the modification, misinterpretation, misuse, or reuse by others of the machine readable information and data provided by the Engineer under this Agreement. The foregoing indemnification applies, without limitation, to any use of the Project Documentation on other projects, for additions to this Project, or for completion of this Project by others, excepting only such use as may be authorized, in writing, by the Engineer.

7. **Reuse of Documents:** All Project Documents including but not limited to reports, opinions of probable costs, drawings and specifications furnished by Engineer pursuant to this Agreement are intended for use on the Project only. They cannot be used by Client or others on extensions of the Project or any other project. Any reuse, without specific written verification or adaptation by Engineer, shall be at Client's sole risk, and Client shall indemnify and hold harmless Engineer from all claims, damages, losses, and expenses including attorney's fees arising out of or resulting therefrom.

The Engineer shall have the right to include representations of the design of the Project, including photographs of the exterior and interior, among the Engineer's promotional and professional materials. The Engineer's materials shall not include the Client's confidential and proprietary information if the Client has previously advised the Engineer in writing of the specific information considered by the Client to be confidential and proprietary.

8. **Standard of Practice:** The Engineer will strive to conduct services under this agreement in a manner consistent with that level of care and skill ordinarily exercised by members of the profession currently practicing in the same locality under similar conditions as of the date of this Agreement.
9. **Compliance With Laws:** The Engineer will strive to exercise usual and customary professional care in his/her efforts to comply with those laws, codes, ordinance and regulations which are in effect as of the date of this Agreement.

With specific respect to prescribed requirements of the Americans with Disabilities Act of 1990 or certified state or local accessibility regulations (ADA), Client understands ADA is a civil rights legislation and that interpretation of ADA is a legal issue and not a design issue and, accordingly, retention of legal counsel (by Client) for purposes of interpretation is advisable. As such and with respect to ADA, Client agrees to waive any action against Engineer, and to indemnify and defend Engineer against any claim arising from Engineer's alleged failure to meet ADA requirements prescribed.

Further to the law and code compliance, the Client understands that the Engineer will strive to provide designs in accordance with the prevailing Standards of Practice as previously set forth, but that the Engineer does not warrant that any reviewing agency having jurisdiction will not for its own purposes comment, request changes and/or additions to such designs. In the event such design requests are made by a reviewing agency, but which do not exist in the form of a written regulation, ordinance or other similar document as published by the reviewing agency, then such design changes (at substantial variance from the intended design developed by the Engineer), if effected and incorporated into the project documents by the Engineer, shall be considered as Supplementary Task(s) to the Engineer's Scope of Service and compensated for accordingly.

10. **Indemnification:** Engineer shall indemnify and hold harmless Client up to the amount of this contract fee (for services) from loss or expense, including reasonable attorney's fees for claims for personal injury (including death) or property damage to the extent caused by the sole negligent act, error or omission of Engineer.

Client shall indemnify and hold harmless Engineer under this Agreement, from loss or expense, including reasonable attorney's fees, for claims for personal injuries (including death) or property damage arising out of the sole negligent act, error omission of Client.

In the event of joint or concurrent negligence of Engineer and Client, each shall bear that portion of the loss or expense that its share of the joint or concurrent negligence bears to the total negligence (including that of third parties), which caused the personal injury or property damage.

Engineer shall not be liable for special, incidental or consequential damages, including, but not limited to loss of profits, revenue, use of capital, claims of customers, cost of purchased or replacement power, or for any other loss of any nature, whether based on contract, tort, negligence, strict liability or otherwise, by reasons of the services rendered under this Agreement.

11. **Opinions of Probable Cost:** Since Engineer has no control over the cost of labor, materials or equipment, or over the Contractor(s) method of determining process, or over competitive bidding or market conditions, his/her opinions of probable Project Construction Cost provided for herein are to be made on the basis of his/her experience and qualifications and represent his/her judgement as a design professional familiar with the construction industry, but Engineer cannot and does not guarantee that proposal, bids or the Construction Cost will not vary from opinions of probable construction cost prepared by him/her. If prior to the Bidding or Negotiating Phase, Client wishes greater accuracy as to the Construction Cost, the Client shall employ an independent cost estimator Consultant for the purpose of obtaining a second construction cost opinion independent from Engineer.
12. **Governing Law & Dispute Resolutions:** This Agreement shall be governed by and construed in accordance with Articles previously set forth by (Item 9 of) this Agreement, together with the laws of the State of Illinois.

Any claim, dispute or other matter in question arising out of or related to this Agreement, which can not be mutually resolved by the parties of this Agreement, shall be subject to mediation as a condition precedent to arbitration (if arbitration is agreed upon by the parties of this Agreement) or the institution of legal or equitable proceedings by either party. If such matter relates to or is the subject of a lien arising out of the Engineer's services, the Engineer may proceed in accordance with applicable law to comply with the lien notice or filing deadlines prior to resolution of the matter by mediation or by arbitration.

The Client and Engineer shall endeavor to resolve claims, disputes and other matters in question between them by mediation which, unless the parties mutually agree otherwise, shall be in accordance with the Construction Industry Mediation Rules of the American Arbitration Association currently in effect. Requests for mediation shall be filed in writing with the other party to this Agreement and with the American Arbitration Association. The request may be made concurrently with the filing of a demand for arbitration but, in such event, mediation shall proceed in advance of arbitration or legal or equitable proceedings, which shall be stayed pending mediation for a period of 60 days from the date of filing, unless stayed for a longer period by agreement of the parties or court order.

The parties shall share the mediator's fee and any filing fees equally. The mediation shall be held in the place where the Project is located, unless another location is mutually agreed upon. Agreements reached in mediation shall be enforceable as settlement agreements in any court having jurisdiction thereof.

13. **Successors and Assigns:** The terms of this Agreement shall be binding upon and inure to the benefit of the parties and their respective successors and assigns: provided, however, that neither party shall assign this Agreement in whole or in part without the prior written approval of the other.
14. **Waiver of Contract Breach:** The waiver of one party of any breach of this Agreement or the failure of one party to enforce at any time, or for any period of time, any of the provisions hereof, shall be limited to the particular instance, shall not operate or be deemed to waive any future breaches of this Agreement and shall not be construed to be a waiver of any provision, except for the particular instance.
15. **Entire Understanding of Agreement:** This Agreement represents and incorporates the entire understanding of the parties hereto, and each party acknowledges that there are no warranties, representations, covenants or understandings of any kind, matter or description whatsoever, made by either party to the other except as expressly set forth herein. Client and the Engineer hereby agree that any purchase orders, invoices, confirmations, acknowledgments or other similar documents executed or delivered with respect to the subject matter hereof that conflict with the terms of the Agreement shall be null, void & without effect to the extent they conflict with the terms of this Agreement.
16. **Amendment:** This Agreement shall not be subject to amendment unless another instrument is duly executed by duly authorized representatives of each of the parties and entitled "Amendment of Agreement".

17. **Severability of Invalid Provisions:** If any provision of the Agreement shall be held to contravene or to be invalid under the laws of any particular state, county or jurisdiction where used, such contravention shall not invalidate the entire Agreement, but it shall be construed as if not containing the particular provisions held to be invalid in the particular state, country or jurisdiction and the rights or obligations of the parties hereto shall be construed and enforced accordingly.
18. **Force Majeure:** Neither Client nor Engineer shall be liable for any fault or delay caused by any contingency beyond their control including but not limited to acts of God, wars, strikes, walkouts, fires, natural calamities, or demands or requirements of governmental agencies.
19. **Subcontracts:** Engineer may subcontract portions of the work, but each subcontractor must be approved by Client in writing.
20. **Access and Permits:** Client shall arrange for Engineer to enter upon public and private property and obtain all necessary approvals and permits required from all governmental authorities having jurisdiction over the Project. Client shall pay costs (including Engineer's employee salaries, overhead and fee) incident to any effort by Engineer toward assisting Client in such access, permits or approvals, if Engineer perform such services.
21. **Designation of Authorized Representative:** Each party (to this Agreement) shall designate one or more persons to act with authority in its behalf in respect to appropriate aspects of the Project. The persons designated shall review and respond promptly to all communications received from the other party.
22. **Notices:** Any notice or designation required to be given to either party hereto shall be in writing, and unless receipt of such notice is expressly required by the terms hereof shall be deemed to be effectively served when deposited in the mail with sufficient first class postage affixed, and addressed to the party to whom such notice is directed at such party's place of business or such other address as either party shall hereafter furnish to the other party by written notice as herein provided.
23. **Limit of Liability:** The Client and the Engineer have discussed the risks, rewards, and benefits of the project and the Engineer's total fee for services. In recognition of the relative risks and benefits of the Project to both the Client and the Engineer, the risks have been allocated such that the Client agrees that to the fullest extent permitted by law, the Engineer's total aggregate liability to the Client for any and all injuries, claims, costs, losses, expenses, damages of any nature whatsoever or claim expenses arising out of this Agreement from any cause or causes, including attorney's fees and costs, and expert witness fees and costs, shall not exceed the total Engineer's fee for professional engineering services rendered on this project as made part of this Agreement. Such causes included but are not limited to the Engineer's negligence, errors, omissions, strict liability or breach of contract. It is intended that this limitation apply to any and all liability or cause of action however alleged or arising, unless otherwise prohibited by law.

24. **Client's Responsibilities:** The Client agrees to provide full information regarding requirements for and about the Project, including a program which shall set forth the Client's objectives, schedule, constraints, criteria, special equipment, systems and site requirements.

The Client agrees to furnish and pay for all legal, accounting and insurance counseling services as may be necessary at any time for the Project, including auditing services which the Client may require to verify the Contractor's Application for Payment or to ascertain how or for what purpose the Contractor has used the money paid by or on behalf of the Client.

The Client agrees to require the Contractor, to the fullest extent permitted by law, to indemnify, hold harmless, and defend the Engineer, its consultants, and the employees and agents of any of them from and against any and all claims, suits, demands, liabilities, losses, damages, and costs ("Losses"), including but not limited to costs of defense, arising in whole or in part out of the negligence of the Contractor, its subcontractors, the officers, employees, agents, and subcontractors of any of them, or anyone for whose acts any of them may be liable, regardless of whether or not such Losses are caused in part by a party indemnified hereunder. Specifically excluded from the foregoing are Losses arising out of the preparation or approval of maps, drawings, opinions, reports, surveys, change orders, designs, or specifications, and the giving of or failure to give directions by the Engineer, its consultants, and the agents and employees of any of them, provided such giving or failure to give is the primary cause of Loss. The Client also agrees to require the Contractor to provide to the Engineer the required certificate of insurance.

The Client further agrees to require the Contractor to name the Engineer, its agents and consultants as additional insureds on the Contractor's policy or policies of comprehensive or commercial general liability insurance. Such insurance shall include products and completed operations and contractual liability coverages, shall be primary and noncontributing with any insurance maintained by the Engineer or its agents and consultants, and shall provide that the Engineer be given thirty days, unqualified written notice prior to any cancellation thereof.

In the event the foregoing requirements, or any of them, are not established by the Client and met by the Contractor, the Client agrees to indemnify and hold harmless the Engineer, its employees, agents, and consultants from and against any and all Losses which would have been indemnified and insured against by the Contractor, but were not.

When Contract Documents prepared under the Scope of Services of this contract require insurance(s) to be provided, obtained and/or otherwise maintained by the Contractor, the Client agrees to be wholly responsible for setting forth any and all such insurance requirements. Furthermore, any document provided for Client review by the Engineer under this Contract related to such insurance(s) shall be considered as sample insurance requirements and not the recommendation of the Engineer. Client agrees to have their own risk management department review any and all insurance requirements for adequacy and to determine specific types of insurance(s) required for the project. Client further agrees that decisions concerning types and amounts of insurance are

specific to the project and shall be the product of the Client. As such, any and all insurance requirements made part of Contract Documents prepared by the Engineer are not to be considered the Engineer's recommendation, and the Client shall make the final decision regarding insurance requirements.

25. Information Provided by Others: The Engineer shall indicate to the Client the information needed for rendering of the services of this Agreement. The Client shall provide to the Engineer such information as is available to the Client and the Client's consultants and contractors, and the Engineer shall be entitled to rely upon the accuracy and completeness thereof. The Client recognizes that it is impossible for the Engineer to assure the accuracy, completeness and sufficiency of such information, either because it is impossible to verify, or because of errors or omissions which may have occurred in assembling the information the Client is providing. Accordingly, the Client agrees, to the fullest extent permitted by law, to indemnify and hold the Engineer and the Engineer's subconsultants harmless from any claim, liability or cost (including reasonable attorneys' fees and cost of defense) for injury or loss arising or allegedly arising from errors, omissions or inaccuracies in documents or other information provided by the Client to the Engineer.

26. Payment: Client shall be invoiced once each month for work performed during the preceding period. Client agrees to pay each invoice within thirty (30) days of its receipt. The client further agrees to pay interest on all amounts invoiced and not paid or objected to for valid cause within said thirty (30) day period at the rate of eighteen (18) percent per annum (or the maximum interest rate permitted under applicable law, whichever is the lesser) until paid. Client further agrees to pay Engineer's cost of collection of all amounts due and unpaid after sixty (60) days, including court costs and reasonable attorney's fees, as well as costs attributed to suspension of services accordingly and as follows:

Collection Costs. In the event legal action is necessary to enforce the payment provisions of this Agreement, the Engineer shall be entitled to collect from the Client any judgement or settlement sums due, reasonable attorneys' fees, court costs and expenses incurred by the Engineer in connection therewith and, in addition, the reasonable value of the Engineer's time and expenses spent in connection with such collection action, computed at the Engineer's prevailing fee schedule and expense policies.

Suspension of Services. If the Client fails to make payments when due or otherwise is in breach of this Agreement, the Engineer may suspend performance of services upon five (5) calendar days' notice to the Client. The Engineer shall have no liability whatsoever to the Client for any costs or damages as a result of such suspension caused by any breach of this Agreement by the Client. Client will reimburse Engineer for all associated costs as previously set forth in (Item 4 of) this Agreement.

27. When construction observation tasks are part of the service to be performed by the Engineer under this Agreement, the Client will include the following clause in the construction contract documents and Client agrees not to modify or delete it:

Kotecki Waiver. Contractor (and any subcontractor into whose subcontract this clause is incorporated) agrees to assume the entire liability for all personal injury claims suffered by its own employees, including without limitation claims under the Illinois Structural Work Act, asserted by persons allegedly injured on the Project; waives any limitation of liability defense based upon the Worker's Compensation Act, court interpretations of said Act or otherwise; and to the fullest extent permitted by law, agrees to indemnify and hold harmless and defend Owner and Engineer and their agents, employees and consultants (the "Indemnitees") from and against all such loss, expense, damage or injury, including reasonable attorneys' fees, that the Indemnitees may sustain as a result of such claims, except to the extent that Illinois law prohibits indemnity for the Indemnitees' own negligence. The Owner and Engineer are designated and recognized as explicit third party beneficiaries of the Kotecki Waiver within the general contract and all subcontracts entered into in furtherance of the general contract.

28. **Job Site Safety/Supervision & Construction Observation:** The Engineer shall neither have control over or charge of, nor be responsible for, the construction means, methods, techniques, sequences of procedures, or for safety precautions and programs in connection with the Work since they are solely the Contractor's rights and responsibilities. The Client agrees that the Contractor shall supervise and direct the work efficiently with his/her best skill and attention; and that the Contractor shall be solely responsible for the means, methods, techniques, sequences and procedures of construction and safety at the job site. The Client agrees and warrants that this intent shall be carried out in the Client's contract with the Contractor. The Client further agrees that the Contractor shall be responsible for initiating, maintaining and supervising all safety precautions and programs in connection with the work; and that the Contractor shall take all necessary precautions for the safety of, and shall provide the necessary protection to prevent damage, injury or loss to all employees on the subject site and all other persons who may be affected thereby. The Engineer shall have no authority to stop the work of the Contractor or the work of any subcontractor on the project.

When construction observation services are included in the Scope of Services, the Engineer shall visit the site at intervals appropriate to the stage of the Contractor's operation, or as otherwise agreed to by the Client and the Engineer to: 1) become generally familiar with and to keep the Client informed about the progress and quality of the Work; 2) to strive to bring to the Client's attention defects and deficiencies in the Work and; 3) to determine in general if the Work is being performed in a manner indicating that the Work, when fully completed, will be in accordance with the Contract Documents. However, the Engineer shall not be required to make exhaustive or continuous on-site inspections to check the quality or quantity of the Work. If the Client desires more extensive project observation, the Client shall request that such services be provided by the Engineer as Additional and Supplemental Construction Observation Services in accordance with the terms of this Agreement.

The Engineer shall not be responsible for any acts or omissions of the Contractor, subcontractor, any entity performing any portions of the Work, or any agents or employees of any of them. The Engineer does not guarantee the performance of the

Contractor and shall not be responsible for the Contractor's failure to perform its Work in accordance with the Contract Documents or any applicable laws, codes, rules or regulations.

When municipal review services are included in the Scope of Services, the Engineer (acting on behalf of the municipality), when acting in good faith in the discharge of its duties, shall not thereby render itself liable personally and is, to the maximum extent permitted by law, relieved from all liability for any damage that may accrue to persons or property by reason of any act or omission in the discharge of its duties. Any suit brought against the Engineer which involve the acts or omissions performed by it in the enforcement of any provisions of the Client's rules, regulation and/or ordinance shall be defended by the Client until final termination of the proceedings. The Engineer shall be entitled to all defenses and municipal immunities that are, or would be, available to the Client.

29. Insurance and Indemnification: The Engineer and the Client understand and agree that the Client will contractually require the Contractor to defend and indemnify the Engineer and/or any subconsultants from any claims arising from the Work. The Engineer and the Client further understand and agree that the Client will contractually require the Contractor to procure commercial general liability insurance naming the Engineer as an additional named insured with respect to the work. The Contractor shall provide to the Client certificates of insurance evidencing that the contractually required insurance coverage has been procured. However, the Contractor's failure to provide the Client with the requisite certificates of insurance shall not constitute a waiver of this provision by the Engineer.

The Client and Engineer waive all rights against each other and against the Contractor and consultants, agents and employees of each of them for damages to the extent covered by property insurance during construction. The Client and Engineer each shall require similar waivers from the Contractor, consultants, agents and persons or entities awarded separate contracts administered under the Client's own forces.

30. Hazardous Materials/Pollutants: Unless otherwise provided by this Agreement, the Engineer and Engineer's consultants shall have no responsibility for the discovery, presence, handling, removal or disposal of or exposure of persons to hazardous materials/pollutants in any form at the Project site, including but not limited to mold/mildew, asbestos, asbestos products, polychlorinated biphenyl (PCB) or other toxic/hazardous/pollutant type substances.

Furthermore, Client understands that the presence of mold/mildew and the like are results of prolonged or repeated exposure to moisture and the lack of corrective action. Client also understands that corrective action is a operation, maintenance and repair activity for which the Engineer is not responsible.

STATE OF ILLINOIS)
) SS
COUNTY OF DU PAGE)

I, JoAnne E. Ragona, do hereby certify that I am the duly qualified CITY CLERK
of the CITY OF DARIEN of DuPage County, Illinois, and as such officer I am the keeper
of the records and files of the City;

I do further certify that the foregoing constitutes a full, true and correct copy of
**RESOLUTION NO. R-96-19 — *“A RESOLUTION AUTHORIZING THE MAYOR
TO ACCEPT A PROPOSAL FROM CHRISTOPHER B. BURKE ENGINEERING,
LTD. FOR THE PROFESSIONAL ENGINEERING SERVICES RELATED TO THE
DESIGN AND PREPARATION OF CONSTRUCTION DOCUMENTS FOR THE
67TH STREET IMPROVEMENTS PROJECT IN AN AMOUNT NOT TO EXCEED
\$32,017.00”*** of the City of Darien, Du Page County, Illinois, Duly Passed and Approved
by the Mayor and City Council at a Meeting Held on October 7, 2019

IN WITNESS WHEREOF, I have hereunto affixed my official hand and seal
this 7th day of October, 2019.



City Clerk

ITEM	UNIT	QUANTITY	BID PRICING	TOTAL COST
ROADWAY PAVING AND STRIPING				
EARTH EXCAVATION	CU YD	255	\$ 30.00	\$7,650.00
REMOVAL AND DISPOSAL OF UNSUITABLE MATERIAL	CU YD	250	\$ 30.00	\$7,500.00
FURNISHED EXCAVATION	CU YD	100	\$ 20.00	\$2,000.00
AGGREGATE SUBGRADE IMPROVEMENT	CU YD	250	\$ 30.00	\$7,500.00
BITUMINOUS MATERIALS (TACK COAT)	POUND	125	\$ 0.10	\$12.50
POLYMERIZED LEVELING BINDER (MACHINE METHOD), N50	TON	90	\$ 84.00	\$7,560.00
HOT-MIX ASPHALT SURFACE COURSE, MIX "D", N50	TON	215	\$ 64.00	\$13,760.00
HOT-MIX ASPHALT BINDER COURSE, IL-19.0, N50	TON	125	\$ 72.00	\$9,000.00
HOT-MIX ASPHALT SURFACE REMOVAL, 2.5"	SQ YD	1,100	\$ 2.88	\$3,168.00
CLASS D PATCHES, TYPE I, 6 INCH	SQ YD	700	\$ 30.00	\$21,000.00
CLASS D PATCHES, TYPE II, 6 INCH	SQ YD	240	\$ 30.00	\$7,200.00
CLASS D PATCHES, TYPE III, 6 INCH	SQ YD	120	\$ 30.00	\$3,600.00
CLASS D PATCHES, TYPE IV, 6 INCH	SQ YD	120	\$ 30.00	\$3,600.00
THERMOPLASTIC PAVEMENT MARKING - LETTERS AND SYMBOLS	SQ FT	40	\$ 5.25	\$210.00
THERMOPLASTIC PAVEMENT MARKING - LINE 4"	FOOT	815	\$ 0.81	\$660.15
THERMOPLASTIC PAVEMENT MARKING - LINE 6"	FOOT	140	\$ 1.31	\$183.40
THERMOPLASTIC PAVEMENT MARKING - LINE 12"	FOOT	60	\$ 2.62	\$157.20
THERMOPLASTIC PAVEMENT MARKING - LINE 24"	FOOT	30	\$ 5.25	\$157.50
STRUCTURES TO BE ADJUSTED	EACH	4	475	\$1,900.00
TOTAL ROAD WORK VALUE				\$96,818.75
CONCRETE RESTORATION				
PORTLAND CEMENT CONCRETE SIDEWALK 5 INCH	SQ FT	90	\$6.35	\$571.50
COMBINATION CONCRETE CURB AND GUTTER, SPECIAL	FOOT	975	\$23.00	\$22,425.00
TOTAL CONCRETE VALUE				\$22,996.50
LANDSCAPE RESTORATION				
TOPSOIL, FURNISH AND PLACE 6"	SQ YD	1,000	\$8.00	\$8,000.00
GRADING AND SHAPING DITCHES	FOOT	900	\$25.00	\$22,500.00
SEEDING, CLASS 1A	ACRE	0.25	\$20,000.00	\$5,000.00
EROSION CONTROL BLANKET	SQ YD	1,000	\$10.00	\$10,000.00
TOTAL LANDSCAPE RESTORATION VALUE				\$45,500.00
STORM SEWER REMOVAL AND REPLACEMENT				
STORM SEWER, 12" (WATER MAIN QUALITY)	FOOT	270	\$80.00	\$21,600.00
STORM SEWER REMOVAL, 12"	FOOT	200	\$10.00	\$2,000.00
INLETS, TYPE A, TYPE 8 GRATE	EACH	2	\$2,500.00	\$5,000.00
CATCH BASINS, 4'-DIAMETER, TYPE 8 GRATE	EACH	3	\$5,000.00	\$15,000.00
DRAINAGE STRUCTURE TO BE REMOVED	EACH	4	\$500.00	\$2,000.00
TOTAL STORM SEWER REMOVAL AND REPLACEMENT COST				\$45,600.00
CONSTRUCTION LAYOUT	L. SUM	1	\$5,000.00	\$5,000.00
TOTAL PROJECT COST				\$215,915.25

DESCRIPTION	ACCOUNT DESCRIPTION	FUND	FY21-22 BUDGET
ROADWAY PAVING AND STRIPING	STORM WATER/DITCH PROJECTS	03-60-4855	\$ 96,900.00
CONCRETE RESTORATION	CURB AND GUTTER PROGRAM	25-35-4376	\$ 23,000.00
LANDSCAPE RESTORATION	67TH STREET STORM SEWER RELOCATION AND LANDSCAPE RESTORATION	25-35-4376	\$ 45,500.00
STORM SEWER REMOVAL AND REPLACEMENT	67TH STREET STORM SEWER RELOCATION AND LANDSCAPE RESTORATION	25-35-4376	\$ 45,600.00
CONSTRUCTION LAYOUT	67TH CONSTRUCTION LAYOUT	25-35-4376	\$ 5,000.00
TOTAL PROJECT COST			\$ 216,000.00

**CHRISTOPHER B. BURKE ENGINEERING, LTD.**

9575 West Higgins Road Suite 600 Rosemont, Illinois 60018 TEL (847) 823-0500 FAX (847) 823-0520

February 9, 2021

City of Darien
1702 Plainfield Road
Darien, IL 60561

Attention: Dan Gombac

Subject: Professional Services Proposal to Provide Construction Layout for the
67th Street Realignment Project, Darien, IL

Dear Mr. Gombac:

Christopher B. Burke Engineering, Ltd. (CBBEL) is pleased to submit this proposal to provide professional land surveying services required for the proposed 67th Street Realignment Project at the Clarendon Road intersection (400' LF±), Darien, IL. This proposal is based on engineering plans prepared by CBBEL.

SCOPE OF SERVICES

We propose the following services to assist you in completion of the project requirements.

Task 1 – Construction Control and Layout:

1. Initial coordination with Client.
2. Office preparation of field staking data.
3. On-site recovery and verification of existing plan horizontal and vertical control (supplied by Client).
4. Construction Layout of Proposed Roadway Paving.
 - Stake back of curb at 50-foot intervals and changes in alignment with graded offsets.
5. Construction Layout of Proposed Utility Improvements.
 - Stake centerline of storm manholes, catch basins, and inlets with graded offsets.

NOTE: All layout of proposed site features will be staked one time in the field. Any restaking or additional layout not included under contract will be billed at the attached hourly rates.

Task 2 – As-built Survey:

1. Initial coordination with Client.
2. Perform field work necessary to prepare final As-built Survey showing final horizontal and vertical location of new roadway and utilities with grades.

3. Office calculations and drafting of final As-built Survey
4. Review by Professional Land Surveyor

It is understood CBBEL will not be responsible for job and site safety on this project; job and site safety shall be the sole responsibility of the Contractor(s). CBBEL does not have the right to stop work and will not advise/schedule/coordinate/supervise the Contractor(s) nor the Contractor(s) means and methods of their work and we shall not be liable for the results of any such interpretations or decisions rendered in good faith.

FEE ESTIMATE

We estimate the cost of the Scope of Services will be:

Task 1 – Construction Control and Layout:	\$3,000.00
Task 2 – As-built Survey:	\$2,000.00
Total	\$5,000.00

We will bill you at the hourly rates specified on the attached Schedule of Charges and establish our contract in accordance with the attached General Terms and Conditions. Direct costs for blueprints, photocopying, mailing, overnight delivery, messenger services and report compilation are not included in the Fee Estimate. These General Terms and Conditions are expressly incorporated into and are an integral part of this contract for professional services. It should be emphasized that any requested meetings or additional services are not included in the preceding Fee Estimate and will be billed at the attached hourly rates.

Please sign and return one copy of this agreement as an indication of acceptance and notice to proceed. Please feel free to contact us anytime.

Sincerely,



Thomas T. Burke, Jr, PhD, PE
 Executive Vice President
 Head Water Resources Department

Encl. Schedule of Charges
 General Terms and Conditions

THIS PROPOSAL, SCHEDULE OF CHARGES AND GENERAL TERMS AND CONDITIONS
 ACCEPTED FOR THE CITY OF DARIEN:

BY: _____
 TITLE: _____
 DATE: _____

CHRISTOPHER B. BURKE ENGINEERING, LTD.
STANDARD CHARGES FOR PROFESSIONAL SERVICES
APRIL, 2020

<u>Personnel</u>	<u>Charges*</u> <u>(\$/Hr)</u>
Principal	275
Engineer VI	251
Engineer V	208
Engineer IV	170
Engineer III	152
Engineer I/II	121
Survey V	229
Survey IV	196
Survey III	172
Survey II	126
Survey I	100
Engineering Technician V	198
Engineering Technician IV	161
Engineering Technician III	146
Engineering Technician I/II	68
CAD Manager	177
Assistant CAD Manager	153
CAD II	135
GIS Specialist III	148
GIS Specialist I/II	94
Landscape Architect	170
Landscape Designer I/II	94
Environmental Resource Specialist V	216
Environmental Resource Specialist IV	170
Environmental Resource Specialist III	139
Environmental Resource Specialist I/II	94
Environmental Resource Technician	114
Administrative	104
Engineering Intern	63
Information Technician III	130
Information Technician I/II	116

Direct Costs

Outside Copies, Blueprints, Messenger, Delivery Services, Mileage Cost + 12%

*Charges include overhead and profit

Christopher B. Burke Engineering, Ltd. reserves the right to increase these rates and costs by 5% after December 31, 2020.

CHRISTOPHER B. BURKE ENGINEERING, LTD.
GENERAL TERMS AND CONDITIONS

1. Relationship Between Engineer and Client: Christopher B. Burke Engineering, Ltd. (Engineer) shall serve as Client's professional engineer consultant in those phases of the Project to which this Agreement applies. This relationship is that of a buyer and seller of professional services and as such the Engineer is an independent contractor in the performance of this Agreement and it is understood that the parties have not entered into any joint venture or partnership with the other. The Engineer shall not be considered to be the agent of the Client. Nothing contained in this Agreement shall create a contractual relationship with a cause of action in favor of a third party against either the Client or Engineer.

Furthermore, causes of action between the parties to this Agreement pertaining to acts of failures to act shall be deemed to have accrued and the applicable statute of limitations shall commence to run not later than the date of substantial completion.

2. Responsibility of the Engineer: Engineer will strive to perform services under this Agreement in accordance with generally accepted and currently recognized engineering practices and principles, and in a manner consistent with that level of care and skill ordinarily exercised by members of the profession currently practicing in the same locality under similar conditions. No other representation, express or implied, and no warranty or guarantee is included or intended in this Agreement, or in any report, opinion, document, or otherwise.

Notwithstanding anything to the contrary which may be contained in this Agreement or any other material incorporated herein by reference, or in any Agreement between the Client and any other party concerning the Project, the Engineer shall not have control or be in charge of and shall not be responsible for the means, methods, techniques, sequences or procedures of construction, or the safety, safety precautions or programs of the Client, the construction contractor, other contractors or subcontractors performing any of the work or providing any of the services on the Project. Nor shall the Engineer be responsible for the acts or omissions of the Client, or for the failure of the Client, any architect, engineer, consultant, contractor or subcontractor to carry out their respective responsibilities in accordance with the Project documents, this Agreement or any other agreement concerning the Project. Any provision which purports to amend this provision shall be without effect unless it contains a reference that the content of this condition is expressly amended for the purposes described in such amendment and is signed by the Engineer.

3. Changes: Client reserves the right by written change order or amendment to make changes in requirements, amount of work, or engineering time schedule adjustments, and Engineer and Client shall negotiate appropriate adjustments acceptable to both parties to accommodate any changes, if commercially possible.
4. Suspension of Services: Client may, at any time, by written order to Engineer (Suspension of Services Order) require Engineer to stop all, or any part, of the services required by this Agreement. Upon receipt of such an order, Engineer shall immediately comply with its terms and take all reasonable steps to minimize the costs associated with the services affected by such order. Client, however, shall pay all costs incurred by the suspension, including all costs necessary to maintain continuity and for the

resumptions of the services upon expiration of the Suspension of Services Order. Engineer will not be obligated to provide the same personnel employed prior to suspension, when the services are resumed, in the event that the period of suspension is greater than thirty (30) days.

5. Termination: This Agreement may be terminated by either party upon thirty (30) days written notice in the event of substantial failure by the other party to perform in accordance with the terms hereof through no fault of the terminating party. This Agreement may be terminated by Client, under the same terms, whenever Client shall determine that termination is in its best interests. Cost of termination, including salaries, overhead and fee, incurred by Engineer either before or after the termination date shall be reimbursed by Client.
6. Documents Delivered to Client: Drawings, specifications, reports, and any other Project Documents prepared by Engineer in connection with any or all of the services furnished hereunder shall be delivered to the Client for the use of the Client. Engineer shall have the right to retain originals of all Project Documents and drawings for its files. Furthermore, it is understood and agreed that the Project Documents such as, but not limited to reports, calculations, drawings, and specifications prepared for the Project, whether in hard copy or machine readable form, are instruments of professional service intended for one-time use in the construction of this Project. These Project Documents are and shall remain the property of the Engineer. The Client may retain copies, including copies stored on magnetic tape or disk, for information and reference in connection with the occupancy and use of the Project.

When and if record drawings are to be provided by the Engineer, Client understands that information used in the preparation of record drawings is provided by others and Engineer is not responsible for accuracy, completeness, nor sufficiency of such information. Client also understands that the level of detail illustrated by record drawings will generally be the same as the level of detail illustrated by the design drawing used for project construction. If additional detail is requested by the Client to be included on the record drawings, then the Client understands and agrees that the Engineer will be due additional compensation for additional services.

It is also understood and agreed that because of the possibility that information and data delivered in machine readable form may be altered, whether inadvertently or otherwise, the Engineer reserves the right to retain the original tapes/disks and to remove from copies provided to the Client all identification reflecting the involvement of the Engineer in their preparation. The Engineer also reserves the right to retain hard copy originals of all Project Documentation delivered to the Client in machine readable form, which originals shall be referred to and shall govern in the event of any inconsistency between the two.

The Client understands that the automated conversion of information and data from the system and format used by the Engineer to an alternate system or format cannot be accomplished without the introduction of inexactitudes, anomalies, and errors. In the event Project Documentation provided to the Client in machine readable form is so converted, the Client agrees to assume all risks associated therewith and, to the fullest

extent permitted by law, to hold harmless and indemnify the Engineer from and against all claims, liabilities, losses, damages, and costs, including but not limited to attorney's fees, arising therefrom or in connection therewith.

The Client recognizes that changes or modifications to the Engineer's instruments of professional service introduced by anyone other than the Engineer may result in adverse consequences which the Engineer can neither predict nor control. Therefore, and in consideration of the Engineer's agreement to deliver its instruments of professional service in machine readable form, the Client agrees, to the fullest extent permitted by law, to hold harmless and indemnify the Engineer from and against all claims, liabilities, losses, damages, and costs, including but not limited to attorney's fees, arising out of or in any way connected with the modification, misinterpretation, misuse, or reuse by others of the machine readable information and data provided by the Engineer under this Agreement. The foregoing indemnification applies, without limitation, to any use of the Project Documentation on other projects, for additions to this Project, or for completion of this Project by others, excepting only such use as may be authorized, in writing, by the Engineer.

7. Reuse of Documents: All Project Documents including but not limited to reports, opinions of probable costs, drawings and specifications furnished by Engineer pursuant to this Agreement are intended for use on the Project only. They cannot be used by Client or others on extensions of the Project or any other project. Any reuse, without specific written verification or adaptation by Engineer, shall be at Client's sole risk, and Client shall indemnify and hold harmless Engineer from all claims, damages, losses, and expenses including attorney's fees arising out of or resulting therefrom.

The Engineer shall have the right to include representations of the design of the Project, including photographs of the exterior and interior, among the Engineer's promotional and professional materials. The Engineer's materials shall not include the Client's confidential and proprietary information if the Client has previously advised the Engineer in writing of the specific information considered by the Client to be confidential and proprietary.

8. Standard of Practice: The Engineer will strive to conduct services under this agreement in a manner consistent with that level of care and skill ordinarily exercised by members of the profession currently practicing in the same locality under similar conditions as of the date of this Agreement.
9. Compliance With Laws: The Engineer will strive to exercise usual and customary professional care in his/her efforts to comply with those laws, codes, ordinance and regulations which are in effect as of the date of this Agreement.

With specific respect to prescribed requirements of the Americans with Disabilities Act of 1990 or certified state or local accessibility regulations (ADA), Client understands ADA is a civil rights legislation and that interpretation of ADA is a legal issue and not a design issue and, accordingly, retention of legal counsel (by Client) for purposes of interpretation is advisable. As such and with respect to ADA, Client agrees to waive any action against Engineer, and to indemnify and defend Engineer against any claim arising from Engineer's alleged failure to meet ADA requirements prescribed.

Further to the law and code compliance, the Client understands that the Engineer will strive to provide designs in accordance with the prevailing Standards of Practice as previously set forth, but that the Engineer does not warrant that any reviewing agency having jurisdiction will not for its own purposes comment, request changes and/or additions to such designs. In the event such design requests are made by a reviewing agency, but which do not exist in the form of a written regulation, ordinance or other similar document as published by the reviewing agency, then such design changes (at substantial variance from the intended design developed by the Engineer), if effected and incorporated into the project documents by the Engineer, shall be considered as Supplementary Task(s) to the Engineer's Scope of Service and compensated for accordingly.

10. Indemnification: Engineer shall indemnify and hold harmless Client up to the amount of this contract fee (for services) from loss or expense, including reasonable attorney's fees for claims for personal injury (including death) or property damage to the extent caused by the sole negligent act, error or omission of Engineer.

Client shall indemnify and hold harmless Engineer under this Agreement, from loss or expense, including reasonable attorney's fees, for claims for personal injuries (including death) or property damage arising out of the sole negligent act, error omission of Client.

In the event of joint or concurrent negligence of Engineer and Client, each shall bear that portion of the loss or expense that its share of the joint or concurrent negligence bears to the total negligence (including that of third parties), which caused the personal injury or property damage.

Engineer shall not be liable for special, incidental or consequential damages, including, but not limited to loss of profits, revenue, use of capital, claims of customers, cost of purchased or replacement power, or for any other loss of any nature, whether based on contract, tort, negligence, strict liability or otherwise, by reasons of the services rendered under this Agreement.

11. Opinions of Probable Cost: Since Engineer has no control over the cost of labor, materials or equipment, or over the Contractor(s) method of determining process, or over competitive bidding or market conditions, his/her opinions of probable Project Construction Cost provided for herein are to be made on the basis of his/her experience and qualifications and represent his/her judgement as a design professional familiar with the construction industry, but Engineer cannot and does not guarantee that proposal, bids or the Construction Cost will not vary from opinions of probable construction cost prepared by him/her. If prior to the Bidding or Negotiating Phase, Client wishes greater accuracy as to the Construction Cost, the Client shall employ an independent cost estimator Consultant for the purpose of obtaining a second construction cost opinion independent from Engineer.
12. Governing Law & Dispute Resolutions: This Agreement shall be governed by and construed in accordance with Articles previously set forth by (Item 9 of) this Agreement, together with the laws of the **State of Illinois**.

Any claim, dispute or other matter in question arising out of or related to this Agreement, which can not be mutually resolved by the parties of this Agreement, shall be subject to mediation as a condition precedent to arbitration (if arbitration is agreed upon by the parties of this Agreement) or the institution of legal or equitable proceedings by either party. If such matter relates to or is the subject of a lien arising out of the Engineer's services, the Engineer may proceed in accordance with applicable law to comply with the lien notice or filing deadlines prior to resolution of the matter by mediation or by arbitration.

The Client and Engineer shall endeavor to resolve claims, disputes and other matters in question between them by mediation which, unless the parties mutually agree otherwise, shall be in accordance with the Construction Industry Mediation Rules of the American Arbitration Association currently in effect. Requests for mediation shall be filed in writing with the other party to this Agreement and with the American Arbitration Association. The request may be made concurrently with the filing of a demand for arbitration but, in such event, mediation shall proceed in advance of arbitration or legal or equitable proceedings, which shall be stayed pending mediation for a period of 60 days from the date of filing, unless stayed for a longer period by agreement of the parties or court order.

The parties shall share the mediator's fee and any filing fees equally. The mediation shall be held in the place where the Project is located, unless another location is mutually agreed upon. Agreements reached in mediation shall be enforceable as settlement agreements in any court having jurisdiction thereof.

13. Successors and Assigns: The terms of this Agreement shall be binding upon and inure to the benefit of the parties and their respective successors and assigns: provided, however, that neither party shall assign this Agreement in whole or in part without the prior written approval of the other.
14. Waiver of Contract Breach: The waiver of one party of any breach of this Agreement or the failure of one party to enforce at any time, or for any period of time, any of the provisions hereof, shall be limited to the particular instance, shall not operate or be deemed to waive any future breaches of this Agreement and shall not be construed to be a waiver of any provision, except for the particular instance.
15. Entire Understanding of Agreement: This Agreement represents and incorporates the entire understanding of the parties hereto, and each party acknowledges that there are no warranties, representations, covenants or understandings of any kind, matter or description whatsoever, made by either party to the other except as expressly set forth herein. Client and the Engineer hereby agree that any purchase orders, invoices, confirmations, acknowledgments or other similar documents executed or delivered with respect to the subject matter hereof that conflict with the terms of the Agreement shall be null, void & without effect to the extent they conflict with the terms of this Agreement.
16. Amendment: This Agreement shall not be subject to amendment unless another instrument is duly executed by duly authorized representatives of each of the parties and entitled "Amendment of Agreement".

17. Severability of Invalid Provisions: If any provision of the Agreement shall be held to contravene or to be invalid under the laws of any particular state, county or jurisdiction where used, such contravention shall not invalidate the entire Agreement, but it shall be construed as if not containing the particular provisions held to be invalid in the particular state, country or jurisdiction and the rights or obligations of the parties hereto shall be construed and enforced accordingly.
18. Force Majeure: Neither Client nor Engineer shall be liable for any fault or delay caused by any contingency beyond their control including but not limited to acts of God, wars, strikes, walkouts, fires, natural calamities, or demands or requirements of governmental agencies.
19. Subcontracts: Engineer may subcontract portions of the work, but each subcontractor must be approved by Client in writing.
20. Access and Permits: Client shall arrange for Engineer to enter upon public and private property and obtain all necessary approvals and permits required from all governmental authorities having jurisdiction over the Project. Client shall pay costs (including Engineer's employee salaries, overhead and fee) incident to any effort by Engineer toward assisting Client in such access, permits or approvals, if Engineer perform such services.
21. Designation of Authorized Representative: Each party (to this Agreement) shall designate one or more persons to act with authority in its behalf in respect to appropriate aspects of the Project. The persons designated shall review and respond promptly to all communications received from the other party.
22. Notices: Any notice or designation required to be given to either party hereto shall be in writing, and unless receipt of such notice is expressly required by the terms hereof shall be deemed to be effectively served when deposited in the mail with sufficient first class postage affixed, and addressed to the party to whom such notice is directed at such party's place of business or such other address as either party shall hereafter furnish to the other party by written notice as herein provided.
23. Limit of Liability: The Client and the Engineer have discussed the risks, rewards, and benefits of the project and the Engineer's total fee for services. In recognition of the relative risks and benefits of the Project to both the Client and the Engineer, the risks have been allocated such that the Client agrees that to the fullest extent permitted by law, the Engineer's total aggregate liability to the Client for any and all injuries, claims, costs, losses, expenses, damages of any nature whatsoever or claim expenses arising out of this Agreement from any cause or causes, including attorney's fees and costs, and expert witness fees and costs, shall not exceed the total Engineer's fee for professional engineering services rendered on this project as made part of this Agreement. Such causes included but are not limited to the Engineer's negligence, errors, omissions, strict liability or breach of contract. It is intended that this limitation apply to any and all liability or cause of action however alleged or arising, unless otherwise prohibited by law.

24. Client's Responsibilities: The Client agrees to provide full information regarding requirements for and about the Project, including a program which shall set forth the Client's objectives, schedule, constraints, criteria, special equipment, systems and site requirements.

The Client agrees to furnish and pay for all legal, accounting and insurance counseling services as may be necessary at any time for the Project, including auditing services which the Client may require to verify the Contractor's Application for Payment or to ascertain how or for what purpose the Contractor has used the money paid by or on behalf of the Client.

The Client agrees to require the Contractor, to the fullest extent permitted by law, to indemnify, hold harmless, and defend the Engineer, its consultants, and the employees and agents of any of them from and against any and all claims, suits, demands, liabilities, losses, damages, and costs ("Losses"), including but not limited to costs of defense, arising in whole or in part out of the negligence of the Contractor, its subcontractors, the officers, employees, agents, and subcontractors of any of them, or anyone for whose acts any of them may be liable, regardless of whether or not such Losses are caused in part by a party indemnified hereunder. Specifically excluded from the foregoing are Losses arising out of the preparation or approval of maps, drawings, opinions, reports, surveys, change orders, designs, or specifications, and the giving of or failure to give directions by the Engineer, its consultants, and the agents and employees of any of them, provided such giving or failure to give is the primary cause of Loss. The Client also agrees to require the Contractor to provide to the Engineer the required certificate of insurance.

The Client further agrees to require the Contractor to name the Engineer, its agents and consultants as additional insureds on the Contractor's policy or policies of comprehensive or commercial general liability insurance. Such insurance shall include products and completed operations and contractual liability coverages, shall be primary and noncontributing with any insurance maintained by the Engineer or its agents and consultants, and shall provide that the Engineer be given thirty days, unqualified written notice prior to any cancellation thereof.

In the event the foregoing requirements, or any of them, are not established by the Client and met by the Contractor, the Client agrees to indemnify and hold harmless the Engineer, its employees, agents, and consultants from and against any and all Losses which would have been indemnified and insured against by the Contractor, but were not.

When Contract Documents prepared under the Scope of Services of this contract require insurance(s) to be provided, obtained and/or otherwise maintained by the Contractor, the Client agrees to be wholly responsible for setting forth any and all such insurance requirements. Furthermore, any document provided for Client review by the Engineer under this Contract related to such insurance(s) shall be considered as sample insurance requirements and not the recommendation of the Engineer. Client agrees to have their own risk management department review any and all insurance requirements for adequacy and to determine specific types of insurance(s) required for the project. Client further agrees that decisions concerning types and amounts of insurance are

specific to the project and shall be the product of the Client. As such, any and all insurance requirements made part of Contract Documents prepared by the Engineer are not to be considered the Engineer's recommendation, and the Client shall make the final decision regarding insurance requirements.

25. Information Provided by Others: The Engineer shall indicate to the Client the information needed for rendering of the services of this Agreement. The Client shall provide to the Engineer such information as is available to the Client and the Client's consultants and contractors, and the Engineer shall be entitled to rely upon the accuracy and completeness thereof. The Client recognizes that it is impossible for the Engineer to assure the accuracy, completeness and sufficiency of such information, either because it is impossible to verify, or because of errors or omissions which may have occurred in assembling the information the Client is providing. Accordingly, the Client agrees, to the fullest extent permitted by law, to indemnify and hold the Engineer and the Engineer's subconsultants harmless from any claim, liability or cost (including reasonable attorneys' fees and cost of defense) for injury or loss arising or allegedly arising from errors, omissions or inaccuracies in documents or other information provided by the Client to the Engineer.

26. Payment: Client shall be invoiced once each month for work performed during the preceding period. Client agrees to pay each invoice within thirty (30) days of its receipt. The client further agrees to pay interest on all amounts invoiced and not paid or objected to for valid cause within said thirty (30) day period at the rate of eighteen (18) percent per annum (or the maximum interest rate permitted under applicable law, whichever is the lesser) until paid. Client further agrees to pay Engineer's cost of collection of all amounts due and unpaid after sixty (60) days, including court costs and reasonable attorney's fees, as well as costs attributed to suspension of services accordingly and as follows:

Collection Costs. In the event legal action is necessary to enforce the payment provisions of this Agreement, the Engineer shall be entitled to collect from the Client any judgement or settlement sums due, reasonable attorneys' fees, court costs and expenses incurred by the Engineer in connection therewith and, in addition, the reasonable value of the Engineer's time and expenses spent in connection with such collection action, computed at the Engineer's prevailing fee schedule and expense policies.

Suspension of Services. If the Client fails to make payments when due or otherwise is in breach of this Agreement, the Engineer may suspend performance of services upon five (5) calendar days' notice to the Client. The Engineer shall have no liability whatsoever to the Client for any costs or damages as a result of such suspension caused by any breach of this Agreement by the Client. Client will reimburse Engineer for all associated costs as previously set forth in (Item 4 of) this Agreement.

27. When construction observation tasks are part of the service to be performed by the Engineer under this Agreement, the Client will include the following clause in the construction contract documents and Client agrees not to modify or delete it:

Kotecki Waiver. Contractor (and any subcontractor into whose subcontract this clause is incorporated) agrees to assume the entire liability for all personal injury claims suffered by its own employees, including without limitation claims under the **Illinois** Structural Work Act, asserted by persons allegedly injured on the Project; waives any limitation of liability defense based upon the Worker's Compensation Act, court interpretations of said Act or otherwise; and to the fullest extent permitted by law, agrees to indemnify and hold harmless and defend Owner and Engineer and their agents, employees and consultants (the "Indemnitees") from and against all such loss, expense, damage or injury, including reasonable attorneys' fees, that the Indemnitees may sustain as a result of such claims, except to the extent that **Illinois** law prohibits indemnity for the Indemnitees' own negligence. The Owner and Engineer are designated and recognized as explicit third party beneficiaries of the Kotecki Waiver within the general contract and all subcontracts entered into in furtherance of the general contract.

28. Job Site Safety/Supervision & Construction Observation: The Engineer shall neither have control over or charge of, nor be responsible for, the construction means, methods, techniques, sequences of procedures, or for safety precautions and programs in connection with the Work since they are solely the Contractor's rights and responsibilities. The Client agrees that the Contractor shall supervise and direct the work efficiently with his/her best skill and attention; and that the Contractor shall be solely responsible for the means, methods, techniques, sequences and procedures of construction and safety at the job site. The Client agrees and warrants that this intent shall be carried out in the Client's contract with the Contractor. The Client further agrees that the Contractor shall be responsible for initiating, maintaining and supervising all safety precautions and programs in connection with the work; and that the Contractor shall take all necessary precautions for the safety of, and shall provide the necessary protection to prevent damage, injury or loss to all employees on the subject site and all other persons who may be affected thereby. The Engineer shall have no authority to stop the work of the Contractor or the work of any subcontractor on the project.

When construction observation services are included in the Scope of Services, the Engineer shall visit the site at intervals appropriate to the stage of the Contractor's operation, or as otherwise agreed to by the Client and the Engineer to: 1) become generally familiar with and to keep the Client informed about the progress and quality of the Work; 2) to strive to bring to the Client's attention defects and deficiencies in the Work and; 3) to determine in general if the Work is being performed in a manner indicating that the Work, when fully completed, will be in accordance with the Contract Documents. However, the Engineer shall not be required to make exhaustive or continuous on-site inspections to check the quality or quantity of the Work. If the Client desires more extensive project observation, the Client shall request that such services be provided by the Engineer as Additional and Supplemental Construction Observation Services in accordance with the terms of this Agreement.

The Engineer shall not be responsible for any acts or omissions of the Contractor, subcontractor, any entity performing any portions of the Work, or any agents or employees of any of them. The Engineer does not guarantee the performance of the

Contractor and shall not be responsible for the Contractor's failure to perform its Work in accordance with the Contract Documents or any applicable laws, codes, rules or regulations.

When municipal review services are included in the Scope of Services, the Engineer (acting on behalf of the municipality), when acting in good faith in the discharge of its duties, shall not thereby render itself liable personally and is, to the maximum extent permitted by law, relieved from all liability for any damage that may accrue to persons or property by reason of any act or omission in the discharge of its duties. Any suit brought against the Engineer which involve the acts or omissions performed by it in the enforcement of any provisions of the Client's rules, regulation and/or ordinance shall be defended by the Client until final termination of the proceedings. The Engineer shall be entitled to all defenses and municipal immunities that are, or would be, available to the Client.

29. Insurance and Indemnification: The Engineer and the Client understand and agree that the Client will contractually require the Contractor to defend and indemnify the Engineer and/or any subconsultants from any claims arising from the Work. The Engineer and the Client further understand and agree that the Client will contractually require the Contractor to procure commercial general liability insurance naming the Engineer as an additional named insured with respect to the work. The Contractor shall provide to the Client certificates of insurance evidencing that the contractually required insurance coverage has been procured. However, the Contractor's failure to provide the Client with the requisite certificates of insurance shall not constitute a waiver of this provision by the Engineer.

The Client and Engineer waive all rights against each other and against the Contractor and consultants, agents and employees of each of them for damages to the extent covered by property insurance during construction. The Client and Engineer each shall require similar waivers from the Contractor, consultants, agents and persons or entities awarded separate contracts administered under the Client's own forces.

30. Hazardous Materials/Pollutants: Unless otherwise provided by this Agreement, the Engineer and Engineer's consultants shall have no responsibility for the discovery, presence, handling, removal or disposal of or exposure of persons to hazardous materials/pollutants in any form at the Project site, including but not limited to mold/mildew, asbestos, asbestos products, polychlorinated biphenyl (PCB) or other toxic/hazardous/pollutant type substances.

Furthermore, Client understands that the presence of mold/mildew and the like are results of prolonged or repeated exposure to moisture and the lack of corrective action. Client also understands that corrective action is a operation, maintenance and repair activity for which the Engineer is not responsible.

RESOLUTION NO. _____

A RESOLUTION AUTHORIZING THE MAYOR TO ACCEPT A PROPOSAL FROM CHRISTOPHER B. BURKE ENGINEERING, LTD. FOR THE PROFESSIONAL DESIGN SERVICES RELATED TO THE CONSTRUCTION LAYOUT SERVICES FOR THE GEOMETRICAL RECONFIGURATION OF 67TH STREET-ADJACENT TO THE WESTERN LEG OF CLARENDON HILLS ROAD IN AN AMOUNT NOT TO EXCEED \$5,000

BE IT RESOLVED BY THE CITY COUNCIL OF THE CITY OF DARIEN, DU PAGE COUNTY, ILLINOIS, as follows:

SECTION 1: The City Council of the City of Darien, hereby authorizes the Mayor to accept a proposal from Christopher B. Burke Engineering, Ltd. for the professional design services related to the Construction Layout Services for the geometrical reconfiguration of 67th Street-adjacent to the western leg of Clarendon Hills Road in an amount not to exceed \$5,000 a copy of which is attached hereto as “[Exhibit A](#)” and is by this reference expressly incorporated hereto.

SECTION 2: This Resolution shall be in full force and effect from and after its passage and approval as provided by law.

PASSED BY THE CITY COUNCIL OF THE CITY OF DARIEN, DU PAGE COUNTY, ILLINOIS, this 1st day of March, 2021.

AYES: _____

NAYS: _____

ABSENT: _____

APPROVED BY THE MAYOR OF THE CITY OF DARIEN, DU PAGE COUNTY, ILLINOIS, this 1st day of March, 2021.

JOSEPH MARCHESE, MAYOR

ATTEST:

JOANNE E. RAGONA, CITY CLERK

APPROVED AS TO FORM:

CITY ATTORNEY

**CHRISTOPHER B. BURKE ENGINEERING, LTD.**

9575 West Higgins Road Suite 600 Rosemont, Illinois 60018 TEL (847) 823-0500 FAX (847) 823-0520

February 9, 2021

City of Darien
1702 Plainfield Road
Darien, IL 60561

Attention: Dan Gombac

Subject: Professional Services Proposal to Provide Construction Layout for the
67th Street Realignment Project, Darien, IL

Dear Mr. Gombac:

Christopher B. Burke Engineering, Ltd. (CBBEL) is pleased to submit this proposal to provide professional land surveying services required for the proposed 67th Street Realignment Project at the Clarendon Road intersection (400' LF±), Darien, IL. This proposal is based on engineering plans prepared by CBBEL.

SCOPE OF SERVICES

We propose the following services to assist you in completion of the project requirements.

Task 1 – Construction Control and Layout:

1. Initial coordination with Client.
2. Office preparation of field staking data.
3. On-site recovery and verification of existing plan horizontal and vertical control (supplied by Client).
4. Construction Layout of Proposed Roadway Paving.
 - Stake back of curb at 50-foot intervals and changes in alignment with graded offsets.
5. Construction Layout of Proposed Utility Improvements.
 - Stake centerline of storm manholes, catch basins, and inlets with graded offsets.

NOTE: All layout of proposed site features will be staked one time in the field. Any restaking or additional layout not included under contract will be billed at the attached hourly rates.

Task 2 – As-built Survey:

1. Initial coordination with Client.
2. Perform field work necessary to prepare final As-built Survey showing final horizontal and vertical location of new roadway and utilities with grades.

3. Office calculations and drafting of final As-built Survey
4. Review by Professional Land Surveyor

It is understood CBBEL will not be responsible for job and site safety on this project; job and site safety shall be the sole responsibility of the Contractor(s). CBBEL does not have the right to stop work and will not advise/schedule/coordinate/supervise the Contractor(s) nor the Contractor(s) means and methods of their work and we shall not be liable for the results of any such interpretations or decisions rendered in good faith.

FEE ESTIMATE

We estimate the cost of the Scope of Services will be:

Task 1 – Construction Control and Layout:		\$3,000.00
Task 2 – As-built Survey:		\$2,000.00
	Total	\$5,000.00

We will bill you at the hourly rates specified on the attached Schedule of Charges and establish our contract in accordance with the attached General Terms and Conditions. Direct costs for blueprints, photocopying, mailing, overnight delivery, messenger services and report compilation are not included in the Fee Estimate. These General Terms and Conditions are expressly incorporated into and are an integral part of this contract for professional services. It should be emphasized that any requested meetings or additional services are not included in the preceding Fee Estimate and will be billed at the attached hourly rates.

Please sign and return one copy of this agreement as an indication of acceptance and notice to proceed. Please feel free to contact us anytime.

Sincerely,



Thomas T. Burke, Jr, PhD, PE
 Executive Vice President
 Head Water Resources Department

Encl. Schedule of Charges
 General Terms and Conditions

THIS PROPOSAL, SCHEDULE OF CHARGES AND GENERAL TERMS AND CONDITIONS
 ACCEPTED FOR THE CITY OF DARIEN:

BY: _____
 TITLE: _____
 DATE: _____

AGENDA MEMO
Municipal Services Committee
February 22, 2021

ISSUE STATEMENT

Consideration for the authorization to execute an Illinois Department of Transportation [Resolution](#), (IDOT BLR 14220) authorizing the expenditure of Motor Fuel Tax (MFT) funds for the FY 2021/22 General Maintenance items in the amount of \$565,788.37 for a period from May 1, 2021 through April 30, 2022. [BACKUP](#)

AND

Consideration for the authorization to execute an Illinois Department of Transportation [Resolution](#), (IDOT BLR 14220) authorizing the expenditure of funds for the Rebuild Illinois Bonds Program in the amount of \$1,428,770.30 for a period from May 1, 2021 through April 30, 2022 from grants made from bond sale proceeds that must be deposited in the Local Public agency (LPA) MFT account and tracked separately.

BACKGROUND/HISTORY

The City of Darien utilizes Motor Fuel Tax Funds (MFT) for expenditures related to various street maintenance functions. The funding provides for expenditures for such items as salaries, the purchase of rock salt, cold and hot bituminous surface mixes, and storm sewer related items, various aggregate materials and road striping. Because MFT funds are utilized, the City Council is required to adopt a resolution authorizing the expenditure of the proposed funding related to the general maintenance items. Attached as, [Attachment A](#) is the Bureau of Local Road Forms Municipal Estimate of Maintenance Costs and Request for Expenditure/Authorization of Motor Fuel Tax Funds (BLR 14222 and BLR 09150).

One June 28, 2019 Governor Pritzker signed REBUILD ILLINOIS (RBI) Capital Plan to fund transportation projects and improvements, along with many other investments. This is not an MFT distribution, rather a grant made from bond sale proceeds that must be deposited into the LPA MFT account and tracked separately as RBI spends. Attached and labeled as [Attachment B](#) is the Bureau of Local Road Forms Municipal Estimate of Maintenance Costs and Request for Expenditure/Authorization of Motor Fuel Tax Funds (BLR 14222 and BLR 09150) for the Rebuild Illinois Bonds Program.

STAFF RECOMMENDATION

Staff recommends approval of these Resolutions.

ALTERNATE CONSIDERATION

As directed by the City Council.

DECISION MODE

This item will be placed on the March 1, 2021 City Council agenda, New Business for formal approval.



March 1, 2021

Mr. Anthony Quigley, P.E.
Deputy Directors of Highways,
Region One Engineer
Division of Highways/Region One/District One
201 West Center Ct.
Schaumburg, IL 60196-1096

RE: Section Number 22-00000-00-RF

Dear Mr. Quigley:

In accordance with the Bureau of Local Roads and Streets Administrative Policy Manual, the following is an estimate of the allotted MFT monies to spend by the City during the Fiscal Year ending April 30, 2022:

Estimated Total Expenditures for:

FICA	\$15,190
IMRF	\$32,095
MEDICARE	\$ 3,553
TOTAL	\$50,838

If you have any questions regarding this matter, please contact Dan Gombac, Director of Municipal Services at dgombac@darienil.gov or via telephone at (630)353-8106.

Sincerely,
CITY OF DARIEN

Daniel Gombac
Director of Municipal Services

cc: Bryon Vana, City Administrator
Julie Saenz, City Accountant



Local Public Agency General Maintenance



Estimate of Maintenance Costs

Submittal Type

Maintenance Period

Local Public Agency	County	Section Number	Beginning	Ending
City of Darien	DuPage	22-00000-00-GM	05/01/21	04/30/22

Maintenance Items

Maintenance Operation	Maint Eng Category	Insp. Req.	Material Categories/ Point of Delivery or Work Performed by an Outside Contractor	Unit	Quantity	Unit Cost	Cost	Total Maintenance Operation Cost
1)Aggregate Stone	IIA		Stone CA-6 CA-7	Tons	1,000	\$17.50	\$17,500.00	
(Should Maint)			Labor-5 Gen Util Wkrs City Staff	Av Hr	15	\$42.00	\$630.00	\$18,130.00
2)Snow & Ice Control	I		Road Salt-Joint Purchase	Tons	2,500	\$85.50	\$213,750.00	
	III		Geo Melt 55 NIGP Code	Gallons	8,000	\$4.13	\$33,040.00	
			Labor-5 Gen Util Wkrs City Staff	Av Hr	1,442	\$37.53	\$54,118.26	\$300,908.26
3)Storm Sewer Maint	I		Storm Sewer Material -environmentaly friendly-	LS	1	\$18,500.00	\$18,500.00	
			Labor-5 Gen Util Wkrs City Staff	Av Hr	1,535	\$33.26	\$51,054.10	\$69,554.10
4)Pavement Marking	IIB		Striping-Paint-Thermal Contract NWMC	LS	1	\$34,500.00	\$34,500.00	
	IIA		Labor-5 Gen Util Wkrs City Staff	Av Hr	86	\$36.01	\$3,096.86	\$37,596.86
5)Street Sign Maint	IIA		Sign	LS	1	\$10,000.00	\$10,000.00	
	IIA		Labor-5 Gen Util Wkrs City Staff	Av Hr	85	\$36.01	\$3,060.85	\$13,060.85
6)Mowing (Public ROW)	IIA		Labor-5 Gen Util Wkrs City Staff	Av Hr	1,265	\$28.15	\$35,609.75	\$35,609.75
7)Catch Basin Cleaning Jetting	IIA		Labor-5 Gen Util Wkrs City Staff	Av Hr	275	\$37.07	\$10,194.25	
			Equipment Rental	LS	1	\$5,000.00	\$5,000.00	\$15,194.25
8)Tree Trimming	IIA		Tree Trimming-City Staff safety or an emergency	Av Hr	200	\$25.00	\$5,000.00	
	IIA		Labor-5 Gen Util Wkrs City Staff	Av Hr	385	\$49.18	\$18,934.30	\$23,934.30
9)Concrete Gen Maint Inspection	IIA		Labor-1 Gen Util Wkr City Staff	Av Hr	480	\$35.00	\$16,800.00	\$16,800.00
10)Energy power distribution	I		Power Cost-contract Com Ed/Constellation	LS	1	\$35,000.00	\$35,000.00	\$35,000.00
Total Operation Cost								\$565,788.37

Estimate of Maintenance Costs

Submittal Type Original

Local Public Agency	County	Section	Maintenance Period	
			Beginning	Ending
City of Darien	DuPage	22-00000-00-GM	05/01/21	04/30/22

Estimate of Maintenance Costs Summary

	MFT Funds	RBI Funds	Other Funds	Estimated Costs
Maintenance				
Local Public Agency Labor	\$193,498.37			\$193,498.37
Local Public Agency Equipment				
Materials/Contracts(Non Bid Items)	\$372,290.00			\$372,290.00
Materials/Deliver & Install/Materials Quotations (Bid Items)				
Formal Contract (Bid Items)				
Maintenance Total	\$565,788.37			\$565,788.37

Estimated Maintenance Eng Costs Summary

	MFT Funds	RBI Funds	Other Funds	Total Est Costs
Maintenance Engineering				
Preliminary Engineering				
Engineering Inspection				
Material Testing				
Advertising				
Bridge Inspection Engineering				
Maintenance Engineering Total				
Total Estimated Maintenance	\$565,788.37			\$565,788.37

Remarks

SUBMITTED

Local Public Agency Official Date

Title **Mayor**

County Engineer/Superintendent of Highways Date

APPROVED

Regional Engineer Date
 Department of Transportation



Request for Expenditure/Authorization of Motor Fuel Tax Funds



Local Public Agency

Darien

Type

City

County

DuPage

Section Number

22-00000-00-GM

I hereby request authorization to expend Motor Fuel Tax Funds as indicated below:

Purpose	Amount
County Engineer/Superintendent Salary & Expenses	
Contract Construction	
Day Labor Construction	
Engineering	
Engineering Investigations	
IMRF/Social Security	
Maintenance	\$565,788.37
Maintenance Engineering	
Obligation Retirement	
Other	
Right-of-Way (Itemized on 2nd page)	
TOTAL	\$565,788.37

Comments

Local Public Agency Official

Date

Title

Mayor

Approved

Regional Engineer
Department of Transportation

Date

Department of Transportation Use

Entered By

Date

Itemization of Right-of-Way Request

Location of Property			Property Owner	Acres Right-of-Way	Relocation Costs	Cost of Land Acquired	Cost of Damage to Land not Acquired	Total
Street/Road	Parcel Number	Address of Property Involved						
n/a								
							TOTAL	

Add Item



Request for Expenditure/Authorization of Motor Fuel Tax Funds



Local Public Agency City of Darien	Type City	County DuPage	Section Number 22-00000-00-GM
---------------------------------------	--------------	------------------	----------------------------------

I hereby request authorization to expend Motor Fuel Tax Funds as indicated below:

Purpose	Amount
County Engineer/Superintendent Salary & Expenses	
Contract Construction	
Day Labor Construction	
Engineering	
Engineering Investigations	
IMRF/Social Security	\$50,838.00
Maintenance	
Maintenance Engineering	
Obligation Retirement	
Other	
Right-of-Way (Itemized on 2nd page)	
TOTAL	\$50,838.00

Comments

Local Public Agency Official	Date

Title

Mayor

Approved

Regional Engineer Department of Transportation	Date

Department of Transportation Use

Entered By	Date

Itemization of Right-of-Way Request

Location of Property			Property Owner	Acres Right-of- Way	Relocation Costs	Cost of Land Acquired	Cost of Damage to Land not Acquired	Total
Street/Road	Parcel Number	Address of Property Involved						
TOTAL								

Add Item



Resolution for Maintenance Under the Illinois Highway Code



Resolution Number	Resolution Type	Section Number
	Original	22-00000-00-GM

BE IT RESOLVED, by the Council of the Darien of Darien Illinois that there is hereby appropriated the sum of five hundred sixty five thousand seven hundred eighty eight dollars and thirty seven cents Dollars (\$565,788.37)

of Motor Fuel Tax funds for the purpose of maintaining streets and highways under the applicable provisions of Illinois Highway Code from 01/01/21 to 12/31/21.

BE IT FURTHER RESOLVED, that only those operations as listed and described on the approved Estimate of Maintenance Costs, including supplemental or revised estimates approved in connection with this resolution, are eligible for maintenance with Motor Fuel Tax funds during the period as specified above.

BE IT FURTHER RESOLVED, that City of Darien shall submit within three months after the end of the maintenance period as stated above, to the Department of Transportation, on forms available from the Department, a certified statement showing expenditures and the balances remaining in the funds authorized for expenditure by the Department under this appropriation, and

BE IT FURTHER RESOLVED, that the Clerk is hereby directed to transmit four (4) certified originals of this resolution to the district office of the Department of Transportation.

I JoAnne Ragona City Clerk in and for said City of Darien in the State of Illinois, and keeper of the records and files thereof, as provided by statute, do hereby certify the foregoing to be a true, perfect and complete copy of a resolution adopted by the Council of Darien at a meeting held on _____.

IN TESTIMONY WHEREOF, I have hereunto set my hand and seal this _____ day of _____ Month, Year _____.

(SEAL)

Clerk Signature

APPROVED

Regional Engineer
Department of Transportation

Date



Local Public Agency General Maintenance



Estimate of Maintenance Costs

Submittal Type

Maintenance Period

Local Public Agency	County	Section Number	Beginning	Ending
City of Darien	DuPage	22-00000-00-GM	01/01/21	12/31/21

Maintenance Items

Maintenance Operation	Maint Eng Category	Insp. Req.	Material Categories/ Point of Delivery or Work Performed by an Outside Contractor	Unit	Quantity	Unit Cost	Cost	Total Maintenance Operation Cost
20-00030-00-FP	IIB	No	ROAD MAINTENANCE	LS	1	\$1,428,770.30	\$1,428,770.30	\$1,428,770.30
Total Operation Cost								\$1,428,770.30

Estimate of Maintenance Costs

Submittal Type Original

Local Public Agency	County	Section	Maintenance Period	
			Beginning	Ending
City of Darien	DuPage	22-00000-00-GM	01/01/21	12/31/21

Estimate of Maintenance Costs Summary

	MFT Funds	RBI Funds	Other Funds	Estimated Costs
Maintenance				
Local Public Agency Labor				
Local Public Agency Equipment				
Materials/Contracts(Non Bid Items)				
Materials/Deliver & Install/Materials Quotations (Bid Items)				
Formal Contract (Bid Items)		\$1,428,770.30		\$1,428,770.30
Maintenance Total				

Estimated Maintenance Eng Costs Summary

	MFT Funds	RBI Funds	Other Funds	Total Est Costs
Maintenance Engineering				
Preliminary Engineering				
Engineering Inspection				
Material Testing				
Advertising				
Bridge Inspection Engineering				
Maintenance Engineering Total				
Total Estimated Maintenance		\$1,428,770.30		\$1,428,770.30

Remarks

SUBMITTED

Local Public Agency Official Date

Title MAYOR

County Engineer/Superintendent of Highways Date

APPROVED

Regional Engineer
Department of Transportation Date



Request for Expenditure/Authorization of Motor Fuel Tax Funds



Local Public Agency

Type

County

Section Number

Darien

City

DuPage

20-00030-00-FP

I hereby request authorization to expend Motor Fuel Tax Funds as indicated below:

Purpose	Amount
County Engineer/Superintendent Salary & Expenses	
Contract Construction	\$1,428,770.30
Day Labor Construction	
Engineering	
Engineering Investigations	
IMRF/Social Security	
Maintenance	
Maintenance Engineering	
Obligation Retirement	
Other	
Right-of-Way (Itemized on 2nd page)	
TOTAL	\$1,428,770.30

Comments

Local Public Agency Official

Date

Title

Mayor

Approved

Regional Engineer

Department of Transportation

Date

Department of Transportation Use

Entered By

Date

Itemization of Right-of-Way Request

Location of Property			Property Owner	Acres Right-of-Way	Relocation Costs	Cost of Land Acquired	Cost of Damage to Land not Acquired	Total
Street/Road	Parcel Number	Address of Property Involved						
n/a								
							TOTAL	

Add Item



Resolution for Maintenance Under the Illinois Highway Code



Resolution Number	Resolution Type	Section Number
	Original	20-00030-00-FP

BE IT RESOLVED, by the Council of the City of Darien of Darien Illinois that there is hereby appropriated the sum of **one million four hundred twenty eight thousand seven hundred seventy dollars and thirty cents.** Dollars (\$1,428,770.30)

of Motor Fuel Tax funds for the purpose of maintaining streets and highways under the applicable provisions of Illinois Highway Code from 01/01/21 to 12/31/21.

BE IT FURTHER RESOLVED, that only those operations as listed and described on the approved Estimate of Maintenance Costs, including supplemental or revised estimates approved in connection with this resolution, are eligible for maintenance with Motor Fuel Tax funds during the period as specified above.

BE IT FURTHER RESOLVED, that City of Darien shall submit within three months after the end of the maintenance period as stated above, to the Department of Transportation, on forms available from the Department, a certified statement showing expenditures and the balances remaining in the funds authorized for expenditure by the Department under this appropriation, and

BE IT FURTHER RESOLVED, that the Clerk is hereby directed to transmit four (4) certified originals of this resolution to the district office of the Department of Transportation.

I JoAnne Ragona City Clerk in and for said City of Darien in the State of Illinois, and keeper of the records and files thereof, as provided by statute, do hereby certify the foregoing to be a true, perfect and complete copy of a resolution adopted by the Council of Darien at a meeting held on _____.

IN TESTIMONY WHEREOF, I have hereunto set my hand and seal this _____ day of _____ Month, Year _____.

(SEAL)

Clerk Signature

APPROVED

Regional Engineer
Department of Transportation

Date

AGENDA MEMO
Municipal Services Committee
February 22, 2021

Issue Statement

Approval of a [resolution](#) allowing the City of Darien to perform maintenance and emergency work on City owned infrastructure on State of Illinois Highway System, for a period May 1, 2021 through April 30, 2023.

Background/History

The Illinois Department of Transportation mandates that a surety bond is secured for construction activity on all State owned Highways. Frontage Roads are also considered a part of the highway system. The City owns and maintains infrastructure on sections of the Frontage Roads such as watermains, sidewalks and limited storm sewers. The resolution allows the City to perform construction maintenance activities without the need of a surety bond through said resolution. The City will continue to be required to submit permits for maintenance or emergency repairs of City owned infrastructure. The resolution is in effect for two years beginning May 1, 2021 through April 30, 2023.

Staff Recommendation

Staff recommends approval of this Resolution.

Alternate Consideration

As directed.

Decision Mode

This item will be placed on the March 1, 2021, City Council agenda for formal consideration.



RESOLUTION NO. _____

A RESOLUTION ALLOWING THE CITY OF DARIEN TO PERFORM MAINTENANCE AND EMERGENCY WORK ON CITY OWNED INFRASTRUCTURE ON STATE OF ILLINOIS HIGHWAY SYSTEM, FOR A PERIOD MAY 1, 2021 THROUGH APRIL 30, 2023

WHEREAS, the City of Darien, hereinafter referred to as MUNICIPALITY, located in the County of DuPage, State of Illinois, desires to undertake, in the years of May 1, 2021 through April 30, 2023, the location, construction, operation and maintenance of driveways and street returns, watermains, sanitary and storms sewers, street lights, traffic signals, sidewalk, landscaping etc., on State highways, within said MUNICIPALITY, which by law and/or agreement come under the jurisdiction and control the Department of Transportation of the State of Illinois hereinafter referred to as Department, and,

WHEREAS, an individual working permit must be obtained from the Department prior to any of the aforesaid installations being constructed either by the MUNICIPALITY or by a private person or firm under contract and supervision of the MUNICIPALITY.

BE IT RESOLVED BY THE CITY COUNCIL OF THE CITY OF DARIEN, DU PAGE COUNTY, ILLINOIS, as follows:

SECTION 1: That MUNICIPALITY hereby pledges its good faith and guarantees that all work shall be performed in accordance with conditions of the permit to be granted by the Department, and to hold the State of Illinois harmless during the prosecution of such work, and assume all liability for damages to person or property due to accident or otherwise by reason of the work which it to be performed under the provision of said permit.

SECTION 2: That all authorized officials of the MUNICIPALITY are hereby instructed and authorized to sign said working permit on behalf of the MUNICIPALITY.

SECTION 3: This Resolution shall be in full force and effect from and after its passage and approval as provided by law.

PASSED AND APPROVED BY THE CITY COUNCIL OF THE CITY OF DARIEN, DU PAGE COUNTY, ILLINOIS, this 1st day of March 2021.

AYES: _____

NAYS: _____

ABSENT: _____

RESOLUTION NO. _____

**APPROVED BY THE MAYOR OF THE CITY OF DARIEN, DU PAGE COUNTY,
ILLINOIS, this 1st day of March, 2021.**

JOSEPH MARCHESE, MAYOR

ATTEST:

JOANNE E. RAGONA, CITY CLERK

APPROVED AS TO FORM

CITY ATTORNEY

AGENDA MEMO
Municipal Services Committee
February 22, 2021

ISSUE STATEMENT

A [resolution](#) accepting the unit price proposal for analytical soil testing fees from Clean Soils Consulting, LLC at the proposed unit prices for certain waste for a period of May 1, 2021 through April 30, 2022.

BACKGROUND

During the year, the department generates excavated materials from various Public Works projects, such as water main breaks, valve and hydrant replacements, landscape restorations and ditching projects. On July 30, 2011, Public Act 96-1416 Clean Construction or Demolition Debris (CCDD), became law. The law required the Illinois EPA to propose rules to establish technical requirements for CCDD facilities; set operating standards for uncontaminated soil fill operations; and develop standards for the maximum allowable concentrations of chemical constituents in uncontaminated soil generated during construction or demolition activities and used as fill material.

The law affects owners and operators of CCDD facilities and uncontaminated soil fill operations as well as governmental entities, road builders, landscapers, and other contractors and excavators that deliver CCDD or uncontaminated soil generated from construction or demolition activities to CCDD facilities and uncontaminated soil fill operations.

Staff requested competitive quotes for the required analytical testing services and received two (2) competitive quote (see [Attachment A](#)). The lowest bid was provided by Clean Soils Consulting, LLC. The pricing is to be held in place from May 1, 2021 to April 30, 2022.

The expenditure would come from the Water, Street and Capital accounts, depending on the specific project generating the waste. The total estimated costs for all maintenance and budgetary programs for this item are \$26,000.00.

STAFF RECOMMENDATION

Staff recommends accepting the unit price proposal for analytical soil testing fees from Clean Soils Consulting, LLC at the proposed unit prices.

ALTERNATE CONSIDERATION

As directed by the Municipal Services Committee.

DECISION MODE

This item will be placed on the March 1, 2021 City Council agenda for formal approval.

2021 City of Darien Analytical Soil Testing

	Testing Service Corporation		Clean Soils Consulting	
	Unit Cost	Unit Cost	Unit Cost	
Coordinate with our landfill facility and complete a project or address environmental site evaluation for analytical testing and provide a recommendation report for City construction material disposal	Each	\$ 525.00	\$ 240.00	
Stockpile or site sample collection, including travel to site and transport sample to laboratory. 4 hour Maximum per visit	Hour	\$ 130.00	\$ 84.00	Typically site time is 3 to 4 hours
Use of PID Instrument for Screening Soils	Each	\$ 50.00	\$ 84.00	
Compare testing results to IEPA tier one remediation objectives in tabular format, if objectives meet clean fill results provide a licensed professional engineer stamped LPC-663 with summary report describing sampling procedures followed and results of analytical testing.	Each	\$ 525.00	\$ 750.00	
If results are found to be contaminated recommend and coordinate with appropriate landfill dump facility to obtain non-special or special waste permit for disposal.	Each	\$ 325.00	\$ 240.00	*Does not include additional analytical testing
ANALYTICAL TEST				
VOCs	Each	\$ 162.00	\$ 156.00	
SVOCs	Each	\$ 270.00	\$ 260.00	
PNA's	Each	\$ 135.00	\$ 132.00	
RCRA 8 Total metals	Each	\$ 113.00	\$ 110.00	
RCRA 8 TCLP metals	Each	\$ 203.00	\$ 185.00	
PH	Each	\$ 24.00	\$ 20.00	
Preserved vials for volatile testing	Each	\$ 15.00	\$ 16.00	
Pesticides/PCBs	Each	\$ 162.00	\$ 155.00	
Herbicides	Each	\$ 262.00	\$ 242.00	
BTEXs	Each	\$ 54.00	\$ 53.00	
EPA 351AC1100 Full Panel	Each	\$ 1,535.00	\$ 1,322.00	
Note analytical costs for 7 to 10 day turn around				**Analysis selected dependent on soil location and disposal facility. Additional testing may be required and testing requirements are subject to change
	TOTAL	\$ 4,490.00	\$ 4,049.00	



RESOLUTION NO. _____

A RESOLUTION ACCEPTING THE UNIT PRICE PROPOSAL FOR ANALYTICAL SOIL TESTING FEES FROM CLEAN SOILS CONSULTING, LLC AT THE PROPOSED UNIT PRICES FOR CERTAIN WASTE FOR A PERIOD OF MAY 1, 2021 THROUGH APRIL 30, 2022

BE IT RESOLVED BY THE CITY COUNCIL OF THE CITY OF DARIEN, DU PAGE COUNTY, ILLINOIS, as follows:

SECTION 1: The City Council of the City of Darien does hereby accept a proposal from Clean Soils Consulting, LLC for analytical soil testing fees per the unit price proposal for a period of May 1, 2021 through April 30, 2022, attached hereto as "**Exhibit A**" and is by this reference expressly incorporated hereto.

SECTION 2: This Resolution shall be in full force and effect from and after its passage and approval as provided by law.

PASSED BY THE CITY COUNCIL OF THE CITY OF DARIEN, DU PAGE COUNTY, ILLINOIS, this 1st day of March, 2021.

AYES: _____

NAYS: _____

ABSENT: _____

APPROVED BY THE MAYOR OF THE CITY OF DARIEN, DU PAGE COUNTY, ILLINOIS, this 1st day of March, 2021.

JOSEPH MARCHESE, MAYOR

ATTEST:

JOANNE E. RAGONA, CITY CLERK

APPROVED AS TO FORM:

CITY ATTORNEY

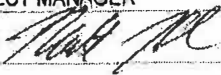
City of Darien is seeking quotes to provide testing services for construction material spoils generated from repair, maintenance, and installation of municipal utilities for a period January 1 2021 to December 31 2022.				PC21001-MH
			UNIT COST	
Coordinate with our landfill facility and complete a project or address environmental site evaluation for analytical testing and provide a recommendation report for City construction material disposal	EACH	\$	240	
Stockpile or site sample collection, including travel to site and transport sample to laboratory. 4 hour Maximum per visit	HOUR	\$	84	Typically site time is 3 to 4 hours.
Use of PID Instrument for Screening Soils	HOUR	\$	84	
Compare testing results to IEPA tier one remediation objectives in tabular format, if objectives meet clean fill results provide a licensed professional engineer stamped LPC-663 with a summary report describing sampling procedures followed and results of analytical testing.	EACH	\$	750	
If results are found to be contaminated <u>recommend</u> and <u>coordinate with</u> appropriate landfill dump facility to obtain non-special or special waste permit for disposal.	EACH	\$	240	* Does not include further additional analytical testing.
ANALYTICAL TEST				
VOCs	EACH	\$	156	
SVOCs	EACH	\$	260	
PNAs	EACH	\$	132	
RCRA 8 Total metals	EACH	\$	110	
RCRA 8 TCLP Metals	EACH	\$	185	
PH	EACH	\$	20	
Preserved Vials for volatile testing	EACH	\$	16	
Pesticides/PCBs	EACH	\$	155	
Herbicides	EACH	\$	242	
BTEXs	EACH	\$	53	
EPA 351AC1100 Full Panel	EACH	\$	1,322	
	TOTAL		4,049	** Analysis select dependent on soil location and disposal facility. Additional testing may be required and testing requirements are subject to change
Note analytical costs for 7 to 10 day turn around.				
COMPANY NAME: CLEAN SOILS CONSULTING LLC				
TITLE: PROJECT MANAGER				
SIGNATURE: 				

CSC
CLEAN SOILS CONSULTING

Matthew Halm

Project Manager

847-239-0879

matthew@ccddsoils.com

Services for the Environment ●●● www.ccddsoils.com

"We make Soils \$ense."



✉ P.O. Box #488 La Grange, IL
☎ 630-240-2955
📠 888-507-5750
🌐 www.ccdsoils.com

DATE: January 4, 2021

David Fell, Foreman
City of Darien
1041 S Frontage Road
Darien Illinois 60561

By Email: dfell@darienil.gov

Dear Mr. Fell:

RE: Proposal PC21001 – City of Darien Construction Material Spoils Testing for 2021 - 22

Thank you for your consideration of the services required for sampling, analysis and preparation of forms for continuation of your clean soils program. Clean Soils Consulting is uniquely qualified to assist you with this program. We work with a number of Illinois municipalities, provide compliance assistance to four working CCDD facilities, and have completed hundreds of LPC forms over the past ten years. We are members of both the UCA and IAAP, two organizations that are dedicated to development of professional standards for the industry and are active in the monitoring of developments concerning clean soils. Attached you will find our pricing for the services requested on the form required. There are several clarifications that we would make with regard to our pricing

Coordination with our landfill facility...for City construction material disposal.

The rate offered is for the technical assistance required to obtain either the appropriate LPC form for CCDD disposal or the waste disposal profile for landfill disposal. The rate does not include sampling or analysis for either profile as these items are covered by other bid items.

Stockpile or site sample collection.

The rate offered is a per hour rate during standard hours for an Environmental Professional with a properly calibrated photo-ionization detector (PID) for field screening of soils. The hourly rate is subject to a (4) four hour minimum. Analysis of the soil is not included in the rate offered as it is covered by other line items in our proposal.

Use of PID for Screening Soils.

The rate offered is a per hour rate during standard business hours for an EP with a properly calibrated PID for field screening of soils. The hourly rate is subject to a (2) two hour minimum. Analysis of soil is not included in the rate offered as it is covered by other line items in our proposal. If the line item that





P.O. Box #488 La Grange, IL

630-240-2955

888-507-5750

www.cddsoils.com

you are requesting pricing for does not include our labor, please let us know and we can revise this line item in our offer to you.

Compare testing results to IEPA...testing.

Our pricing includes review of the analytical data, comparison of the data to the MAC Table standards for disposal of soil at an area CCDD facility in an MSA excluding Chicago, preparation of the LPC-663 form signed and stamped by an Illinois licensed PE or PG, and a description of the sampling procedures followed. Sampling and analysis are covered by other bid items, and are not included in the rate offered.

If results are found to be contaminated...for disposal

Coordination of landfill disposal including preparation of waste disposal documents for the Owner's signature.

Analysis of the soil would be subject to the waste disposal analysis required by the landfill selected by the City for disposal of non-conforming materials. Sampling and analysis of the soil is covered by other bid items, and is not included in the price provided for this bid item.

Analytical Testing

Rates are based upon Standard Laboratory turnaround of 7 - 10 business days after the date of sampling.

The actual analysis required to complete the LPC-663 will be determined during our discussions with the receiving facility prior to completion of the analysis.

Price Schedule Notes / Explanations

Rates for services provided outside of standard business hours of 0700 – 1500 will be negotiated prior to performance of these services.





Pricing provided assumes that we have clear access to the site and can move around the perimeter freely.

Pricing includes our standard certificate of insurance. If additional insurance limits are required, our estimate would be increased by the additional cost + 15%.

Pricing does not include compliance with any site-specific health and safety provisions beyond our standard protocols (Modified Level D personal protective gear; all personnel are OSHA trained Hazwopers).

Pricing provided does not include any City permit fees, licenses, sales, use or other applicable taxes, if any, or the time required to obtain them.



 P.O. Box #488 La Grange, IL
 630-240-2955
 888-507-5750
 www.cddsoils.com

Additional services can be supplied on a time and material basis, as those services are identified.

The timing of delivery of the final work product is our best estimate of the time required. Delays are possible due to both the delivery of the independent analysis and the time required to review the project.

Our proposal is subject to the following additional terms and conditions:

Our fee is earned at the time of performance of the work, and is not predicated upon any determination of the results obtained.

Any additional services performed at the request of the customer will be provided and invoiced based on the services requested.

Pricing is fixed for the 2-year period requested in consideration of the contractual commitment made by each party. If you need rates for differing periods of time, whether shorter or longer, the quoted rates may be different.

The pricing offered is good through February 28, 2021 for work completed between that date and December 31, 2022.

CSC standard terms and conditions (T&Cs) shall apply to this work. Your signed acceptance of this proposal, issuance of your purchase order, or payment of the invoice tendered constitutes your acceptance of these T&Cs.

This proposal, including standard terms and conditions is 5 pages. Please sign and return one copy of the proposal to us if the pricing and scope of work are acceptable to you. By signing this agreement, you agree that you have the authority to bind the Customer to the pricing offered and the terms of this agreement.

If you have questions or concerns, please contact me at 847-239-0879 or at this email address.

We appreciate your consideration of our proposal. We look forward to the opportunity to be of service!

Sincerely,

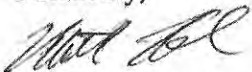

Matthew Halm
Clean Soils Consulting LLC

Customer Acceptance:

BY: _____

DATE: _____



AGENDA MEMO
Municipal Services Committee
February 22, 2021

ISSUE STATEMENT

Preliminary approval of a [resolution](#) for the purchase, removal and installation of 33 Street Lights by Rag's Electric, Inc. within the Woodland Subdivision at a cost not to exceed \$71,200.

BACKGROUND/HISTORY

The Woodlands Subdivision was constructed in the mid to late 1980's with limited dedicated roadways and parkways. The lighting adjacent to Tall Pines Drive and Bavarian Lane are the only dedicated roadways within the subdivision. The existing street lights are approximately 36 years in age and require removal and replacement due to rust and parts that are no longer available, see pictures labeled as [Attachment A](#). The Woodlands Home Owners Association owns and maintains 5 street lights. Those were replaced approximately 4 years ago. The street lighting was purchased by the HOA and installed by Rag's Electric, Inc. unfortunately that specific style has been discontinued.

The subdivision is very unique with many various over story trees and existing custom street lights. The HOA President requested that the City not utilize our standard 25 foot poles consisting of concrete or aluminum and further requested to match the existing or match the street lights installed by the HOA. Staff had informed the HOA President that the City would review costs compared to the City's standards for any potential cost share. See [Attachment B](#).

The Street Lighting contract has the following provision that would allow the City's awarded vendor, Rags Electric, to purchase the products required with a permitted markup.

G. BASIS OF PAYMENT:

Payment for "Street Lighting System Maintenance" shall be paid for as follows:

Should materials or parts other than lamps as specified above or fuse kits, (fuse kits include fuse holder, fuse, wire nuts, and/or heat shrink tape and/or electrical tape) be required to affect repairs or replacements to the "Street Lighting Systems", the Contractor shall furnish such parts and will receive the actual cost of the materials and parts, to which a maximum of fifteen percent (15%) shall be added.

The vendor's unit cost per street light is \$1,431.11 and the allowed markup is \$214.67 per unit for a total cost of \$7,084.11. Staff negotiated with Rag's Electric, Inc. to reduce the markup to 10% for a revised markup of \$143.11 per unit for a total cost of \$4,722.63, see Cost Summary Sheet labeled as [Exhibit A](#).

Upon review, the unit cost of the non-standard street light pole with installation is estimated at a not to exceed \$2,239.95. The cost of a City standard aluminum street light as per the FY2021/22 contract is \$4,160 and includes a foundation. The proposed street lights will not require new foundations. The vendor will be responsible to order, delivery, assemble and install 33, LH-49-LED-MT-PT-RSA-11-412-black light poles. The vendor will remove the existing poles and dispose of at the Public Works facility metal dumpster.

The 2021-22 Budget calls out for the funding for the Street Light Program from the following line items:

ACCOUNT NUMBER	ACCOUNT DESCRIPTION	FY 21/22 BUDGET
25-35-4390	WOODLAND STREET LIGHT REMOVAL AND REPLACEMENT	\$ 71,200

STAFF RECOMMENDATION

The Staff approval of a **resolution** for the purchase, removal and installation of 33 Street Lights by Rags Electric, Inc. within the Woodland Subdivision at a cost not to exceed 71,200.

ALTERNATE CONSIDERATION

As directed by the Municipal Services Committee.

DECISION MODE

This item will be placed on the City Council agenda for formal consideration at the March 1, 2021, City Council meeting, and pending budget consideration.















Dan Gombac

From: Kris Throm
Sent: Wednesday, January 8, 2020 1:10 PM
To: Dan Gombac
Subject: FW: Woodlands Streetlights-R&R-Clarification

FYI Just talked to Pat and he said he should be sending over the specs shortly

Thanks,

Kris Throm

City of Darien Municipal Services
Superintendent
(630) 514-3453

To receive important information from the City of Darien sign up for our electronic newsletter:

DARIEN DIRECT CONNECT

Follow the link below and subscribing is simple! <http://www.darien.il.us/Reference-Desk/DirectConnect.aspx>

From: Prendergast, Adam <Adam.P.Prendergast@amexgbt.com>
Sent: Wednesday, January 8, 2020 12:18 PM
To: Dan Gombac <dgombac@darienil.gov>
Cc: Laura Sneed <lsneed@elitemgt.net>; Kris Throm <kthrom@darienil.gov>; Rag's Electric, Inc. <ragselectric@aol.com>; Tom Belczak <tblczak@darienil.gov>; Joe Marchese <jmarchese@darienil.gov>; Bryon Vana <bvana@darienil.gov>; Regina Kokkinis <rkokkinis@darienil.gov>; Brook Whitebread <brookwhitebread@yahoo.com>; Richard Koopman <rnkoopman@me.com>
Subject: RE: Woodlands Streetlights-R&R-Clarification

Hi Dan,

Happy New Year. Just want to follow up with you from my question below for clarification. I appreciate your time, and response.

Best Regards,

From: Prendergast, Adam
Sent: Tuesday, December 17, 2019 2:24 PM
To: Dan Gombac <dgombac@darienil.gov>
Cc: Laura Sneed <lsneed@elitemgt.net>; Kris Throm <kthrom@darienil.gov>; Rag's Electric, Inc. <ragselectric@aol.com>; Tom Belczak <tblczak@darienil.gov>; Joe Marchese <jmarchese@darienil.gov>; Bryon Vana <bvana@darienil.gov>; Regina Kokkinis <rkokkinis@darienil.gov>; Brook Whitebread <brookwhitebread@yahoo.com>; Richard Koopman <rnkoopman@me.com>
Subject: RE: Woodlands Streetlights-R&R-Clarification

Thank you for the clarification. Option #2 "decorative light poles" is in the best interest of the Association. Please begin evaluating the cost.

Best Regards,
Adam

From: Dan Gombac [<mailto:dgombac@darienil.gov>]
Sent: Tuesday, December 17, 2019 2:16 PM
To: Prendergast, Adam <Adam.P.Prendergast@amexgbt.com>
Cc: Laura Sneed <lsneed@elitemgt.net>; Kris Throm <kthrom@darienil.gov>; Rag's Electric, Inc. <ragselectric@aol.com>; Tom Belczak <tbelczak@darienil.gov>; Joe Marchese <jmarchese@darienil.gov>; Bryon Vana <bvana@darienil.gov>; Regina Kokkinis <rkokkinis@darienil.gov>; Brook Whitebread <brookewhitebread@yahoo.com>; Richard Koopman <rnkoopman@me.com>
Subject: RE: Woodlands Streetlights-R&R-Clarification

CAUTION: This email originated from outside the organization. Do not click links or open attachments unless you recognize the sender and expect that the content is safe.

Regarding your statement below, I wanted to clarify:

1. Standard-25-foot aluminum poles with led mast arms



2. **Non Standard-Decorative Light poles-Pending cost, participation of the non-standard may be required from the**



Assoc.

Daniel Gombac
Director of Municipal Services
630-353-8106

To receive important information from the City of Darien sign up for our electronic newsletter:

DARIEN DIRECT CONNECT

Follow the link and subscribing is simple!

<http://www.darien.il.us/Reference-Desk/DirectConnect.aspx>

From: Prendergast, Adam <Adam.P.Prendergast@amexgbt.com>

Sent: Tuesday, December 17, 2019 10:24 AM

To: Dan Gombac <dgombac@darienil.gov>

Cc: Laura Sneed <lsneed@elitemgt.net>; Kris Throm <kthrom@darienil.gov>; Rag's Electric, Inc. <ragselectric@aol.com>;

Tom Beiczak <tbelczak@darienil.gov>; Joe Marchese <jmarchese@darienil.gov>; Bryon Vana <bvana@darienil.gov>;

Regina Kokkinis <rkokkinis@darienil.gov>; Brook Whitebread <brookwhitebread@yahoo.com>; Richard Koopman <rnkoopman@me.com>

Subject: RE: Woodlands Streetlights-R&R

Hi Dan,

Thank you for your response. Replacing with Non Standard-Decorative street lamps is not an option, so I would remove

that from consideration. Regarding "Standard-25-foot aluminum poles with led mast arms". Is that a like-for-like replacement with what we have in place now?

When is your upcoming budget meeting and is the public available to attend?

Best Regards,
Adam

From: Dan Gombac [<mailto:dgombac@darienil.gov>]
Sent: Tuesday, December 17, 2019 9:44 AM
To: Prendergast, Adam <Adam.P.Prendergast@amexgbt.com>
Cc: Laura Sneed <lsneed@elitemgt.net>; Kris Throm <kthrom@darienil.gov>; Rag's Electric, Inc. <ragselectric@aol.com>; Tom Belczak <tbelczak@darienil.gov>; Joe Marchese <jmarchese@darienil.gov>; Bryon Vana <bvana@darienil.gov>; Regina Kokkinis <rkokkinis@darienil.gov>
Subject: RE: Woodlands Streetlights-R&R

CAUTION: This email originated from outside the organization. Do not click links or open attachments unless you recognize the sender and expect that the content is safe.

Good morning Adam,

I am in receipt of your telephone message from yesterday regarding the street lights. As per your message you are requesting a meeting with Mayor Joe Marchese, Alderman Tom Belczak, and Staff, regarding your frustration with the replacement of the existing street lights on Tall Pines. The City Staff has been in contact with Ms. Sneed regarding the replacement of all the street lights on Tall Pines and we are currently assembling a pricing schedule to replace the lights for our upcoming budget, with one of the following options:

1. Standard-25-foot aluminum poles with led mast arms
2. Non Standard-Decorative Light poles-Pending cost, participation of the non-standard may be required from the Assoc.

At this time, I do not see a need for a meeting and will keep Ms. Sneed, and yourself updated, regarding the costs and budget process.

Sincerely,

Daniel Gombac
Director of Municipal Services
630-353-8106

To receive important information from the City of Darien sign up for our electronic newsletter:

DARIEN DIRECT CONNECT

Follow the link and subscribing is simple!

<http://www.darien.il.us/Reference-Desk/DirectConnect.aspx>

From: Dan Gombac <dgombac@darienil.gov>
Sent: Wednesday, December 11, 2019 11:39 AM
To: dgombac@darienil.gov
Subject: Fwd: Woodlands Streetlights

Begin forwarded message:

From: "Prendergast, Adam" <Adam.P.Prendergast@amexgbt.com>
Date: December 10, 2019 at 8:03:25 PM CST
To: "Dgombac@darienil.gov" <Dgombac@darienil.gov>
Subject: Woodlands Streetlights

Dan,

I am the President of the Woodlands HOA. Can you please advise when the street lights will be replaced at the Woodlands Subdivision? It's been 34 years since they've been installed, and they are overdue for replacement. They are rotting, with wires hanging out.

How can we work together to make this happen? I look forward to your response.

Best Regards,
Adam Prendergast

Notice: American Express Global Business Travel ("GBT") is a joint venture that is not wholly-owned by American Express Company or any of its subsidiaries ("American Express"). All trademarks and logos of American Express are used under limited license.

Avertissement : American Express Global Business Travel (« GBT ») est une joint-venture qui n'est pas détenue à 100 % par American Express Company ni par l'une de ses filiales (« American Express »). Tous les logos et marques commerciales d'American Express sont soumis à une licence limitée.

**Woodlands of Darien
Private Homeowner Association**

August 29, 2019

To: The City of Darien

From: The Woodlands of Darien Private Homeowners Association

RE: Village Street Lights on Tall Pine and Bavarian Circle

Hello,

The Woodlands of Darien Private Homeowners Association is requesting the City of Darien to assess the street lights along Tall Pine and Bavarian Circle; pictures provided. Since they belong to the City we are hoping you will consider a project for repair and/or replacement in the near future. Your consideration is appreciated.

Regards,

The Woodlands of Darien Board of Directors

PO BOX 628
WESTERN SPRINGS, IL 60558
WWW.ELITMGT.NET
DIRECT: (708) 352-2870
FAX: (708) 352-2871
INFO@ELITMGT.NET

RESOLUTION NO. _____

PRELIMINARY APPROVAL OF A RESOLUTION FOR THE PURCHASE, REMOVAL AND INSTALLATION OF 33 STREET LIGHTS BY RAG'S ELECTRIC, INC. WITHIN THE WOODLAND SUBDIVISION AT A COST NOT TO EXCEED \$71,200

BE IT RESOLVED BY THE CITY COUNCIL OF THE CITY OF DARIEN, DU PAGE COUNTY, ILLINOIS, as follows:

SECTION 1: The City Council of the City of Darien does hereby accept a preliminary approval of a resolution for the purchase, removal and installation of 33 Street Lights by Rag's Electric, Inc. within the Woodland Subdivision at a cost not to exceed \$71,200, attached hereto as "**Exhibit A**" and is by this reference expressly incorporated hereto.

SECTION 2: This Resolution shall be in full force and effect from and after its passage and approval as provided by law.

PASSED BY THE CITY COUNCIL OF THE CITY OF DARIEN, DU PAGE COUNTY, ILLINOIS, this 1st day of March, 2021.

AYES: _____

NAYS: _____

ABSENT: _____

APPROVED BY THE MAYOR OF THE CITY OF DARIEN, DU PAGE COUNTY, ILLINOIS, this 1st day of March, 2021.

JOSEPH MARCHESE, MAYOR

ATTEST:

JOANNE E. RAGONA, CITY CLERK

APPROVED AS TO FORM:

CITY ATTORNEY

JOB LOCATION

Woodlands Street Lighting R&R
LH-49-LED-MT-PT-RSA-11-412-Black light poles

DESCRIPTION	QUANTITY	UNIT	UNIT PRICE	TOTAL COST	NO OF LIGHTS INSTALLED PER DAY	HOURLY COST PER MAN	NO OF HOURS PER DAY PER 2 MEN	LABOR RATE PER DAY	NO OF DAYS TO COMPLETE	TOTAL COST FOR LABOR	TOTAL NO OF LABOR HOURS ESTIMATED
STREETLIGHTS	33	EACH	\$ 1,431.11	\$ 47,226.63	4.5	\$ 131.20	16	\$ 2,099.20	7.333333333	\$ 15,394.13	117.3333333
STREETLIGHT VENDOR MARKUP 10% NEGOTIATED FROM 15 % AS PER CONTRACT	33	EACH	\$ 143.11	\$ 4,722.63	EQUIPMENT	EQUIPMENT COST PER HR	HOURS PER DAY	EQUIPMENT COST PER DAY	NO OF DAYS TO REQUIRED	TOTAL COST FOR EQUIPMENT	TOTAL NO OF EQUIPMENT HOURS ESTIMATED
REMOVE AND INSTALL STREET LIGHTS	181.3333333	HOURLY	\$ 105.76	\$ 19,177.81	BUCKET TRUCK	\$ 53.30	8	\$ 426.40	8	\$ 3,411.20	64
MISCELLANEOUS					TOTAL LABOR AND EQUIPMENT COST					\$ 18,805.33	
TOP SOIL-MATERIAL	5	CUBIC YARD	\$ 16.00	\$ 80.00	COST PER LIGHT					\$ 569.86	
TOTAL LENGTH (FT)=	100				TOTAL NO OF LABOR AND EQUIPMENT HOURS ESTIMATED						181.3333333
WIDTH (FT)=	5				NO OF LIGHTS						33
AREA (CY)=	5				COST PER LIGHT					\$ 103.71	\$ 105.76
TOP SOIL-INSTALLED	5	CUBIC YARD	\$ 32.00	\$ 160.00	MATH CHECK						\$ 19,177.81
TOTAL LENGTH (FT)=	100				STREET LIGHT COSTS WITH MARKUP						\$ 51,949.26
WIDTH (FT)=	5				TOTAL COST PER STREET LIGHT WITH INSTALL						\$ 71,127.07
AREA (CY)=	5				MISC						\$ 1,240.00
SEED AND STRAW	1	LS	\$ 1,000.00	\$ 1,000.00	UNIT COST PER STREET LIGHT WITH INSTALL						\$ 2,192.94
SOD-INSTALLED	0	SQUARE YARD	\$ 8.50	\$ -							
TOTAL LENGTH (FT)=	0										
WIDTH (FT)=	0										
AREA (SF)=	0										
TOTAL COST				\$ 72,367.07							

From: pdurkin@ragselectric.com
To: [Dan Gombac](#)
Cc: [Regina Kokkinis](#)
Subject: RE: Re: Woodlands Poles
Date: Thursday, February 11, 2021 1:07:28 PM

Yes, Rag's agrees to the 10% markup

Thanks

Pat Durkin

Rag's Electric

(773)619-7640 = Cell

(630)739-RAGS(7247) = Office

----- Original Message -----

Subject: RE: Re: Woodlands Poles

From: "Dan Gombac" <dgombac@darienil.gov>

Date: 2/11/21 11:20 am

To: "pdurkin@ragselectric.com" <pdurkin@ragselectric.com>

Cc: "Regina Kokkinis" <rkokkinis@darienil.gov>

Good morning Pat,

As a follow up per our conversation this morning we are in agreement that a 10% markup will be utilized versus the contract stated 15%.

Please confirm.

Sincerely,

Daniel Gombac

Director of Municipal Services

630-353-8106

To receive important information from the City of Darien sign up for our electronic newsletter:

CATALOG NUMBER: LH-49-LED-MT-PT-RSA-11-412-XX

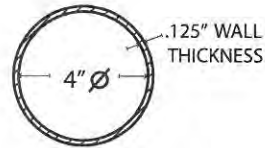
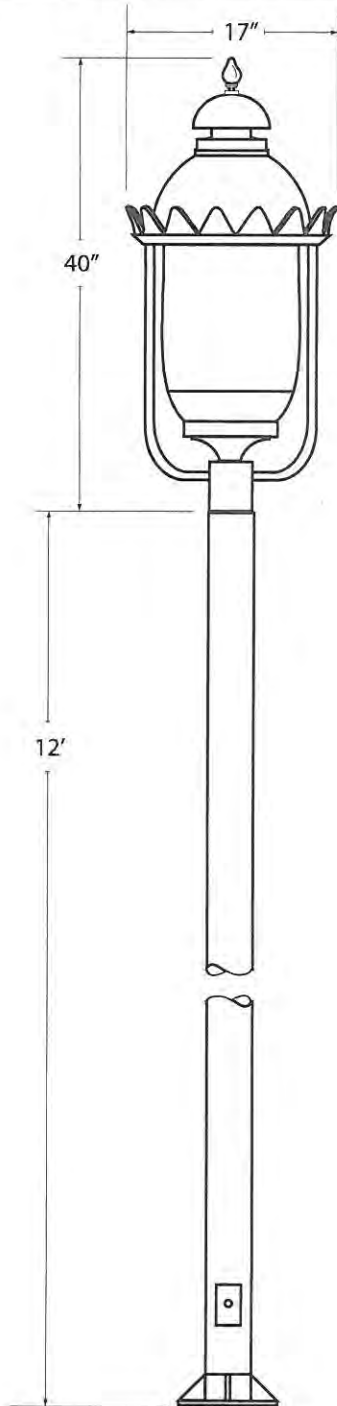

SHAFT CROSS SECTION

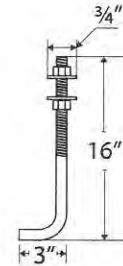

ANCHOR BOLTS

Anchor bolts are fabricated from hot rolled steel bar with minimum yield strength of 50,000 psi. These are hot dip galvanized in accordance to ASTM-A-153.

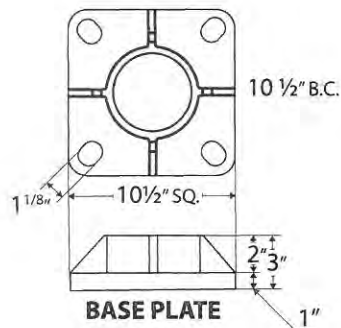

BASE PLATE

FIXTURE SPECIFICATIONS

Housing:	Corrosion resistant, cast A356 aluminum alloy, .188" min. wall thickness. White top.
LED:	49 Watts. Multi-Tap.
Lens:	Injection molded Polycarbonate.
Electrical:	All electrical components are UL approved.
Pole:	Round Straight Aluminum. Fabricated from 6063 extruded tubing, heat treated to produce a T6 temper. The anchor base shall be cast from a 356 alloy aluminum heat treated to a T6 condition. The base telescopes and pole shaft are circumferentially welded top and bottom.
Finish:	Polyester powder fuse coating. (Specify Color).

LED ENGINE INFORMATION

LUMINOUS FLUX	6000
WATTAGE	49
COLOR TEMPERATURE	4000K
CRI	>77
MILLIAMPS	700
OVERHEATING PROTECTION	YES
OPERATING POSITION	UNIVERSAL
AVERAGE LIFETIME 10% FAILURE	50000 HOURS
DIODE MANUFACTURER	PHILIPS LUXEON REBEL
LUMEN MAINTENANCE AT END OF LIFE	70%
INPUT VOLTAGE	120-277



PT - POST TOP



PACIFIC LIGHTING & STANDARDS COMPANY
LYNWOOD, CA
EST. 1984

SALES PERSON: CHARLES MUÑOZ	DATE: 6/3/16	CATALOG NUMBER: LH-49-LED-MT-PT-RSA-11-412-XX
DRAWN BY: M. ALATORRE		PROJECT NAME: THE WOODLANDS
CHECKED:		CUSTOMER: PETER DUFFECY
REVISION:		
APPROVED:		
TYPE:	SCALE: NONE	PAGE 1 OF 1

AGENDA MEMO
Municipal Services Committee
February 22, 2021

ISSUE STATEMENT

Preliminary approval of a [resolution](#) authorizing the Mayor and City Clerk to extend the Roadside Ditch Maintenance contract unit prices between the City of Darien and Scorpio Construction Corporation as it relates to the 67th Street geometrical roadway reconfiguration, 67th Street and Clarendon Hills Road, for the removal and replacement of storm sewer pipes, structures and grading in an amount not to exceed \$40,000.

BACKGROUND

67th St – Clarendon Hills Rd to Cass Avenue-Geometrical Configuration Storm Sewer Labor

Please recall, the proposed project was scheduled for last year and due to the pandemic was postponed. Scorpio Construction was the January 21, 2019, City Council awarded vendor for the Neighborhood Ditch Projects, attached and labeled as the [Attachment A](#), and included 67th Street as well as various others. Scorpio was to complete the work as, Additional Work, through the 67th Street Neighborhood Ditch Project pricing schedule.

Staff has recently reached out to Scorpio Construction and inquired whether they would honor the unit prices from the 2019 contract as it relates to the 67th Street project. Scorpio Construction Corporation has agreed to hold their unit pricing with the exception of a mobilization cost of \$3,500 (\$1,750 equipment in and \$1,750 equipment out). Staff is in agreement with the mobilization cost as a standard in the industry as it relates to mobilizing machinery and equipment.

The proposed contract with Scorpio Construction Corporation includes the following:

- A. Removal and Placement of Pipes
- B. Removal and Placement of Inlets, Catch Basins and Grates
- C. Ditch Regrading

[Attachment B](#) pages 1-2 summarizes the total cost for the project and includes a detail on page 2 as it relates to the storm related work. The City will be purchasing the material for the vendor to be installed.

The proposed expenditure would be spent from the following account:

ACCOUNT NUMBER	ACCOUNT DESCRIPTION	FY 21/22 PROPOSED BUDGET	PROPOSED EXPENDITURE TO SCORPIO
25-35-4376	DITCH PROJECTS BASE BID 1 & 2	\$220,915.00	\$ 40,000

STAFF RECOMMENDATION

Preliminary approval of a resolution authorizing the Mayor and City Clerk to extend the Roadside Ditch Maintenance contract unit prices between the City of Darien and Scorpio Construction Corporation as it relates to the 67th Street geometrical roadway reconfiguration, 67th Street and Clarendon Hills Road, for the removal and replacement of storm sewer pipes, structures and grading in an amount not to exceed \$40,000.

ALTERNATE CONSIDERATION

As directed by the Municipal Services Committee.

DECISION MODE

This item will be placed on the March 1, 2021 City Council agenda, pending Budget consideration, for formal approval.

AGENDA MEMO
City Council
January 21, 2019

ISSUE STATEMENT

Preliminary approval of a **motion** authorizing the following Roadside Ditch Maintenance Projects:

BASE BID	Construction	Project Cost
1. Elm St – Clarendon Hills Rd to Route 83	\$ 304,650.00	\$ 721,190.00
2. Janet Ave – Clarendon Hills Rd to Route 83	\$ 191,300.00	\$ 565,600.00
Base Bid Total	\$ 495,950.00	\$ 1,286,790.00

And the following Alternate:

ALTERNATES-PENDING BUDGET DISCUSSIONS

A1. 67 th St – Clarendon Hills Rd to Cass Ave	\$ 868,000.00	\$ 1,700,000.00
--	---------------	-----------------

Preliminary approval of a resolution authorizing the Mayor and City Clerk to execute a contract for the 2019 Roadside Ditch Maintenance – Regrading Program between the City of Darien and Scorpio Construction Corporation for the layout and replacement of storm sewer pipes and structures and grading in an amount not to exceed \$495,950.

RESOLUTION**BACKGROUND**

The proposed are the FY 2019-20 neighborhood drainage projects:

	Construction	Project Cost
1. Elm St – Clarendon Hills Rd to Route 83	\$ 304,650.00	\$ 721,190.00
2. Janet Ave – Clarendon Hills Rd to Route 83	\$ 191,300.00	\$ 565,600.00
Base Bid Total	\$ 495,950.00	\$ 1,286,790.00

ALTERNATES-PENDING BUDGET DISCUSSIONS

A1. 67 th St – Clarendon Hills Rd to Cass Ave	\$ 868,000.00	\$ 1,700,000.00
--	---------------	-----------------

Total Base and Alternate Costs **\$ 2,986,790.00**

The following neighborhood drainage projects are Alternates and will be reviewed for the FY 2019-20 Budget:

67th St – Clarendon Hills Rd to Cass Avenue
Sawmill Creek – 74th Street to Janet Avenue-Removed

Residents adjacent to these projects have requested that the City address standing water in the ditches fronting their residences. The scope of work under the proposed contract would include the removal and replacement of culverts, removal and installation of inlets as required, ditch regrading, and bank stabilization and preparation for landscape restoration. All materials and outsourcing for landscaping, bituminous surface, concrete, testing, trucking and tipping and transfer fees are under separate agenda memos.

Below is a narrative of the projects:

Elm Street - Clarendon Hills Road to Route 83 is related to the deficient storm water ditch conveyance on Elm Street-Clarendon Hills Road to Route 83. The existing conditions on Elm Street within the southern and northern right of way do not allow for the conveyance of storm water to flow from the respective summits towards Eleanor Place and Elm Street. The proposed project would include the removal and replacement of deteriorated culverts, installation of inlets as required, the enclosure of ditches as necessary, and approximately 3600 lineal feet of ditch regrading. The project goal is to allow storm water to flow at the optimal level.

Janet Ave – Clarendon Hills Rd to Route 83 is related to the deficient storm water ditch conveyance on Janet Avenue from clarendon Hills Road to Route 83. Limited existing conditions on Janet Avenue within the northern and southern right of ways do not allow the conveyance of storm water to flow from Clarendon Hills Road and/or

Route 83 to mid-block tributaries. The proposed project would include the removal and replacement of deteriorated culverts, installation of inlets as required, the enclosure of ditches as necessary, and approximately 5600 lineal feet of ditch regrading. The project goal is to allow storm water to flow at the optimal level to the respective tributaries.

67th St – Clarendon Hills Rd to Cass Avenue is related to the deficient storm water ditch conveyance within the 67th Street, Clarendon Hills Road to Cass Ave corridor. The existing conditions on 67th Street within the northern and southern right of way do not allow the conveyance of storm water to flow from the respective various summits. The proposed project would include the removal and replacement of deteriorated culverts, installation of inlets as required, the enclosure of ditches as necessary, and approximately 11,000 lineal feet of ditch regrading. The projects has summits for storm water to be channeled to the appropriate intersecting street or basin. The project goal is to allow storm water to flow at the optimal level.

**The proposed project is an Alternate and is being considered for the FY 19-20 Budget should funding be available.*

Staff received one (1) sealed bid on December 19, 2018. See **Attachment A**. The bid tabulation includes two (2) base bids and two (2) alternatives. The sole bidder was Scorpio Construction Corporation. The final projects will be determined by the City Council upon Budget Hearings.

Attachment B summarizes the total cost for each project and includes materials, additional services and the proposed bid costs for the 2019 Neighborhood Drainage Program.

The proposed contract with Scorpio Construction Corporation includes the following:

- A. Field Layout
- B. Removal and Placement of Deteriorated Pipes
- C. Removal and Placement of Inlets, Catch Basins and Grates
- D. Ditch Regrading

Scorpio Construction Corporation has provided services for the ditching program in 2008, 2010 through 2016 with very satisfactory results.

The proposed expenditure would be spent from the following account:

ACCOUNT NUMBER	ACCOUNT DESCRIPTION	FY 19/20 PROPOSED BUDGET	PROPOSED EXPENDITURE TO SCORPIO	TOTAL PROJECT COST
25-35-4376	DITCH PROJECTS BASE BID 1 & 2	\$1,286,790.00	\$ 495,950.00	\$1,286,790.00
25-35-4376	DITCH PROJECTS ALTERNATE A1-67th ST.	\$1,700,000.00	\$ 868,000.00	\$1,700,000.00
TOTAL		\$2,986,790.00	\$1,363,950.00	\$2,986,790.00

COMMITTEE RECOMMENDATION

Municipal Services Committee recommends approval of the proposed contract with Scorpio Construction Corporation for the Base Bid Projects and the alternative bid, 67th street project, pending budget approval.

ALTERNATE CONSIDERATION

As directed by the City Council.

DECISION MODE

This item will be placed on a future City Council agenda, pending Budget consideration, for formal approval.

ITEM	UNIT	QUANTITY	BID PRICING	TOTAL COST
ROADWAY PAVING AND STRIPING				
EARTH EXCAVATION	CU YD	255	\$ 30.00	\$ 7,650.00
REMOVAL AND DISPOSAL OF UNSUITABLE MATERIAL	CU YD	250	\$ 30.00	\$ 7,500.00
FURNISHED EXCAVATION	CU YD	100	\$ 20.00	\$ 2,000.00
AGGREGATE SUBGRADE IMPROVEMENT	CU YD	250	\$ 30.00	\$ 7,500.00
BITUMINOUS MATERIALS (TACK COAT)	POUND	125	\$ 0.10	\$ 12.50
POLYMERIZED LEVELING BINDER (MACHINE METHOD), N50	TON	90	\$ 84.00	\$ 7,560.00
HOT-MIX ASPHALT SURFACE COURSE, MIX "D", N50	TON	215	\$ 64.00	\$ 13,760.00
HOT-MIX ASPHALT BINDER COURSE, IL-19.0, N50	TON	125	\$ 72.00	\$ 9,000.00
HOT-MIX ASPHALT SURFACE REMOVAL, 2.5"	SQ YD	1,100	\$ 2.88	\$ 3,168.00
CLASS D PATCHES, TYPE I, 6 INCH	SQ YD	700	\$ 30.00	\$ 21,000.00
CLASS D PATCHES, TYPE II, 6 INCH	SQ YD	240	\$ 30.00	\$ 7,200.00
CLASS D PATCHES, TYPE III, 6 INCH	SQ YD	120	\$ 30.00	\$ 3,600.00
CLASS D PATCHES, TYPE IV, 6 INCH	SQ YD	120	\$ 30.00	\$ 3,600.00
THERMOPLASTIC PAVEMENT MARKING - LETTERS AND SYMBOLS	SQ FT	40	\$ 5.25	\$ 210.00
THERMOPLASTIC PAVEMENT MARKING - LINE 4"	FOOT	815	\$ 0.81	\$ 660.15
THERMOPLASTIC PAVEMENT MARKING - LINE 6"	FOOT	140	\$ 1.31	\$ 183.40
THERMOPLASTIC PAVEMENT MARKING - LINE 12"	FOOT	60	\$ 2.62	\$ 157.20
THERMOPLASTIC PAVEMENT MARKING - LINE 24"	FOOT	30	\$ 5.25	\$ 157.50
STRUCTURES TO BE ADJUSTED	EACH	4	475	\$ 1,900.00
TOTAL ROAD WORK VALUE				\$ 96,818.75
CONCRETE RESTORATION				
PORTLAND CEMENT CONCRETE SIDEWALK 5 INCH	SQ FT	90	\$ 6.35	\$ 571.50
COMBINATION CONCRETE CURB AND GUTTER, SPECIAL	FOOT	975	\$ 23.00	\$ 22,425.00
TOTAL CONCRETE VALUE				\$ 22,996.50
LANDSCAPE RESTORATION				
TOPSOIL, FURNISH AND PLACE 6"	SQ YD	1,000	\$ 8.00	\$ 8,000.00
GRADING AND SHAPING DITCHES	FOOT	900	\$ 25.00	\$ 22,500.00
SEEDING, CLASS 1A	ACRE	0.25	\$ 20,000.00	\$ 5,000.00
EROSION CONTROL BLANKET	SQ YD	1,000	\$ 10.00	\$ 10,000.00
TOTAL LANDSCAPE RESTORATION VALUE				\$ 45,500.00
STORM SEWER REMOVAL AND REPLACEMENT				
STORM SEWER, 12" (WATER MAIN QUALITY)	FOOT	270	\$ 80.00	\$ 21,600.00
STORM SEWER REMOVAL, 12"	FOOT	200	\$ 10.00	\$ 2,000.00
INLETS, TYPE A, TYPE 8 GRATE	EACH	2	\$ 2,500.00	\$ 5,000.00
CATCH BASINS, 4'-DIAMETER, TYPE 8 GRATE	EACH	3	\$ 5,000.00	\$ 15,000.00
DRAINAGE STRUCTURE TO BE REMOVED	EACH	4	\$ 500.00	\$ 2,000.00
TOTAL STORM SEWER REMOVAL AND REPLACEMENT COST				\$ 45,600.00
CONSTRUCTION LAYOUT	L. SUM	1	\$ 10,000.00	\$ 10,000.00
TOTAL PROJECT COST				\$ 220,915.25

DESCRIPTION	ACCOUNT DESCRIPTION	FUND	FY21-22 BUDGET
ROADWAY PAVING AND STRIPING	STORM WATER/DITCH PROJECTS	03-60-4855	\$ 96,900.00
CONCRETE RESTORATION	CURBA ND GUTTER PROGRAM	25-35-4376	\$ 23,000.00
LANDSCAPE RESTORATION	67TH STREET STORM SEWER RELOCATION AND LANDSCAPE RESTORATION	25-35-4376	\$ 45,500.00
STORM SEWER REMOVAL AND REPLACEMENT	67TH STREET STORM SEWER RELOCATION AND LANDSCAPE RESTORATION	25-35-4376	\$ 45,600.00
CONSTRUCTION LAYOUT	67TH CONSTRUCTION LAYOUT	25-35-4376	\$ 10,000.00
TOTAL PROJECT COST			\$ 221,000.00

JOB LOCATION

67th Street Clarendon Hills Road to Cass Ave

DESCRIPTION	QUANTITY	UNIT	UNIT PRICE	TOTAL COST
12-inch Sdr26 2241	270	LINEAL FT	\$ 10.75	\$ 2,902.50
BEEHIVE GRATE NEENAH R-4340-B	4	EACH	\$ 139.32	\$ 557.28
4-FOOT MANHOLE WITH BOTTOM	3	EACH	\$ 1,000.00	\$ 3,000.00
STONE GRADE CA-7	114.54	TON	\$ 19.30	\$ 2,210.62
TOTAL LENGTH (FT)=	300			
WIDTH (FT)=	2.5			
AREA (SY)=	83			
DUMP FEES	29	PER LOAD	\$ 55.00	\$ 1,595.00
TOTAL LENGTH (FT)=	350			
WIDTH (FT)=	15			
AREA (CY)=	292			
TRUCKING	40	LOADS	\$ 82.00	\$ 3,280.00
SUB-TOTAL COST				\$ 13,545.40
MISC-BRICK/ ADJ RINGS,MORTAR,MASTIC	\$ 677.27	EACH	5% of Subtotal	\$ 677.27
SUB-TOTAL COST				\$ 14,222.67
CONTRACT EXCAVATION-DITCH AREA	24.00	HOURLY	\$ 500.00	\$ 12,000.00
CONTRACT EXCAVATION PER FOOT-REMOVAL OF PIPE-OR DRIVEWAYS	200.00	LINEAL FOOT	\$ 20.00	\$ 4,000.00
CONTRACT EXCAVATION PER FOOT-INSTALLATION OF PIPE-OR DRIVEWAYS	270.00	LINEAL FOOT	\$ 30.00	\$ 8,100.00
CONTRACT STRUCTURE REMOVAL	4.00	EACH	\$ 200.00	\$ 800.00
CONTRACT STRUCTURE INSTALL	5.00	EACH	\$ 550.00	\$ 2,750.00
2 TRAFFIC CONTROL CERTIFIED FLAGGERS	40	HOURLY	\$ 300.00	\$ 12,000.00
MOBILIZATION	1.00	LUMP SUM	\$ 3,500.00	\$ 3,500.00
OUTSOURCE COST				\$ 43,150.00
SUB TOTAL COST				\$ 57,372.67
CONTINGENCY	1	LUMP SUM	5%	\$ 2,868.63
TOTAL COST				\$ 60,241.30
TOTAL COST				\$ 60,241.30
DIFFERENCE				
TOTAL ESTIMATE-BUDGET				

RESOLUTION NO. _____

A RESOLUTION AUTHORIZING THE MAYOR AND CITY CLERK TO EXTEND THE ROADSIDE DITCH MAINTENANCE CONTRACT UNIT PRICES BETWEEN THE CITY OF DARIEN AND SCORPIO CONSTRUCTION CORPORATION AS IT RELATES TO THE 67TH STREET GEOMETRICAL ROADWAY RECONFIGURATION, 67TH STREET AND CLARENDON HILLS ROAD, FOR THE REMOVAL AND REPLACEMENT OF STORM SEWER PIPES, STRUCTURES AND GRADING IN AN AMOUNT NOT TO EXCEED \$40,000

BE IT RESOLVED BY THE CITY COUNCIL OF THE CITY OF DARIEN, DU PAGE COUNTY, ILLINOIS, as follows:

SECTION 1: The City Council of the City of Darien hereby authorizes the Mayor and City Clerk to extend the Roadside Ditch Maintenance contract unit prices between the City of Darien and Scorpio Construction Corporation as it relates to the 67th Street geometrical roadway reconfiguration, 67th Street and Clarendon Hills Road, for the removal and replacement of storm sewer pipes, structures and grading in an amount not to exceed \$40,000, a copy of which is attached hereto as "[Exhibit A](#)" and is by this reference expressly incorporated herein.

SECTION 3: This Resolution shall be in full force and effect from and after its passage and approval as provided by law.

PASSED BY THE CITY COUNCIL OF THE CITY OF DARIEN, DU PAGE COUNTY, ILLINOIS, this 1st day of March, 2021.

AYES: _____

NAYS: _____

ABSENT: _____

APPROVED BY THE MAYOR OF THE CITY OF DARIEN, DU PAGE COUNTY, ILLINOIS, this 1st day of March, 2021.

JOSEPH MARCHESE, MAYOR

ATTEST:

JOANNE E. RAGONA, CITY CLERK

APPROVED AS TO FORM:

CITY ATTORNEY

From: Dan Gombac
Sent: Thursday, February 11, 2021 10:20 AM
To: Bruno Rendina
Cc: Bryon Vana; Regina Kokkinis; Kris Throm
Subject: RE: 67th Street Realignment Project-Storm Sewer

Good morning Bruno,

The mobilization,(\$3,500, in \$1,750, out \$1,750) is reasonable and acceptable. Upon approval we will notify you to proceed.

Sincerely,

Daniel Gombac

Director of Municipal Services

630-353-8106

To receive important information from the City of Darien sign up for our electronic newsletter:

DARIEN DIRECT CONNECT

Follow the link and subscribing is simple!

<https://darien.il.us/reference-desk/directconnect-eneews>

From: Bruno Rendina <scorpioconst@yahoo.com>
Sent: Wednesday, February 10, 2021 4:23 PM
To: Dan Gombac <dgombac@darienil.gov>
Subject: Re: 67th Street Realignment Project-Storm Sewer

Good Day Dan,

We would like to let you know that Scorpio Construction Corp. will honor the 2019/2020 Ditching Project unit prices, for the work at the intersection of 67th street and Clarendon Hills Rd. Scorpio Construction is asking for an additional \$3,500 for mobilization cost. We look forward to work with you.

Sincerely,

Bruno Rendina
Scorpio Construction Corp.
103 Oswego Plains Dr.
Oswego, IL. 60543
630-554-0397

On Tuesday, February 9, 2021, 11:46:42 AM CST, Dan Gombac <dgombac@darienil.gov> wrote:

Good morning Bruno,

Alternate 1 - 67th Street - Clarendon Hills Road to Cass Ave

The proposed **Project 67th Street - Clarendon Hills Road to Cass Ave** is related to the deficient storm water ditch conveyance within the 67th Street, Clarendon Hills Road to Cass Ave corridor. The existing conditions on 67th Street within the northern and southern right of way do not allow the conveyance of storm water to flow from the respective various summits. The proposed project would include the removal and replacement of deteriorated culverts, installation of inlets as required, the enclosure of ditches as necessary, and approximately 11,000 lineal feet of ditch regrading. The projects has summits for storm water to be channeled to the appropriate intersecting street or basin. The project goal is to allow storm water to flow at the optimal level.

Please note: Pending drainage study results, performed by others, approximately 2,000 lineal feet of 36-42-inch High Density Polyethylene or Reinforced Concrete Pipe Class III may be utilized and is noted as an option below.

DESCRIPTION	QUANTITY	UNIT	UNIT PRICE	TOTAL COST
PIPE CULVERT REMOVAL	2000	LINEAL FOOT	20	40,000
STRUCTURE REMOVAL	25	EACH	200	5,000
PIPE/HDPE CULVERT INSTALLATION	4000	LINEAL FOOT	30	120,000
36-42 INCH CLASS III REINFORCED CONCRETE PIPE-OPTION A	2000	LINEAL FOOT	110	220,000
OR				
36-42 INCH HIGH DENSITY POLYETHYLENE PIPE-OPTION B	2000	LINEAL FOOT	60	120,000
4-6-INCH CORRUGATED PERFORATED UNDER DRAIN	1000	LINEAL FOOT	20	20,000
12 x 12 INLET BOXES	200	EACH	75	15,000
FLARED END SECTION-METAL	20	EACH	100	2,000
STORM SEWER STRUCTURE INSTALL	100	EACH	700	70,000
LAYOUT-JOB CONSULTATION	80	HOURLY	200	16,000
CERTIFIED FLAGGER 1	400	HOURLY	150	60,000
CERTIFIED FLAGGER 1	400	HOURLY	150	60,000
DITCHING-GRADING COSTS				
OPERATOR WITH GRAD-ALL OR RUBBER TRACK EXCAVATOR-OR TRACK EQUIPMENT LEAD FOREMAN AND 2-LABORERS	240	HOURLY	500	120,000
TOTAL COST PROJECT- 67th Street Clarendon Hills Road to Cass Ave				868,000

Alternate 1-Total Cost of Project 67th Street Clarendon Hills Road to Cass Ave in words:

EIGHT HUNDRED SIXTY EIGHT THOUSAND

**MINUTES
CITY OF DARIEN
MUNICIPAL SERVICES COMMITTEE MEETING
January 25, 2021**

PRESENT: Alderman Thomas Belczak -Chairman, Alderman Eric Gustafson,
Alderman Joseph Kenny, Mayor Joe Marchese, Dan Gombac – Director, Jordan
Yanke - Senior Planner, Elizabeth Lahey - Secretary

ABSENT: None

ESTABLISH QUORUM

Chairperson Thomas Belczak called the meeting to order at 7:00 p.m. This was a Zoom call and City Staff was present at City Hall Council Chambers, Darien, Illinois. Chairperson Belczak declared a quorum present.

NEW BUSINESS

- a. **Ordinance – Approval of a text amendment to Section 9-3-1 of the City Code adding restrictions regarding the idling of vehicles, specifically expanding the zoning districts in the City where property owners shall post “No Idling/per Darien City Code” signs.**

Mr. Dan Gombac, Director reported that at the March 2019 City Council meeting, the Council adopted a text amendment to regulate vehicle idling times as a way to reduce air pollution and conserve fuel. He reported that per the adopted Ordinance, a mandate for owners of property in any of the City’s B Zoning Districts to post “No Idling/per Darien City Code” signs were included.

Mr. Gombac reported that since the time of adoption, staff has been requested to expand the zoning districts subject to the mandate to include the Office Research and Light Industry (OR&I) Zoning District and the General Industrial (I-1) Zoning District.

There was some discussion regarding no idling in the B-2 District. Mr. Gombac reported that all B-2 Districts have complied and that signs are up.

There was no one else in the audience wishing to present public comment.

Alderman Kenny made a motion, and it was seconded by Alderman Gustafson to approve a text amendment to Section 9-3-1 of the City Code adding restrictions regarding the idling of vehicles, specifically expanding the zoning districts in the City where property owners shall post “No Idling/per Darien City Code” signs.

Upon voice vote, the MOTION CARRIED UNANIMOUSLY 3-0.

- b. Motion - Architectural and design guidelines for Commercial and Office developments. Per City Council direction, guidelines are recommended versus mandates, meaning the guidelines will not be implemented as a zoning code amendment or Comprehensive Plan update.**

Mr. Dan Gombac, Director reported that at the September 21, 2020 City Council meeting, the Council directed staff to develop an informational sheet containing recommended design guidelines for Commercial and Office developments. He reported that the Council directed staff to develop an Informational Sheet instead of proceeding with a zoning code amendment or Comprehensive Plan update to implement design guidelines throughout the City.

Mr. Gombac stated that staff provided a narrative and summary of comparable design standards in the packet. He stated that with the approval of the recent commercial building at 7532 S. Cass Avenue, which included an economic incentive for improved elevations, several members of Council requested that staff investigate if any similar and comparable communities have code requiring a minimum architectural and design standard for construction. He reported that staff compiled a spreadsheet [Attachment B] from similar and adjacent municipalities.

Mr. Jordan Yanke, Senior Planner reported that staff put together an information attachment [Attachment A] of what the City would like to see with redevelopment.

Alderman Gustafson suggested possibly looking at changing some of the standards.

Chairperson Belczak stated that the information provided spells out what the City is looking for and he would like to see how this works.

There was no one else in the audience wishing to present public comment.

Alderman Belczak made a motion, and it was seconded by Alderman Kenny to approve architectural and design guidelines for Commercial and Office developments. Per City Council direction, guidelines are recommended versus mandates, meaning the guidelines will not be implemented as a zoning code amendment or Comprehensive Plan update.

Upon voice vote, the MOTION CARRIED UNANIMOUSLY 3-0.

- c. Resolution – Approval awarding a contract to Homer Tree Care, Inc in an amount not to exceed \$147,000.00 for the City's 2021/22 Tree Trimming and Removal Program.**

Mr. Dan Gombac, Director reported that the proposed tree trimming program consists of trimming approximately 1,750 parkway trees, approximately 65 tree removals and stump grinding. He reported that the subdivisions to be trimmed: are Darien Club, Downers Fairview, Brookhaven Manor and Alison Court. He further reported that this year's program also includes contract pricing for the Private Property Tree Trimming Program to all the residents and that the program would allow residents to have their private property trees trimmed or removed and stump grinding at the resident's expense.

There was no one else in the audience wishing to present public comment.

Alderman Kenny made a motion, and it was seconded by Alderman Gustafson awarding a contract to Homer Tree Care, Inc in an amount not to exceed \$147,000.00 for the City's 2021/22 Tree Trimming and Removal Program.

Upon voice vote, the MOTION CARRIED UNANIMOUSLY 3-0.

- d. Resolution – Approval awarding a contract to Rag’s Electric, Inc., the 2021 Street Light Maintenance Contract beginning May 1, 2021 through April 30, 2022.**

Mr. Dan Gombac, Director reported that staff received four sealed bids for the 2021-22 Street Light Maintenance Contract. He reported that staff provided a bid tabulation, [Attachment A], for costs to repair streetlights, hourly rates for labor, equipment, and lamp costs. He further reported that the tabulation also included a pricing schedule for two additional option years, and that Rags Electric was not the lowest price for the subsequent years. He stated that upon the expiration of the proposed contract ending April 30, 2022, staff will review whether the contract should be rebid or further negotiated and forwarded for City Council approval.

There was no one else in the audience wishing to present public comment.

Alderman Belczak made a motion, and it was seconded by Alderman Gustafson awarding a contract to Rag’s Electric, Inc., the 2021 Street Light Maintenance Contract beginning May 1, 2021 through April 30, 2022.

Upon voice vote, the MOTION CARRIED UNANIMOUSLY 3-0.

- e. Resolution – Approval to authorize the Private Property Rear Yard Storm Water Management Assistance Projects.**

Mr. Dan Gombac, Director reported that throughout the year, the City receives complaints regarding drainage issues within the rear lot lines/easements. Tines/easements. He reported that the complaints are due to standing water that stems from active sump pumps, grading issues and mature landscaping and that the areas further stay saturated throughout the season, thereby making it difficult to mow and maintain these areas and further creates conditions for mosquito breeding.

Mr. Gombac reported that the City’s Private Property-Rear Yard Storm Water Management Assistance Policy allows residents, multifamily, commercial property owners, and the City to work together in resolving these nuisance ponding and drainage issues. He reported that Attachment A shows the costs, location, and reimbursement schedule.

There was no one else in the audience wishing to present public comment.

Alderman Belczak made a motion, and it was seconded by Alderman Gustafson approval of a Resolution to authorize the Private Property Rear Yard Storm Water Management Assistance Projects.

Upon voice vote, the MOTION CARRIED UNANIMOUSLY 3-0.

f. Resolution - Approval to extend a contract with Denler Inc. in an amount not to exceed \$221,250.00 for the 2021 Crack Fill Program.

Mr. Dan Gombac, Director reported that the FY 21/22 Budget includes funds for the 2021 Crack Fill Program. He reported that crack sealing is a routine maintenance treatment that significantly delays roadway deterioration and that the sealing material is applied into the cracks before they become too large and before the freeze-thaw cycles have an opportunity to shift the pavement and develop larger cracks and by doing this, the life of the road is extended, and maintenance costs are greatly reduced over time.

Mr. Gombac reported that in 2019 the City of Darien teamed up with local public agencies including Burr Ridge, Downers Grove, DuPage County, Elmhurst, Lombard, Villa Park, West Chicago, Wheaton, and Woodridge and solicited competitive bids, collectively. He reported that Attachment A are the bid results from the bid opening held by the Village of Woodridge on March 21, 2019.

Mr. Gombac reported that this would be the last extension of a three (3) year program.

He reported that crack filling was not done due to the COVID-19 pandemic.

There was no one else in the audience wishing to present public comment.

Alderman Belczak made a motion, and it was seconded by Alderman Gustafson approval of a Resolution to extend a contract with Denler Inc. in an amount not to exceed \$221,250.00 for the 2021 Crack Fill Program.

Upon voice vote, the MOTION CARRIED UNANIMOUSLY 3-0.

g. Resolution – Approving the services for a Code Enforcement Officer.

Mr. Dan Gombac, Director reported that Code Enforcement operations provides a framework for staff to provide code compliance in a manner which is clear and concise for residents, visitors, and businesses. He reported that the strategy of the department is now to shift focus to a more proactive versus reactive nature of code compliance and that the primary point person for Code Enforcement is the City Planner. Mr. Gombac reported that due to time constraints, staff does not have the ability to be proactive for code compliance and therefore recommending approval of a Code Enforcement Officer. He further reported that Attachment A provides the guidelines.

Mr. Gombac reported that staff works with the Community Service Officer and that staff is working on bringing in house adjudication.

Mr. Jordan Yanke, City Planner reported that it is difficult for the City Planner to get out and keep the Code Enforcement going.

Alderman Gustafson stated that he has been pushing for a Code Enforcement Officer for a while and that this position is needed. He stated that being reactive upsets a lot of residents and that he prefers to be proactive.

Alderman Kenny questioned how much money is generated from ticketing. Mr. Gombac reported that on a \$200 fine the City gets approximately \$30-\$50.

Mr. Gombac reported that he is recommending an individual who has 20-25 years in Code Enforcement and who is contracted with Willowbrook.

There was some discussion from the Committee on getting a resume and summary for discussion at the next meeting.

There was no one else in the audience wishing to present public comment.

Alderman Belczak made a motion, and it was seconded by Alderman Gustafson to table the Resolution approving the services for Code Enforcement Officer to the next meeting.

Upon voice vote, the MOTION CARRIED UNANIMOUSLY 3-0.

- h. Resolution – Approval to enter into an engineering agreement with Christopher B. Burke Engineering for professional services related to a Controlled Wetland Management Burn and Vegetation Management at the Dale Road Basin in an amount not to exceed \$27,750.00.**

Mr. Dan Gombac, Director reported that this is an engineering agreement with Christopher B. Burke Engineering for a controlled burn consisting of 4-acres and commonly referred to as the Dale Basin. He reported that as part of wetland management, fire has been treated as a management tool for wetlands with its major use for the eradication of undesirable vegetation and decaying plants. He reported that the scope of work to be performed by Christopher B. Burke Engineering includes permitting, notifications, controlled burns, vegetation management and reports.

There was no one else in the audience wishing to present public comment.

Alderman Gustafson made a motion, and it was seconded by Alderman Kenny approval of a Resolution to enter into an engineering agreement with Christopher B. Burke Engineering for professional services related to a Controlled Wetland Management Burn and Vegetation Management at the Dale Road Basin in an amount not to exceed \$27,750.00.

Upon voice vote, the MOTION CARRIED UNANIMOUSLY 3-0.

- i. Resolution – Approval to enter into an agreement for professional services related to Management and Monitoring of 10-acres of Wetland/Natural Areas within the Tara Hill subdivision for a five-year period in an amount not to exceed \$25,000.00.**

Mr. Dan Gombac, Director reported that this is an agreement renewal with Christopher B. Burke Engineering, Ltd. for the Monitoring of the Tara Hill Wetlands/Natural Areas. He reported that the wetlands are under the jurisdiction of the DuPage County Storm Water and Wetland

Ordinance and it is the City of Darien's responsibility to maintain the area through the established Special Service Area Agreement on file and to enforce any violations of the ordinance, such as destruction of the wetland area, dumping, or mowing in the buffer areas.

Mr. Gombac reported that the proposed contract is a multi-year contract as it allows the City and the consultant to maintain the wetlands to an optimal level and that the five-year program allows an opportunity to maintain costs with no increases through an efficient management plan.

There was no one else in the audience wishing to present public comment.

Alderman Belczak made a motion, and it was seconded by Alderman Gustafson approval of a Resolution to enter into an agreement for professional services related to Management and Monitoring of 10-acres of Wetland/Natural Areas within the Tara Hill subdivision for a five-year period in an amount not to exceed \$25,000.00.

Upon voice vote, the MOTION CARRIED UNANIMOUSLY 3-0.

- j. Resolution - Preliminary approval for the 2021 Street Maintenance contract with Brothers Asphalt Paving, Inc. as per the following schedule of pricing: base bid - \$1,218,851.55; alternate 1 - patching - \$ 89,100.00; alternate 2 – aggregate shoulders - \$24,000.00; alternate 3 - 67th Street realignment - \$96,818.75 for a total of \$1,428,770.30.**

Mr. Dan Gombac, Director reported that this year's 2021 Street Maintenance Program includes 4.64 miles to be resurfaced. He reported that the proposed program is the same program that was cancelled last year due to the COVID-19 Pandemic.

Mr. Gombac reported that typically the City averages approximately 5 miles of resurfacing per year.

There was no one else in the audience wishing to present public comment.

Alderman Kenny made a motion, and it was seconded by Alderman Gustafson preliminary approval for the 2021 Street Maintenance contract with Brothers Asphalt Paving, Inc. as per the following schedule of pricing: base bid - \$1,218,851.55; alternate 1 - patching - \$ 89,100.00; alternate 2 – aggregate shoulders - \$24,000.00; alternate 3 - 67th Street realignment - \$96,818.75 for a total of \$1,428,770.30.

Upon voice vote, the MOTION CARRIED UNANIMOUSLY 3-0.

K. Minutes – September 28, 2020 Municipal Services Committee

There was no one in the audience wishing to present public comment.

Chairperson Belczak noted the name change from Kara Smith to Karen Smith. Alderman Kenny noted words missing from his statement.

Alderman Kenny made a motion, and it was seconded by Alderman Gustafson approval of the September 28, 2020 Municipal Services Committee Meeting Minutes as amended.

Upon voice vote, the MOTION CARRIED UNANIMOUSLY 3-0.

DIRECTOR'S REPORT

There was no report.

NEXT SCHEDULED MEETING

Chairperson Belczak announced that the next meeting is scheduled for Monday, February 22, 2021.

ADJOURNMENT

With no further business before the Committee, Alderman Gustafson made a motion, and it was seconded by Alderman Kenny to adjourn. Upon voice vote, THE MOTION CARRIED unanimously, and the meeting adjourned at 8:15 p.m.

RESPECTFULLY SUBMITTED:

**Thomas Belczak
Chairman**

**Eric Gustafson
Alderman**

**Joseph Kenny
Alderman**