

\*\*\*\*\*  
**PRE-COUNCIL WORK SESSION — 7:00 P.M.**  
\*\*\*\*\*

Agenda of the Regular Meeting

of the City Council of the

**CITY OF DARIEN**

August 2, 2010

7:30 P.M.

1. Call to Order
2. Pledge of Allegiance
3. Roll Call
4. Declaration of Quorum
5. Approval of Minutes — [Committee-Of-The-Whole, July 19, 2010](#)  
— [City Council, July 19, 2010](#)
6. Receiving of Communications
7. Mayor's Report
8. City Clerk's Report
9. City Administrator's Report
10. Department Head Information/Questions
11. Treasurer's Report
  - A. Warrant Number — [10-11-06](#)
12. Standing Committee Reports
13. Questions and Comments — Agenda Related (This is an opportunity for the public to make comments or ask questions on any item on the Council's Agenda.)
14. Old Business
15. Consent Agenda
  - A. Consideration of a Motion to Grant a Waiver of the Raffle License Bond Requirement for the [Veterans of Foreign Wars of the U.S., Memorial Post 2838](#)
  - B. Consideration of a Motion to Approve an Ordinance Approving a Variation to the Darien Sign Code (PZC 2010-09: [8975 Lemont Road, Circle K/Shell](#))
  - C. Consideration of a Motion to Approve a Resolution to Accept a [Plat of Dedication for Ashbrook Court and Certain Property](#)
  - D. Consideration of a Motion to Approve [a Resolution Authorizing the Mayor to Accept a Proposal from Omni Pump Repairs](#) in an Amount not to Exceed \$15,800.00 to Re-Build Internal Critical Components of Three Pumps Located at Plant Two-1220 Plainfield Road
  - E. Consideration of a Motion to Approve [a Resolution Authorizing the Purchase of One New Asphalt Hotbox Trailer](#) from Bonnell Industries in the Amount of \$17,945.00
  - F. Consideration of a Motion to Approve [a Resolution Authorizing the Purchase of One New Nine Ton Dovetail Trailer](#) from A & W Truck and Trailer in the Amount of \$6,555.00
  - G. Consideration of a Motion to Approve [a Resolution Authorizing the City Administrator to Enter into an Agreement with Tri-State Fire Protection District](#) to Place Radio Antennas on the Tower Located at 1041 S. Frontage Road
16. New Business

17. Questions, Comments and Announcements — General (This is an opportunity for the public to make comments or ask questions on any issue.)
18. Adjournment

Agenda 8/02/10

**Minutes of the Committee of the Whole**

**of the**

**CITY OF DARIEN**

**JULY 19, 2010**

1. **CALL TO ORDER**

The Committee of the Whole meeting was called to order at 6:30 P.M. by Mayor Weaver.

2. Present: Halil Avci Sylvia McIvor  
John Galan John F. Poteraske, Jr.  
Carolyn A. Gattuso Ted V. Schauer  
Joseph A. Marchese

Absent: None

Also in Attendance: Kathleen Moesle Weaver, Mayor  
Joanne F. Coleman, City Clerk  
Michael J. Coren, City Treasurer  
Bryon D. Vana, City Administrator  
Daniel Gombac, Director of Community Development/Municipal Services  
David Skala, Deputy Chief

**DECLARATION OF A QUORUM** — There being seven aldermen present, Mayor Weaver declared a quorum.

3. **75<sup>TH</sup> STREET EXPANSION**

Mayor Weaver advised that the meeting was called in order to be certain all Council Members had a chance to see all of the revisions to the county's 75<sup>th</sup> Street Expansion Plan prior to approval of the resolution on this evening's agenda.

Mayor Weaver asked if there were any questions and/or comments. There were none.

Mayor Weaver remarked that the city should have requested overhead, illuminated signs at Cass and 75<sup>th</sup> as a part of the expansion plans.

Director Gombac advised that the lighted signs were requested. The county is conducting a study as to whether or not the signs will be made a part of the plan.

Alderman Marchese recalled, from the meeting, that the signs could be installed at the city's cost.

Director Gombac advised that the county's main concern is that the signs would not be visible at night if the power goes out.

Administrator Vana believes the city would bear the expense of the overhead, illuminated signs if the lighting selected was theme or above the standard.

Director Gombac agreed, and recalled the county will look into the overhead, illuminated signs.

Mayor Weaver questioned how an overhead, illuminated sign at Fairview and Maple was merited. Mayor Weaver would like to be assured that the city is not charged for something other municipalities received at no cost.

A discussion took place on various locations where the overhead, illuminated signs are posted in other municipalities.

Mayor Weaver would like to see overhead, illuminated signs at the major intersections in town.

Alderman Avci stated that he is comfortable with the county's proposal, and as long as the city is reserving the right for further input, he will support the resolution.

Alderman Schauer inquired about the right turn lane when heading southbound on 75<sup>th</sup> Street near Walmart. Alderman Schauer advised his concern is due to the fact that motorists are consistently using the shoulder at this location.

Director Gombac responded that he will double check the plans and report back.

Clerk Coleman expressed concern with how motorists will enter Brookhaven when traveling northbound on Cass.

Alderman Marchese stated that the county found it necessary to create an extended median in order to have a longer stacking lane. There is to be a sign posted which will allow motorists who are traveling southbound on Cass to make a U-turn at Plainfield Road to enter Heritage Center. Alderman Marchese added that once Heritage Center is redeveloped, the county will be open to new curb cuts on 75<sup>th</sup> Street and Plainfield Road just east of Cass.

Administrator Vana noted that the county verbally agreed to the curb cuts. Administrator Vana added that, as with any new development, the county would have to review the plans prior to any formal agreement.

Alderman Poteraske added that the curb cuts would need to be further away from the intersections.

Mayor Weaver agreed.

Administrator Vana commented that the expansion plans have been in process since 1991. The city passed resolutions opposing the plans in 1991, and again in 1995.

4. **ADJOURNMENT**

Mayor Weaver adjourned the meeting at 6:56 P.M.

---

Mayor

---

City Clerk

ld

A CITY COUNCIL COMMITTEE OF THE WHOLE MEETING WAS CALLED TO ORDER AT 6:45 P.M. BY MAYOR WEAVER. THE MEETING ADJOURNED AT 6.56 P.M.

A WORK SESSION WAS CALLED TO ORDER AT 7:00 P.M. BY MAYOR WEAVER FOR THE PURPOSE OF REVIEWING ITEMS ON THE JULY 19, 2010 AGENDA WITH THE CITY COUNCIL. THE SESSION ADJOURNED AT 7:21 P.M.

**Minutes of the Regular Meeting**

**of the City Council of the**

**CITY OF DARIEN**

**JULY 19, 2010**

1. **CALL TO ORDER**

The regular meeting of the City Council of the City of Darien was called to order at 7:30 P.M. by Mayor Weaver.

2. **PLEDGE OF ALLEGIANCE**

Mayor Weaver led the Council and audience in the Pledge of Allegiance.

3. **ROLL CALL** — The Roll Call of Aldermen by Clerk Coleman was as follows:

Present:	Halil Avci	Sylvia McIvor
	John Galan	John F. Poteraske, Jr.
	Carolyn A. Gattuso	Ted V. Schauer
	Joseph A. Marchese	

Absent: None

Also in Attendance: Kathleen Moesle Weaver, Mayor  
Joanne Coleman, City Clerk  
Michael J. Coren, City Treasurer  
Bryon D. Vana, City Administrator  
Daniel Gombac, Director of Community Development/Municipal Services  
David Skala, Deputy Chief

4. **DECLARATION OF A QUORUM** — There being seven aldermen present, Mayor Weaver declared a quorum.

5. **APPROVAL OF MINUTES** – June 21, 2010

It was moved by Alderman Gattuso and seconded by Alderman Galan to approve the minutes of the June 21, 2010 meeting, as presented.

Roll Call: Ayes: Avci, Galan, Gattuso, Marchese, McIvor, Poteraske, Schauer

Nays: None

Absent: None

Results: Ayes 7, Nays 0, Absent 0

**MOTION DULY CARRIED**

6. **RECEIVING OF COMMUNICATIONS**

Alderman Galan advised that following the Lions Club Independence Day Parade, several residents approached him at Picnic in the Park regarding concerns over vandalism and hooligans loitering at the park. Alderman Galan brought those concerns to Chief Pavelchik who advised that a plan has been instituted utilizing Office Skweres as a visible presence in the park. Officers have been put on notice to keep a vigilant eye on park activities. Alderman Galan expressed satisfaction with the plan the Police Department has put into action.

Mayor Weaver noted that the city has been very well aware of the situation, and has been in communication with the Park District to form a solution. Mayor Weaver expressed pleasure with the Police Department's proactive approach to this problem.

Alderman Galan encouraged residents who live near the park to feel free to contact the police regarding any questionable or uncomfortable situations. Alderman Galan suggested that residents might be interested in forming Neighborhood Watch programs. This can be accomplished by contacting the Police Department.

Deputy Chief Skala added that additional measures are being taken at the parks, such as leaving the lights on longer, and locking the restrooms. The Park District and Police communicate regularly.

Alderman Avci received correspondence from, and spoke with Vinay Soni, a U.S. Census worker who was seeking information on unoccupied houses in his Ward. Alderman Avci referred Mr. Soni to Assistant Administrator Coren.

Mayor Weaver advised that she has been similarly contacted by U. S. Census workers.

Alderman Avci provided a report on a meeting he and Assistant Administrator Coren had with PACE representatives on July 15. Following research, PACE representatives feel there is the potential for adding a Park and Ride bus stop in Darien for the route which runs from Plainfield to a downtown medical complex. Currently, the only stop is in Bolingbrook. Assistant Administrator Coren is looking into potential locations for the Park and Ride bus stop in Darien.

Mayor Weaver added that staff has identified two properties for this stop. Mayor Weaver would also like to see a bus stop at Myers Senior Housing.

7. **MAYOR'S REPORT**

Mayor Weaver extended her gratitude to Panera Bread for hosting Coffee with the Mayor this past Saturday.

**A. INDIAN PRAIRIE LIBRARY UPDATE**

Mayor Weaver introduced President of the Indian Prairie Library Board, Marian Krupicka, who provided a review of the highlights of the renovation project which will begin next week. It is anticipated the project will be completed in three to four months. The main floor, which will be designated for adults, will have a computer area and a café. The second floor will be dedicated to children ranging from preschool to teens. There will also be an additional adult rest room on the second floor. The library is financially sound, and will be approving their budget this Wednesday. Despite lack of funding from the state, the library will continue to provide delivery service between libraries and the on-line coordination system.

Alderman McIvor noted that when Farmingdale Village was annexed into Darien, residents chose, by referendum, not to join the library district. Alderman McIvor requested Ms. Krupicka describe the process for placing the referendum on the ballot again.

Ms. Krupicka advised that, in the current economy, that issue has been placed on hold. Ms. Krupicka noted that the library offers non-resident cards at a cost under \$200 for a family.

In response to Mayor Weaver, Ms. Krupicka advised that once the economy improves, if enough interest is expressed, the library would consider placing this referendum question on the ballot.

Alderman Marchese complimented the library on the services provided to children.

Mayor Weaver invited Ms. Krupicka to feel free to attend future Council Meetings with renovation updates.



Ms. Krupicka commented that the library will host an open house upon completion of the renovations, and the City Council Members will be invited.

**B. COLLEGE OF DUPAGE UPDATE**

Mayor Weaver introduced College of DuPage Relations Specialist, Jennifer Duda. As part of the CODiscover Listening Tour, Ms. Duda provided information on the College of DuPage, the many programs offered, and their plans for the future. COD has broken ground on two new facilities – Homeland Security Education Center and the Culinary Arts Building. COD has identified approximately \$168 million dollars in necessary upgrades and repairs of facilities. A referendum is being considered for a no tax rate increase which would allow a tax rate freeze over the next ten or fifteen years. Questions, comments and input are sought and welcome.

Mayor Weaver invited Ms. Duda to come back at any time with further updates.

8. **CITY CLERK'S REPORT**

There was no report.

9. **CITY ADMINISTRATOR'S REPORT**

There was no report.

10. **DEPARTMENT HEAD INFORMATION/QUESTIONS**

In response to Alderman Avci, Director Gombac advised that, due to an efficient schedule, the city is in good shape as far as construction projects are concerned. There are currently two ditching project restorations to complete. Until the union contract is settled, the city is unable to obtain the restoration materials.

In response to Alderman McIvor, Director Gombac advised there will be no impact on the budget based on the union contract.

Director Gombac advised that the Metropolitan Mayors Caucus Survey regarding the July storm damage and costs incurred has been completed and submitted. The Metropolitan Mayors Caucus will file the survey with the federal government for possible reimbursement of the \$51,000 expended.

11. **TREASURER'S REPORT**

**A. WARRANT NUMBER 10-11-05**

It was moved by Alderman Schauer and seconded by Alderman Gattuso to approve payment of Warrant Number 10-11-05 in the amount of \$100,979.23 from the General Fund; \$210,298.33 from the Water Fund; \$13,480.05 from the Motor Fuel Tax Fund; \$2,130.22 from the Darien Area Dispatch Fund; \$814,529.89 from the Capital Improvement Fund; \$7,000.00 from the Drug Forfeiture Fund; \$447,653.04 from the General Fund Payroll for the period ending 07/03/10 & 07/15/10; \$37,104.68 from the Water Fund Payroll for the period ending 07/03/10 & 07/15/10; \$58,525.28 from the D.A.D.C. Fund Payroll for the period ending 07/03/10 & 07/15/10 for a total to be approved of \$1,691,700.50.

Roll Call: Ayes: Avci, Galan, Gattuso, Marchese, McIvor, Poteraske, Schauer

Nays: None

Absent: None

Results: Ayes 7, Nays 0, Absent 0

**MOTION DULY CARRIED**

**B. TREASURER'S MONTHLY REPORT – JUNE, 2010**

Treasurer Coren reviewed all year-to-date sources of revenue and expenditures and fund balances through the month of June, 2010: General Fund Revenue \$2,629,070; General Fund Expenditures \$3,497,562; Current General Fund Balance \$2,088,275; Water Fund Revenue \$1,241,048; Water Fund Expenditures \$408,983; Current Water Fund Balance \$1,044,047; Motor Fuel Tax Fund Revenue \$100,785; Motor Fuel Tax Fund Expenditures \$50,746; Current Motor Fuel Tax Fund Balance \$1,317; Water Depreciation Fund Revenue \$1,013; Water Depreciation Fund Expenditures \$550,000; Current Water Depreciation Fund Balance \$188,628; Capital Improvement Fund Revenue \$1,686,107; Capital Improvement Fund Expenditures \$926,096; Current Capital Improvement Fund Balance \$1,422,004; Capital Projects Debt Service Fund Revenue \$55,440; Capital Projects Debt Service Fund Expenditures \$95,285; and a current fund balance of \$4,098.

12. **STANDING COMMITTEE REPORTS**

**Police Committee** — Alderman McIvor submitted the minutes of the Police Committee Meeting of June 10, 2010 for the record, and advised that the next Police Committee

meeting is scheduled to take place on Thursday, August 5, 2010 at 6:00 P.M. in the Council Chambers.

**Municipal Services Committee** — Alderman Marchese advised that the next Municipal Services Committee Meeting is scheduled to take place on Monday, July 26, 2010 at 6:30 P.M. in the Council Chambers.

**Administrative/Finance Committee** — Alderman Poteraske advised that the next Administrative and Finance Committee Meeting is scheduled to take place on Monday, August 9, 2010 at 6:30 P.M. in the upstairs conference room.

13. **QUESTIONS AND COMMENTS — AGENDA RELATED**

There were none.

14. **OLD BUSINESS**

There was no old business to come before the City Council.

15. **CONSENT AGENDA**

Mayor Weaver announced that during the Work Session, Item B under the Consent Agenda has been removed, and Items C, D, and E will become B, C, and D. Mayor Weaver added that New Business Items A, B, and C have been moved to the Consent Agenda as Items E, F, and G.

Mayor Weaver reviewed the Consent Agenda items for the benefit of the viewing audience.

It was moved by Alderman Marchese and seconded by Alderman McIvor to approve by Omnibus Vote the following items on the Consent Agenda:

- A. **ORDINANCE NO. O-18-10**                      **CONSIDERATION OF A MOTION TO APPROVE AN ORDINANCE AMENDING SECTION 3-3-7-5(C) OF THE DARIEN CITY CODE**
  
- B. **CONSIDERATION OF A MOTION TO APPROVE THE RECOMMENDATION OF RELEASING EXECUTIVE SESSION MINUTES THAT NO LONGER REQUIRE CONFIDENTIALITY**
  
- C. **RESOLUTION NO. R-48-10**                      **CONSIDERATION OF A MOTION TO APPROVE A RESOLUTION TO**

**INCLUDE COMPENSATION PAID UNDER AN INTERNAL REVENUE CODE SECTION 125 PLAN AS IMRF EARNINGS**

**D. RESOLUTION NO. R-49-10**

**CONSIDERATION OF A MOTION TO APPROVE A RESOLUTION APPROVING THE EMERGENCY OPERATIONS PLAN ASSEMBLED BY PUBLIC SAFETY PLANNING SOLUTIONS AND STAFF DURING FYE 2010**

**E. ORDINANCE NO. O-19-10**

**CONSIDERATION OF A MOTION TO APPROVE AN ORDINANCE AMENDING SECTION 9-2-2 (STOP SIGNS) OF CHAPTER 2 (TRAFFIC SIGNS AND SIGNAL LOCATIONS) TITLE 9 (TRAFFIC REGULATIONS) OF THE DARIEN CITY CODE**

**F. RESOLUTION NO. R-50-10**

**CONSIDERATION OF A MOTION TO APPROVE A RESOLUTION AUTHORIZING THE MAYOR TO ACCEPT A PROPOSAL FROM RAM MECHANICAL SERVICES, INC. TO REMOVE AND REPLACE THE COMPRESSORS FOR THE HVAC UNIT FOR THE POLICE DEPARTMENT FACILITY IN AN AMOUNT NOT TO EXCEED \$9,939.00**

**G. RESOLUTION NO. R-51-10**

**CONSIDERATION OF A MOTION TO APPROVE A RESOLUTION STATING THE POSITION OF THE MAYOR AND CITY COUNCIL OF THE CITY OF DARIEN IN RELATION TO THE COUNTY'S PRELIMINARY PLAN DATED JUNE 18, 2010 FOR IMPROVEMENTS TO 75<sup>TH</sup> STREET THROUGH THE CITY OF DARIEN**

**City Council Meeting**

**July 19, 2010**

Roll Call: Ayes: Avci, Galan, Gattuso, Marchese, McIvor, Poteraske, Schauer

Nays: None

Absent: None

Results: Ayes 7, Nays 0, Absent 0

**MOTION DULY CARRIED**

At the request of Administrator Vana, Mayor Weaver provided a more complete overview of Item G for the benefit of the viewing audience. Mayor Weaver advised that residents are welcome to view the county's plan for the expansion of 75<sup>th</sup> Street which is on display in the lobby of City Hall. In addition, staff would be happy to meet with residents to review the changes which were made to the original plan. DuPage County will apprise the City Council of major changes to the plan.

Administrator Vana noted that the city fought against the county's original plan, and the revised plan is much improved.

Alderman McIvor mentioned that an ordinance Amending the Traffic Signs and Signal Locations of the Darien City Code was approved this evening. The majority of stop sign locations are along Beller Road in Farmingdale Village. The traffic study noted that Beller Road is a collector street, and therefore, all intersecting streets are to have stop signs. Alderman McIvor wanted the residents of Farmingdale Village to be aware of why the signs are being installed. Mayor Weaver added that two stop signs will be removed – one at 79<sup>th</sup> and Farmingdale Drive, and the other at Walnut and Warwick.

16. **NEW BUSINESS**

Items A, B, and C under New Business were moved to the Consent Agenda.

17. **QUESTIONS, COMMENTS AND ANNOUNCEMENTS — GENERAL**

Arleta Peknik of 609 – 72<sup>nd</sup> Street thanked Director Gombac and his team for assistance in repairing the sink hole on a neighbor's driveway.

18. **ADJOURNMENT**

There being no further business to come before the City Council, it was moved by Alderman McIvor and seconded by Alderman Gattuso to adjourn.

**VIA VOICE VOTE – MOTION DULY CARRIED**

The City Council meeting adjourned at 8:16 P.M.

---

Mayor

---

City Clerk

ld

All supporting documentation and report originals of these minutes are on file in the Office of the City Clerk under File Number 07-19-10.  
Minutes of 07-19-10 CCM

CITY OF DARIEN

EXPENDITURE APPROVAL LIST  
FOR CITY COUNCIL MEETING ON  
August 2, 2010

Approval is hereby given to have the City Treasurer of Darien, Illinois pay to the officers, employees, independent contractors, vendors, and other providers of goods and services in the indicated amounts as set forth.

A summary indicating the source of funds used to pay the above is as follows:

General Fund		\$136,395.57
Water Fund		\$6,387.83
Motor Fuel Tax Fund		\$3,552.91
Water Depreciation Fund		
Darien Area Dispatch Fund		\$972.35
Capital Improvement Fund		\$4,473.34
Debt Service Fund		
Special Service Area Tax Fund		
Drug Forfeiture Fund		
	<i>Subtotal:</i>	<u>\$ 151,782.00</u>
General Fund Payroll	7/29/2010	\$ 211,400.30
Water Fund Payroll	7/29/2010	\$ 22,550.84
D.A.D.C. Payoll	7/29/2010	\$ 29,751.15
	<i>Subtotal:</i>	<u>\$ 263,702.29</u>

*Total to be Approved by City Council:* \$ 415,484.29

*Approvals:*

\_\_\_\_\_  
Kathleen Moesle Weaver, Mayor

\_\_\_\_\_  
Joanne F. Coleman, City Clerk

\_\_\_\_\_  
Michael J. Coren, Treasurer

\_\_\_\_\_  
Bryon D. Vana, City Administrator

**CITY OF DARIEN**  
**Expenditure Journal**  
**General Fund**  
**Administration**  
**From 7/20/2010 Through 8/2/2010**

<u>Vendor Name</u>	<u>Invoice Description</u>	<u>Acct Title</u>	<u>Dept Amount</u>	<u>Acct Code</u>
AIS	WIRELESS RADIO FOR PW	Consulting/Professional	1,179.00	4325
AIS	FUSER IT	Consulting/Professional	237.96	4325
AIS	LIVESCAN BATTERY BACKUP & DARIENIL.GOV INITIAL REGISTRATION	Consulting/Professional	125.00	4325
AIS	LIVESCAN BATTERY BACKUP	Consulting/Professional	65.00	4325
AIS	JUNE, 2010 COMPUTER SUPPORT	Consulting/Professional	5,950.00	4325
CALL ONE, INC.	TELEPHONES & DATA LINES	Telephone	2,536.42	4267
CHICAGO METROPOLITAN FIRE PREV	FIRE ALARM MONITORING JULY 1, 2010 THRU SEPTEMBER 30, 2010	Telephone	252.00	4267
DUPAGE COUNTY PUBLIC WORKS	1702 PLAINFIELD ROAD - APRIL 27-JUNE 25, 2010	Utilities (Elec,Gas,Wtr,Sewer)	24.16	4271
HR SIMPLIFIED	COBRA NOTIFICATIONS	Liability Insurance	50.00	4219
IL DIRECTOR OF EMPLOY SECURITY	UNEMPLOYMENT BENEFITS - SECOND QUARTER ENDING 06-30-10	Salaries	2,695.00	4010
ILLINI POWER PRODUCTS	GENERATOR REPAIRS	Maintenance - Equipment	875.49	4225
KING CAR WASH	CAR WASH	Maintenance - Vehicles	7.50	4229
MUNICIPAL CLERKS OF DUPAGE CO.	ANNUAL MEMBERSHIP DUES - JOANNE COLEMAN & LYNN DUBMAN	Dues and Subscriptions	35.00	4213
MUNICIPAL WEB SERVICES	JUNE, 2010 WEBSITE MAINTENANCE	Consulting/Professional	693.75	4325
NEXTEL COMMUNICATIONS	CELLULAR SERVICE - JUNE 7 - JULY 6, 2010	Telephone	1,852.40	4267



**CITY OF DARIEN**  
**Expenditure Journal**  
**General Fund**  
**Administration**  
**From 7/20/2010 Through 8/2/2010**

<u>Vendor Name</u>	<u>Invoice Description</u>	<u>Acct Title</u>	<u>Dept Amount</u>	<u>Acct Code</u>
OFFICE DEPOT	SUPPLIES	Supplies - Office	18.33	4253
OFFICEMAX CONTRACT INC.	SUPPLIES	Supplies - Office	27.60	4253
OFFICEMAX CONTRACT INC.	SUPPLIES	Supplies - Office	35.96	4253
SIKICH PROFESSIONAL SERVICES	AUDIT OF FYE10 BOOKS	Audit	12,275.00	4320
VELOCITA TECHNOLOGY	COMPATIBLE TONER CARTRIDGE	Supplies - Office	41.92	4253
VELOCITA TECHNOLOGY	COMPATIBLE TONER CARTRIDGE	Supplies - Office	119.47	4253
Total Administration			29,096.96	

**CITY OF DARIEN**  
**Expenditure Journal**  
**General Fund**  
**City Council**  
**From 7/20/2010 Through 8/2/2010**

<u>Vendor Name</u>	<u>Invoice Description</u>	<u>Acct Title</u>	<u>Dept Amount</u>	<u>Acct Code</u>
ILLINOIS STATE POLICE	FINGERPRINTING FEE - JENNIFER TIBBITS - CHUCK E. CHEESE	Boards and Commissions	39.25	4205
		Total City Council	39.25	

**CITY OF DARIEN**  
**Expenditure Journal**  
**General Fund**  
**Public Works, Streets**  
**From 7/20/2010 Through 8/2/2010**

Vendor Name	Invoice Description	Acct Title	Dept Amount	Acct Code
CHEMSEARCH	P-O-W PLUS AEROSOL	Supplies - Other	157.44	4257
CHRISTOPHER B. BURKE ENG, LTD	DESIGN SERVICES - 2010 STREET PROGRAM	Consulting/Professional	1,012.00	4325
CINTAS FIRST AID AND SAFETY	FIRST AID	Liability Insurance	98.43	4219
CINTAS FIRST AID AND SAFETY	EAR PLUGS	Liability Insurance	37.89	4219
CITIZENS FINANCIAL BANK	VEHICLE LOAN PAYMENT 4 OF 5 - LOAN #5171249	Equipment	87,119.25	4815
COM ED	STREET LIGHTS - ACCT 2343005070	Street Light Oper & Maint.	8.49	4359
COM ED	STREET LIGHTS	Street Light Oper & Maint.	1,275.44	4359
CULLIGAN	WATER & FILTER RENTAL	Maintenance - Building	157.38	4223
EMBASSY REFRESHMENT SERVICE	COFFEE, SUGAR & CREAM	Maintenance - Building	47.61	4223
FIRE & SECURITY SYSTEMS, INC.	FIRE ALARM AT PUBLIC WORKS	Maintenance - Building	75.00	4223
GAFFNEY'S PROTECTIVE MAINTENAN	STREET LIGHT REPAIR - SIX LOCATIONS	Street Light Oper & Maint.	384.00	4359
GAFFNEY'S PROTECTIVE MAINTENAN	STREET LIGHT REPAIR AT 2 LOCATIONS	Street Light Oper & Maint.	128.00	4359
GAFFNEY'S PROTECTIVE MAINTENAN	STREET LIGHT REPAIR AT 4 LOCATIONS	Street Light Oper & Maint.	256.00	4359
GENE'S TIRE SERVICE, INC.	TIRES FOR MOWER	Maintenance - Equipment	48.78	4225
LAWSON PRODUCTS INCORPORATED	SUPPLIES	Supplies - Other	215.94	4257
NICOR GAS	1041 S. FRONTAGE RD., ACCT NO. 90-84-11-1000 1	Utilities (Elec,Gas,Wtr,Sewer)	31.59	4271
O'HARA TRUE VALUE	SUPPLIES	Liability Insurance	6.49	4219
O'HARA TRUE VALUE	SUPPLIES	Maintenance - Building	32.01	4223
O'HARA TRUE VALUE	SUPPLIES	Supplies - Other	334.77	4257
PATTEN INDUSTRIES, INC.	LATCH	Maintenance - Equipment	77.08	4225
RED WING SHOES	BOOTS	Liability Insurance	191.00	4219
RED WING SHOES	UNIFORMS	Uniforms	354.98	4269
RENDEL'S, INC.	REPAIR PARTS	Maintenance - Vehicles	1,217.47	4229

**CITY OF DARIEN**  
**Expenditure Journal**  
**General Fund**  
**Public Works, Streets**  
**From 7/20/2010 Through 8/2/2010**

<u>Vendor Name</u>	<u>Invoice Description</u>	<u>Acct Title</u>	<u>Dept Amount</u>	<u>Acct Code</u>
RENDEL'S, INC.	REPAIR PARTS	Maintenance - Vehicles	166.60	4229
RENDEL'S, INC.	REPAIR PARTS	Maintenance - Vehicles	96.96	4229
TRAFFIC CONTROL AND PROTECTION	NO PARKING ON SCHOOL DAYS SIGNS	Supplies - Other	212.10	4257
TRAFFIC CONTROL AND PROTECTION	SIGNS	Supplies - Other	555.52	4257
WHOLESALE DIRECT, INC.	DURA BLADES	Maintenance - Vehicles	<u>242.14</u>	4229
		Total Public Works, Streets	94,540.36	

**CITY OF DARIEN**  
**Expenditure Journal**  
**General Fund**  
**Police Department**  
**From 7/20/2010 Through 8/2/2010**

<u>Vendor Name</u>	<u>Invoice Description</u>	<u>Acct Title</u>	<u>Dept Amount</u>	<u>Acct Code</u>
AIR-RITE HEATING & COOLING	HVAC REPAIR - WATER DRIPPING THROUGH CEILING	Maintenance - Equipment	186.00	4225
AMERICAN COP	TWO YEAR SUBSCRIPTION AMERICAN COP - JOHN COOPER	Dues and Subscriptions	29.50	4213
AWARD EMBLEM COMPANY	CIVILIAN PLATE ENGRAVING	Uniforms	4.14	4269
AWP CUSTOM UNIFORMS	TEE SHIRTS - JUNIOR POLICE ACADEMY	Public Relations	16.00	4239
AWP CUSTOM UNIFORMS	JUNIOR ACADEMY TEE SHIRTS	Public Relations	217.00	4239
DUPAGE COUNTY ANIMAL CONTROL	BOARD LHASA APSO FOR ONE DAY	Animal Control	60.00	4201
DUPAGE COUNTY PUBLIC WORKS	1710 PLAINFIELD ROAD SEWER & WATER	Utilities (Elec,Gas,Wtr,Sewer)	96.64	4271
DUPAGE COUNTY PUBLIC WORKS	1710 PLAINFIELD ROAD WATER & SEWER	Utilities (Elec,Gas,Wtr,Sewer)	36.24	4271
EV TECHNOLOGIES	SQUAD 25 REPAIR - LIGHT FAILURE	Maintenance - Vehicles	308.50	4229
FLEET SAFETY SUPPLY	SQUAD CAR LIGHT BRACKET	Maintenance - Vehicles	72.68	4229
GEOFF T. KOSIENIAK	TUITION REIMBURSEMENT 50%	Training and Education	39.00	4263
GLOBAL PROCUREMENT SERVICES	CROSSING GUARD STOP PADDLE REPAIR	Uniforms	25.03	4269
GLOCK, INC.	ARMORER'S COURSE 8-24-10 - J. COOPER & J. TOPEL	Training and Education	300.00	4263
GRAINGER	AIR FILTERS	Maintenance - Building	143.82	4223
IL DIRECTOR OF EMPLOY SECURITY	UNEMPLOYMENT BENEFITS - SECOND QUARTER ENDING 06-30-10	Salaries	4,268.00	4010

**CITY OF DARIEN**  
**Expenditure Journal**  
**General Fund**  
**Police Department**  
**From 7/20/2010 Through 8/2/2010**

<u>Vendor Name</u>	<u>Invoice Description</u>	<u>Acct Title</u>	<u>Dept Amount</u>	<u>Acct Code</u>
IL SECRETARY OF STATE POLICE	RENEWAL PLATES 2003 FORD TAURUS 1FAFP56S03A256154	Maintenance - Vehicles	99.00	4229
ILLINI POWER PRODUCTS	GENERATOR REPAIRS	Maintenance - Equipment	1,029.07	4225
ILLINOIS SECRETARY OF STATE	NOTARY PUBLIC COMMISSION - KIM WRIGHT	Dues and Subscriptions	10.00	4213
ILLINOIS SECRETARY OF STATE	NOTARY COMMISSION - JENNIFER L. CORLAS	Dues and Subscriptions	10.00	4213
JOHN JUMP	UNIFORM ALLOWANCE	Uniforms	145.69	4269
KAESER BLAIR INCORPORATED	PENS	Public Relations	389.65	4239
KALE UNIFORMS	UNIFORM ALLOWANCE - RUMICK	Uniforms	69.94	4269
KARA FOYLE-PRICE	UNIFORM ALLOWANCE	Uniforms	75.02	4269
KING CAR WASH	CAR WASH	Maintenance - Vehicles	278.00	4229
MASTER-BREW	COFFEE & COFFEE SUPPLIES	Travel/Meetings	73.90	4265
N.T.O.A.	ANNUAL MEMBERSHIP DUES - J. TOPEL	Dues and Subscriptions	40.00	4213
NICHOLAS SKWERES	REIMBURSEMENT - FOOD FOR JUNIOR POLICE ACADEMY	Public Relations	138.52	4239
NICHOLAS SKWERES	UNIFORM ALLOWANCE	Uniforms	209.74	4269
NICOR GAS	1710 PLAINFIELD RD - ACCT 82-80-00-1000 9	Utilities (Elec,Gas,Wtr,Sewer)	115.85	4271
NOTARIES ASSOCIATION OF IL	SELF-INKING NOTARY RUBBER STAMP SEAL	Dues and Subscriptions	14.00	4213
NOTARIES ASSOCIATION OF IL	NOTARY BOND	Dues and Subscriptions	16.00	4213
NOTARIES ASSOCIATION OF IL	MEMBERSHIP FEE	Dues and Subscriptions	8.00	4213
NOTARIES ASSOCIATION OF IL	MEMBERSHIP FEE	Dues and Subscriptions	8.00	4213
NOTARIES ASSOCIATION OF IL	NOTARY BOND	Liability Insurance	16.00	4219
NOTARIES ASSOCIATION OF IL	NOTARY STAMP	Supplies - Office	14.00	4253
OCE' IMAGISTICS INC.	COPIER MAINTENANCE APRIL 1 - JUNE 30, 2010	Maintenance - Equipment	131.40	4225

CITY OF DARIEN  
Expenditure Journal  
General Fund  
Police Department  
From 7/20/2010 Through 8/2/2010

Vendor Name	Invoice Description	Acct Title	Dept Amount	Acct Code
RAY O'HERRON CO. INC OF OBT	UNIFORM ALLOWANCE - SKWERES	Uniforms	200.75	4269
RAY O'HERRON CO. INC OF OBT	UNIFORM ALLOWANCE - SIMEK	Uniforms	13.95	4269
RAY O'HERRON CO. INC OF OBT	UNIFORM ALLOWANCE - ZIMNY	Uniforms	16.95	4269
RAY O'HERRON CO. INC OF OBT	UNIFORM ALLOWANCE - SKALA	Uniforms	11.95	4269
RAY O'HERRON CO. INC OF OBT	UNIFORM ALLOWANCE - YEO	Uniforms	25.95	4269
RAY O'HERRON CO. INC OF OBT	UNIFORM ALLOWANCE - RENNER	Uniforms	41.80	4269
RAY O'HERRON CO. INC OF OBT	UNIFORM ALLOWANCE - LOREK	Uniforms	16.95	4269
RAY O'HERRON CO. INC OF OBT	UNIFORM ALLOWANCE - MURPHY	Uniforms	189.95	4269
RAY O'HERRON CO. INC OF OBT	UNIFORM ALLOWANCE - MURPHY	Uniforms	299.95	4269
RAY O'HERRON CO. INC OF OBT	UNIFORM ALLOWANCE - MURPHY	Uniforms	88.85	4269
RAY O'HERRON CO. INC.	SPOT LIGHT ASSEMBLY FOR SQUADS	Maintenance - Vehicles	156.86	4229
RICOH AMERICAS CORPORATION	RICOH COPIER	Maintenance - Equipment	543.40	4225
SAM'S CLUB	SUPPLIES	Public Relations	19.87	4239
SAM'S CLUB	SUPPLIES	Public Relations	57.50	4239
STATE FIRE MARSHALL	ANNUAL BOILER INSPECTION	Maintenance - Equipment	100.00	4225
STEVEN LISS	REIMBURSEMENT - BOARDING QUANTO	Investigation and Equipment	137.50	4217
SUBURBAN DOOR CHECK & LOCK SVC	ELECTRIC DOOR LOCKS	Maintenance - Building	776.40	4223
SUBURBAN DOOR CHECK & LOCK SVC	ELECTRIC SOLENOID DOOR LOCKS	Maintenance - Building	228.00	4223
TEE'S PLUS	DARE SUPPLIES	Public Relations	356.28	4239
UNIQUE PRODUCTS & SERVICE CORP	JANITORIAL SUPPLIES	Maintenance - Building	31.50	4223
UNIQUE PRODUCTS & SERVICE CORP	JANITORIAL SUPPLIES	Maintenance - Building	112.11	4223

**CITY OF DARIEN**  
**Expenditure Journal**  
**General Fund**  
**Police Department**  
**From 7/20/2010 Through 8/2/2010**

<u>Vendor Name</u>	<u>Invoice Description</u>	<u>Acct Title</u>	<u>Dept Amount</u>	<u>Acct Code</u>
UNIQUE PRODUCTS & SERVICE CORP	JANITORIAL SUPPLIES	Maintenance - Building	103.72	4223
		Total Police Department	12,224.52	



**CITY OF DARIEN**  
**Expenditure Journal**  
**General Fund**  
**Business District**  
**From 7/20/2010 Through 8/2/2010**

<u>Vendor Name</u>	<u>Invoice Description</u>	<u>Acct Title</u>	<u>Dept Amount</u>	<u>Acct Code</u>
ALLIED WASTE SERVICES #551	REFUSE SERVICE 08/01/10 - 08/31/10 - 7515 S. CASS, UNIT D	Maintenance - Equipment	89.12	4225
DUPAGE COUNTY PUBLIC WORKS	7515 S. CASS, UNITS J & K - APRIL 26 - JUNE 24, 2010	Utilities (Elec,Gas,Wtr,Sewer)	11.04	4271
DUPAGE COUNTY PUBLIC WORKS	7515 S. CASS, UNIT C - APRIL 26-JUNE 24, 2010	Utilities (Elec,Gas,Wtr,Sewer)	11.04	4271
DUPAGE COUNTY PUBLIC WORKS	7515 S. CASS, UNIT D - APRIL 26-JUNE 24, 2010	Utilities (Elec,Gas,Wtr,Sewer)	383.28	4271
Total Business District			494.48	
Total General Fund			136,395.57	

**CITY OF DARIEN**  
**Expenditure Journal**  
**Water Fund**  
**Public Works, Water**  
**From 7/20/2010 Through 8/2/2010**

<u>Vendor Name</u>	<u>Invoice Description</u>	<u>Acct Title</u>	<u>Dept Amount</u>	<u>Acct Code</u>
ALEXANDER CHEMICAL CORPORATION	CHLORINE - USING \$900 CREDIT MEMO 0437024	Supplies - Operation	1,440.00	4255
CALL ONE, INC.	TELEPHONES & DATA LINES	Telephone	362.35	4267
CINTAS FIRST AID AND SAFETY	EAR PLUGS	Liability Insurance	37.90	4219
CINTAS FIRST AID AND SAFETY	FIRST AID	Liability Insurance	98.43	4219
COM ED	PLAINFIELD & MANNING - ACCT. 0437036069	Utilities (Elec,Gas,Wtr,Sewer)	25.51	4271
CULLIGAN	WATER & FILTER RENTAL	Maintenance - Building	157.38	4223
EMBASSY REFRESHMENT SERVICE	COFFEE, SUGAR & CREAM	Maintenance - Building	47.62	4223
HACH COMPANY	CHLORINE REAGENT SETS	Quality Control	193.51	4241
HAGEMEYER	RUBBER BOOTS	Liability Insurance	88.05	4219
HD SUPPLY WATERWORKS	VALVE KEY	Maintenance - Water System	136.03	4231
HD SUPPLY WATERWORKS	BLUE PRINT	Maintenance - Water System	448.80	4231
IL DIRECTOR OF EMPLOY SECURITY	UNEMPLOYMENT BENEFITS - SECOND QUARTER ENDING 06-30-10	Salaries	1,509.00	4010
NEXTEL COMMUNICATIONS	CELLULAR SERVICE - JUNE 7 - JULY 6, 2010	Telephone	347.33	4267
NICOR GAS	1930 MANNING RD, DOWNERS GROVE - ACCT 05-00-21-1000 4	Utilities (Elec,Gas,Wtr,Sewer)	31.91	4271
NICOR GAS	1041 S. FRONTAGE RD., ACCT NO. 90-84-11-1000 1	Utilities (Elec,Gas,Wtr,Sewer)	31.60	4271
NICOR GAS	8600 LEMONT ROAD - ACCT. 23-64-41-1000 1	Utilities (Elec,Gas,Wtr,Sewer)	45.42	4271
NICOR GAS	1897 MANNING DRIVE- ACCT 12 34 41 1000 7	Utilities (Elec,Gas,Wtr,Sewer)	30.42	4271
O'HARA TRUE VALUE	SUPPLIES	Maintenance - Building	61.49	4223

**CITY OF DARIEN**  
**Expenditure Journal**  
**Water Fund**  
**Public Works, Water**  
**From 7/20/2010 Through 8/2/2010**

<u>Vendor Name</u>	<u>Invoice Description</u>	<u>Acct Title</u>	<u>Dept Amount</u>	<u>Acct Code</u>
O'HARA TRUE VALUE	SUPPLIES	Maintenance - Water System	225.08	4231
SPRING-GREEN	FERTILIZER & WEED CONTROL AT PW	Maintenance - Building	1,070.00	4223
		Total Public Works, Water	6,387.83	
		Total Water Fund	6,387.83	

**CITY OF DARIEN**  
**Expenditure Journal**  
**Motor Fuel Tax**  
**MFT Expenses**  
**From 7/20/2010 Through 8/2/2010**

<u>Vendor Name</u>	<u>Invoice Description</u>	<u>Acct Title</u>	<u>Dept Amount</u>	<u>Acct Code</u>
KIEFT BROS., INC.	CURB FRAME & PARTS FOR FARMINGDALE	Supplies - Other	248.30	4257
KIEFT BROS., INC.	GRATE FOR 7825 REGENCY GROVE	Supplies - Other	125.00	4257
SALCE, INC.	CA6 AND CA7 STONE	Road Material	<u>3,179.61</u>	4245
		Total MFT Expenses	<u>3,552.91</u>	
		Total Motor Fuel Tax	3,552.91	

**CITY OF DARIEN  
Expenditure Journal  
Darrien Area Dispatch Center  
Darrien Area Dispatch  
From 7/20/2010 Through 8/2/2010**

<u>Vendor Name</u>	<u>Invoice Description</u>	<u>Acct Title</u>	<u>Dept Amount</u>	<u>Acct Code</u>
CALL ONE, INC.	TELEPHONES & DATA LINES	Telephone	724.70	4267
DUPAGE COUNTY TREASURER	JUNE 2010 CHARGES FOR DATA PROCESSING - LISLE	Data Processing	26.27	4336
DUPAGE COUNTY TREASURER	JUNE 2010 CHARGES DATA PROCESSING - DARIEN	Data Processing	42.35	4336
ILLINOIS APCO	QUALITY ASSURANCE CLASS SEPT 16, 2010 - DIANE DALY	Training and Education	25.00	4263
NEXTEL COMMUNICATIONS	CELLULAR SERVICE - JUNE 7 - JULY 6, 2010	Telephone	115.78	4267
PETTY CASH	PETTY CASH REIMBURSEMENT	Supplies - Office	1.99	4253
PETTY CASH	PETTY CASH REIMBURSEMENT	Supplies - Office	4.99	4253
PETTY CASH	PETTY CASH REIMBURSEMENT	Supplies - Office	7.98	4253
PETTY CASH	PETTY CASH REIMBURSEMENT	Travel/Meetings	6.00	4265
SAM'S CLUB	SUPPLIES	Supplies - Office	<u>17.29</u>	4253
		Total Darrien Area Dispatch	972.35	
		Total Darrien Area Dispatch Center	<u>972.35</u>	

**CITY OF DARIEN**  
**Expenditure Journal**  
**Capital Improvement Fund**  
**Capital Fund Expenditures**  
**From 7/20/2010 Through 8/2/2010**

<u>Vendor Name</u>	<u>Invoice Description</u>	<u>Acct Title</u>	<u>Dept Amount</u>	<u>Acct Code</u>
INTERSTATE CURB & CONCRETE CUT	SLAB SAWING FOR 8822 CARLISLE PROJECT	Ditch Projects	957.00	4376
KIEFT BROS., INC.	24-INCH INLET & GRATE FOR WINTERBERRY PROJECT	Ditch Projects	267.00	4376
KIEFT BROS., INC.	FRAME & GRATE FOR PROJECT 1529 WINTERBERRY	Ditch Projects	375.00	4376
LAND AND LAKES	DUMP FEES FOR PROJECT B-10 RICHMOND & C10 WESTERN	Ditch Projects	300.00	4376
NORWALK SALES CO.	12-IN HDPE FOR 8822 CARLISE & WINTERBERRY & FARMINGDALE	Ditch Projects	2,574.34	4376
		Total Capital Fund Expenditures	4,473.34	
		Total Capital Improvement Fund	4,473.34	
Report Total			151,782.00	

**AGENDA MEMO**  
**CITY COUNCIL**  
**Meeting Date: August 2, 2010**

**Issue Statement**

Consideration of a motion to grant waiver of the raffle license bond requirement for Veterans of Foreign Wars of the U.S., Darien Memorial Post 2838.

**BACKUP**

**Background/History**

VFW Darien Memorial Post 2838 has applied for a raffle license and requested a waiver of the bond requirements. The raffle is scheduled for Sunday, September 12, 2010 at the DarienFest celebration. The City regularly waives the bond requirement for qualified organizations.

**Staff/Committee Recommendation**

It is recommended that the raffle license bond requirement for VFW Darien Memorial Post 2838 be waived.

**Alternate Consideration**

Not granting waiver.

**Decision Mode**

This item will be placed on the August 2, 2010 Council Agenda for formal consideration.

# VFW

Veterans of Foreign Wars of the U.S.  
Darien Memorial Post 2838  
P.O. Box 955  
Westmont, Illinois, 60559

July 14, 2010

Joanne Coleman, City Clerk  
City of Darien  
1702 Plainfield Road  
Darien, IL 60561  
Dear Joanne,

Please accept this letter as a formal request to the City Council to waive the required bond for this year's raffle which will end with a drawing at DarienFest on Sunday afternoon. We will be conducting a 50/50 raffle wherein half of the amount of our sales (minus printing costs) is paid as a prize. The raffle is to fund our general operating budget line which includes donations and/or contributions to other community organizations and projects. An application for a raffle permit is attached.

The Veterans of Foreign Wars of the United States is a not-for-profit "veterans" organization as defined in your ordinances. If I can or need to furnish any additional information, please have your office contact me at (630) 654-1824. Thank you very much for this consideration.

God Bless America,

  
Edward Oldis  
Post Commander

VETERANS OF FOREIGN WARS OF THE UNITED STATES



CITY OF DARIEN

APPLICATION FOR RAFFLE LICENSE

NAME OF ORGANIZATION: Darien Veterans of Foreign Wars

ADDRESS: P.O. Box 955, Westmont, IL 60559

TELEPHONE NUMBER: (630) 654-1824 FAX NUMBER: \_\_\_\_\_

TYPE OF ORGANIZATION: Veterans  
(Charitable, Educational, Religious, Fraternal, Veterans or Labor)

LIST THE AREA(S) WITHIN THE CITY IN WHICH RAFFLE CHANCES WILL BE SOLD OR ISSUED:  
Community Park during DarienFest and possibly through personal contact; however they  
will not be sold door-to-door.

LIST THE TIME(S) OF DAY DURING WHICH RAFFLE CHANCES WILL BE SOLD OR ISSUED:  
During DarienFest hours

LIST THE DATE AND TIME OF THE DETERMINATION OF WINNING CHANCES:  
Sunday, September 12<sup>th</sup> 2010 at approximately 5:30 PM

LIST THE LOCATION(S) AT WHICH WINNING CHANCES WILL BE DETERMINED:  
DarienFest Mainstage

I, Edward Oldis, being the first duly sworn, state on oath that the foregoing organization is a not-for-profit organization.

Edward H. Oldis  
Presiding Officer

ATTEST:  
\_\_\_\_\_  
Secretary

APPROVED BY: \_\_\_\_\_ DATE: \_\_\_\_\_

MAILED ON: \_\_\_\_\_ BY: \_\_\_\_\_

**AGENDA MEMO**  
**CITY COUNCIL**  
**MEETING DATE: August 2, 2010**

**Issue Statement**

**PZC 2010-09:**                                **8975 Lemont Road, Circle K/Shell service station:** Petitioner seeks approval of a variation from the Sign Code to permit a LED price display.

**ORDINANCE**

**Discussion/Overview**

**Both the Planning and Zoning Commission and the Municipal Services Committee considered this matter at their regular meetings. Both bodies recommend approval of the petition, as presented, subject to the following:**

- 1.        LED price display is not to blink, flash, flutter, produce varying light intensity or have any other animated graphics.**

A draft ordinance is attached.

The complete agenda memo follows as “Additional Information.”

**Decision Mode**

The Planning/Zoning Commission considered this item at its meeting on July 7, 2010.  
The Municipal Services Committee considered this item at its meeting on July 26, 2010.  
The City Council will consider this matter at its meeting on August 2, 2010.

## Additional Information

### Issue Statement

**PZC 2010-09:**                                **8975 Lemont Road, Circle K/Shell service station:** Petitioner seeks approval of a variation from the Sign Code to permit a LED price display.

Applicable Regulations:            Sign Code, Section 4-3-7(C): Illumination of Signs

### General Information

Petitioner:                                Auna Foote  
Corporate ID Solutions  
5308 N. Northwest Highway  
Chicago, IL 60630

Property Owner:                        Circle K/Shell  
4080 Jonathan Moore Pike  
Columbus, IN 47201

Property Location:                    8975 Lemont Road

PIN:                                        10-05-105-027

Existing Zoning:                        B-3 General Business District

Existing Land Use:                    Service station with car wash and convenience store

#### Surrounding Zoning and Land Use:

North:        R-1 Single-Family Residence – open space.  
South:        B-3 General Business – farm field.  
East:         R-1 Single-Family Residence – open space.  
West:        R-2 Single-Family Residence (DuPage County) – single-family detached homes.

Comprehensive Plan Update: Commercial

Floodplain:                                None.

Natural Features:                        None.

Transportation:                        Property has frontage and access on Lemont Road and Cheese Road (N. Frontage Road).

## **Documents Submitted**

This report is based on the following information submitted to the Community Development Department by the petitioner:

1. [Sign drawing](#), 1 sheet, prepared by Corporate ID Solutions, dated March 22, 2010.
2. [LED sign panel](#), 1 sheet, prepared by Sign Resource, dated December 15, 2006.
3. [Plat of Survey](#), 1 sheet, prepared by Marchese and Sons, Inc., dated August 8, 1994.
4. [Summary of Variation Request](#), 2 sheets, prepared by Corporate ID Solutions, not dated.

## **Planning Overview/ Discussion**

The subject property is located on the east side of Lemont Road, at Cheese Road (N. Frontage Road), north of the Lemont Road/I-55 interchange.

The petitioner seeks to install a LED illuminated price display on an existing sign. The sign dimensions (area and height) will not change.

The Sign Code does not specifically permit LED sign displays. Therefore, staff has viewed such requests as requiring a variation. A variation from the Sign Code does not require a public hearing, public notice was not provided.

The petitioner submitted a letter indicating the price display will not blink or flicker. The LED display will show the gas price only, changed once per day at 2:00 AM.

The current Sign Code requires the sign base to be flush with the grade, that is, sign poles are prohibited. If the variation is approved, staff recommends installing a sign base to the sign.

The area surrounding the sign is landscaped, fulfilling the landscape requirements under the Sign Code.

The LED illumination details were sent to the City's consulting engineering firm for review. Staff hopes to have comments at the meeting. Regardless, the LED illumination brightness will be required to comply with the Sign Code.

In considering a sign variation, the following criteria shall be considered per the Sign Code:

1. The available locations for adequate signage on the property.
2. The effect of the proposed sign on pedestrian and motor traffic.
3. The cost to the applicant in complying with the Sign Code as opposed to the detriment, if any, to the public from granting of the variation.
4. If undue hardships and practical difficulties result in complying with the sign Code and if these hardships are a result of previous actions of the applicant.
5. The general intent of the Sign Code.

## **Staff Findings/Recommendations**

Staff does not object to the proposed LED price display. Staff finds that the existing LED price displays on signs in Darien have not presented any problems, nuisances or complaints; there have not been any reports that such signs have caused problems for motorists; the proposed sign meets the general intent of the Sign Code in that the proposed sign is reasonable, orderly and provides an effective display without causing distraction.

Therefore, staff recommends the Planning and Zoning Commission make the following recommendation:

**Based upon the submitted petition and the information presented, the request associated with PZC 20010-09 is in conformance with the standards of the Darien City Code and, therefore, I move the Planning and Zoning Commission recommend approval of the petition, subject to the following conditions:**

- 1. Sign base to be added to sign, so that sign is flush with grade.**
- 2. LED price display is not to blink, flash, flutter, produce varying light intensity or have any other animated graphics.**
- 3. LED illumination brightness to comply with the Sign Code.**

#### **Planning and Zoning Commission Review – July 7, 2010**

The Planning and Zoning Commission considered this matter at their meeting on July 7, 2010. The following members were present: Beverly Meyer – Chairperson, Donald Hickok, Ronald Kiefer, John Lind, Raymond Mielkus, Michael Griffith – Senior Planner and Elizabeth Lahey – Secretary.

The following members were absent: Robert Erickson, Gloria Jiskra, Kenneth Ritzert and Susan Vonder Heide.

Michael Griffith, Senior Planner, reviewed the staff agenda memo. He stated the existing sign is to remain but the petitioner is proposing to replace the existing price display with a LED illuminated display. He stated the City Engineer has reviewed the illumination details and has found that it complies with the Sign Code.

Mr. Griffith stated the petitioner provided information that the sign will not flash, flutter, etc. He noted that several other service stations in the area have similar price displays.

Auna Foote, Corporate ID Solutions, the petitioner, was present. She stated the LED saves money, uses less energy to illuminate and eliminates maintaining/replacing the plastic numbers currently used. She stated the price is changed at 2:00 AM each day.

Chairperson Meyer noted the staff comment to incorporate a base for the sign and if the petitioner had a problem doing it.

Ms. Foote stated putting a base on the sign would not be a problem.

There was not anyone from the public to comment.

**Without further comment, Commissioner Hickok made the following motion seconded by**

**Commissioner Lind:**

**Based upon the submitted petition and the information presented, the request associated with PZC 20010-09 is in conformance with the standards of the Darien City Code and, therefore, I move the Planning and Zoning Commission recommend approval of the petition, subject to the following conditions:**

- 1. Sign base to be added to sign, so that sign is flush with grade.**
- 2. LED price display is not to blink, flash, flutter, produce varying light intensity or have any other animated graphics.**
- 3. LED illumination brightness to comply with the Sign Code.**

**Upon a roll call vote, THE MOTION CARRIED by a vote of 5-0.  
(Absent, Commissioners Erickson, Jiskra, Ritzert and Vonder Heide)**

**Staff Comments - Municipal Services Committee, July 26, 2010**

The City Engineer has determined that the LED illumination meets the Sign Code standards, letter from John Caruso, PE, Christopher B. Burke Engineering, dated July 6, 2010.

The petitioner submitted a revised sign drawing, showing a panel inserted at the sign base.

Based on the Planning and Zoning Commission's recommendation, staff recommends the Committee make the following recommendation:

**Based upon the submitted petition and the information presented, the request associated with PZC 20010-09 is in conformance with the standards of the Darien City Code and, therefore, I move the Municipal Services Committee recommend approval of the petition, subject to the following conditions:**

- 1. LED price display is not to blink, flash, flutter, produce varying light intensity or have any other animated graphics.**

**Municipal Services Committee – Review, July 26, 2010**

The Municipal Services Committee considered this matter at its meeting on July 26, 2010. The following members were present: Alderman Joseph Marchese – Chairperson, Alderman John Galan, Alderman Ted Schauer, Dan Gombac – Director and Elizabeth Lahey – Secretary.

Members absent: Michael Griffith – Senior Planner

Mr. Dan Gombac, Director, presented the staff report. He reported that the petitioner is proposing to replace the existing price display sign with a LED illuminated display. He stated that LED has become popular over the years and that there are a couple of signs in the City who have LED illuminated signs.

Mr. Gombac reported that the petitioner has meet the criteria per the Sign Code and that the PZC recommended approval. He stated that the Committee received a colored copy of the proposed sign and that the ground elevation will be altered to meet the City Code. He stated that the photo displays the old and the new sign.

Ms. Auna Foote, Corporate ID Solutions, explained that daily pricing changes would be updated at 2:00 a.m.

There was no one in the audience wishing to present public comment.

**Alderman Galan made a motion and it was seconded by Alderman Schauer that based upon the submitted petition and the information presented, the request associated with PZC 2010-09 is in conformance with the standards of the Darien City Code and move that the Municipal Services Committee recommend approval of the petition as presented subject to the following:**

**1. LED price display is not to blink, flash, flutter, produce varying light intensity or have any other animated graphics.**

**Upon voice vote, THE MOTION CARRIED unanimously 3-0.**

**CITY OF DARIEN**

**DU PAGE COUNTY, ILLINOIS**

---

**ORDINANCE NO. \_\_\_\_\_**

**AN ORDINANCE APPROVING A VARIATION  
TO THE DARIEN SIGN CODE**

**(PZC 2010-09: 8975 Lemont Road, Circle K/Shell)**

---

**ADOPTED BY THE**

**MAYOR AND CITY COUNCIL**

**OF THE**

**CITY OF DARIEN**

**THIS 2<sup>nd</sup> DAY OF AUGUST, 2010**

---

**Published in pamphlet form by authority of the Mayor  
and City Council of the City of Darien, DuPage  
County, Illinois, this \_\_\_ day of \_\_\_\_\_,  
2010.**



**AN ORDINANCE APPROVING A VARIATION  
TO THE DARIEN SIGN CODE**

**(PZC 2010-09: 8975 Lemont Road, Circle K/Shell)**

-

**WHEREAS**, the City of Darien is a home rule unit of local government pursuant to the provisions of Article VII, Section 6 of the Illinois Constitution of 1970; and

**WHEREAS**, as a home rule unit of local government, the City may exercise any power and perform any function pertaining to its government except as limited by Article VII, Section 6; and

**WHEREAS**, the property legally described in Section 1 (the "Subject Property"), is zoned B-3 General Business District pursuant to the Darien Zoning Ordinance; and

**WHEREAS**, the petitioner has requested approval of a variation from the terms of the Darien Sign Code to allow a LED illuminated price display on an existing free-standing sign; and

**WHEREAS**, a hearing was held before the Planning and Zoning Commission on July 7, 2010, regarding this matter; and

**WHEREAS**, the Planning and Zoning Commission has forwarded its findings and recommendation of approval of this petition to the City Council; and

**WHEREAS**, on July 26, 2010, the Municipal Services Committee of the City Council reviewed the petition and has forwarded its recommendation of approval of this petition to the City Council; and

**WHEREAS**, the City Council has reviewed the findings and recommendations described above and now determines to grant the petition subject to the terms, conditions and limitations described below.

**NOW, THEREFORE, BE IT ORDAINED BY THE CITY COUNCIL OF THE CITY OF DARIEN, DU PAGE COUNTY, ILLINOIS, IN THE EXERCISE OF ITS HOME RULE POWERS**, as follows:

**SECTION 1: Subject Property.** This Ordinance is limited and restricted to the property generally located at 8975 Lemont Road, Darien, Illinois, and legally described as follows:

LOT 1 IN SHELL OIL COMPANY'S ASSESSMENT PLAT, BEING A SUBDIVISION OF PART OF SECTION 5, TOWNSHIP 37 NORTH, RANGE 11, EAST OF THE THIRD PRINCIPAL MERIDIAN, RECORDED DECEMBER 8, 1995, AS DOCUMENT NUMBER R1995-174051, IN DUPAGE COUNTY, ILLINOIS.

PIN: 10-05-105-027

**SECTION 2: Variation from Sign Code Granted.** A variation from the Sign Code, Section 4-3-7(C): Illumination of Signs, is hereby granted to allow a LED price display, in substantial conformance with the following plans:

- A. Sign Drawing, 1 sheet, prepared by Corporate ID Solutions, latest revision dated July 9, 2010.
- B. LED details, 2 sheets, prepared by Corporate ID Solutions and Sign Resource.

**SECTION 3: Condition of Approval.** The variation hereby granted is subject to the following condition:

- A. LED price display is not to blink, flash, flutter, produce varying light intensity or have any other animated graphics.

**SECTION 4: Home Rule.** This ordinance and each of its terms shall be the effective legislative act of a home rule municipality without regard to whether such ordinance should (a) contain terms contrary to the provisions of current or subsequent non-preemptive state law, or (b) legislate in a manner or regarding a matter not delegated to municipalities by state law. It is the intent of the corporate authorities of the City of Darien that to the extent the terms of this ordinance should be inconsistent with any non-preemptive state law, that this ordinance shall supercede state law in that regard within its jurisdiction.

**SECTION 5: Effective Date.** This Ordinance shall be in full force and effect from and after its passage and approval as provided by law.

**PASSED BY THE CITY COUNCIL OF THE CITY OF DARIEN, DU PAGE COUNTY, ILLINOIS**, this 2<sup>nd</sup> day of August, 2010.

AYES: \_\_\_\_\_

NAYS: \_\_\_\_\_

ABSENT: \_\_\_\_\_

**APPROVED BY THE MAYOR OF THE CITY OF DARIEN, DU PAGE COUNTY, ILLINOIS**, this 2<sup>nd</sup> day of August, 2010.

ATTEST:

\_\_\_\_\_  
KATHLEEN MOESLE WEAVER, MAYOR

\_\_\_\_\_  
JOANNE F. COLEMAN, CITY CLERK

APPROVED AS TO FORM:

---

CITY ATTORNEY

## **AGENDA MEMO**

**City Council  
August 2, 2010**

### **ISSUE STATEMENT**

Approval of a resolution authorizing the City to accept a Plat of Dedication for the roadways within the Ashbrook Place Development consisting of Ashbrook Court and a five (5) foot roadway easement (See **Plat** Attachment 1).

### **RESOLUTION**

### **BACKGROUND**

The Ashbrook Homeowners Association requested that the City of Darien take ownership of Ashbrook Court within the Ashbrook Place Development, in October of 2009. The City Council approved a criterion for the acceptance of private roadways in December of 2006.

A motion authorizing City Staff to begin the process of accepting a future Plat of Dedication for the roadways within the Ashbrook Place Development consisting of Ashbrook Court and a five (5) foot roadway easement was approved by the City Council on February 1, 2010.

### **COMMITTEE RECOMMENDATION**

The Municipal Services Committee recommends approval of the resolution to accept a Plat of Dedication for the roadways with the Ashbrook Court Development. The Ashbrook Homeowners Association has complied and completed all items as they relate to the attached February 1, 2010 City Council Meeting Agenda memo. All invoices incurred by the City of Darien have been paid in full.

### **ALTERNATE CONSIDERATION**

Not approving the proposed Plat of Dedication.

### **DECISION MODE**

This item will be placed on the agenda for the August 2, 2010 City Council agenda for formal approval.

**RESOLUTION NO. \_\_\_\_\_****A RESOLUTION TO ACCEPT A PLAT OF DEDICATION FOR ASHBROOK COURT AND CERTAIN PROPERTY**

**WHEREAS**, the Ashbrook Place Residential Association, the owners of certain property commonly known as Ashbrook Court within the Ashbrook Place Subdivision, Darien, DuPage County, Illinois (PIN 09-33-203-059), has executed a Plat of Dedication dedicating certain property that is currently used by the public for public roadway purposes within said Subdivision; and

**WHEREAS**, the Ashbrook Place Residential Association and the seventeen (17) property owners of certain property adjacent to roadways commonly known as Ashbrook Court located within the Ashbrook Place Subdivision, Darien, DuPage County, Illinois (PIN 09-33-203-037, 09-33-203-038, 09-33-203-039, 09-33-203-040, 09-33-203-041, 09-33-203-042, 09-33-203-043, 09-33-203-044, 09-33-203-045, 09-33-203-046, 09-33-203-047, 09-33-203-048, 09-33-203-049, 09-33-203-050, 09-33-203-051, 09-33-203-052, 09-33-203-053, 09-33-203-054, 09-33-203-055, 09-33-203-056, 09-33-203-057 and 09-33-203-058), has executed a Plat of Dedication dedicating certain property that is currently referred to as a common area and private property to be utilized as Public Roadway Easement reserved for and granted to the City of Darien for the perpetual right, privilege and authority to construct, reconstruct, repair, inspect, maintain, and operate a public street, and all necessary personnel and equipment to do any of the above work. The right is also granted to cut down or trim any trees, shrubs or other plants on the easement that interfere with the operation of the road.

**WHEREAS**, The City Council of the City of Darien have determined that it is in the best interests of the City that the formal dedication of such property for public roadway purposes be accepted; and

**NOW, THEREFORE, BE IT RESOLVED BY THE MAYOR AND CITY COUNCIL OF THE CITY OF DARIEN, DU PAGE COUNTY, ILLINOIS**, as follows:

**SECTION 1:** The City of Darien hereby approves said Plat of Dedication, a copy of which is attached hereto as Exhibit A and made a part thereof, and authorizes the Mayor to execute said Plat for and on behalf of the City.

**SECTION 2:** The Ashbrook Place Residential Association have reimbursed the City for all the legal and engineering fees and expenses that the City incurred in connection with the dedication of Ashbrook Court to the City. Said reimbursement to the City of such fees and expenses shall be made prior to the City's recordation of the Plat of Dedication.

**SECTION 3:** Upon the reimbursement of legal and engineering fees and expenses as set forth in Section 2 above, the City Clerk is hereby authorized and directed to take such actions as may be necessary and proper to record the Plat of Dedication with the DuPage Recorder of Deeds.

**SECTION 4: Home Rule.** This Resolution and each of its terms shall be the effective legislative act of a home rule municipality without regard to whether such Resolution should (a) contain terms contrary to the provisions of current or subsequent non-preemptive state law, or (b) legislate in a manner or regarding a

matter not delegated to municipalities by state law. It is the intent of the corporate authorities of the City of Darien that, to the extent the terms of this Resolution should be inconsistent with any non-preemptive state law, this Resolution shall supersede state law in that regard within its jurisdiction.

**SECTION 5: Effective Date.** This Resolution shall be in full force and upon its passage and approval as required by law.

**PASSED BY THE CITY COUNCIL OF THE CITY OF DARIEN, DU PAGE COUNTY, ILLINOIS,** this 2<sup>nd</sup> day of August 2010.

AYES: \_\_\_\_\_

NAYS: \_\_\_\_\_

ABSENT: \_\_\_\_\_

**APPROVED BY THE MAYOR OF THE CITY OF DARIEN, DU PAGE COUNTY, ILLINOIS,** this 2<sup>nd</sup> day of August 2010.

\_\_\_\_\_  
KATHLEEN MOESLE WEAVER, MAYOR

ATTEST:

\_\_\_\_\_  
JOANNE F. COLEMAN, CITY CLERK

APPROVED AS TO FORM:

\_\_\_\_\_  
CITY ATTORNEY

**AGENDA MEMO****City Council****August 2, 2010****ISSUE STATEMENT**

A resolution authorizing the Mayor to accept a proposal from Omni Pump Repairs for the City's water system in an amount not to exceed \$15,800.00 to re-build internal critical components of three pumps at Plant Two-1220 Plainfield Road.

**RESOLUTION****BACKGROUND/HISTORY**

The proposed expenditure is for the maintenance of the City's water variable speed water pumps. The pumps are independent inline components of the water system utilized to deliver potable water to maintain pressures. The pumps maintain lubrication through the City's water system and are inspected on a daily basis. The visual inspection consists of water that should be "dripping" at both pump bearings. Through normal wear and tear the bearings become worn and the "dripping" develops into a "stream" indicating that the pumps require servicing. The pumps were installed in 1992 and have not been re-built since.

Staff is requesting a contingency amount not to exceed \$5,000 for internal parts or machining if required.

The City has requested competitive quotes for the rebuilding of the two forty horsepower pumps, and has received four responses.

VENDOR	UNIT	UNIT PRICE	NO OF PUMPS	COST	CONTINGENCY	PROPOSED EXPENDITURE WITH CONTINGENCY
Gasvoda and Associates	EACH	\$ 7,824.00	2	\$15,648.00	\$ 5,000.00	\$ 20,648.00
Gasvoda and Associates	EACH	\$ 8,017.00	1	\$ 8,017.00	0	\$ 8,017.00
<b>TOTAL FOR GASVODA AND ASSOCIATES</b>		<b>\$15,841.00</b>	<b>3</b>	<b>\$23,665.00</b>	<b>\$ 5,000.00</b>	<b>\$ 28,665.00</b>
General Pump and Machinery	EACH	\$ 4,573.33	3	\$13,720.00	\$ 5,000.00	\$ 18,720.00
Metropolitan Pump Company	EACH	\$ 9,535.00	2	\$19,070.00	\$ 5,000.00	\$ 24,070.00
Metropolitan Pump Company	EACH	\$ 9,535.00	1	\$ 9,535.00	0	\$ 9,535.00
<b>TOTAL FOR METROPOLITAN PUMP</b>		<b>\$19,070.00</b>	<b>3</b>	<b>\$28,605.00</b>	<b>\$ 5,000.00</b>	<b>\$ 33,605.00</b>
<b>Omni Pump Repairs</b>	<b>EACH</b>	<b>\$ 3,600.00</b>	<b>3</b>	<b>\$10,800.00</b>	<b>\$ 5,000.00</b>	<b>\$ 15,800.00</b>

References for the proposed awarded vendor, Omni Pump Repairs have been verified with very good responses.

The budgeted expenditure would be expended from the following account:

ACCOUNT NUMBER	ACCOUNT DESCRIPTION	FY 09-10 BUDGET	YEAR TO DATE PROPOSED EXPENDITURE	PROPOSED EXPENDITURE	PROPOSED BALANCE

02-50-4815	Equipment Pump Repairs-Plant Two	\$29,299.00	\$ 0	\$ 10,800.00	\$ 18,499.00
02-50-4815	Equipment Pump Repairs-Plant Two-CONTINGENCY	\$18,499.00	\$ 10,800.00	\$ 5,000.00	\$ 3,070.60

**COMMITTEE RECOMMENDATION**

The Municipal Services Committee recommends accepting a proposal from Omni Pump Repairs in an amount not to exceed \$15,800.00 for maintenance repairs for three pumps as specified.

**ALTERNATE DECISION**

As recommended by the Committee.

**DECISION MODE**

This item will be placed on the August 2, 2010 City Council agenda for formal consideration.



**RESOLUTION NO.** \_\_\_\_\_

**A RESOLUTION AUTHORIZING THE MAYOR TO ACCEPT A PROPOSAL FROM OMNI PUMP REPAIRS IN AN AMOUNT NOT TO EXCEED \$15,800.00 TO RE-BUILD INTERNAL CRITICAL COMPONENTS OF THREE PUMPS LOCATED AT PLANT TWO-1220 PLAINFIELD ROAD**

**BE IT RESOLVED BY THE CITY COUNCIL OF THE CITY OF DARIEN, DU PAGE COUNTY, ILLINOIS**, as follows:

**SECTION 1:** The City Council of the City of Darien hereby authorizing the Mayor to accept a proposal from Omni Pump Repairs in an amount not to exceed \$15,800.00 to re-build critical components of three pumps located at Plant Two-1220 Plainfield Road, a copy of which is attached hereto as "[Exhibit A](#)" and is by this reference expressly incorporated herein.

**SECTION 2:** This Resolution shall be in full force and effect from and after its passage and approval as provided by law.

**PASSED BY THE CITY COUNCIL OF THE CITY OF DARIEN, DU PAGE COUNTY, ILLINOIS**, this 2<sup>nd</sup> day of August 2010.

**AYES:** \_\_\_\_\_

**NAYS:** \_\_\_\_\_

**ABSENT:** \_\_\_\_\_

**APPROVED BY THE MAYOR OF THE CITY OF DARIEN, DU PAGE COUNTY, ILLINOIS**, this 2<sup>nd</sup> day of August 2010.

\_\_\_\_\_  
KATHLEEN MOESLE WEAVER, MAYOR

ATTEST:

\_\_\_\_\_  
JOANNE F. COLEMAN, CITY CLERK

APPROVED AS TO FORM:

\_\_\_\_\_  
CITY ATTORNEY



9224 CHESTNUT AVENUE • FRANKLIN PARK, ILLINOIS 60131  
(847) 451-0000 • FAX (847) 451-0119

## PROPOSAL

June 23, 2010

Quote: #11605  
Revised

City of Darien  
1220 Plainfield Rd.  
Darien, IL. 60561

Attn: Clark

Re: Weinman Horizontal Split Case Pump

Dear Mr. Clark,

We are pleased to submit our proposal to overhaul the above pump. The overhaul will include a base repair. The base repair includes the replacement of standard wearable components. A detailed description of these components follows.

We propose to utilize the following parts and services:

### NEW PARTS:

- Sleeve Material CA 932 Bronze
- Glands/Gland Bolts will be machine polished
- Case/Wear Rings will be machine polished and checked for proper concentricity
- Bearings for pump will be included
- Mechanical Seal
- Necessary Gaskets, O-Rings, Nuts, Bolts and Washers
- Shaft Material 416 S.S.
- Two (2) CA932 Bronze Casing Rings

Above we label the raw materials used for the shaft and sleeves. We will machine these components in our facilities. All dimensions are documented upon disassembly. All components are machined within OEM specifications.

# OMNI-PUMP REPAIRS, INC.

## SERVICES:

- Disassembly and inspection
- Cleaning by solvents and/ or sandblasting
- Reassemble and checking clearances
- All rotating elements are dynamically balanced
- Pump housings will be painted
- Delivery to your facilities
- Installation

## NOTE:

*The below stated cost includes all of the above stated materials, parts and services. If upon disassembly our technicians find any internal components damaged outside of the above stated work scope your facilities will be notified with the appropriate corrective measures.*

## COST:

The cost for the above stated work will be.....\$3,600.00 ea.

## DELIVERY:

The time required for the above work, after release, is estimated at 1-2 weeks.

## WARRANTY:

Omni-Pump Repairs, Inc offers a one (1) year warranty on materials and ninety (90) days on labor from the date of installation.

## Terms:

Invoices are due and expected payable in full within thirty (30) days from date of invoice. Past due invoice are subject to late payment service charges of 1 1/2% per month. A service charge of \$100.00 will be applied to each returned check. Accounts 61 days old will be placed on COD. Legal Action will be taken after account is 90 days old.

## Returns:

No returned goods will be accepted without an assigned return authorization number and freight charges must be prepaid. Goods returned for credit must show an invoice number.

A handling or restocking charge, a minimum of 20%, will be made on all good returned.

# OMNI-PUMP REPAIRS, INC.

Failure to Pay:

Failure by customer to pay any part of the purchase price when due, or in the event that proceedings in bankruptcy, receivership, or insolvency by or against Customer or his property, Supplier may, at its option, cause the entire unpaid balance to become due and immediately payable and Supplier shall have the right to enter at any time without notice upon premises where any of the materials purchased by the Customer are located.

Customer hereby expressly waives any right to action which may accrue by reason of the entry for taking possession of or the selling of said materials and agrees to pay all costs incurred with respect thereto including service charges and reasonable attorney's fees and court costs.

This agreement covers all materials which customer may hereafter acquire at anytime from Supplier. This contract constitutes the entire agreement with Supplier. No waivers or modifications shall be valid unless the same are in writing and executed by the parties hereto. This contract shall apply and accrue to the benefit of, and be binding upon, the heirs, executors, administrators, successors, and assigns of the respective parties.

In the event of any litigation arising out of this agreement, Supplier shall be entitled to its reasonable costs and expenses incurred including attorney fees.

This Purchase Agreement shall be governed by the laws of the State of Illinois.

Customer hereby acknowledges the receipt of a copy of this Agreement at time of its execution.

Accepted by Customer:

Name: \_\_\_\_\_  
Position/Title: \_\_\_\_\_  
Purchase Order #: \_\_\_\_\_

Accepted by Supplier:

Name: Pete Moraitis  
Position/Title: General Manager  
Date Accepted: 6/23/2010

We are confident that we can repair the above pump very effectively and economically. We look forward to receiving your valued purchase order on this project as well as on any other project that you may have in the future.

Please let us know if you need additional information or clarification on our repair procedures or overall capabilities.

Best Regards, Pete Moraitis/General Manager

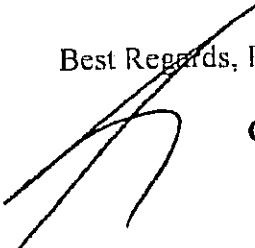

CHECK US OUT AT: [www.FURAINTERNATIONAL.com](http://www.FURAINTERNATIONAL.com)

**AGENDA MEMO**

**City Council  
August 2, 2010**

**ISSUE STATEMENT**

A resolution authorizing the purchase of one (1) new Asphalt Box Trailer from Bonnell Industries, Inc. in the amount of \$17,945.00.

**RESOLUTION****BACKGROUND/HISTORY**

The proposed asphalt trailer would be replacing a 1998 asphalt unit. The unit would be utilized for hot and cold asphalt pot hole patching throughout the year.

Below please find a summary of the three sealed bids received on July 19, 2010 for the purchase of the Asphalt Box Trailer.

VENDOR	MODEL DESCRIPTION	PRICE QUOTED
Asphalt Maintenance & Construction	KM International Inc Model KM 4000TEDX	\$25,127.60
Stepp Manufacturing Co.	STEPP SPH 1.5	\$20,116.00
<b>Bonnell Industries Inc</b>	<b>Spaulding 2T Road Saver</b>	<b>\$17,945.00</b>

The current budget included funds for the proposed equipment and would be expensed from the following line account:

ACCOUNT NUMBER	ACCOUNT DESCRIPTION	FY 10/11 BUDGET	PROPOSED EXPENDITURE	PROPOSED BALANCE
01-30-4815	EQUIPMENT- ASPHALT BOX WITH TRAILER	\$22,260.00	\$ 17,945.00	\$ 4,315.00

**COMMITTEE RECOMMENDATION**

The Municipal Services Committee recommends approval of the resolution authorizing the purchase one (1) new Asphalt Box Trailer from Bonnell Industries, Inc. in the amount of \$17,945.00.

**ALTERNATE DECISION**

As recommended by the Committee.

**DECISION MODE**

This item will be placed on the August 2, 2010 City Council agenda for formal consideration.

**RESOLUTION NO.** \_\_\_\_\_

**A RESOLUTION AUTHORIZING THE PURCHASE OF ONE NEW ASPHALT HOTBOX TRAILER FROM BONNELL INDUSTRIES IN THE AMOUNT OF \$17,945.00**

**BE IT RESOLVED BY THE CITY COUNCIL OF THE CITY OF DARIEN, DU PAGE COUNTY, ILLINOIS,** as follows:

**SECTION 1:** The City Council of the City of Darien hereby authorizes a purchase of one (1) new Asphalt Hotbox Trailer from Bonnell Industries, Inc. in the amount of \$17,945.00, a copy of which is attached hereto as "[Exhibit A](#)" and is by this reference expressly incorporated herein.

**SECTION 2:** This Resolution shall be in full force and effect from and after its passage and approval as provided by law.

**PASSED BY THE CITY COUNCIL OF THE CITY OF DARIEN, DU PAGE COUNTY, ILLINOIS,** this 2<sup>nd</sup> day of August 2010.

**AYES:** \_\_\_\_\_

**NAYS:** \_\_\_\_\_

**ABSENT:** \_\_\_\_\_

**APPROVED BY THE MAYOR OF THE CITY OF DARIEN, DU PAGE COUNTY, ILLINOIS,** this 2<sup>nd</sup> day of August 2010.

\_\_\_\_\_  
KATHLEEN MOESLE WEAVER, MAYOR

ATTEST:

\_\_\_\_\_  
JOANNE F. COLEMAN, CITY CLERK

APPROVED AS TO FORM:

\_\_\_\_\_  
CITY ATTORNEY



# CITY OF DARIEN

In the County of DuPage and the State of Illinois  
Incorporated 1969

## CITY OF DARIEN - EQUIPMENT SPECIFICATIONS

### BID RESPONSE FORM

BID DATE JULY 19, 2010 10:00AM

1702 PLAINFIELD ROAD

DARIEN, ILLINOIS 60561

COMPANY NAME: Bonnell Industries, Inc.

ADDRESS: 1385 Franklin Grove Rd

CITY: Dixon STATE: IL ZIP: 61021

PHONE NUMBER: 800-851-9664 FAX NUMBER: 815-284-8815

PERSON EXECUTING THE CONTRACT: Norm Stoiber

TITLE: Sales Representative

BASE BID FOR ONE (1) NEW 2010 ASPHALT HOTBOX TRAILER WITH EQUIPMENT PACKAGE INCLUDING ALL BODY OPTIONS, LIGHTING, ACCESSORIES, HYDRAULICS, AND CONTROLS, AS PER THE ATTACHED SPECIFICATIONS

MAKE: SPAULDING

MODEL: 2T ROAD SAVER

TOTAL NET PRICE FOR: \$ 17,945.00

TOTAL NUMBER OF DAYS FOR THE EQUIPMENT TO BE DELIVERED, AFTER RECEIVING PURCHASE ORDER FROM CITY OF DARIEN.

90 - 120 DAYS

SIGNATURE OF BIDDER: Norm Stoiber DATE: 7/18/2010

TITLE: SALES. REP.

THE ABOVE AGREES TO HOLD THE ABOVE PRICING FOR NINETY (90) DAYS.

\*\*ALL BIDS MUST BE RETURNED IN A SEALED ENVELOPE AND CLEARLY LABELED - 2010 ASPHALT HOTBOX TRAILER

## **Specifications for**

### **Asphalt Hotbox Trailer Unit – Diesel Fired**

#### **General Description**

This specification describes one (1) trailer-mounted, 2 ton capacity Asphalt Hotbox. This unit will be used primarily to transport and maintain the temperature of hot-mix asphalt material for extended time periods. With the optional low temp switch, the unit will heat cold-mix patch to a usable consistency for pot-hole patching operations during cold weather months.



**COMPLIES WITH SPECIFICATIONS**  
**GENERAL**

One (1) trailer-mounted, two-ton capacity, asphalt hotbox, electric brakes and diesel heated.

Yes  No

Allows hot mix asphalt to be kept at working temperature for a minimum of 40 hours without refueling.

Yes  No

Capable of heating cold patch asphalt mix to a workable consistency during cold weather operations.

Yes  No

**PAINT**

All exposed pieces shall be properly prepared and painted yellow. All raw materials shall be new, unused, and properly coated with an industrial equipment primer and industrial equipment paint coating.

Yes  No

**TECHNICAL/PARTS MANUAL**

One (1) service, repair and parts manual shall be provided.

Yes  No

**WARRANTY**

One (1) year manufacturer's warranty.

**WARRANTY DOCUMENTATION PROVISIONS**

**General Terms and Conditions:** Warranty certificates or letters on all applicable and requested warranty items shall be provided upon delivery of the unit. All warranties shall start from the "received by customer" date.

Yes  No

**OVERALL DIMENSIONS**

234" Long x 96" Wide x 78" High

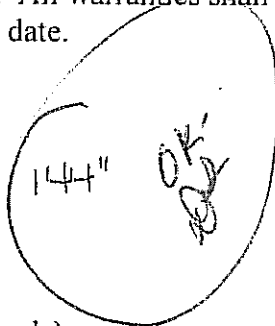

Yes  No

**STORAGE CAPACITY**

4,000 pounds of asphalt (2.46 cubic yards)

Yes  No

**TRAILER**

The heavy duty trailer frame shall be constructed with a minimum of 6" x 8.2 lbs/ft channel steel outer frame, front and rear cross members and 4" x 5.4 lbs/ft channel steel interior cross members.

Yes  No

WE WILL USE TUBING FOR  
ADDED STRENGTH.

**TRAILER - Continued**

12

The trailer tongue shall have a 7 position adjustable hitch complete with 3" I.D. pintle ring rated at 20k lbs and two (2) 3/8" Class III safety chains with grab hooks. Yes X No     

Two (2) 7,000 lb axles and 24" five leaf, slipper spring suspension. Yes X No     

12V electric brakes on all wheels, with emergency breakaway feature. Yes X No     

Tires indicating the US DOT Tire Identification Number (required by DOT after 01/01/2008) shall be used. Yes X No     

Fenders shall be permanently attached heavy duty, 3/16" tread plate. Yes X No     

One heavy-duty screw jack pad (5,000 lb minimum capacity). Yes X No     

Shovel Rack: permanently attached, holster type brackets shall be included on the outer shell of the unit for storage of two (2) standard asphalt shovels. Yes X No     

The front frame of the trailer shall enclose a utility area with a deck constructed of 3.0 lbs. at 300 lbs/sf braced expanded metal grating. Yes X No     

Trailer Lighting: DOT approved running lights; reflective tape; 4 circular rear-mounted stop/turn/tail lights on rear trailer frame; and 2 oval stop/turn/tail lights mounted on the outside fenders. Yes X No     

**ASPHALT COMPARTMENT**

Construction: Continuous welded steel, triple wall construction, 16-gauge skin, 12-gauge sloped tubular steel reinforced walls asphalt compartment. Yes X No       
*IN FRONT AND REAR*

*EXCEEDS* Dimensions of storage bin: length 60" x width 64" x height 40" Yes X No X  
*59" / 81" / 50" OK*

Insulation: Minimum 2" of high efficiency fiberglass insulation Plus reflective metal sheeting shall line the entire exterior walls. Loading doors shall have a minimum of 3" high energy efficient insulation. Yes X No X

*WALLS MEET / CONFIRMED*

*DOORS 1"*

*NOT USED IN DOORS TO SAVE ON WEIGHT.*

*OK DJ*

**ASPHALT COMPARTMENT - Continued**

Loading Doors: Two loading doors shall include cantilevered Handles assisted by a gas loaded shock on each door. Minimum lifting weight 15 lbs of force to open. The doors shall form a chute to assist in placing the patch material in the hopper. Safety latches shall be provided which will not allow the lids to close without the user manually disengaging the safety latch.

Yes X No X

OPEN by GAS SHOCK - Better  
NOT CANTILEVERED ok

Asphalt hopper wall shall be sloped, funneling the contents toward the unloading doors. Shall be free on any structures such as air ducts that would cause asphalt damming.

Yes X No    

Two unloading (shovel ports) doors shall be located at the Rear of the unit, and shall slide open to allow the heated Asphalt to be shoveled.

Yes X No    

Each shoveling port must be large enough to accommodate A standard use asphalt shovel, and shall be a minimum of 20" width by 16" high.

Yes X No    

**HEATING TYPE/SOURCE**

The asphalt storage compartment is to be heated by a diesel-fired type burner, rating to be a minimum of 105,000 BTU. Diesel burner is mounted above the trailer frame within the chassis. Unit enclosed in protective removable cover to keep burner and components clear of road grime and salt.

Yes X No X

FLUSH WITH BOTTOM OF BOX  
EASY REPLACEMENT SLIP IN  
AND OUT - NO TORCHING!  
ok

The diesel burner shall be equipped with an automatic electronic ignition system and a 100% safety "Failure to Ignite" shut down feature with a manual reset.

Yes X No    

Primary combustion air shall be provided to the diesel burner for ignition and heating by means of a 12V self contained blower.

Yes X No    

High temperature probe to monitor combustion area temperature with adjustable digital high temp shut down controller.

Yes X No    

Diesel burner heating system shall be thermostatically controlled with temperature settings adjustable from 100 to 350 degrees Fahrenheit.

Yes X No    

Asphalt chamber monitored by digital readout thermometer.

Yes X No

**HEATING TYPE/SOURCE – Continued**

The heating system shall be supplied power by a 12V deep cycle marine gel battery, charged through the towing vehicle charging system and equipped with overnight 110V charging system supplied with the unit.

Yes  No

A minimum 25-gallon diesel fuel tank shall be incorporated To provide a fuel source for the heating system.

Yes  No

**OPTIONAL ITEMS**

**Liquid Tack Tank:** A heated 30 gallon liquid tack tank shall be constructed with triple wall and insulated to aid in heating efficiency, with the bottom receiving additional insulating measures to protect from overheating the tack material. A one-inch (1”) on/off ball type valve with spout will supply the material. The lid will be a weather resistant enclosure attached by hinge with lockable latch. A 10,000 BTU LP burner shall be thermostatically controlled from zero to one hundred fifty (0 – 150) degrees Fahrenheit. The ability to lock a maximum temperature setting in order to avoid overheating will be included in the thermostat. A one hundred (100%) percent safety shut-off feature shall be standard.

Yes  No

**Low Temperature Switch and Thermostat:** A toggle switch will be mounted in the control panel which allows the operator to select between the standard temperature controller and the optional low temperature (60° F to 250°F) thermostat.

Yes  No

**Liquid Utility Tank:** A seven (7) gallon capacity utility tank shall be supplied for use with solvents and alike. A one-inch (1”) bottom outlet will be supplied. The tank will allow standard asphalt shovels to be “dipped” inside for cleaning.

Yes  No

**Utility Torch:** One 50,000 BTU handheld torch with 15’ hose. The torch shall receive its fuel supply from a 30-lb (minimum) LP gas cylinder, securely mounted at the front of the trailer unit. The cylinder shall be secured safe for travel and removable as necessary. U.L. rated L.P. gas hosing along with safety valve shall be included. The torch shall have (3/8” approved quick coupling) connections located at the rear of the unit making it nearest the normal working area. A manual lighting procedure will be required for ignition. An on/off needle valve shall be attached to the torch.

Yes  No

**Tool Rack:** Minimum six (6) implements; upright mounted in utility area; constructed of steel angle iron.

Yes

No

**Dump Box:** The hotbox body will be fabricated with an additional 6" (six inch) @ 8.2 pound structural channel steel support frame and hydraulic scissors hoist. The scissor hoist will be a minimum of 16,000# capacity. The hoist will be operated by means of a 12 volt electric pump with integral oil reservoir and push button operator with 10 ft. cord. The push button operator will have a lockable storage box to prevent unauthorized access. The box will dump up to a minimum of 45 degree. The hotbox will have a manual dump body prop rod built into the trailer frame. The unit will be supplied with a prewired 12 volt battery and towing vehicle charging system as well as separate 110 volt/12 volt battery charger for overnight charging.

Yes

No

**Warning Signal:** Proper wiring and brackets will be provided for safety marking equipment. Arrow warning light is switched to allow the user to warn and/or direct the arrow left, right, bar or left and right. Safety beacon light will be switched to allow the user to turn the light on or off. Switch location will be in the control panel of the main heating unit. Specifications must be supplied with purchase order to Determine the correct safety light(s).

Yes

No

**AGENDA MEMO****City Council****August 2, 2010****ISSUE STATEMENT**

A resolution authorizing the purchase of one new Nine Ton Dovetail Trailer, from A&W Truck and Trailer in the amount of \$6,555.00.

**RESOLUTION****BACKGROUND/HISTORY**

The proposed trailer is a replacement for a 1974 Centerville Trailer-Unit 301. The proposed trailer is to be utilized for transporting material such as pipe, concrete manhole structures, sod and larger bulkier items. The FY10-11 budget included the funding for the proposed trailer.

Staff had requested competitive quotes for the trailer and received three. Below please find the results of the competitive quotes for the Nine Ton Dovetail Trailer.

VENDOR	MODEL NO	COST
<b>A &amp;W Auto Truck Trailer</b>	9 Ton Dovetail Trailer	<b>\$ 6,555.00</b>
Wackerline Trailer	9 Ton Dovetail Trailer	\$ 6,615.00
R. A. Adams Enterprises	9 Ton Dovetail Trailer	\$ 6,595.00

The proposed item would be expended from the following account:

ACCOUNT NUMBER	ACCOUNT DESCRIPTION	FY 10-11 BUDGET	YEAR TO DATE EXPENDED	PROPOSED EXPENDITURE
01-30-4815	Equipment-Trailer Unit 301	\$ 6,500.00	\$ -0-	\$ 6,500.00

**Committee Recommendation**

The Municipal Services Committee recognizes there is a \$55.00 shortfall in comparison to the budgeted amount. The deficit would be reimbursed from a savings realized earlier in the year from the Equipment Account. The Committee recommends approval of the resolution authorizing the purchase of one new Nine Ton Dovetail Trailer, from A&W Truck and Trailer in the amount of \$6,555.00.

**Alternate Consideration**

Not approving this item at this time.

**Decision Mode**

This item will be placed on the August 2, 2010 City Council agenda for formal consideration.

**RESOLUTION NO.** \_\_\_\_\_

**A RESOLUTION AUTHORIZING THE PURCHASE OF ONE NEW NINE TON DOVETAIL TRAILER FROM A & W TRUCK AND TRAILER IN THE AMOUNT OF \$6,555.00**

**BE IT RESOLVED BY THE CITY COUNCIL OF THE CITY OF DARIEN, DU PAGE COUNTY, ILLINOIS,** as follows:

**SECTION 1:** The City Council of the City of Darien hereby authorizes a purchase from A & W Truck and Trailer in the amount of \$6,555.00 for one new Nine Ton Dovetail Trailer, a copy of which is attached hereto as "[Exhibit A](#)" and is by this reference expressly incorporated herein.

**SECTION 2:** This Resolution shall be in full force and effect from and after its passage and approval as provided by law.

**PASSED BY THE CITY COUNCIL OF THE CITY OF DARIEN, DU PAGE COUNTY, ILLINOIS,** this 2<sup>nd</sup> day of August 2010.

**AYES:** \_\_\_\_\_

**NAYS:** \_\_\_\_\_

**ABSENT:** \_\_\_\_\_

**APPROVED BY THE MAYOR OF THE CITY OF DARIEN, DU PAGE COUNTY, ILLINOIS,** this 2<sup>nd</sup> day of August 2010.

\_\_\_\_\_  
KATHLEEN MOESLE WEAVER, MAYOR

ATTEST:

\_\_\_\_\_  
JOANNE F. COLEMAN, CITY CLERK

APPROVED AS TO FORM:

\_\_\_\_\_  
CITY ATTORNEY

# ORDER / QUOTE FORM

NO. \_\_\_\_\_

CUSTOMER:

CITY OF DARIEN

DAVE FELL

PHONE: 630-429-1711

FAX: 630-887-0091

## A&W Auto Truck & Trailer

17W411 North Frontage Road  
Darien, IL 60561

(630) 964-8897

(800) 258-6408

Fax (630) 964-4644

Date: 06-29-2010

Serial #: \_\_\_\_\_

P.O. # \_\_\_\_\_

RICE

### STANDARDS:

MODEL #	9-TON TRIAXLE 20'x5'
Axle	3-7000#
Brakes	ELECT (3) 12" x 2"
Hitch	ADJUSTABLE PINTLE 3"
Jack	2- 12000# DROP FOOT w/SAID PAD.
Tires	ST235-80-R16 10PLY RADIALS
Wheels	8-BOLT
Frame	12" I-BEAM w/DECK BRACES
Floor	2XB TREATED
CXM's	16" O.C. - 3" CHANNEL
Sidewall	STAKE POCKETS w/ RUB RAILS
Side Door	_____
Rear Door	_____
Rear Ramps	5 FT. FOLD OVER - FLUSH w/ JACK
Color Body	CHOICE OF STANDARD
Wrap & Cap	_____
Inside Height	_____
Inside Length	20 FT. FLAT 5 FT. DOVE TAIL DOT. SEAL BEAM LIGHTS FOLD-OVER FLUSH RAMPS. SPRING ASSISTED 5 FT.

1. 102" WIDE
2. E-Z LUBE HUBS.
3. \_\_\_\_\_
4. \_\_\_\_\_
5. STORAGE PAN IN TONGUE
6. BETWEEN JACKS.
7. \_\_\_\_\_
8. MUD FLAPS. 1 PR.
9. \_\_\_\_\_
10. SELF CLEANING DOVE TAIL
11. & RAMPS.
12. \_\_\_\_\_
13. SLIPPER SPRING SUSPENSION
14. \_\_\_\_\_
15. \_\_\_\_\_
16. 3 YR. WARRANTY MAIN FRAME
17. 1 YR ALL OTHER COMPONENTS.
18. \_\_\_\_\_
19. \_\_\_\_\_
20. \_\_\_\_\_

\$ 6415<sup>00</sup>

### TRAILER PRINT NEEDED

YES

NO

Sales Tax - 0 -

License & Title 10<sup>00</sup> 95<sup>00</sup>

Doc. Fee 35<sup>00</sup>

TOTAL 6555<sup>00</sup>

"M" PLATE

RECEIVED: \_\_\_\_\_

DATE: \_\_\_\_\_



**AGENDA MEMO**  
**City Council**  
**August 2, 2010**

**ISSUE STATEMENT**

A resolution authorizing the City Administrator to enter into an agreement between the City of Darien and Tri-State Fire Protection District to place radio antennas on the tower located at 1041 S. Frontage Road.

[RESOLUTION](#)

[BACKUP](#)

**BACKGROUND/HISTORY**

The City of Darien was transferred ownership of an antenna tower at the Municipal Services facility by the University of Chicago fifteen years ago. There are currently antennas owned by T-Mobile on the tower, with a contract ready to expire in 2011. Other commercial vendors have not been interested in the site when they were asked because of its positioning. There is also equipment for SEDCOM and DuComm on the tower.

The Tri-State Fire Protection District has requested they be provided permission to add communication facilities to the tower. This would provide upgraded radio communication through the Tri-State district for their emergency responders. They would be using a lower sidearm mount and space on the tower that could be used by another vendor, however. At the June 14, 2010 Administrative/Finance Committee meeting the committee recommended this equipment should be allowed to be mounted at no charge.

**STAFF/COMMITTEE RECOMMENDATION**

The Administrative/Finance Committee recommends approving this agreement.

**ALTERNATE CONSIDERATION**

Not approving the agreement would be an alternate consideration.

**DECISION MODE**

This item will be on the August 2, 2010 City Council meeting agenda for formal approval.

**A RESOLUTION AUTHORIZING THE CITY ADMINISTRATOR TO ENTER INTO AN AGREEMENT WITH TRI-STATE FIRE PROTECTION DISTRICT TO PLACE RADIO ANTENNAS ON THE TOWER LOCATED AT 1041 S. FRONTAGE RD**

**BE IT RESOLVED BY THE CITY COUNCIL OF THE CITY OF DARIEN, DU PAGE COUNTY, ILLINOIS**, that the City Administrator is authorized enter into an agreement with Tri-State Fire Protection District to place radio antennas on the tower located at 1041 S. Frontage Road, a copy of which is attached hereto as "[Exhibit A](#)".

**PASSED BY THE CITY COUNCIL OF THE CITY OF DARIEN, DU PAGE COUNTY, ILLINOIS**, this 2<sup>nd</sup> day of August, 2010.

AYES: \_\_\_\_\_

NAYS: \_\_\_\_\_

ABSENT: \_\_\_\_\_

**APPROVED BY THE MAYOR OF THE CITY OF DARIEN, DU PAGE COUNTY, ILLINOIS**, this 2<sup>nd</sup> day of August, 2010.

ATTEST:

\_\_\_\_\_  
KATHLEEN MOESLE WEAVER, MAYOR

\_\_\_\_\_  
JOANNE F. COLEMAN, CITY CLERK

APPROVED AS TO FORM:

\_\_\_\_\_  
CITY ATTORNEY

EXISTING SEDCOY/  
NOPAGE UHF  
ANTENNA  
Tower Top  
(OUTSHOWN)

Proposed - VHF Antenna  
#1

3' MW  
DISH

Existing Wireless  
Array's

VHF ANTENNA  
#2

VHF Antenna  
#3

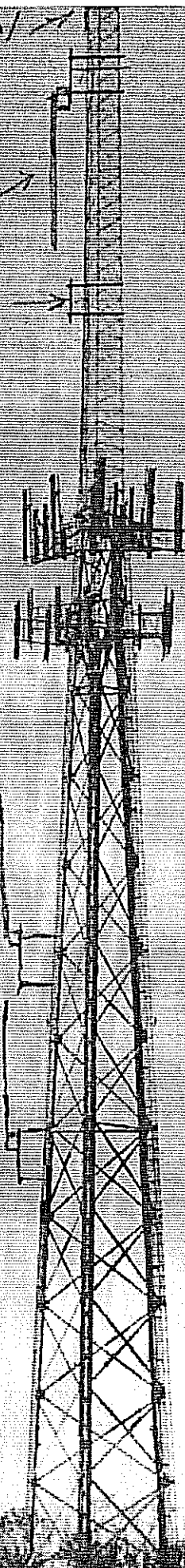

# Exposed Dipole Quasi-Omni Antenna

138 - 174 MHz & 220 - 285 MHz / 6 or 9 dBd Gain



DB224

This popular antenna is available with four folded dipoles for high gain and broad bandwidth. MODEL DB224 is a high gain, lightweight, high strength antenna for use in the 138-285 MHz band. It is factory adjusted and checked for minimum VSWR over a wide band of frequencies. Clamps for top mounting are supplied with the antenna but an additional side mount kit (Model DB5001) must be ordered when side mounting the antenna.

• **Broad Response** — 10 MHz bandwidth provides optimum performance in single or multi-frequency systems, on both transmit and receive. Unique model, DB224-FAA, available for most VHF air control systems.

• **Optional Radiation Pattern** — The radiation pattern of the DB224 can be easily changed from a 6 dB gain omni-directional pattern, to a 9 dB maximum gain offset pattern, or from an offset to an omni-directional pattern. When the four-dipole elements are positioned evenly, every 90 degrees around the mast, a circular radiation pattern results. When all four dipoles are in line (collinear) along one side of the mast, the antenna has a directional characteristic.

**Bandwidth** — Through the use of folded dipole elements and binary cable harness, the DB224 has an exceptionally broad bandwidth. Performance characteristics (gain, VSWR) are essentially constant over a frequency range of 10 MHz or more. This permits the DB224 to provide optimum performance when used in either single or multi-frequency systems.

**Two-Piece Mast** — For ease of handling and to facilitate shipment, the mast is made in two sections. Assembly of the sections is quite simple and requires only the use of ordinary hand tools. The unique center splice assures proper alignment.

• **Split Version** — The DB224S is a split version of the DB224. It consists of two independent antennas on the same mast; each with a separate feedline terminated at the bottom of the mast. Essentially it amounts to two 3 dB gain in an omni-directional pattern (DB224S) or two 6 dB gain in an offset pattern (DB224ES). Each antenna may be used omni-directionally or directionally without regard to the other. Isolation between the two antennas is 35 dB or more.

• **Lightning Resistant** — The radiators operate at DC ground, and the aluminum mast, with its pointed cap, provides a low resistant discharge path to the tower or ground system.

• **For Air Shipment** — Model DB224X, refer to table.



Simple but secure stainless steel banding clamp allows an easy change from circular to offset radiation pattern.



Molded connections for weatherproof operation.

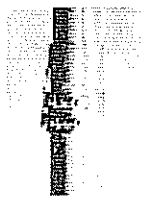

Unique center splice prevents misalignment; two piece construction for easier handling before installation.

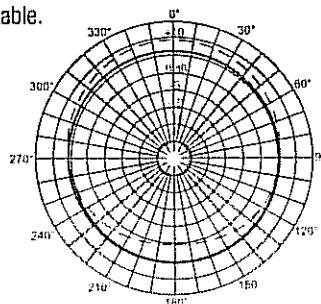

Horizontal patterns illustrate the maximum gain of the DB224 (6 dB) and DB224E (9 dB) with respect to a half wave dipole (0 dB level).

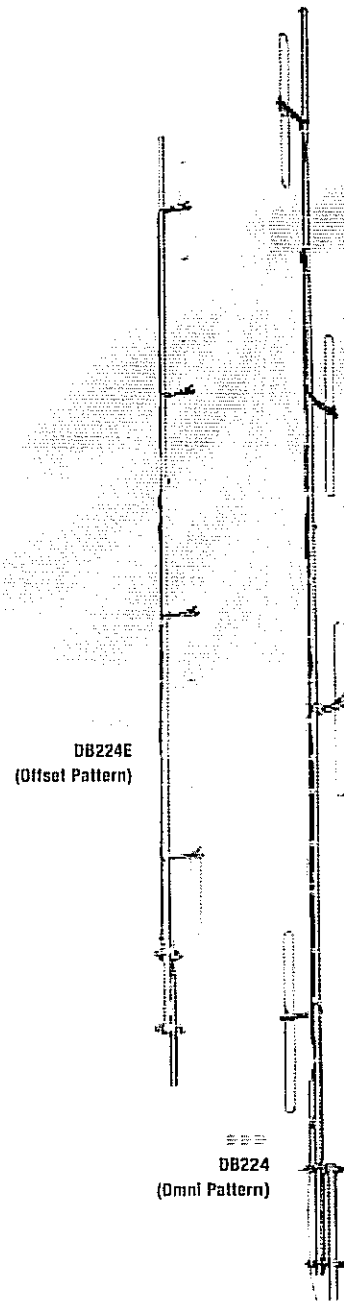

## ORDERING INFORMATION

See model number table for correct frequency and type. DB365-OS Mounting Clamps are included. For side mounting order DB5001 Side Mount Kit. For Stabilizer Kit, order 12088 (four required). For shortened mast, order DB224X. Order jumper cable separately.

# Exposed Dipole Quasi-Omni Antenna

## 138 - 174 MHz & 220 - 285 MHz / 6 or 9 dBd Gain

138 - 174 MHz

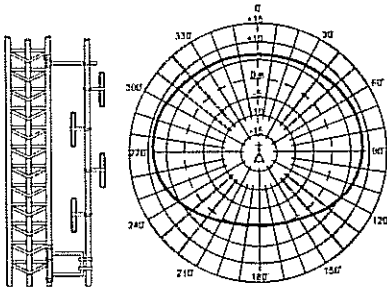
**DB224**

DB224 (omni) mounted on side of tower.

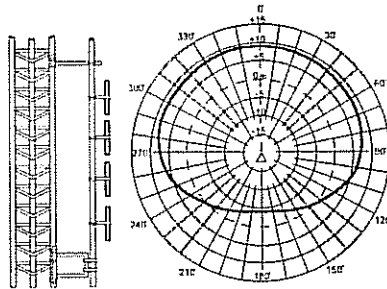

DB224E, elements pointed away from the tower.

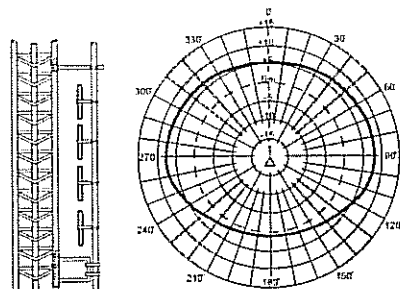

DB224E, elements pointed toward the tower.

**SIDE MOUNTING**

The patterns indicate the typical pattern shape of the antenna side mounted on a tower with an 18° to 24° (457.2 to 609.6 mm) face, using the DB5001 Side Mount Kit.

The DB5001 Side Mount Kit positions the antenna approximately 18" from the tower and consists of an upper sway brace, lower bracket (both galvanized) and the necessary hardware for attaching the bracket to round tower members up to 3" OD, or angular members up to 2" on a side. Other size clamps can be supplied on special order.

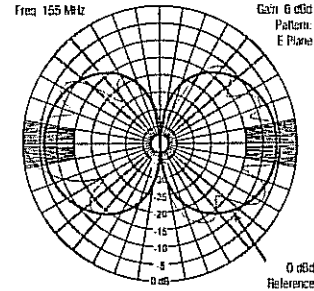
**DB224 Vertical Pattern**

**ELECTRICAL DATA**

Frequency Ranges* - MHz	See Model Table	
Bandwidth (150-174 MHz) - MHz	10	
VSWR	1.5 to 1 or less	
Nominal Impedance - ohms	50	
Gain (over half-wave dipole) - dBd	Omni Pattern	Offset Pattern
	6.0	9.0
Maximum Power Input - watts	500	
Vertical Beamwidth (half power points)	16°	
Decoupling Between Antennas (split models) - dB	35 minimum	
Lightning Protection	Direct ground	
Standard Termination	Captive Type N-Male attached to end of flexible lead.	

\* Special frequencies are available; contact factory for details.

**MECHANICAL DATA**

Mast - Upper (aluminum) - in. (mm)	1.75 (44.45) OD with 0.062 to 0.125 (1.57 to 3.18) wall	
Mast - Lower (aluminum) - in. (mm)	2 (50.8) OD with 0.125 to 0.187 (3.18 to 4.75) wall	
Radiating Elements (aluminum) - in. (mm)	0.5 (12.7) OD with 0.058 (1.47) wall	
Maximum Exposed Area (flat plate equivalent) - ft² (m²)	3.15 (0.292)	
Lateral Thrust at 100 mph (161 km/hr) - lbf (N)	126 (560.5)	
Wind Rating:*	Top Mounted	Side Mounted
Survival w/o Ice - mph (km/hr)	80 (129)	100 (161)
Survival with 0.5" (12.7 mm) Radial Ice - mph (km/hr)	55 (89)	70 (113)
Mounting Clamps (Galv. steel)	DB365-0S	

\* Calculation of wind survivability does not include damage due to flying debris.

Circular	Offset	Dual	Dual Offset	Frequency	Overall Length - in. (mm)	Net Weight (w/clamps) - lbs. (kg)	Shipping Length - in. (mm)	Shipping Width - in. (mm)	Shipping Height - in. (mm)	Shipping Weight (w/clamps) - lbs. (kg)
DB224-FAA	DB224E-FAA			127-141	279 (7087)	38 (17.25)	149 (3784.6)	17 (431.8)	8 (203.2)	48 (21.8)
DB224-A	DB224E-A			150-160	255 (6477)	35 (15.89)	149 (3784.6)	17 (431.8)	8 (203.2)	45 (20.43)
DB224-B	DB224E-B			155-165	255 (6477)	35 (15.89)	149 (3784.6)	17 (431.8)	8 (203.2)	45 (20.43)
DB224-C	DB224E-C			164-174	255 (6477)	35 (15.89)	149 (3784.6)	17 (431.8)	8 (203.2)	45 (20.43)
DB224-E	DB224E-E			138-150	279 (7087)	38 (17.25)	149 (3784.6)	17 (431.8)	8 (203.2)	48 (21.8)
DB224-F				160-170	255 (6477)	35 (15.89)	149 (3784.6)	17 (431.8)	8 (203.2)	45 (20.43)
DB224-J				276-285	165 (4191)	27 (12.26)	100 (2540)	17 (431.8)	8 (203.2)	37 (16.8)
DB224-JJ	DB224E-JJ	DB224S-JJ	DB224ES-JJ	220-225	209.75 (5328)	35 (15.89)	121 (3073.4)	17 (431.8)	8 (203.2)	42 (19.07)
		DB224S-A	DB224ES-A	150-156	255 (6477)	36 (16.34)	149 (3784.6)	17 (431.8)	8 (203.2)	46 (20.89)
<b>Antennas with Shortened Mast for Air Shipment</b>										
DB224X-A				150-160	191.25 (4858)	38 (17.25)	124 (3150)	21 (533.4)	12 (304.8)	48 (21.8)
DB224X-B				155-165	191.25 (4858)	44 (19.98)	125 (3175)	21 (533.4)	12 (304.8)	54 (24.52)
DB224X-C				164-174	191.25 (4858)	35 (17.25)	124 (3150)	21 (533.4)	12 (304.8)	48 (21.8)
DB224X-E				138-150	191.25 (4858)	44 (19.98)	96 (2438)	17 (431.8)	17 (431.8)	54 (24.52)

## **INTERGOVERNMENTAL AGREEMENT**

THIS AGREEMENT is entered into on the date set forth below and is between Tri-State Fire Protection District of DuPage County, Illinois (“Tri-State”), an Illinois Fire Protection District, and the City of Darien of DuPage County, Illinois (“Darien”), an Illinois municipality.

### **WITNESSETH**

WHEREAS, Tri-State is an Illinois Fire Protection District charged with the protection of the City and people of Darien, Willowbrook and un-incorporated DuPage County providing emergency fire, rescue, and ambulance service communications, and

WHEREAS, Darien owns and maintains certain real property known as the Darien Elevated Radio Tower (the “Radio Tower”) located on the south east corner of I-55/Cass Ave., Darien, IL.

WHEREAS, Tri-State proposes to install certain radio equipment and associated antennas (“Public Safety Communication Equipment”) for the benefit of Tri-State’s public safety communication system users on and within the Radio Tower, which users include residents of Burr Ridge; and

WHEREAS, the parties hereto have the authority to enter into this Agreement pursuant to 65 ILCS 5/11-76.1, 70 ILCS 705/10, Article VII Section 10 of the Illinois Constitution and the Illinois Intergovernmental Cooperation Act; and

WHEREAS, it is in the best interest of Tri-State and Darien to enter into this Agreement for such shared use,

NOW THEREFORE, IN CONSIDERATION OF THE MUTAL PROMISES CONTAINED HEREIN AND OTHER GOOD AND VALUABLE CONSIDERATION, the sufficiency of which is hereby acknowledged, IT IS AGREED, as follows:

1. Darien agrees to allow Tri-State, at Tri-State’s own expense, to install and maintain its Public Safety Communication Equipment on and within the Radio Tower.
2. This Agreement shall be effective upon execution by both parties and shall be for a term of twenty (20) years. In addition, Tri-State may terminate this Agreement at any time upon thirty (30) days written notice to Darien. Upon the termination of this Agreement, Tri-State shall promptly remove any Public Safety Communication Equipment installed at the Radio Tower and will restore the Radio Tower to its original condition except for reasonable wear and tear.
3. Tri-State and its employees, agents, and subcontractors shall have 24-hours-a-day, 7-days-a-week pedestrian and vehicular access to the Radio Tower at all times during the term of this Agreement for the installation, maintenance and operation

of the Public Safety Communication Equipment. Darien agrees to provide to Tri-State such codes, keys and other instruments necessary for such access at cost to Tri-State.

4. Tri-State agrees that it will be solely responsible to adequately maintain its Public Safety Communication Equipment at the Radio Tower. Tri-State further agrees that it will not use the Radio Tower in a manner that will interfere with Darien's use of the Radio Tower.
5. Tri-State at its own expense agrees to make the Darien Radio Tower suitable by supplying telephone lines to interconnect these locations to its radio networks and the Public Safety Communication Equipment. Darien agrees to allow Tri-State to install sufficient electrical power facilities for this equipment at the site at the sole cost of Tri-State. Tri-State will be responsible for the electrical usage charges for the antenna for the duration of this contract.
6. Darien agrees to exercise reasonable care to keep Tri-State's Public Safety Communication Equipment secure and undamaged. Darien, its tenants, its subcontractors, or any of its officers, agents, or employees ("Indemnites"), shall not be responsible for any loss, expenses, and damages to property, or injury to persons ("Loss") which may arise or be incident to the use and occupation of the Radio Tower, unless the Loss is related to the willful misconduct or gross negligence of the Indemnites. In addition, Tri-State shall indemnify Darien against any Losses, unless the Loss is related to the willful misconduct or gross negligence of the Indemnites. Darien agrees to notify Tri-State by telephone (630 323-6445) should there be a planned need to remove the Public Safety Communication Equipment, or should power or telephone service need to be disconnected in order to maintain the Radio Tower. Any permanent or temporary relocation of Tri-State's Public Safety Communication Equipment required by Darien shall be performed by Tri-State at its sole expense.
7. **INTERFERENCE.**
  - (a) Where there are existing radio frequency user(s) on the Property, the Landlord will provide Tenant with a list of all existing radio frequency user(s) on the Property to allow Tenant to evaluate the potential for interference. Tenant warrants that its use of the Premises will not interfere with existing radio frequency user(s) on the Property so disclosed by Landlord, as long as the existing radio frequency user(s) operate and continue to operate within their respective frequencies and in accordance with all applicable laws and regulations. Tenant further warrants that it will operate, keep and maintain the Communication Facility at all times in compliance with applicable governmental approvals and requirements to prevent material interference with other authorized radio frequency users of the Property. Tenant further agrees to cooperate with other authorized users of the Property to identify and eliminate interference problems, and Tenant agrees to cooperate with Landlord and such other tenant(s) and/or licensee(s) to resolve any disputes over radio frequency interference.
  - (b) Landlord will not grant, after the date of this Agreement, a lease, license or any other right to any third party for use of the Property, if such use may materially adversely affect or interfere with the Communication Facility, the operations of Tenant or the rights

of Tenant under this Agreement. Landlord will notify Tenant by telephone prior to granting any third party the right to install and operate communications equipment on the Property.

(c) Landlord will not use, nor will Landlord permit its employees, tenants, licensees, invitees or agents to use, any portion of the Property in any way that materially interferes with the Communication Facility, the operations of Tenant or the rights of Tenant under this Agreement. Landlord will cause such interference to cease within twenty-four (24) hours after receipt of notice of interference from Tenant. In the event any such interference does not cease within the aforementioned cure period then the parties acknowledge that Tenant will suffer irreparable injury, and therefore, Tenant will have the right, in addition to any other rights that it may have at law or in equity, for Landlord's breach of this Agreement, to elect to enjoin such interference or to terminate this Agreement upon notice to Landlord.

8. Any contractor employed by Tri-State to do work at the Radio Tower shall be properly insured and responsible for their work or any damages incurred, and shall provide Tri-State with a certificate of insurance prior to performing any work on the Radio Tower. Tri-State agrees to indemnify and hold Darien harmless from any loss, cost, or expense (including attorney fees) arising out of or related to Tri-State's installation, maintenance, or removal of Tri-State's Public Safety Communication Equipment on the Radio Tower, unless such loss, cost, or expense is related to the willful misconduct or gross negligence of Darien, its tenants, licensees, employees, invitees or agents.
9. Darien covenants and warrants to Tri-State that (i) Darien has full right, power and authority to execute this Agreement; (ii) it has good and unencumbered title to the Radio Tower free and clear of any liens or mortgages, except those disclosed to Tri-State and which will not interfere with Tri-State's rights to or use of the Radio Tower; and (iii) execution and performance of this Agreement will not violate any laws, ordinances, covenants, or the provisions of any mortgage, lease, or other agreement binding on Darien. Darien covenants that at all times during the term of this Agreement, Tri-State's quiet enjoyment of the Radio Tower or any part thereof shall not be disturbed as long as Tri-State is not in default beyond any applicable grace or cure period.
10. The tenant may not assign, sell, lease or transfer any part of this agreement, the equipment, or space to a third party.
11. The City of Darien reserves the right to perform maintenance on the tower, both structural and cosmetic. The City shall provide Tri-State sixty day notification of the intended work and the opportunity to temporarily relocate the antennas. Tri-State must relocate the antennas if required by the maintenance work. The City of Darien may terminate this contract at any time if the City of Darien chooses to demolish or cease operations at the tower.
12. This Agreement shall be deemed dated and become effective on the date the last of the parties execute the Agreement as set forth below.



The City of Darien

By \_\_\_\_\_

Dated: \_\_\_\_\_

Attest: \_\_\_\_\_

Tri-State

By: \_\_\_\_\_

Dated: \_\_\_\_\_

Attest: \_\_\_\_\_