

**AGENDA**  
**Municipal Services Committee**  
**August 24, 2015**  
**6:30 P.M. – Council Chambers**

- 1. Call to Order & Roll Call**
- 2. Establishment of Quorum**
- 3. New Business**
  - a. 709 Plainfield Road, Our Lady of Peace:** seeks approval of variations from the Sign Code: (1) to increase the permitted sign area for a religious institution from 32 to 40 square feet, Sign Code Section 4-3-8(D) and (2) to permit an electronic message board sign, Sign Code Section 4-3-10(A)
  - b. 1033-35 S. Frontage Road, Central Ave. Ventures, LLC:** Petitioner seeks approval of a text amendment, special uses and variations from the Zoning Ordinance and Sign Code related to repairing, servicing of trucks, trailers including, but not limited to transport refrigeration, standby vehicle generators, cellular communications, maintenance, body shop and engine rebuilding
  - c. Resolution –** To enter into a contract agreement with Concrete Floor Finish for the Public Works Facility Garage in the amount of \$38,500.00
  - d. Resolution –** To have the Mayor execute a contract with Alliance Contractors Inc in an amount not to exceed \$120,545.00 which includes \$10,000.00 contingency for unforeseen conditions requiring attention, for the Reconstruction of Carlisle Court Storm Water Drainage Infrastructure Reconstruction Project located within the 8700 block of Carlisle Court
  - e. Resolutions –** Approval of Illinois Department of Transportation Resolutions authorizing expenditure adjustments to balance with the Illinois Department of Transportation Motor Fuel Tax (MFT) Audit Reviews
  - f. Resolution –** To authorize additional funding in the amount of \$30,000.00 for the purpose of sharing costs for construction items associated with the street lighting project within limited locations of the 75<sup>th</sup> Street Corridor and the Cass Avenue Corridor
  - g. Minutes – May 26, 2015 Municipal Services Committee**  
– June 22, 2015 Municipal Services Committee

- 4. Director's Report**
- 5. Next scheduled meeting – Monday, September 28, 2015**
- 6. Adjournment**

**AGENDA MEMO**  
**MUNICIPAL SERVICES COMMITTEE**  
**MEETING DATE: August 24, 2015**

**Issue Statement**

**PZC 2015-11: Our Lady of Peace, 709 Plainfield Road:** Petitioner seeks approval of variations from the Sign Code:

1. To increase the permitted sign area for a religious institution from 32 to 40 square feet, Sign Code Section 4-3-8(D).
2. To permit an electronic message board sign, Sign Code Section 4-3-10 (A).

**General Information**

Petitioner/Owner: Our Lady of Peace  
709 Plainfield Road  
Darien, IL 60561

Property Location: 709 Plainfield Road

PIN: 09-27-207-024

Existing Zoning: R-2 Single-Family Residence

Existing Land Use: Religious institution

Comprehensive Plan Update: Institutional

**Surrounding Zoning and Land Use:**

North: R-1 Single-Family Residence: single-family homes, Park District maintenance facility.

East: R-3 Multi-Family Residence: multi-family dwellings

South: R-3 Multi-Family Residence: multi-family dwellings

West: B-1 Neighborhood Convenience Shopping: retail shopping center

Size of Property: 6.31 acres

Floodplain: None.

Natural Features: None.

Transportation: Property has frontage and access onto Plainfield road and 75<sup>th</sup> Street.

**Documents Submitted**

This report is based on the following information submitted to the Community Development Department by the Petitioner:

1. Sign Drawing, 1 sheet.
2. Signage Exhibit, 1 sheet, prepared by Kimley-Horn.
3. Plat of Survey, 1 sheet, prepared by Hoeffler-Butler Engineering, Inc., dated June 28, 2007.

### **Planning Overview/Discussion**

Our Lady of Peace is in the process of reconstructing their parking lot, including relocating driveway entrances, incorporating landscape islands and new parking lot lighting. As part of those improvements, the church proposes installing a new sign along Plainfield Road.

The Sign Code exempts ground signs for religious institutions from a permit as long as the sign complies with the Sign Code. Such signs are limited to 32 square feet in area.

The proposed sign is 40 square feet, with an electronic message board. Electronic message board signs are not permitted.

The sign height and location comply. The Sign Code requires landscaping at the base of the sign, extending 4 feet out from the base, to be verified at final inspection.

To be consistent with previous approvals, staff offers the following conditions:

1. Messages will be held for 3-10 seconds.
2. Messages will change all at once.
3. Messages may display multiple colors.
4. Illumination will maintain a constant light intensity or brightness.
5. Illumination brightness will comply with the Sign Code, to be verified at time of sign permit issuance.

Per Section 4-3-18 of the Sign Code, the following shall be considered:

1. The available locations for adequate signage on the property.
2. The effect of the proposed sign on pedestrian and motor traffic.
3. The cost to the applicant in complying with the Sign Code as opposed to the detriment, if any, to the public from granting of the variation.
4. If undue hardships and practical difficulties result in complying with the Sign Code and if these hardships are a result of previous actions of the applicant.
5. The general intent of the Sign Code.

Section 4-3-2 of the Sign Code provides the general intent of the Sign Code:

This sign code is adopted for the following purposes:

1. To promote and protect the public health, safety, comfort, morals, convenience and general welfare of the residents of the City.
2. To enhance the physical appearance of the City by preserving the scenic and natural beauty of the area.
3. To promote the safety and recreational value of public travel.

4. To protect the public investment in streets and highways by reducing sign or advertising distractions that may increase traffic accidents.
5. To ensure compatibility of signs with surrounding land uses.
6. To enhance the economy of the City by promoting the reasonable, orderly and effective display of outdoor advertising.
7. To protect the pedestrians and motorists within the City from damage or injury caused by distractions, obstructions and hazards created by a proliferation of off-site advertising signs.
8. To prevent the proliferation of off-site advertising signs which distract from the development of the City in an aesthetically pleasing manner.
9. To preserve the character of the City which is a single-family residential community by assuring the compatibility of signs with the surrounding land uses.

### **Staff Findings/Recommendations**

Staff finds the proposed sign an improvement over the existing sign, which includes a manual changeable copy message board. The proposed variation will not affect pedestrian and motor traffic and meets the general intent of the Sign Code by enhancing the economy of the City by promoting reasonable, orderly and effective display of signage.

Staff recommends the Commission make the following recommendation to approve the variation petition subject to conditions:

**Based upon the submitted petition and the information presented, the request associated with PZC 2015-11 is in conformance with the standards of the Darien City Code and, therefore, I move the Planning and Zoning Commission recommend approval of the petition subject to the following conditions:**

1. Messages will be held for 3-10 seconds.
2. Messages will change all at once.
3. Messages may display multiple colors.
4. Illumination will maintain a constant light intensity or brightness.
5. Illumination brightness will comply with the Sign Code, to be verified at time of permit issuance.

### **Planning and Zoning Commission Review – August 5, 2015**

The Planning and Zoning Commission considered this matter on August 5, 2015. The following members were present: Beverly Meyer – Chairperson, Andrew Kelly, Ronald Kiefer, John Laratta, John Lind, Louis Mallers, Raymond Mielkus, Pauline Oberland, Kenneth Ritzert, Michael Griffith – Senior Planner and Elizabeth Lahey – Secretary.

Michael Griffith, Senior Planner, reviewed the agenda memo. He noted the recommended conditions of approval for the electronic message board.

Andy Heinen, Kimley Horn and Associates, described the proposed sign. He stated they did not object to staff's recommended conditions of approval for the electronic message board. He noted the existing sign is 48 square feet and the proposed sign is 40 square feet. He stated there will be landscaping around the sign base. He noted there are commercial signs on the same side of Plainfield Road with residential across the street, similar to Chuck's Café on Cass Avenue, noting they also have an electronic message board sign.

Commissioner Kelly asked if the new sign would be brighter.

Mr. Heinen stated yes, but it would comply with the City's Sign Code.

No one from the public offered comments.

Commissioner's Laratta, Kiefer and Oberland stated they found the proposed sign to be acceptable.

**Without further discussion, Commissioner Laratta made the following motion seconded by Commissioner Kiefer:**

**Based upon the submitted petition and the information presented, the request associated with PZC 2015-11 is in conformance with the standards of the Darien City Code and, therefore, I move the Planning and Zoning Commission recommend approval of the petition subject to the following conditions:**

- 1. Messages will be held for 3-10 seconds.**
- 2. Messages will change all at once.**
- 3. Messages may display multiple colors.**
- 4. Illumination will maintain a constant light intensity or brightness.**
- 5. Illumination brightness will comply with the Sign Code, to be verified at time of permit issuance.**

**Upon a roll call vote, THE MOTION CARRIED by a vote of 9-0.**

### **Municipal Services Committee – August 24, 2015**

Based on the Planning and Zoning Commission's recommendation, staff recommends the Committee make the following recommendation approving the variation:

**Based upon the submitted petition and the information presented, the request associated with PZC 2015-11 is in conformance with the standards of the Darien City Code and, therefore, I move the Municipal Services Committee recommend approval of the petition subject to the following conditions:**

1. **Messages will be held for 3-10 seconds.**
2. **Messages will change all at once.**
3. **Messages may display multiple colors.**
4. **Illumination will maintain a constant light intensity or brightness.**
5. **Illumination brightness will comply with the Sign Code, to be verified at time of permit issuance.**

**Decision Mode**

Planning and Zoning Commission: August 5, 2015

Municipal Services Committee: August 24, 2015

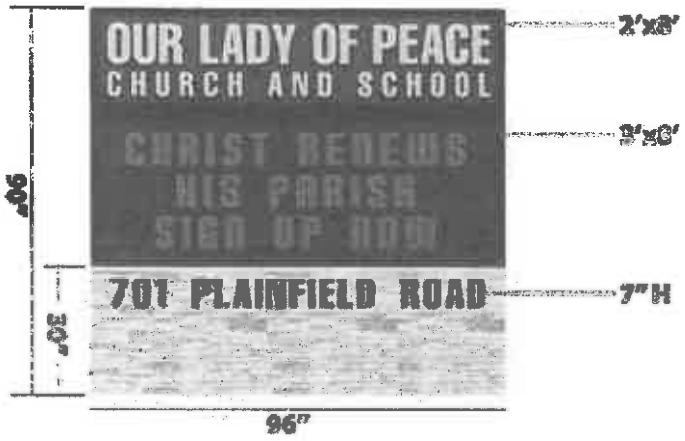



PLAINFIELD ROAD

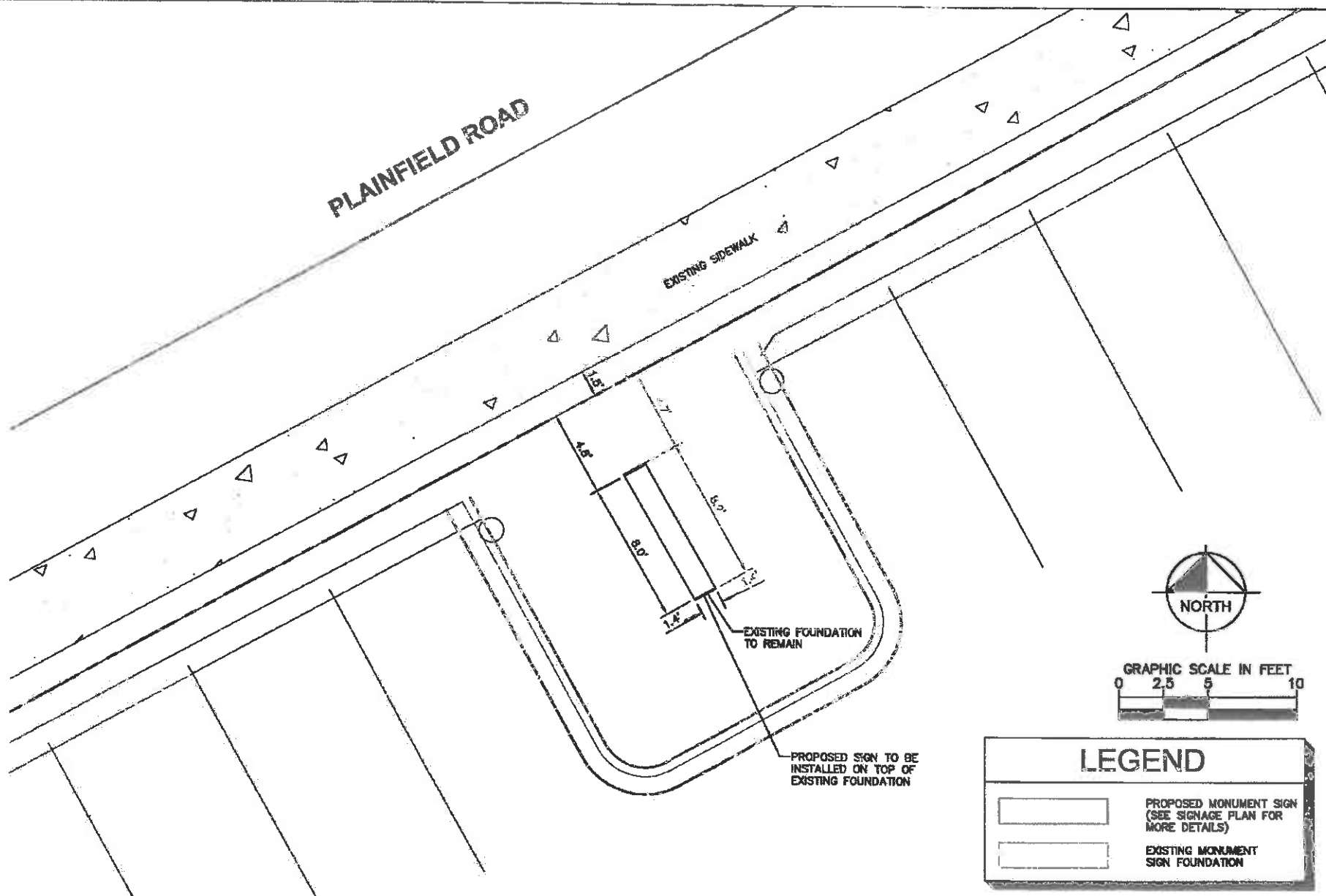

EXISTING SIDEWALK

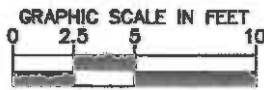

EXISTING FOUNDATION TO REMAIN

PROPOSED SIGN TO BE INSTALLED ON TOP OF EXISTING FOUNDATION



LEGEND	
	PROPOSED MONUMENT SIGN (SEE SIGNAGE PLAN FOR MORE DETAILS)
	EXISTING MONUMENT SIGN FOUNDATION

Kimley»Horn

© 2015 KIMLEY-HORN AND ASSOCIATES, INC.  
1001 WARRENVILLE ROAD, SUITE 300, LITTLE LAKE, ILL. 60032  
PHONE: 630-467-8500 WWW.KIMLEY-HORN.COM

UPDATED SIGNAGE EXHIBIT

701-709 PLAINFIELD ROAD  
DARIEN, IL

SHEET NUMBER  
EX.

# PLAN OF SURVEY

THE EAST 8 ACRES OF THAT PART OF THE WEST HALF OF THE NORTHEAST 1/4 SECTION 27 TOWNSHIP 38 NORTH, RANGE 11 EAST OF THE THIRD PRINCIPAL MERIDIAN, LYING SOUTH OF THE CENTER OF PLAINFIELD ROAD AND WEST OF A LINE THAT IS PARALLEL TO AND 492 FEET WEST OF THE EAST LINE OF THE WEST HALF OF THE NORTHEAST QUARTER OF SAID SECTION 27 (EXCEPT THE SOUTH 100 FEET THEREOF TO BE CONVEYED FOR HIGHWAY PURPOSES), IN DUPAGE COUNTY, ILLINOIS.

EXCEPTING FROM THE ABOVE PARCEL OF LAND THE FOLLOWING; THE NORTHWESTERLY 40.00 FEET (MEASURED AT RIGHT ANGLES TO THE CENTERLINE OF PLAINFIELD ROAD) OF THAT PART OF THE WEST 492.00 FEET OF THE EAST 984.00 (EXCEPT THE SOUTH 100.00 FEET THEREOF OF THE WEST HALF OF THE NORTHEAST QUARTER OF SECTION 27, TOWNSHIP 38 NORTH, RANGE 11, EAST OF THE THIRD PRINCIPAL MERIDIAN, LYING SOUTHEASTERLY OF THE CENTERLINE OF PLAINFIELD ROAD, EXCEPTING FROM SAID NORTHWESTERLY 40.00 FEET THE NORTHWESTERLY 33.00 FEET THEREOF, FALLING WITHIN THE EXISTING ROADWAY OF PLAINFIELD ROAD, IN DUPAGE COUNTY, ILLINOIS.

Sign location:

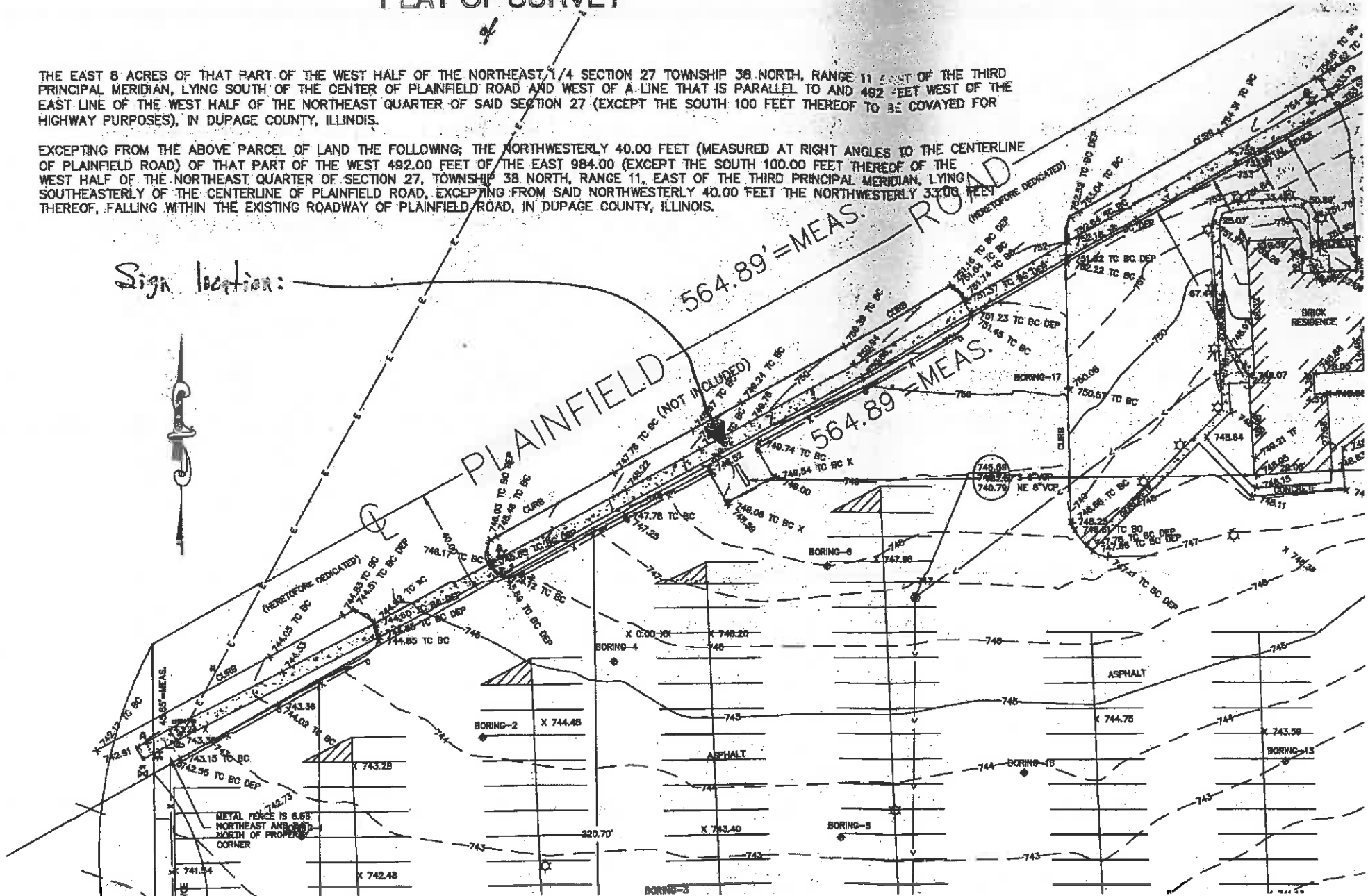

**AGENDA MEMO**  
**MUNICIPAL SERVICES COMMITTEE**  
**MEETING DATE: August 24, 2015**

**Issue Statement**

**PZC 2015-08: Central Ave. Ventures, LLC, 1033-35 S. Frontage Road:** Petitioner seeks approval of the following:

1. Text Amendment: To permit retail sales within the I-1 General Industrial zoning district, Zoning Ordinance Section 5A-9-4-3
2. Special Use: To permit a garage for storage, repair and servicing of motor vehicles, including body repair, painting and engine rebuilding within the I-1 General Industrial zoning district, Zoning Ordinance Section 5A-9-4-4.
3. Special Use: To permit a freight terminal within the I-1 General Industrial zoning district, Zoning Ordinance Section 5A-9-4-4.
4. Special Use: To permit outdoor storage within the I-1 General Industrial zoning district, Zoning Ordinance Section 5A-9-4-4.
5. Variation: To reduce the required parking lot setback from 30 feet to 10 feet, 17 feet and 5 feet along rear, east and west side yards respectively, Zoning Ordinance Section 5A-9-4-7.
6. Variation: To eliminate the required hard surface for parking lot and to permit the existing stone aggregate on the south portion of the site, Zoning Ordinance Section 5A-11-2-1(F).
7. Variation: To increase the total permitted impervious surface from 75% to 81.4%, Zoning Ordinance Section 5A-9-4-8.
8. Variation: To permit a third driveway off of S. Frontage Road, said third driveway being less than the required 200 feet apart, Zoning Ordinance Section 5A-11-3(B).
9. Variation: To permit a loading dock within the front where it is otherwise required to be within an interior side yard or rear yard, Zoning Ordinance Section 5A-11-4-1(C)
10. Variation: To eliminate the required screening fence along the rear, east and west side lot lines, Zoning Ordinance Section 5A-9-4-7(B).
11. Variation: To permit a permit a pole mounted, free-standing sign, Sign Code Section 4-3-7(B).
12. Variation: To increase the permitted sign height from 6 feet to 57 feet, Sign Code Section 4-3-10(C).
13. Variation: To increase the permitted sign area from 60 square feet to 144 square feet, Sign Code Section 4-3-10(C).3
14. Variation: To permit a pole sign within 20 feet of a driveway, Sign Code Section 4-3-7(E).
15. Variation: To eliminate the required perimeter yard landscaping along the south and east lot lines, Zoning Ordinance Section 5A-10-5

**General Information**

Petitioner: Central Ave. Ventures, LLC  
Doug Calay  
700 Enterprise Street  
Aurora, IL 60504

Property Owner: GD Darien LLC  
1035 S. Frontage Road  
Darien, IL 60561

Property Location: 1033-35 S. Frontage Road

PINs: 09-34-303-025; 09-34-303-027; 09-34-303-029

Existing Zoning: I-1 General Industrial

Existing Land Use: Vacant

Proposed Land Use: Garage for storage, repair and servicing of motor vehicles, including body repair, painting and engine rebuilding (principal use)

Comprehensive Plan Update: Industry

**Surrounding Zoning and Land Use:**

North: OR&I Office, Research and Light Industry: I-55, vacant (proposed hotel).  
South: R-1 Single-Family Residence District (DuPage County) – forest preserve.  
East: R-2 Single-Family Residence District (DuPage County) – single-family home.  
West: I-1 General Industrial District: Municipal Services Facility.

Size of Property: 10 acres

Floodplain: Floodplain extends onto the east portion of the property.

Natural Features: None.

Transportation: Frontage and access onto S. Frontage Road

History: The property has been vacant for several years. Previously, the property was a drop yard for storing semi-trailers.

**Documents Submitted**

This report is based on the following information submitted to the Community Development Department by the Petitioner:

1. Variation Request, Exhibit A, prepared by Central Ave. Venture, LLC.
2. Narrative Describing the Daily Operation, Exhibit B, prepared by Central Ave Venture, LLC.
3. Email from Doug Calay, Director of Facilities, IAE, dated August 17, 2015.
4. Letter from SPACECO Inc., dated August 12, 2015.

5. Noise Survey Report, prepared by Optimum Safety Management, dated August 14, 2015.
6. Traffic Study, prepared by KLOA, dated August 17, 2015.
7. Site Plan, 1 sheet, prepared by Partners in Design, dated August 14, 2015.
8. Building Elevations (IAE building), 1 sheet, prepared by Partners in Design, dated August 14, 2015.
9. Building Elevations (modular building), 1 sheet, prepared by Innovative Modular Solutions, dated August 13, 2015.
10. Sign Drawing, 1 sheet, prepared by Parvin-Clauss, dated August 14, 2015.
11. Landscape Plan, 3 sheets, prepared by Wingren Landscape, dated June 9, 2015.
12. Photometric Plan, 1 sheet, dated June 29, 2015.
13. Engineering Plan, 5 sheets, prepared by SPACECO, Inc., dated June 25, 2015.

### **Planning Overview/Discussion**

The subject property is directly east of the City's Municipal Services Facility on S. Frontage Road, east of Cass Avenue. The property has been vacant for several years. Previously, it was used as a drop yard for semi-trailers.

Currently, on the property, there is a building at the north end of the property with the bulk of the property covered with stone (aggregate) where trailers were stored.

The proposed site plan a new building housing the shop, warehouse, and showroom/office support and a smaller office building. The bulk of the site will be stone (aggregate) for storing semi-trailers.

The proposed uses are summarized below:

- a. Garage for repairing, servicing trucks, trailers related to transport refrigeration, standby vehicle generators, cellular communications equipment, maintenance, body repair, painting and engine building. *Special use.*
- b. Retail sales of related equipment and parts. *Text amendment*
- c. Warehouse for distribution of related equipment and parts.
- d. Drop yard for trailers.
- e. Limited freight terminal. *Special use.*
- f. Cartage and express facility.
- g. Accessory outdoor storage. *Special use.*
- h. Office functions related to above uses.

The proposed site plan essentially maintains the current layout of the property. The variations requested primarily note existing conditions.

The landscape plan provides landscaping along the frontage of the property, meeting the required landscaping requirements. Landscape islands within the parking lot should show at least 1 shade tree and 16 shrubs. Adjacent properties are either Forest Preserve or the City's Municipal Services Facility. Therefore, staff does not find the need to require landscaping to the south of

the building given the uses on adjacent properties.

The building elevation drawing shows the following exterior predominately precast concrete.

The petitioner needs to provide signage details, specifically, the pole sign, since they are seeking variations related to sign height and area.

A small area of floodplain extends onto the east side of the property. The petitioner is working with the U.S. Army Core of Engineers and DuPage County to confirm jurisdiction over the wetlands. Assuming DuPage County has jurisdiction, DuPage County is required to certify the plans comply with floodplain/wetland regulations before the City can issue a permit for construction.

The City Engineer reviewed the plans. Stormwater water management, detention, is an issue yet to be resolved. Staff hopes to have an update on this matter at the meeting, see letter from Dan Lynch, PE, Christopher B. Burke, dated July 21, 2015.

### **Staff Findings/Recommendations**

Staff will provide a recommendation at the meeting.

### **Planning and Zoning Commission Review – August 5, 2015**

The Planning and Zoning Commission considered this matter on August 5, 2015. The following members were present: Beverly Meyer – Chairperson, Andrew Kelly, Ronald Kiefer, John Laratta, John Lind, Louis Mallers, Raymond Mielkus, Pauline Oberland, Kenneth Ritzert, Michael Griffith – Senior Planner and Elizabeth Lahey – Secretary.

Michael Griffith, Senior Planner, reviewed the agenda memo. He summarized the proposed uses and variations being requested, noting most of the variations related to existing conditions. He stated the proposed development plan is essentially the same current layout of the property.

He noted summarized the letter of objection dated August 5, 2015, from the DuPage County Forest Preserve District and noted a petition was submitted with two names on it objecting to the proposed use.

Bill Fritz, IAE, President/COO, described the company and proposed Darien facility. He stated the Darien facility will handle their transport refrigeration and distribution activities. He stated they sell and service Thermo King transport refrigeration units. He stated they plan to sell related parts. He stated this facility will have about 50 employees. He stated they value a clean, orderly operation both for their employees and customer benefit. He stated this site is ideal due to the frontage and access to I-55.

He stated they have organized their check-in procedures and site plan to make sure trucks are not sitting on S. Frontage road. He described where trucks enter/leave the site, noting the driveway

locations.

There was a question as to who had jurisdiction on the roadway.

He stated they plan to sub-lease a portion of their property for a trailer drop yard.

He introduced the IAE team:

Doug Caley, Director of Facilities

Robert Stearns, Manager, Central Avenue facility.

Paul Cohan, Principle Construction Corp., construction manager.

Chairperson Meyer asked about hours of operation.

Mr. Fritz stated:           Monday – Friday: 7am – 11:30pm  
                                      Saturday: 7am – 3:30pm.

He stated there will be some 24-hour activity to handle emergencies where they send a mobile unit to service a stalled truck or piece of equipment.

Commissioner Laratta asked who is responsible for the operation and maintaining the leased area.

Mr. Fritz stated they are responsible for maintaining the property.

Commissioner Kiefer asked about fuel storage.

Mr. Stearns stated they store off-road diesel not motor fuel diesel.

Commissioner Mallers stated it seemed this was essentially the same use as before.

There was a question about trucks staying overnight with engines running. Mr. Stearns stated typically trucks are not parked overnight. He stated there may be a few CR England trucks parked overnight but most likely they will run their generators to heat/cool the truck cabin and not run the engines.

There was a question about security. Mr. Caley stated the entire site is surrounded by a fence and there is closed circuit TV.

Commissioners Lind and Oberland stated the modular building, the leased out space, should tie into the main building. Commissioner Oberland stated there are inexpensive ways to make the buildings coordinate.

Mr. Cohan stated they could accommodate that concern.

Commissioner Lind asked if the loading dock could be moved to the east side of building.

Mr. Cohan stated the site is constrained by wetlands and that they want to maximize the bulk of the property for trailers. It was noted they receive 3 shipments per week on average. Mr. Lind was fine with that response.

Commissioner Lind asked if screening could be considered along the east side of the property to better screen property from the Frontage Road. Mr. Cohan stated there is landscaping and screening along the frontage of the property.

Commissioner Ritzert asked about noise from repairs.

Mr. Stearns stated equipment repairs occur inside the building, with the service bay doors on the backside of the building. It was noted the noise from I-55 would likely be louder than their operations.

Commissioner Mielkus asked about paint spraying.

Mr. Caley stated there is not painting.

Doug Echner, Timber Lakes, stated his concern about underground fuel storage and with increased traffic on Frontage Road also used by bikers.

Joe Kremper, Lorraine, stated he is opposed to use, noting property is next to the Forest Preserve. Stated his concern with trucks managing the curved roads, hazardous materials, noise, lighting stating the chain link fence is ugly, opposed to 24-hour operation and light.

Lorraine Leong, Timber Lakes, stated her concern with increased traffic and pollution, stated the variations are contrary to the City's Code.

Linda Painter, Timber Lakes, and Forest Preserve Commissioner, stated they are requesting too many variations. She stated the setback along Forest Preserve property should meet requirements, three entrances of Frontage Road is dangerous. She stated should go east as there is a weight restriction on those roads. She stated the pole sign and lighting will be offensive. She stated there should be more landscaping. She stated the outdoor storage will be offensive, further concerned with run-off and noise.

Ms. Painter read the letter dated August 5, 2015, from the Forest Preserve.

Steve Delurgio, Timber Lake, stated the property should be used for parking only. He stated is objection to 24-hour operation, concerned with light pollution, stated use changes character of the property, wants to see a solid fence around the site.



William VanDam, Timber Lake, stone surface should be a hard surface instead to eliminate dust, concerned with no perimeter landscaping.

Richard Rons, 89<sup>th</sup> Place, land should be residential instead of industrial, stating homes would be a better use.

William Mars, Timber Lake, stated his concerns about noise and light.

Mike Webster, Timber Lake, stated school buses use S. Frontage Road.

Bill Fritz responded to resident comments, noted they do not tow stall trucks/trailers to their location they instead send out a mobile unit to service the equipment. He stated it is not typical for trucks to be parked on the property over night with engines running, they would use their on-truck generators instead.

The Commission expressed concern about S. Frontage Road being able to handle truck traffic, with wetland and stormwater management comments not yet addressed, the modular building should tie into the main building aesthetically.

There was a motion to recommend denial based on not having a traffic study (motion made by Commissioner Kelly, seconded by Commissioner Mallers). However, the motion failed by a 2-7 vote. Several Commission members stated they were not ready to make a decision either way and the petitioner should be given an opportunity to return with additional information.

**Without further discussion, Commissioner Ritzert made a motion to continue the item to give the petitioner time to address comments and concerns raised by residents and the Commission, including a traffic study, wetland and roadway jurisdiction, Commissioner Kiefer seconded the motion.**

**Upon a roll call vote, THE MOTION CARRIED by a vote of 9-0.**

### **Planning and Zoning Commission Review – August 19, 2015**

The petitioner provided additional information based on comments at the August 5, 2015, Planning and Zoning Commission meeting, including a traffic study, drawings of the modular building and pole sign.

Variation approval criteria:

1. Whether the general character of the property will be adversely altered.
2. Whether the overall value of the property will be improved and there will not be any potential adverse effects on the neighboring properties.
3. Whether the alleged need for the variation has been created by any person presently having a proprietary interest in the premises.

4. Whether the proposed variation will impair an adequate supply of light and air in adjacent property, substantially increase congestion in the public streets, increase the danger of fire or endanger the public safety.
5. Whether the proposed variation will adversely alter the essential character of the neighborhood.

Special Use approval criteria:

1. That the special use is deemed necessary for the public convenience at the location specified.
2. That the establishment, maintenance, or operation of the special use will not be detrimental to, or endanger the public health, safety, or general welfare.
3. That the special use will not be injurious to the use and enjoyment of other property in the immediate vicinity for the purposes already permitted, nor substantially diminish and impair property values within the neighborhood.
4. That the establishment of the special use will not impede the normal and orderly development and improvement of the surrounding property for uses permitted in the district.
5. That the exterior architectural design, landscape treatment, and functional plan of any proposed structure will not be a variation with either the exterior architectural design, landscape treatment, and functional plan of the structures already constructed or in the course of construction in the immediate neighborhood or the character of the applicable district, as to cause a substantial depreciation in the property values within the neighborhood.
6. That adequate utilities, access roads, drainage, and/or necessary facilities have been or are being provided.
7. That adequate measures have been or will be taken to provide ingress and egress so designed as to minimize traffic congestion in the public streets.
8. That the special use shall, in all other respects, conform to the applicable regulations of the district in which it is located, except as such regulations may, in each instance, be modified by the City Council pursuant to the recommendations of the planning and Zoning Commission and the Planning and Development Committee.

Sign Code variation criteria:

1. The available locations for adequate signage on the property.
2. The effect of the proposed sign on pedestrian and motor traffic.
3. The cost to the applicant in complying with the Sign Code as opposed to the detriment, if any, to the public from granting of the variation.
4. If undue hardships and practical difficulties result in complying with the Sign Code and if these hardships are a result of previous actions of the applicant.
5. The general intent of the Sign Code.

General intent of the Sign Code:

1. To promote and protect the public health, safety, comfort, morals, convenience and general welfare of the residents of the City.
2. To enhance the physical appearance of the City by preserving the scenic and natural beauty of the area.
3. To promote the safety and recreational value of public travel.
4. To protect the public investment in streets and highways by reducing sign or advertising distractions that may increase traffic accidents.
5. To ensure compatibility of signs with surrounding land uses.
6. To enhance the economy of the City by promoting the reasonable, orderly and effective display of outdoor advertising.
7. To protect the pedestrians and motorists within the City from damage or injury caused by distractions, obstructions and hazards created by a proliferation of off-site advertising signs.
8. To prevent the proliferation of off-site advertising signs which distract from the development of the City in an aesthetically pleasing manner.
9. To preserve the character of the City which is a single-family residential community by assuring the compatibility of signs with the surrounding land uses.

### **Municipal Services Committee – August 24, 2015**

Staff will update the Committee on the August 19, 2015, Planning and Zoning Commission meeting discussion/recommendation.

The list of documents submitted by the petitioner has been updated, pages 2-3 of this memo. The site plan has been revised since the initial submittal, therefore, the landscape plan, engineering plan and photometric plan reflect the previous site plan.

The most recent City Engineer review comments are noted in a letter dated August 17, 2015, updated August 19, 2015, from Dan Lynch, PE, Christopher B. Burke Engineering.

Letters and petitions of objection were submitted to the Planning and Zoning Commission at their August 5, 2015, meeting. Copies will be made available to the Committee at the meeting.

### **Decision Mode**

Planning and Zoning Commission:	August 5, 2015
Planning and Zoning Commission:	August 19, 2015
Municipal Services Committee:	August 24, 2015



**CHRISTOPHER B. BURKE ENGINEERING, LTD.**

9575 West Higgins Road Suite 600 Rosemont, Illinois 60018 TEL (847) 823-0500 FAX (847) 823-0520

August 17, 2015

**Revised August 19, 2015**

City of Darien  
1702 Plainfield Road  
Darien, IL 60561

Attention: Dan Gombac

Subject: Illinois Auto Central: 1033-1035 S. Frontage Road  
(CBBEL Project No. 950323H184)

Dear Dan:

As requested by email on August 12, 2015, we have reviewed the response to our July 21, 2015 letter as prepared by Spaceco, Inc. and dated August 12, 2015. As you know, Spaceco is an affiliate company of Christopher B. Burke Engineering, Ltd. (CBBEL). Based on the information provided on the preliminary plan, the development will not trigger a requirement to provide additional stormwater detention or water quality infrastructure, but they will be required to maintain the existing stormwater improvements on the site. This has been acknowledged, as have our other comments on the preliminary plan. The following item should be noted:

1. We understand that the City will require the applicant to extend a sanitary service to their west property line for future connection of the Public Works Building. This will likely necessitate that a portion of the sewer be public, but we will defer to DuPage County, who owns the sewer.

If you have any questions, please feel free to contact me.

Sincerely,

Daniel L. Lynch, PE, CFM  
Head, Municipal Engineering Department

**Central Ave Venture, LLC  
GD Darien LLC  
1033 – 1035 S. Frontage Rd., Darien IL 60561  
Variance / Special Use / Tax Amendment - Nature of Request**

**Exhibit 'A'**

**Variance Request:**

- 1. We are requesting a reduction of pavement setback from 30' to 10' and 17' at the south and east property lines respectively. The adjacent property to the south and east is the Waterfall Glen Forest Preserve. However, the County maps list the property as a residential use which would require a 30' pavement setback. It is our understanding that this property will remain undeveloped as a Forest Preserve. Additionally, the existing aggregate surface is as close as 5'-0" and 7'-0" to the south and east property lines respectively.**
- 2. We are requesting that the pavement setback be changed to 5' along the west property line. The existing aggregate surface is as close as 4'-0" to the west property line. The adjacent west property is currently occupied by the Village of Darien Public Works Building and would require a 20' pavement setback. In order to accommodate the required quantity of trailer, tractor stalls and maneuvering clearances a 5' pavement setback is required by the user.**
- 3. We are requesting to leave the existing stone aggregate on the south 'private' portion of the site. The majority of the south portion of the existing lot is stone aggregate. The north 'public' portion of the site, most visible from S. Frontage Rd. and used by the public, would be paved with asphalt or concrete paving. If the entire site were required to be paved, the cost along with the additional requirement for storm water detention would make the project economically infeasible.**
- 4. We are requesting that the existing non-conforming impervious site area which exceeds the total impervious site area requirement be allowed to be maintained. Due to the unique nature of the user which requires a certain amount of tractor and trailer stalls, the required pervious surface area cannot be accommodated.**
- 5. We are requesting that three driveway entrances be provided with the driveway separations indicated on our site plan. Three main entry drives are required to provide the needed vehicular flow for the users operations.**
- 6. We are requesting that the loading dock be located in the front of the building. Landscape screening will be provided to minimize the visibility of the loading dock. Due to the unique nature of the user which requires a certain amount of tractor and trailer stalls, the recessed loading dock needs to be located on the north side of the building.**
- 7. We are requesting the ability to use an 8' high chain link fence without any solid portions along the south east and west property lines. Zoning requires that a percentage of the fence be solid. Since the**

adjacent property to the south and east to the Waterfall Glen Forest Preserve, there are no adjacent users that will be affected.

8. We are requesting the ability to install a pole mounted illuminated sign which is 12' W x 12' H = 144 SF and 57' H (overall sign height). The sign will be located at the northeast corner of the property providing our client maximum visibility and business identification along the I-55 interstate corridor. The size and location of the sign proposed provides business identification allowing for a reasonable amount of reaction time to potential customers driving at high rates of speed along I-55 from the east and the west so that they can react to and exit at the next available interstate exit. The current zoning / code does not allow for a pole mounted sign on our site. Due to the specific nature of our clients operation a pole mounted sign is necessary to provide business identification along the I-55 corridor.

9. We are requesting a variance from the requirement for planting and landscape materials along the south rear yard and the east interior side yard. These areas are presently devoid of landscaping and are immediately adjacent to the Waterfall Glen Forest Preserve. There are no adjacent users that will be affected and these areas will remain as undeveloped land. Additionally, we are requesting a variance from the requirements for planting and landscape materials along the corner side yard adjacent to the west property which is currently occupied by the Village of Darien Public Works Building. Since we address a variance request in item #2 above for a pavement setback along this area, we feel that a similar variance request for planting and landscape materials in this area is a direct function of this request.

#### Special Use Request:

#1. We are requesting a special use consideration to allow for outdoor storage on-site. The outdoor storage area will be located south of the proposed building and will be enclosed on the north side with solid fencing in order to provide a visual block from the public way along S. Frontage Rd.

#2. We are requesting a special use consideration to allow for garage storage, repair and or servicing of motor vehicles, including body repair, painting and engine rebuilding. These services are integral part of our client's business model and a part of the proposed plan for this particular site.

#3. We are requesting a special use consideration to allow for a portion of our site, (private) along the south and west property lines to be used as a freight terminal. This service is a component of our client's business model and a service which they provide to their customers and is part of the proposed plan for this particular site.

#### Tax Amendment:

#1. We are requesting a tax amendment be provided to our client for retail sales in the I-1 zoning district as this is an integral part of our client's business model and part of the proposed plan for this particular site.

**Central Ave Venture, LLC  
GD Darien LLC  
1033 – 1035 S. Frontage Rd., Darien IL 60561  
"A Day in the Life"  
Narrative Describing The Daily Operation of Illinois Auto Central**

**Exhibit 'B'**

**Illinois Auto Central Thermo King (IACTK) is a factory authorized sales and service dealer for Thermo King, the world leader in transport temperature control and auxiliary power units.**

**Illinois Auto Central and Thermo King's daily operation revolves around two main components, our shop operation with warehouse and office support staff and there is also a small modular office and truck yard that we lease to our customer CR England. We adhere to a strict set of high standards in keeping our facilities clean and safe. Honesty and fair service are integral parts of who we are.**

**Illinois Auto Central Thermo King**

**The way this site plan is designed to work, is that our customers will enter our site from the frontage road and enter onto the center driveway. This center driveway leads into our check-in/inspection area. At this point we evaluate our customers' needs and direct them to a designated location for the services to be completed. Once services are completed, the driver will exit our site through the east driveway.**

**Our shop is located adjacent to our office and warehouse support staff. The shop consists of nine service bays, fuel-island, wash bay, and roughly 30 mechanics over three shifts. Within our office area, we will have a retail showroom for customers to view and purchase related parts and accessories (retail sales). This space will also include private offices, conference rooms, lunchroom, restrooms, a service and parts counter and a customer waiting lounge.**

**The warehouse is designed to receive and distribute all parts related to our sales and service operations. South of the warehouse in the exterior yard space, we have an area designated for outside storage. Here is where we will store our influx of Thermo King units and the trash dumpsters.**

**Leased CR England Space**

**CR England's tractors and trailers will enter into the west driveway for access into yard space which is segregated from IACTK's space. Here is where they park their commercial tractors and trailers to support their 24 hour drop yard. Incorporated in this area will be a modular office with personnel to support their operation.**

**From:** Doug Calay  
**Sent:** Monday, August 17, 2015 9:18 AM  
**To:** 'Dan Gombac'; 'Michael Griffith'  
**Cc:** Bill Fritz; 'Paul Cohen'  
**Subject:** RE: #2015-15: IAC Darien (Public Hearing Comments From Michael Griffith)

Dan, Mike,

See below for our updates related to these items.

Thank you,

Doug Calay  
Director of Facilities  
Illinois Auto Electric Co.  
700 Enterprise St.  
Aurora IL 60504  
630-862-3199 Office

**From:** Michael Griffith  
**Sent:** Thursday, August 06, 2015 3:08 PM  
**To:** Dan Gombac  
**Subject:** IAE, 1033-35 S. Frontage Rd

After reviewing my notes, bullet points from the PZC meeting last night:

**Commission:**

- **West building elevation to tie into main building.**
  - A preliminary rendering of the West building elevation will be submitted on Monday 8/17/2015. The façade of this West building will be aesthetically pleasing and will complement the design of the East building. The size of this building is still up for review and subject to change based upon needs.
- **Commission concerned that vehicle repair language from Zoning Ordinance is too broad, seemed to want it better defined as to what is being approved.**
  - IAC is asking for the special use "To permit a garage for storage, repair and servicing of motor vehicles, including body repair, painting and engine rebuilding within the I-1 General Industrial zoning district, Zoning Ordinance Section 5A-9-4-4."
- **Traffic study, mainly whether S. Frontage Road and intersection with Cass Ave. can accommodate semi-truck traffic.**
  - IAC is working with KLOA a traffic and transportation / engineering firm to complete a traffic evaluation study. This traffic evaluation study will be submitted to the City of Darien on Monday 8/17/2015 for review.
- **Stormwater management not resolved.**
  - This development will meet all of the applicable codes with regard to storm water management. This project will be required to meet the DuPage County Stormwater Ordinance. We have prepared preliminary plans and met with the City of Darien and DuPage



County to review the stormwater detention, wetlands, and floodplain aspects of the project. Both Darien and DuPage County have given us positive feedback regarding the preliminary plans. No variances to the stormwater, wetlands, or floodplain requirements are being requested by the petitioner.

- o August 12, 2015, SPACECO Engineers submitted a response to the City of Darien related to the review of preliminary plans performed by Christopher B. Burke Engineers on July 21, 2015 (subject: Illinois Auto Central: 1033-1035 S. Frontage Road, CBBEL Project No. 950323H1840). These letters will be submitted to the City of Darien on Monday 8/17/2015 to be included with the submittal.

- o **Dress up fence screening along front.**

- o IAC looked at various options in gates to provide the best functionality, security and screening. All gates previously were a barrier style similar to a toll booth arm. After further review, IAC has decided to install a slide gate on East exit, a slide gate at the center inspection entry/exit and a swing gate at the West entry/exit. These gates and the front fence will have limited to no opacity.

- o **Retail Sales**

- o In regards to your request, below is a summary of the annual retail sales for the years 2012 through 2014 along with what the one percent portion of the sales tax that the city of Darien would have received from these retail sales.

<u>Year</u>	<u>Retail Sales</u>	<u>1% Darien Sales tax revenue</u>
2012	\$1,603,827	\$16,038
2013	\$1,521,179	\$15,212
2014	\$2,176,076	\$21,761

**Residents (unincorporated):**

- o **Traffic. Increased traffic, traffic from semi-trucks, trucks along with bike riders, school buses and other motorists on S. Frontage Road will increase accidents. Trucks not able to make turns/curves from Cass Avenue.**
  - o IAC is working with KLOA a traffic and transportation / engineering firm to complete a traffic evaluation study. This traffic evaluation study will be submitted to the City of Darien on Monday 8/17/2015 for review.
- o **Noise from truck traffic, engines running, refrigeration units running outdoors and overnight, repair activities. (IAE testimony: CR England truckers [sub-leased area] may park their truck overnight, most likely running their generators and not engines.)**
  - o IAC is working with Optimum Safety Management who conducted a noise assessment at the property on 8/13/2015 and 8/14/2015 to support the intended development. This report will be provided to the City of Darien on Monday 8/17/2015 for review.
  - o The types of noise that will be generated at this facility include:
    - Fork Lifts, Semi-Trucks, truck and trailer mounted temperature control systems running, auxiliary power units, truck and trailer repair.
  - o IAC plans to run 3 shifts at this site:
    - Shift 1 – Start time 7:00am, end time 3:30pm
      - 65% of the service work is performed between 7:00am and 3:30pm. During this time the operations include sales and service of truck and trailer mounted temperature control systems, auxiliary power units along with truck and trailer repair. Between these hours we have service advisors, office and warehouse staff to support these functions. There will be roughly 28 employees supporting this operation during this time.

- Shift 2 – Start time 3:00pm, end time 11:30pm
    - 30% of service work will be performed between 3:30pm and 11:30am. During this time the operations include sales and service of truck and trailer mounted temperature control systems, auxiliary power units along with truck and trailer repair. Between these hours we have service advisors and limited warehouse staff to support these functions. There will be roughly 8 employees supporting this operation during this time.
  - Shift 3 – Start time 11:00pm, end time 7:30am
    - 5% of service work will be performed between 11:00am and 7:30am. During this time the operations include service of truck and trailer mounted temperature control systems and emergency call outs to provide remote service for customers off-site. No other support staff other than mechanics are on hand during this time. There will be roughly 3 employees supporting this operation during this time.
- Regarding the CR England activities, this location will be used to manage a portion of their Chicagoland fleet trucks and trailers. These trucks are day cab trucks without sleepers or generators, they are not left running when not in use. 60% of the CR England traffic observed on 8/10/2015 were trucks only without a trailer entering and exiting. Because they operate within the Chicagoland area, when their drivers have completed their shift they park their truck onsite, shut it down and leave until the next day.
- Light pollution.
  - Site lighting will comply with the local ordinance. Shields will be installed where required.
- Fuel storage, refrigerant storage, hazardous materials.
  - Any fuel storage, refrigerant storage or hazardous material storage will be handled with the appropriate permits and inspection to meet jurisdictional requirements.
  - IAC currently maintains a 15,000 gallon underground storage tank (UST) at the existing Chicago facility. IAC plans to install a similar tank at this site while following the appropriate permits and inspections to meet the jurisdictional requirements.
- 24-hour operation (IAE testimony: late night/overnight activities are mostly IAC going off-site to stalled truck for emergency repairs of refrigeration units).
  - It is IAC's intent to have a 24-hour service operation. IAC will respect all zoning requirements related to the zoning ordinance affecting this development and use.
  - IAC plans to run 3 shifts at this site:
    - Shift 1 – Start time 7:00am, end time 3:30pm
      - 65% of the service work is performed between 7:00am and 3:30pm. During this time the operations include sales and service of truck and trailer mounted temperature control systems, auxiliary power units along with truck and trailer repair. Between these hours we have service advisors, office and warehouse staff onsite to support these functions. There will be roughly 28 employees supporting this operation.
    - Shift 2 – Start time 3:00pm, end time 11:30pm
      - 30% of service work will be performed between 3:30pm and 11:30am. During this time the operations include sales and service of truck and trailer mounted temperature control systems, auxiliary power units along with truck and trailer repair. Between these hours we have service advisors and limited warehouse staff to support these functions. There will be roughly 8 employees supporting this operation.
    - Shift 3 – Start time 11:00pm, end time 7:30am
      - 5% of service work will be performed between 11:00am and 7:30am. During this time the operations include service of truck and trailer mounted temperature control systems and emergency call outs to provide remote service for customers off-site. No other support staff other than mechanics are on hand during this time. There will be roughly 3 employees supporting this operation.

- **Lack of screening along back portion of property.**
  - Our plan provides for an 8' chain link fence along the south, east and west limits of the property.
- **Opposed to use. Property should be parking only. One resident stated property should be residential use.**
  - This development is presently zoned as I-1 which is industrial. This zoning is appropriate for our proposed development.
- **Too many variations requested.**
  - We feel that the variance request items previously presented to staff are reasonable and should be considered for approval by this commission.
- **Lack of setback from Forest Preserve property. Should provide landscaping along sides and rear.**
  - We are reducing the impervious surfaces by 15% on the east and 21% on the south. Additionally, we are improving the existing surface areas at the site perimeter and placing turf grass and native ground cover.
- **Pole sign would be eyesore.**
  - A pole sign would provide visibility to IAC's customer base. There are pole signs along the I-55 corridor on industrial sites, this site is zoned I-1 and our request for a pole sign is not an unreasonable request. IAC is working with a few pole sign contractors to further develop signage requirements. A preliminary rendering of what the sign will look like will be submitted to City of Darien prior to the meeting on 8/19.
- **Trailer parking area should be hard surface to eliminate hazardous materials seeping into ground, eliminate dust.**
  - The existing aggregate surface is an existing condition which will be improved upon. The north parking lot areas and all entry / exit drives will be new asphalt paving. 50' of concrete will be added to the south of the service shop and indicated on the site plan.

Michael Griffith  
Senior Planner  
City of Darien  
630.353.8113

Please sign up for the ***DARIEN DIRECT CONNECT*** Newsletter, the best way to receive current information for the community. Just click on this link and enter your e-mail address!  
<http://www.darien.il.us/Reference-Desk/DirectConnect.aspx>



9575 W. Higgins Road, Suite 700, Rosemont, Illinois 60018  
Phone: (847) 696-4060 Fax: (847) 696-4065

August 12, 2015

Mr. Michael Griffith  
City of Darien  
1702 Plainfield Road  
Darien, IL 60561

**RE: ILLINOIS AUTO CENTRAL: 1033-1035 S. FRONTAGE ROAD  
SPACECO PROJECT NO. 8552**

Dear Mr. Griffith:

Attached please find our responses to comments in the letter from Christopher Burke Engineering dated July 21, 2015. Please contact me if you have any questions.

Sincerely,  
SPACECO, Inc.

A handwritten signature in black ink, appearing to read 'Robert J. Bielaski', followed by a horizontal line.

Robert J. Bielaski, P.E.  
Project Manager

cc: Paul Cohen – Principle Construction

**COMMENT 1:** If the original development plans for this property can be located in City archives, then the volume of stormwater detention identified on those plans will take precedence. If they cannot be located, the existing volume as calculated by the design engineer will be appropriate.

**RESPONSE 1:** Noted. If the City is able to locate the original development plans, we will provide the stormwater detention required on those plans. If the City is unable to locate those plans, we will provide stormwater detention to meet the current volume provided on-site. Per the DuPage County Ordinance, post construction stormwater BMPs will be required if the impervious coverage of the site is increased by 2,500 s.f. or more. Additionally, site runoff storage will be required if the impervious coverage of the site is increased by 25,000 s.f. or more.

The proposed development will not increase the existing impervious coverage by more than 2,500 s.f. Therefore, no post construction stormwater BMPs or site runoff storage are required to be provided.

**COMMENT 2:** It is our understanding that City staff will determine if the property will have to be resubdivided.

**RESPONSE 2:** If the City requires the property to be subdivided, a Plat of Subdivision will be prepared.

**COMMENT 3:** It should be clarified if any of the proposed sanitary sewer will be public or if it will all be a private service.

**RESPONSE 3:** The sanitary sewer is proposed as a private service to serve both buildings.

**COMMENT 4:** The City should consider if the sanitary sewer could be extended to the west property line to serve the Public Works building.

**RESPONSE 4:** We will await the City's decision as to whether they will require a sewer extension to serve the Public Works building. If the City requests a sewer extension, we will work with the City to provide the service.

**COMMENT 5:** We suggest that it be required to televise the existing storm sewers to determine their condition.

**RESPONSE 5:** If requested by the City, the petitioner agrees to televise the existing storm sewers.

**COMMENT 6:** Depending on the amount of stone in the existing storm sewer, it may be appropriate to consider measures to correct this.

**RESPONSE 6:** If after televising the onsite storm sewers it is determined that they need to be cleaned, we agree to clean the onsite storm sewers.

**COMMENT 7:** Because of the proximity to the adjacent wetlands and floodplain, DuPage County will have to review the proposed development to determine potential impacts.

**RESPONSE 7:** A pre-application meeting has already taken place with DuPage County. Once final documents are prepared, we will submit to DuPage County for review of the wetlands and floodplain.

**COMMENT 8:** DuPage County will review the proposed sanitary connection.

**RESPONSE 8:** Noted. We will obtain the necessary approval and permit with DuPage County prior to making the sanitary connection.

**COMMENT 9:** DuPage County will review the proposed water connection.

**RESPONSE 9:** Noted. We will obtain the necessary approval and permit with DuPage County prior to making the water connections.

**COMMENT 10:** We understand the City is determining if this section of Frontage Road is under City or IDOT jurisdiction.

**RESPONSE 10:** IDOT has determined that Frontage Road is not their jurisdiction. Frontage Road is under the jurisdiction of the City.

**COMMENT 11:** The existing well and septic system will have to be removed/abandoned in accordance with DuPage County Health Department regulations.

**RESPONSE 11:** Noted. Well and septic systems will be removed/abandoned in accordance with DuPage County Health Department regulations.



**CHRISTOPHER B. BURKE ENGINEERING, LTD.**

9575 West Higgins Road Suite 600 Rosemont Illinois 60018 TEL. (847) 823-0500 FAX (847) 323-0520

July 21, 2015

City of Darien  
1702 Plainfield Road  
Darien, IL 60561

Attention: Mike Griffith

Subject: Illinois Auto Central: 1033-1035 S. Frontage Road  
(CBBEL Project No. 950323H184)

Dear Mike:

As requested in your transmittal dated July 8, 2015, we have reviewed the preliminary plans for the aforementioned project. Please note that the design engineer, Spaceco, Inc., is an affiliate company of Christopher B. Burke Engineering, Ltd. (CBBEL). The following comments are submitted for your consideration.

1. If the original development plans for this property can be located in City archives, then the volume of stormwater detention identified on those plans will take precedence. If they cannot be located, the existing volume as calculated by the design engineer will be appropriate.
2. It is our understanding that City staff will determine if the property will have to be resubdivided.
3. It should be clarified if any of the proposed sanitary sewer will be public or if it will all be a private service.
4. The City should consider if the sanitary sewer could be extended to the west property line to serve the Public Works building.
5. We suggest that it be required to televise the existing storm sewers to determine their condition.
6. Depending on the amount of stone in the existing storm sewer, it may be appropriate to consider measures to correct this.
7. Because of the proximity to the adjacent wetlands and floodplain, DuPage County will have to review the proposed development to determine potential impacts.
8. DuPage County will review the proposed sanitary connection.
9. DuPage County will review the proposed water connection.

10. We understand the City is determining if this section of Frontage Road is under City or IDOT jurisdiction.
11. The existing well and septic system will have to be removed/abandoned in accordance with DuPage County Health Department regulations.

If you have any questions, please feel free to contact me.

Sincerely,



Daniel L. Lynch, PE, CFM  
Head, Municipal Engineering Department





## **INTRODUCTION**

At the request of Illinois Auto Electric Company, Optimum Safety Management performed a noise survey at the property located at 1033 S. Frontage Rd., Darien, IL, on the evening of Thursday, August 13, 2015, and the morning of Friday, August 14, 2015. The noise survey was performed in order to document ambient noise levels present on the property and the noise levels produced by the Thermo King refrigeration unit and a tractor-truck. These noise levels were recorded at specific locations on-site, as well as off-site at eleven (11) locations throughout the surrounding area and residential subdivisions. A trailer, equipped with a Thermo King refrigeration unit found in photo 14 of Appendix 3, was staged on the property during the noise survey on both occasions. Recordings were documented while the unit was both on and off. In addition, a tractor-truck was present during the second occasion in order to capture the noise level of an idling tractor engine alone, and in combination with the refrigeration unit.

Noise levels were taken and recorded by Doug Anderson, representing Optimum Safety Management, on Thursday, August 13, 2015 and Friday, August 14, 2015.

## **NOISE LEVEL SURVEY**

The purpose of this report is to describe noise levels associated with the various locations on the property, surrounding area and residential subdivisions.

### Sample Size

The sample size consisted of eight (8) locations onsite at different increments from the staged refrigeration unit, as well as four (4) property lines. Photographs at these locations can be viewed in Appendix 3, photos 1-13. Distances of the eight locations onsite were measured using a measuring wheel, shown in Appendix 3, photo 11. In addition, eleven (11) offsite locations were sampled. These locations are identified in Appendix 1 – NOISE STUDY MAP. The twenty-three (23) total locations were sampled twice on two (2) occasions.

A noise sample of a 2007 International 8600 Tractor, depicted in photo 16 of Appendix 3, can be found in Appendix 2 – NOISE STUDY DATA table dated on August 14, 2015. In addition, the combination noise sample, depicted in photo 17 of Appendix 3, can be found in Appendix 2 – NOISE STUDY DATA table dated on August 14, 2015.

### Sampling Equipment

The equipment used to perform the noise survey consisted of a Quest Edge 4 Sound Level Meter. Field calibrations were performed prior to and after the surveys with a Quest QC-10 Acoustical Calibrator. The noise level meter was programmed as follows:

Criterion: 90 dB  
Exchange Rate: 5 dB  
Upper Measurement Limit 115 dB  
Weighting: "A"  
Response: Slow

Copies of the instrument calibration certificates are provided in Appendix 4.

## Conditions

August 13, 2015 – Clear weather conditions existed throughout the evening. An increase of insect activity along the South property line was experienced at dusk. Moderate vehicular traffic was present on Interstate 55 throughout the sampling period. While sampling along the North property line and along S. Frontage Rd, direct reads of the sound level meter varied between 68 dB – 76 dB. This was clearly due to the type of vehicular traffic passing the test locations (i.e. tractor-trailers, motorcycles...).

August 14, 2015 – Clear weather conditions existed throughout the morning. Moderate vehicular traffic was present on Interstate 55 throughout the sampling period. While sampling along the North property line and along S. Frontage Rd, direct reads of the sound level meter varied between 68 dB – 76 dB. This was clearly due to the type of vehicular traffic passing the test locations (i.e. tractor-trailers, motorcycles...).

## **RESULTS**

The tables located in Appendix 2 – NOISE STUDY DATA provide results of each sample taken. The table identifies the locations of the tests, the corresponding numbers with the map in Appendix 1 – NOISE STUDY MAP, the date, time of the readings and results while the refrigeration unit was on and off.

## **CONCLUSIONS**

The following conclusions were reached regarding noise exposure monitoring:

August 13, 2015 – Based on the data recorded during the noise survey performed in the evening while the Thermo King refrigeration unit was on versus off, the noise produced by the refrigeration unit was detectable at the distances of 0' and 10' from the Thermo King refrigeration unit. None of the other readings taken onsite and offsite varied excessively while the Thermo King refrigeration unit was on or off.

August 14, 2015 – Based on the data recorded during the noise survey performed in the morning while the Thermo King refrigeration unit was on versus off, the noise produced by the refrigeration unit was detectable at the distances of 0', 10' and 25' from the Thermo King refrigeration unit. None of the other readings taken onsite and offsite varied excessively while the Thermo King refrigeration unit was on or off. In addition, there was a slight increase in noise levels at distances of 0', 10' and 25' while both the tractor-truck and Thermo King refrigeration were on and connect to each other.

Respectfully submitted,

*Douglas A. Anderson*

Douglas A. Anderson, CHST  
Safety Professional

**APPENDIX 1**

**NOISE STUDY MAP**

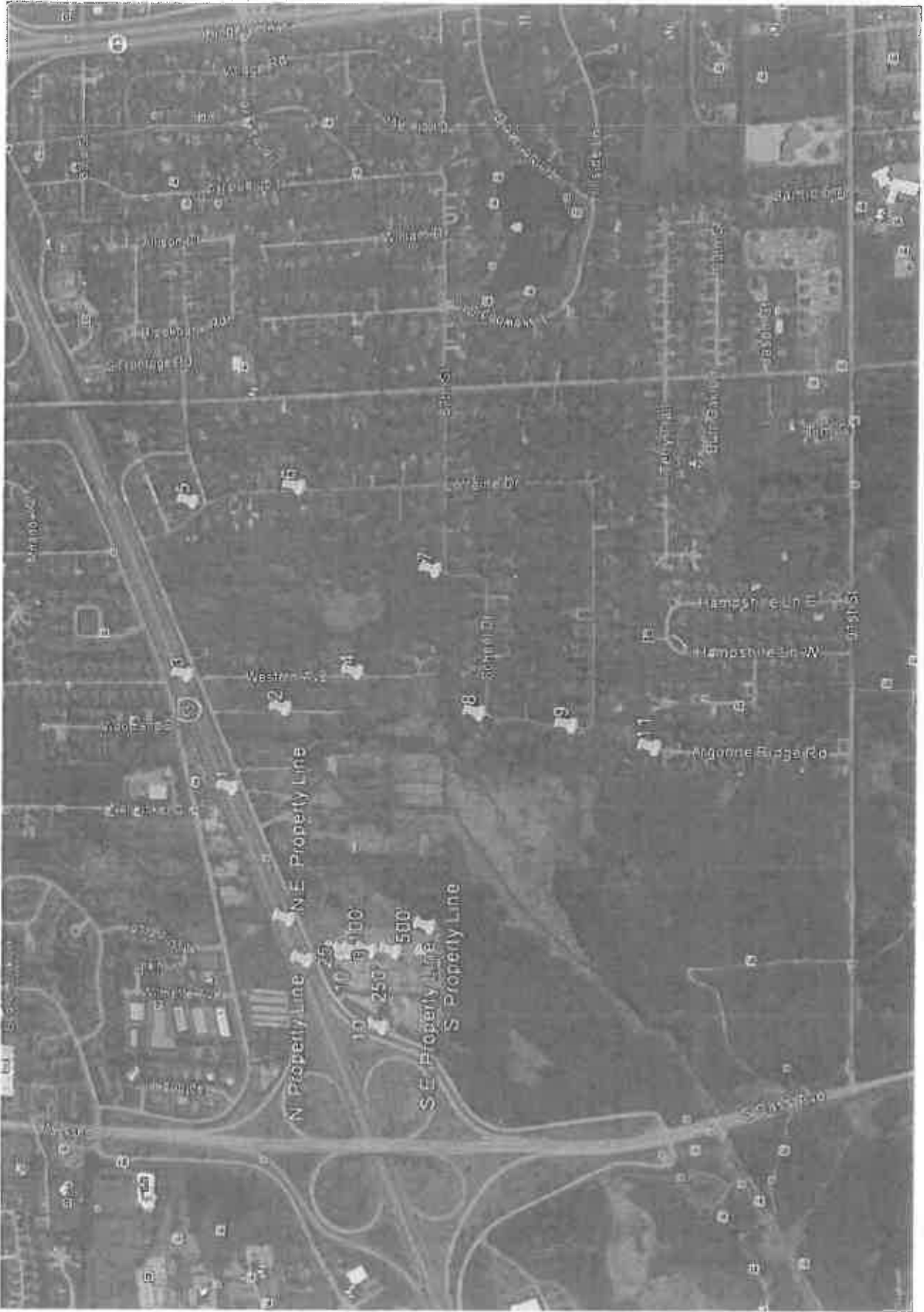

**APPENDIX 2**  
**NOISE STUDY DATA**

**Noise Assessment Conducted at 1033 S. Frontage Rd. Darien IL (8/13/2015)**

<u>On-Site Readings</u>	<u># on Map</u>	<u>Date</u>	<u>Time</u>	<u>Reading TK Unit Off</u>	<u>Time</u>	<u>Reading TK Unit On</u>
0 Feet From TK Unit	0	8/13/2015	8:22pm	66.8	8:00pm	80.6
10' From TK Unit	10	8/13/2015	8:23pm	67.3	8:00pm	74.0
25' From TK Unit	25	8/13/2015	8:24pm	68.8	8:00pm	69.1
50' From TK unit	50	8/13/2015	8:24pm	65.5	8:01pm	65.7
100' From TK Unit	100	8/13/2015	8:25pm	67.2	8:02pm	65.5
200' From TK Unit	200	8/13/2015	8:26pm	66.0	8:04pm	64.8
250' From TK Unit	250	8/13/2015	8:27pm	65.8	8:05pm	63.5
500' From TK Unit	500	8/13/2015	8:29pm	64.5	8:07pm	63.4
S. Property Line - 655'		8/13/2015	8:30pm	64.8	8:09pm	63.1
S.E. Property Line		8/13/2015	8:31pm	65.2	8:10pm	66.4
N. Property Line		8/13/2015	8:35pm	73.5	8:14pm	73.0
N.E. Property Line		8/13/2015	8:37pm	73.4	8:17pm	72.4

**Off-Site Readings**

S. Fontage Rd.	1	8/13/2015	8:43pm	73.3	9:11pm	74.0
Leonard Ct.	2	8/13/2015	8:45pm	67.1	9:12pm	67.3
S. Fontage Rd.	3	8/13/2015	8:47pm	73.1	9:15pm	73.3
Western Ave.	4	8/13/2015	8:49pm	63.2	9:16pm	63.1
Lorraine Dr. & Fern St.	5	8/13/2015	8:51pm	63.9	9:19pm	63.2
Lorraine Dr.	6	8/13/2015	8:53pm	63.6	9:20pm	63.7
87th St. & Scheel	7	8/13/2015	8:54pm	67.9	9:22pm	66.8
Leonard Dr.	8	8/13/2015	8:55pm	63.1	9:23pm	63.1
Leonard Dr.	9	8/13/2015	8:56pm	63.1	9:24pm	63.1
Darien Public Works Driveway	10	8/13/2015	9:05pm	67.3	9:33pm	67.2
Argonne Ridge Rd.	11	8/13/2015	9:01pm	63.1	9:30pm	63.1

Pre-Calibration: 114 dB

Post-Calibration: 113.9 dB

**Noise Assessment Conducted at 1033 S. Frontage Rd. Darien IL (8/14/2015)**

On-Site Readings	# on Map	Date	Reading		Reading TK		Tractor		Tractor &	
			Time	TK Unit Off	Time	Unit On	Time	Only	Time	TK Unit On
0 Feet From TK Unit	0	8/14/2015	8:25am	68.5	8:08am	81.9	9:33am	83.1	9:30am	83.5
10' From TK Unit	10	8/14/2015	8:25am	67.8	8:09am	75.0	9:34am	77.2	9:30am	79.1
25' From TK Unit	25	8/14/2015	8:26am	67.2	8:09am	71.0	9:34am	71.1	9:31am	73.1
50' From TK unit	50	8/14/2015	8:27am	67.4	8:10am	69.7	9:35am	68.2	9:32am	68.2
100' From TK Unit	100	8/14/2015	8:27am	68.0	8:10am	68.6	9:36am	67.6	9:33am	67.2
200' From TK Unit	200	8/14/2015	8:28am	66.4	8:11am	67.4				
250' From TK Unit	250	8/14/2015	8:29am	66.1	8:12am	66.9				
500' From TK Unit	500	8/14/2015	8:30am	64.9	8:14am	64.3				
S. Property Line - 655'		8/14/2015	8:31am	63.4	8:15am	63.1				
S.E. Property Line		8/14/2015	8:32am	64.0	8:16am	63.9				
N. Property Line		8/14/2015	8:36am	76.4	8:20am	77.5				
N.E. Property Line		8/14/2015	8:38am	74.5	8:22am	74.5				

**Off-Site Readings**

S. Frontage Rd.	1	8/14/2015	8:42am	76.3	9:06am	74.7				
Leonard Ct.	2	8/14/2015	8:43am	66.8	9:07am	67.2				
S. Frontage Rd.	3	8/14/2015	8:45am	74.6	9:09am	76.5				
Western Ave.	4	8/14/2015	8:46am	63.1	9:10am	63.1				
Lorraine Dr. & Fern St.	5	8/14/2015	8:48am	65.3	9:12am	63.1				
Lorraine Dr.	6	8/14/2015	8:49am	63.1	9:13am	63.1				
87th St. & Scheel	7	8/14/2015	8:51am	63.1	9:14am	63.1				
Leonard Dr.	8	8/14/2015	8:52am	63.1	9:16am	63.1				
Leonard Dr.	9	8/14/2015	8:53am	63.1	9:17am	63.1				
Darien Public Works Driveway	10	8/14/2015	9:01am	69.7	9:25am	66.8				
Argonne Ridge Rd.	11	8/14/2015	8:58am	63.1	9:22am	63.1				

Pre-Calibration: 114 dB

Post-Calibration: 114.2 dB



## **APPENDIX 3**

### **NOISE STUDY PHOTOGRAPHS**



1



2



3



4

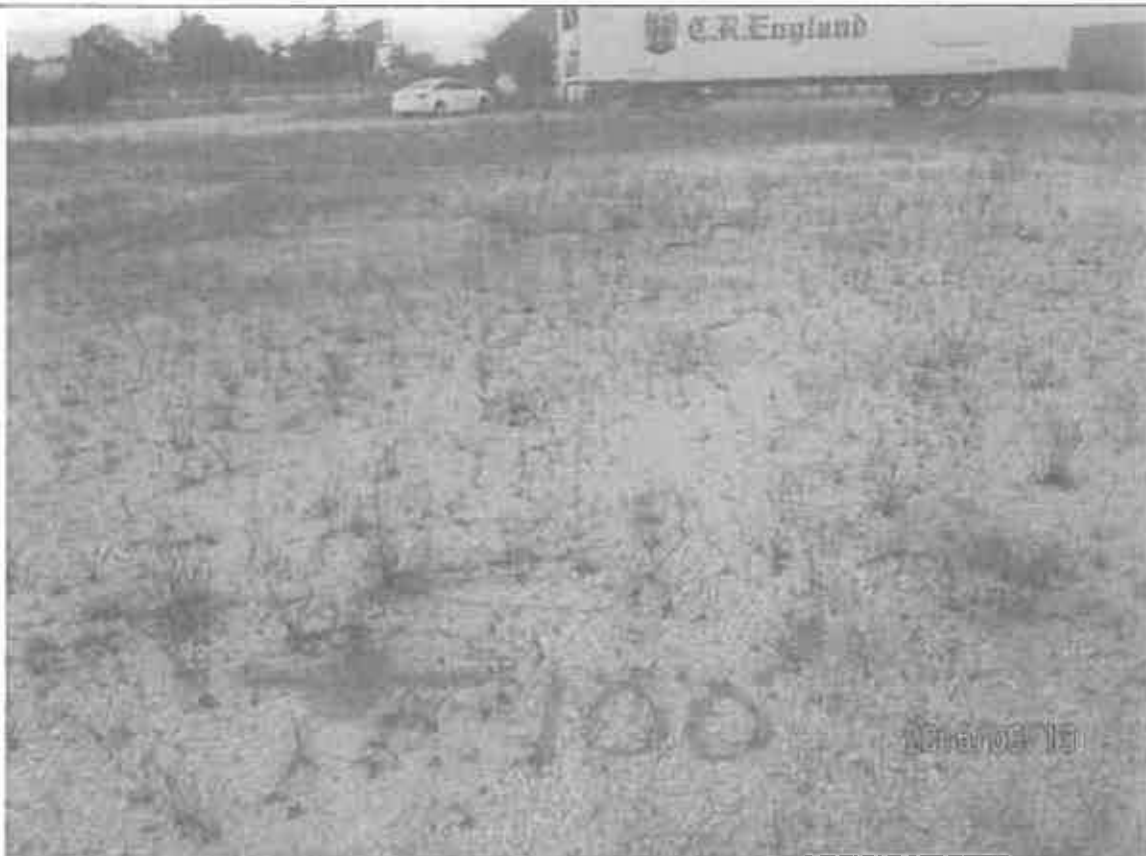

5



6



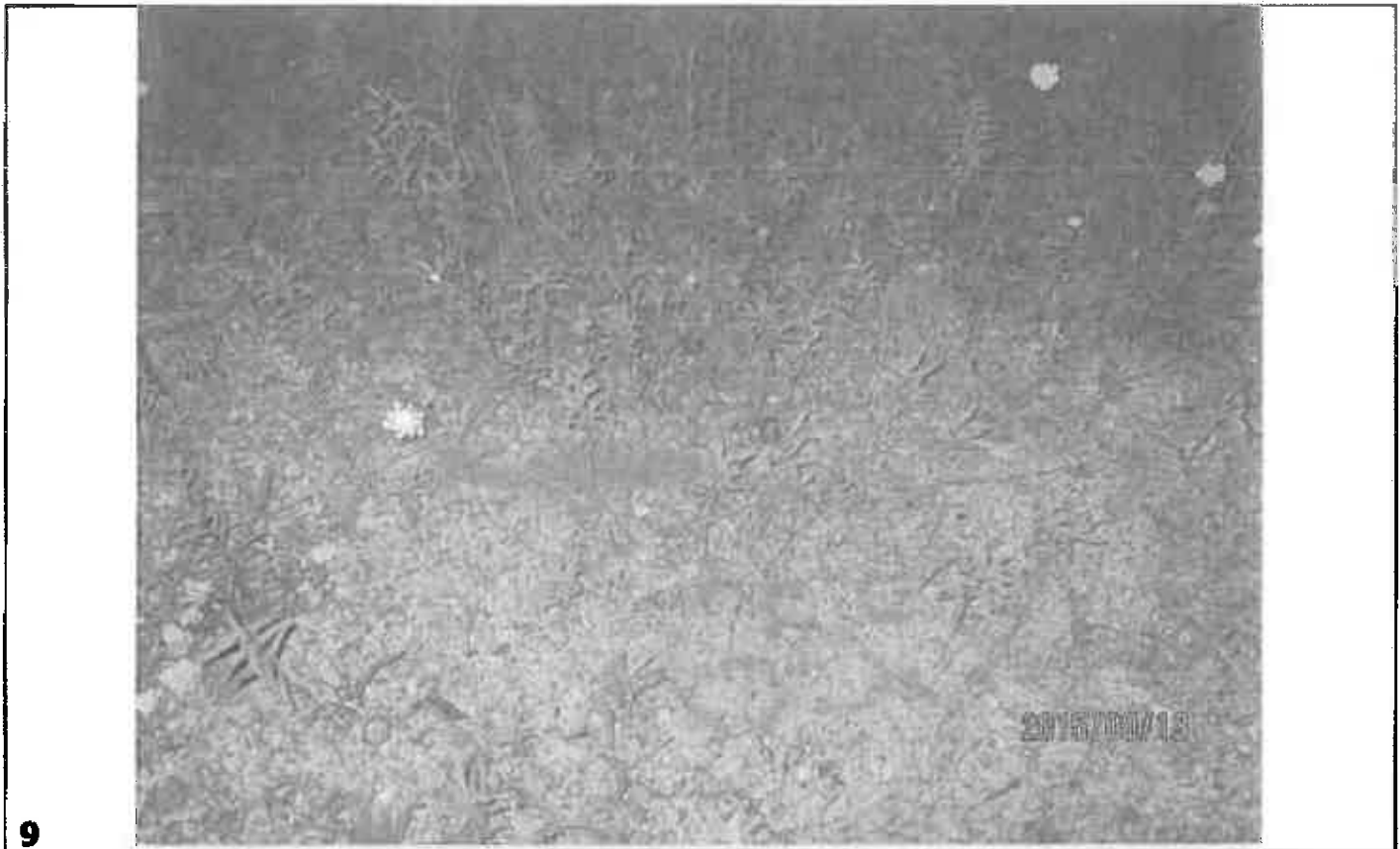

9

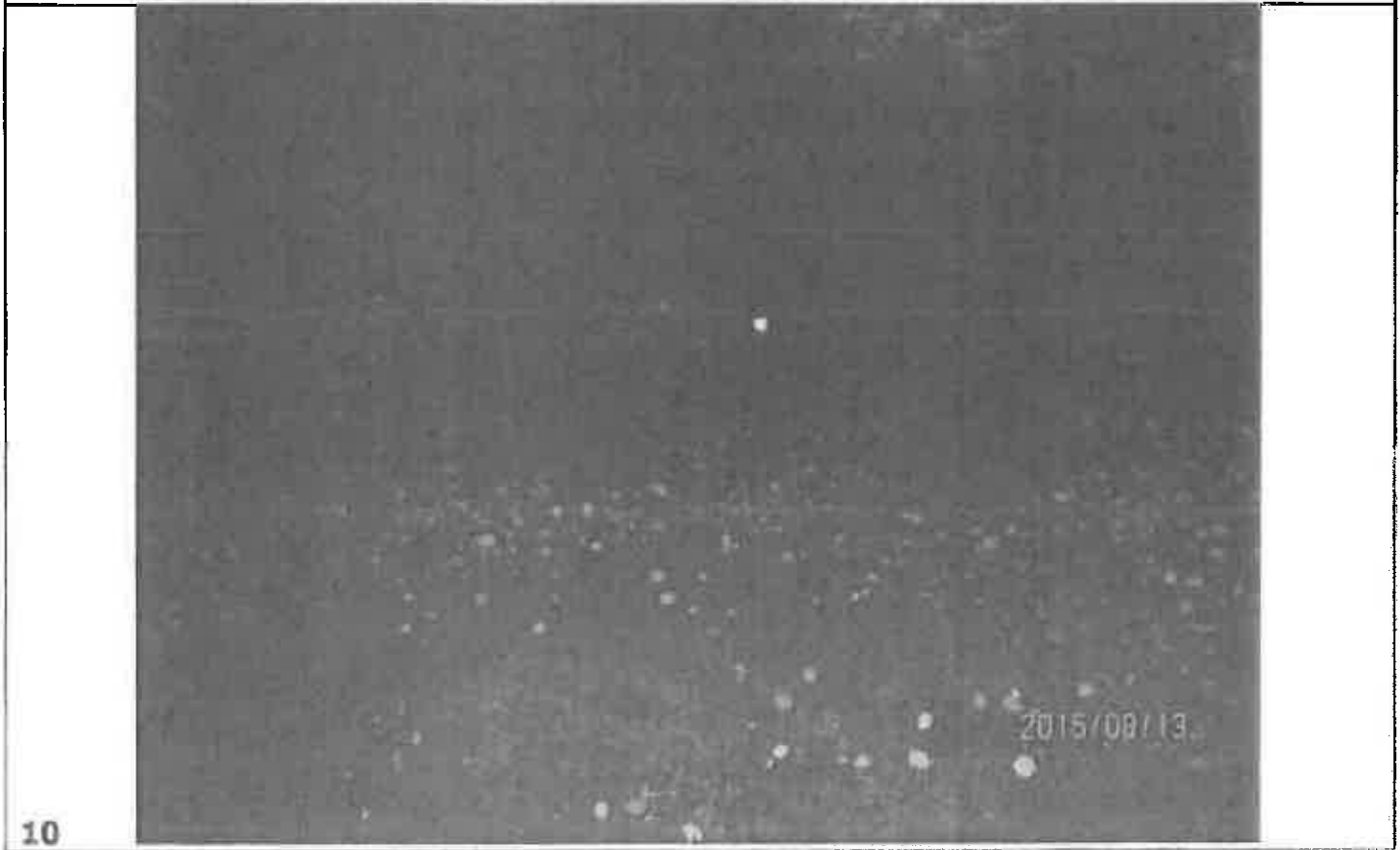

10

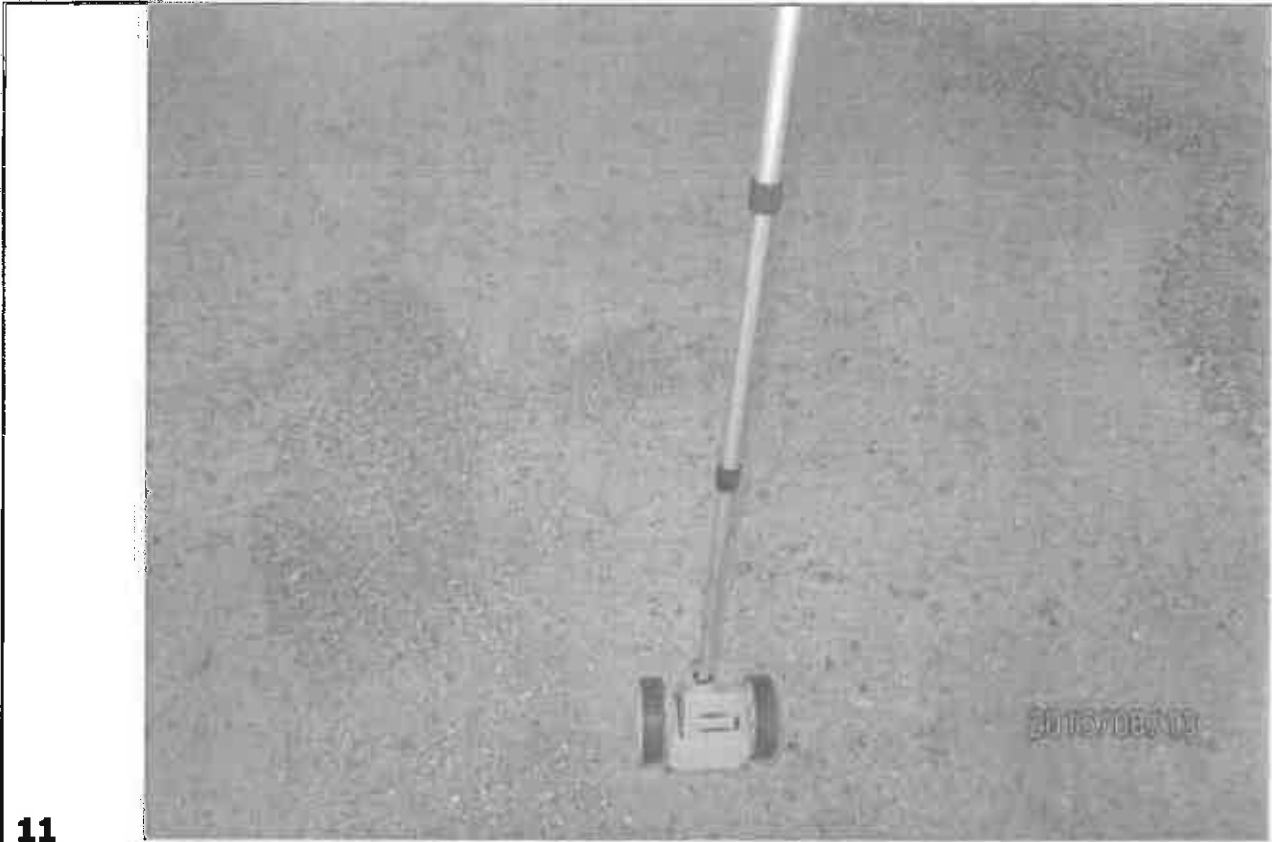

11



12



13



14





15



16



17

## **APPENDIX 4**

### **EQUIPMENT CALIBRATION DOCUMENTS**

## Calibration Certificate No. 0000647

<b>Instrument:</b> Sound Level Meter	<b>Date Calibrated:</b> 4/22/2015	<b>Cal Due:</b> 04/22/2016				
<b>Model:</b> Edge4	<b>Status:</b>	<table border="1" style="display: inline-table; border-collapse: collapse;"> <tr> <td style="width: 50%; text-align: center;">Received</td> <td style="width: 50%; text-align: center;">Sent</td> </tr> <tr> <td style="text-align: center;">X</td> <td style="text-align: center;">X</td> </tr> </table>	Received	Sent	X	X
Received	Sent					
X	X					
<b>Manufacturer:</b> Quest	<b>In tolerance:</b>					
<b>Serial number:</b> EHJ040047	<b>Out of tolerance:</b>					
<b>Tested with:</b> Microphone Microphone s/n 480033	<b>See comments:</b>					
<b>Type (class):</b> 2	<b>Contains non-accredited tests:</b> ___ Yes <input checked="" type="checkbox"/> No					
<b>Customer:</b>	<b>Calibration service:</b> ___ Basic <input checked="" type="checkbox"/> Standard					
<b>Tel/Fax:</b> /	<b>Address:</b>					

Tested in accordance with the following procedures and standards:  
 Calibration of Sound Level Meters, Scantek Inc., Rev. 6/22/2012  
 SLM & Dosimeters – Acoustical Tests, Scantek Inc., Rev. 7/6/2011

Instrumentation used for calibration: Nor-1504 Norsonic Test System:

Instrument - Manufacturer	Description	S/P1	Cal. Date	Traceability evidence Cal. Lab / Accreditation	Cal. Due
4838-Norsonic	SME Cal Unit	31079	Jan 28, 2015	Norsonic SA	Jan 28, 2017
D5-360-SRS	Function Generator	129268	Jan 28, 2015	SRS	Jan 28, 2016
34401A-Agilent Technologies	Digital Voltmeter	MY53003818	Jan 11, 2014	Agilent Provider #93107	Jan 11, 2016
SD700-Extech	Meteo Station	Q769118	Feb 18, 2014	INNOCAL	Feb 18, 2016
FC Program 1019 Norsonic	Calibration software	v.6.1T	Validated Nov 2014	Scantek, Inc.	-
1251-Norsonic	Calibrator	34103	May 27, 2014	Scantek, Inc./ NNLAP	May 27, 2015

Instrumentation and test results are traceable to SI (International System of Units) through standards maintained by NIST (USA) and NPL (UK).

**Environmental conditions:**

Temperature (°C)	Barometric pressure (kPa)	Relative Humidity (%)
23.0	98.00	32.0

Calibrated by:	Steven Boertmann	Authorized signatory:	CM
Signature	STEVEN BOERTMANN	Signature	CHRIS MCEVOY
Date	4-22-15	Date	4-22-15

Calibration Certificates or Test Reports shall not be reproduced, except in full, without written approval of the laboratory.

Document stored C:\Nor1504\Slm\2014\QEdge3-4 as received\_EHJ040047\_M1.doc

Page 1 of 2

Results summary: Device complies with following clauses of mentioned specifications:

CLAUSES <sup>1</sup> FROM IEC/ANSI STANDARDS REFERENCED IN PROCEDURES:	RESULT <sup>2,3</sup>	EXPANDED UNCERTAINTY (coverage factor 2) [dB]
INDICATION AT THE CALIBRATION CHECK FREQUENCY - ANSI S1.4 CLAUSE 8.2	Passed	0.20.15
LEVEL LINEARITY TEST - ANSI S1.4-1983, CLAUSE 6.9 & 6.10	Passed	0.25
WEIGHTING NETWORK TEST: A NETWORK - ANSI S1.4-1983 CLAUSE 8.2.1	Passed	0.25
OVERLOAD DETECTOR TEST: A-NETWORK - ANSI S1.4-1983 CLAUSE 8.3.1	Passed	0.25
F/S//PEAK TEST: STEADY STATE RESPONSE - ANSI S1.4 1983 CLAUSE 6.4	Passed	0.25
FAST-SLOW TEST: OVERSHOOT TEST - ANSI S1.4 1983 CLAUSE 8.4.1	Passed	0.25
SINGLE SINE WAVE BURST - ANSI S1.4 1983 CLAUSE 8.4.1 & 8.4.3	Passed	0.25
RMS DETECTOR TEST: CONTINUOUS SINE WAVE BURST - ANSI S1.4-1983 CLAUSE 8.4.2	Passed	0.25
SUMMATION OF ACOUSTIC TESTS - ANSI S1.4 CLAUSE 5 USING MF CALIBRATOR	Passed	0.2-0.5

<sup>1</sup> The results of this calibration apply only to the instrument type with serial number identified in this report.

<sup>2</sup> Parameters are certified at actual environmental conditions.

<sup>3</sup>

Comments: The instrument was tested and met all specifications found in the referenced procedures.

Note: The instrument was tested for the parameters listed in the table above, using the test methods described in the listed standards. All tests were performed around the reference conditions. The test results were compared with the manufacturer's or with the standard's specifications, whichever are larger. Compliance with any standard cannot be claimed based solely on the periodic tests.

Tests made with the following attachments to the instrument:

Microphone:	Quest Microphone s/n 480033 for acoustical test
Pre-amplifier:	none
Cable:	line adaptor ADP005 (100ft) for electrical tests and 1448 (100ft) for noise test
Accompanying acoustical calibrator:	Quest QC-10 s/n QIL020009
Windscreen:	none

Measured Data: in Test Report # of ... pages.

Place of Calibration: Argus Hazco  
46410 Continental Dr.  
Chesterfield, MI 48047

Ph/Fax: 586-840-3220/ -3221  
[www.argus-hazco.com](http://www.argus-hazco.com)

Calibration Certificates or Test Reports shall not be reproduced, except in full, without written approval of the laboratory.

Document stored C:\Nor1504\Sim\2014\QEdge3-4 as received\_EH040047\_M1.doc

Page 2 of 2

Edge4 s/n: EHJ040047 ID:  
Date: 4/22/2015 By: SB  
Due: 04/22/2016

# Calibration Certificate

0004956

**Instrument:** Acoustical Calibrator  
**Model:** QC-10  
**Manufacturer:** Quest  
**Serial number:** QIK030148  
**Class (IEC 60942):** 1  
**Barometer type:**  
**Barometer s/n:**

**Date Calibrated:** 5/21/2015 **Cal Due:** 5/21/2016  
**Status:**

Received	Sent
<input checked="" type="checkbox"/>	<input checked="" type="checkbox"/>

  
**In tolerance:**

<input checked="" type="checkbox"/>	<input checked="" type="checkbox"/>
-------------------------------------	-------------------------------------

  
**Out of tolerance:**

<input type="checkbox"/>	<input type="checkbox"/>
--------------------------	--------------------------

  
**See comments:**

<input type="checkbox"/>	<input type="checkbox"/>
--------------------------	--------------------------

  
**Contains non-accredited tests:**  Yes  No

**Customer:**  
**Tel/Fax:** /

**Address:**

Tested in accordance with the following procedures and standards:  
 Calibration of Noise Dosimeters, Sound Meters, and Calibrators, Rev. Chf 04

Instrumentation used for calibration: Nor-1504 Norsonic Test System:

Instrument - Manufacturer	Description	S/N	Cal. Date	Traceability evidence	
				Cal. Lab / Accreditation	Cal. Due
483B-Norsonic	SNE Cal Unit	31079	Jan 28, 2015	Norsonic SA	Jan 28, 2017
DS-3ED-SRS	Function Generator	123266	Jan 28, 2015	SRS	Jan 28, 2016
34401A-Agilent Technologies	Digital Voltmeter	MYS300818	Jan 11, 2014	Agilent Provider #99107	Jan 11, 2016
SD700-Extech	Meteo Station	Q769118	Feb 18, 2014	INNOCAL	Feb 18, 2016
140-Norsonic	Real Time Analyzer	1405966	May 8, 2014	Norsonic SA	May 8, 2015
PC Program 1018 Norsonic	Calibration software	v.6.1T	Validated Nov 2014	Scantek, Inc.	-
60AG-GRAS	Microphone	173539	Apr 28, 2015	Scantek, Inc. / PVLAP	Apr 28, 2016
NP1203-Norsonic	Preamplifier	138531	Apr 28, 2015	Norsonic SA	Apr 28, 2016

Instrumentation and test results are traceable to SI (International System of Units) through standards maintained by NIST (USA) and NPL (UK)

<b>Calibrated by:</b>	Steven Boertmann	<b>Authorized signatory:</b>	Chris McEvoy
<b>Signature</b>	STEVEN BOERTMANN	<b>Signature</b>	CHRIS MCEVOY
<b>Date</b>	5-21-15	<b>Date</b>	5-21-15

Calibration Certificates or Test Reports shall not be reproduced, except in full, without written approval of the laboratory.  
 This Calibration Certificate or Test Reports shall not be used to claim product certification, approval or endorsement by NVLAP, NIST, or any agency of the federal government.  
 Document stored as: C:\Nor1504\Cal2014\Quest10\_QIK030148\_M1.doc

Results summary: Device was tested and complies with following clauses of mentioned specifications:

CLAUSES <sup>1</sup> FROM STANDARDS REFERENCED IN PROCEDURES:	MET <sup>2</sup>	NOT MET	COMMENTS
<i>Manufacturer specifications</i>			
Manufacturer specifications: Sound pressure level	X		
Manufacturer specifications: Frequency	X		
Manufacturer specifications: Total harmonic distortion	X		
<i>Current standards</i>			
ANSI S1.40:2006 B.3 / IEC 60942: 2003 B.2 - Preliminary inspection	X		Unit older than the standard
ANSI S1.40:2006 B.4.4 / IEC 60942: 2003 B.3.4 - Sound pressure level	X		Unit older than the standard
ANSI S1.40:2006 A.5.4 / IEC 60942: 2003 A.4.4 - Sound pressure level stability	-	-	Unit older than the standard
ANSI S1.40:2006 B.4.5 / IEC 60942: 2003 B.3.5 - Frequency	X		Unit older than the standard
ANSI S1.40:2006 B.4.6 / IEC 60942: 2003 B.3.6 - Total harmonic distortion	X		Unit older than the standard
<i>Older standards (obsolete)</i>			
IEC 60942: 1997 B.2 - Preliminary inspection	X		
IEC 60942: 1997 B.3.3 - Sound pressure level	X		
IEC 60942: 1997 B.3.4 - Sound pressure level stability	X		
IEC 60942: 1997 B.3.5 - Frequency	X		
IEC 60942: 1997 B.3.6 - Total harmonic distortion	X		
ANSI S1.40: 1984 (S1987) 4.6.2 Sound pressure level in the coupler	X		Not applicable
ANSI S1.40: 1984 (R1997) 4.6 Frequency sound in the coupler	X		Not applicable
ANSI S1.40: 1984 (R1997) 4.10 Total harmonic distortion	X		Not applicable

<sup>1</sup> The results of this calibration apply only to the instrument type with serial number identified in this report.

<sup>2</sup>

**Main measured parameters<sup>3</sup>:**

Measured <sup>4</sup> /Acceptable <sup>5</sup> Tone frequency (Hz):	Measured <sup>4</sup> /Acceptable <sup>5</sup> Total Harmonic Distortion (%):	Measured <sup>4</sup> /Acceptable Level <sup>2</sup> (dB):
994.07 ± 0.99/1000.0 ± 10.0	0.35 ± 0.10/ < 3	114.12 ± 0.14/114.0 ± 0.4

<sup>3</sup> The stated level is valid at measurement conditions.

<sup>4</sup> The above expanded uncertainties for frequency and distortion are calculated with a coverage factor k=2; for level k=2.00

<sup>5</sup> Acceptable parameters values are from the current standards

Barometer indication	Nominal indication

**Environmental conditions:**

Temperature (°C)	Barometric pressure (kPa)	Relative Humidity (%)
23.0 ± 1.0	100.00 ± 0.001	32.0 ± 2.0

**Tests made with following attachments to instrument:**

Calibrator 1/2" Adaptor Type:

Other:

**Adjustments:** Unit was not adjusted.

**Comments:** The instrument was tested and met all specifications found in the referenced procedures.

*Note:* The instrument was tested for the parameters listed in the table above, using the test methods described in the listed standards. All tests were performed around the reference conditions. The test results were compared with the manufacturer's or with the standard's specifications, whichever are larger.  
Compliance with any standard cannot be claimed based solely on the periodic tests.

Place of Calibration: Argus Hazco  
46410 Continental Dr.  
Chesterfield, MI 48047

Ph/Fax: 586-840-3220/ -3221  
[www.argus-hazco.com](http://www.argus-hazco.com)

Calibration Certificates or Test Reports shall not be reproduced, except in full, without written approval of the laboratory.  
This Calibration Certificate or Test Reports shall not be used to claim product certification, approval or endorsement by NVLAP, NIST, or any agency of the federal government.  
Document stored as: C:\Nor1504\Cal\2014\Quest10\_QHK030148\_M1.doc

Page 2 of 2

**MEMORANDUM TO:** Doug Calay  
Illinois Auto Central Thermo King

**FROM:** Michael Werthmann, PE, PTOE  
Principal

**DATE:** August 17, 2015

**SUBJECT:** Summary Traffic Evaluation  
Proposed Illinois Auto Central Thermo King  
Darien, Illinois

This memorandum presents the findings of a summary traffic evaluation conducted by Kenig, Lindgren, O'Hara, Aboona, Inc. (KLOA, Inc.) for the proposed Illinois Auto Central Thermo King (IACTK) facility to be located in Darien, Illinois. The site, which is zoned I-1 (heavy industrial) in the City of Darien, is located at 1033 South Frontage Road just east of the Darien Public Works Department facility. As proposed, the site will be redeveloped to contain an IACTK sales and service facility with a portion of the site leased to CR England for truck parking and storage. The proposed facility, including the CR England truck yard, will replace an existing facility located in Chicago, Illinois. Access to the facility is to be provided via the I-55 South Frontage Road.

The purpose of this evaluation was to examine the existing conditions of the South Frontage Road, determine the traffic characteristics of the facility and evaluate whether the South Frontage Road has sufficient capacity to accommodate the additional traffic.

## Existing Conditions

### South Frontage Road

The I-55 South Frontage Road is a two-lane road that serves as a local frontage road to I-55 and extends from just east of Clarendon Hills Road to just west of Woodward Avenue. Within the vicinity of the site, the South Frontage Road has curb and gutter provided at the access drives to the Darien Public Works Department facility and the existing site. Through truck traffic and trucks over five tons are prohibited on the South Frontage Road east of the site via a "Through Truck Traffic is Prohibited" sign and a "5-Ton Weight Limit" sign located along the eastbound lane of the South Frontage Road just east of the site. Both approaches of the South Frontage Road are under stop sign control at its intersection with Cass Avenue and both approaches of Fern Street (South Frontage Road) are under stop sign control at its intersection with Clarendon Hills Road. The South Frontage Road has a posted speed limit of 35 mph and is under the jurisdiction of the City of Darien.



## **Existing Traffic Counts**

To determine the existing traffic volumes along the South Frontage Road, daily traffic counts were obtained from the City of Darien. The traffic counts were performed just east of Cass Avenue from Wednesday, August 12 through Friday, August 14, 2015. The following summarizes the results of the traffic counts:

- The South Frontage Road had an average two-way traffic volume of approximately 1,500 vehicles per day with a maximum of approximately 1,700 vehicles per day.
- The South Frontage Road had a two-way volume of approximately 87 vehicles during the morning peak hour (6:30 to 7:30 A.M.) and approximately 235 vehicles during the evening peak hour (5:30 to 6:30 P.M.).

## **Facility Traffic Characteristics**

### **Proposed Facility and Site Plan**

As proposed, the site will be redeveloped and contain two buildings. The largest building will be the IACTK shop/office and warehouse and the second building will be leased to CR England. IACTK is a factory-authorized sales and service dealer for Thermo King which is a producer of transport temperature control and auxiliary power units. The facility is proposed to provide service and repairs for the units, a retail showroom for customers to view and purchase related parts and accessories, office and support space and a warehouse that will receive and distribute all parts related to the sales and service operations. CR England is a customer of IACTK and will lease a portion of the site to park their commercial tractors and trailers.

As proposed, the site will provide approximately 90 off-street parking spaces. The truck yard will provide approximately 106 spaces for CR England trucks and approximately 101 spaces for IACTK trucks. Access to the development is proposed to be provided via three full access drives on the South Frontage Road.

### **Directional Distribution**

Given the truck restrictions along the South Frontage Road, all of the truck traffic will access the site via the west on the South Frontage Road and its intersection with Cass Avenue. No truck traffic will be allowed to access the site via the east on the South Frontage Road. It is anticipated that the majority of the truck traffic will be traveling to and from the area via I-55. While I-55 can experience congestion, particularly during the morning and evening peak periods, it is expected that the truck traffic will still use I-55 to access the facility as opposed to traversing the local roadway system.

## **Trip Generation**

According to IACTK, the facility is anticipated to have a total of approximately 39 employees that will typically work one of the following three shifts:

- Approximately 28 employees will work from 7:00 A.M. to 3:30 P.M.
- Approximately 8 employees will work from 3:00 P.M. to 11:30 P.M.
- Approximately 3 employees will work from 11:00 P.M. to 7:30 A.M.

CR England is anticipated to have a total of 60 to 65 drivers that will typically work one of the following three shifts:

- Approximately 16 drivers will work from 4:00 A.M. to 12:00 P.M.
- Approximately 42 drivers will work from 12:00 P.M. to 8:00 P.M.
- Approximately 7 drivers will work from 8:00 P.M. to 4:00 A.M.

In addition, CR England is anticipated to have approximately 8 employees that will work one of three shifts. Other than the IACTK morning shift, very few of the employees/drivers are expected to arrive at or depart from the facility during the weekday morning or evening commuter peak hours.

The volume of truck traffic projected to be generated by the facility was based on the operation of the existing IACTK facility located in Chicago which is to be relocated to the subject site. Table 1 shows the number of truck trips generated by the existing facility on August 10, 2015 during the morning and evening commuter peak hours along the South Frontage Road and per day. In addition, Table 2 provides a breakdown of the type of trucks that were generated by the facility. The following summarizes the volume of truck traffic anticipated to be generated by the facility:

- The facility is anticipated to generate approximately 225 total truck trips per day. However, it is important to note that the truck traffic will be distributed throughout the day with the facility anticipated to generate a maximum of approximately 22 truck trips in any one hour.
- The facility is anticipated to generate a limited volume of truck trips during the critical morning and evening commuter peak hours with a total of approximately 7 trips during the morning peak hour and 9 trips during the evening peak hour.
- Approximately 47 percent of the truck trips consisted of single unit trucks and 53 percent consisted of semi-trailers. As such, only approximately 50 percent of the truck traffic is anticipated to consist of the larger semi-trailers.

**Table 1**  
**PROJECTED TRUCK TRAFFIC**

	Morning Peak Hour			Evening Peak Hour			Daily		
	In	Out	Total	In	Out	Total	In	Out	Total
IACKT	1	1	2	2	1	3	42	38	80
CR England	1	4	5	3	3	6	67	78	145
Total	2	5	7	5	4	9	109	116	225

**Table 2**  
**TYPE OF TRUCK TRAFFIC**

Type of Truck	Total Daily Volume	Percentage
Single Unit Truck	15	7%
Single Unit Tractor	91	40%
Semi-Trailer (Tractor and Trailer)	119	53%
Total	225	100%

### Traffic Evaluation

Based on the average daily traffic counts provided by the City of Darien, the South Frontage Road had a maximum daily traffic volume of approximately 1,700 vehicles. Further, the road had a morning peak hour (6:30 to 7:30 A.M.) two-way volume of 87 vehicles and an evening peak hour (5:30 to 6:30 P.M.) two-way volume of 235 vehicles. Given that a typical two-lane road has a capacity of approximately 10,000 vehicles per day, the South Frontage Road is currently utilizing only approximately 17 percent of the roadway's daily capacity.

Based on the existing operation in Chicago, the facility is anticipated to generate approximately 225 total truck trips per day. However, it is important to note that the truck trips will be distributed throughout the day and will consist of approximately 50 percent single unit vehicles and 50 percent semi-trailers. More important, the facility is anticipated to generate a limited volume of traffic during the critical morning and evening commuter peak hours with a total of approximately 7 trips during the morning peak hour and 9 trips during the evening peak hour. Finally, other than the IACKT morning shift, very few of the employees/drivers are expected to arrive at or depart from the facility during the weekday morning or evening commuter peak hours. The total traffic anticipated to be generated by the facility will only utilize approximately 5 percent of the total daily capacity of the South Frontage Road.

With the addition of the facility-generated traffic, the South Frontage Road is anticipated to be operating at only approximately 22 percent of the roadway's capacity. Furthermore, the facility is projected to add only a limited volume of peak hour traffic. Therefore, it can be seen that the South Frontage Road has sufficient reserve capacity to accommodate the additional traffic to be generated by the proposed facility. Finally, as previously indicated, truck traffic is anticipated to travel to/from the west on the South Frontage Road given the location of the I-55 ramps along Cass Avenue and the fact that trucks are restricted from traveling east along the frontage road just east of the site.

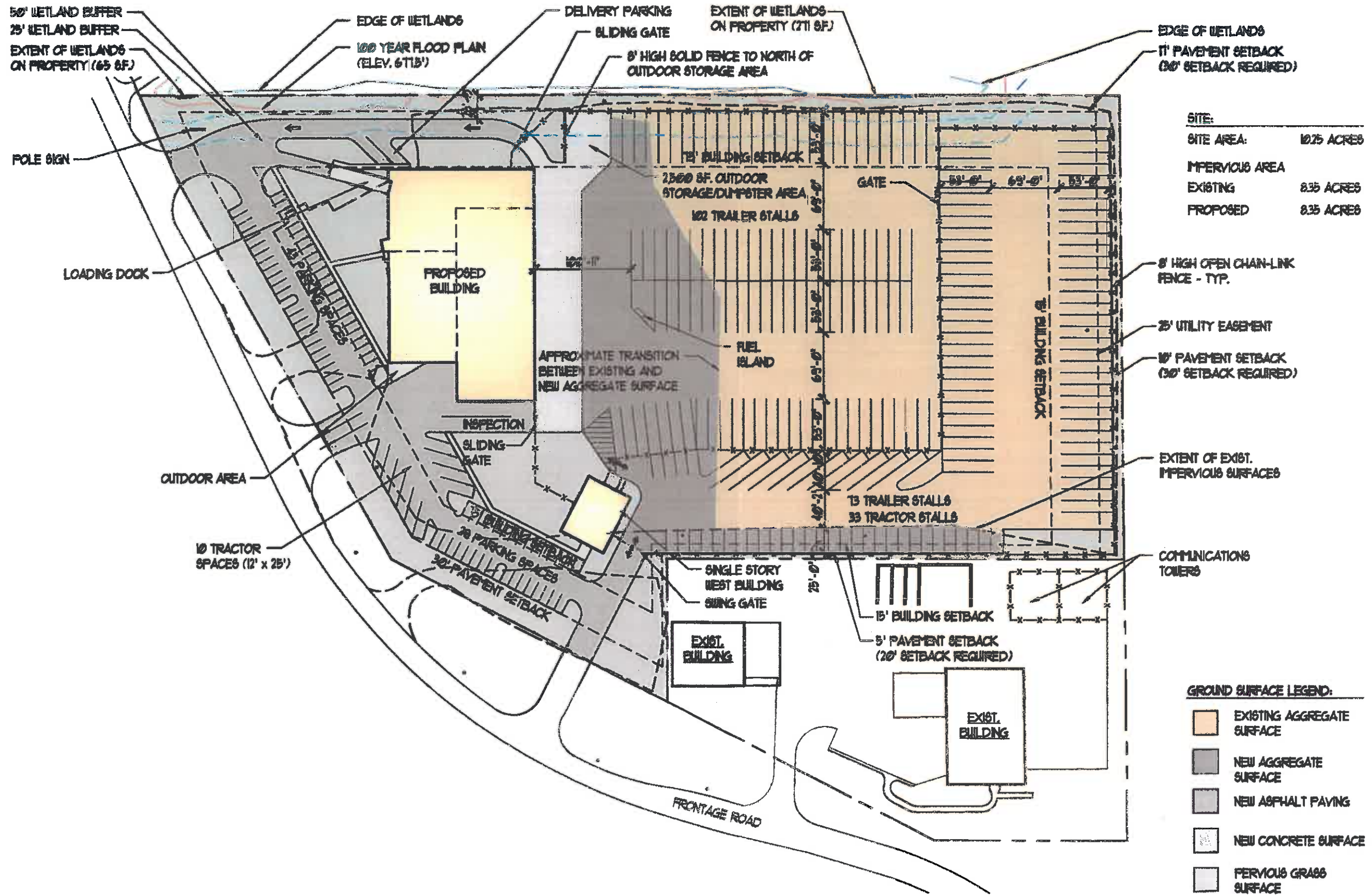

**1 PROPOSED SITE PLAN**  
 ALL 1" = 100'-0"

ILLINOIS AUTO CENTRAL THERMO KING  
 Cass Ave. & I-55, Darien, IL  
 PROPOSED SITE PLAN

2610 Lake Creek Road  
 Suite 200  
 Rosewood, Illinois 60015  
 Ph: (847) 940-0300  
 Fax: (847) 940-1045

**Partners in Design**  
 ARCHITECTS



PROJECT NO:  
**535.14.112**  
 DRAWN BY: **CTS** CHECKED BY: **UHB**  
 DATE: **08.14.15**  
 SHEET NO:

ALL



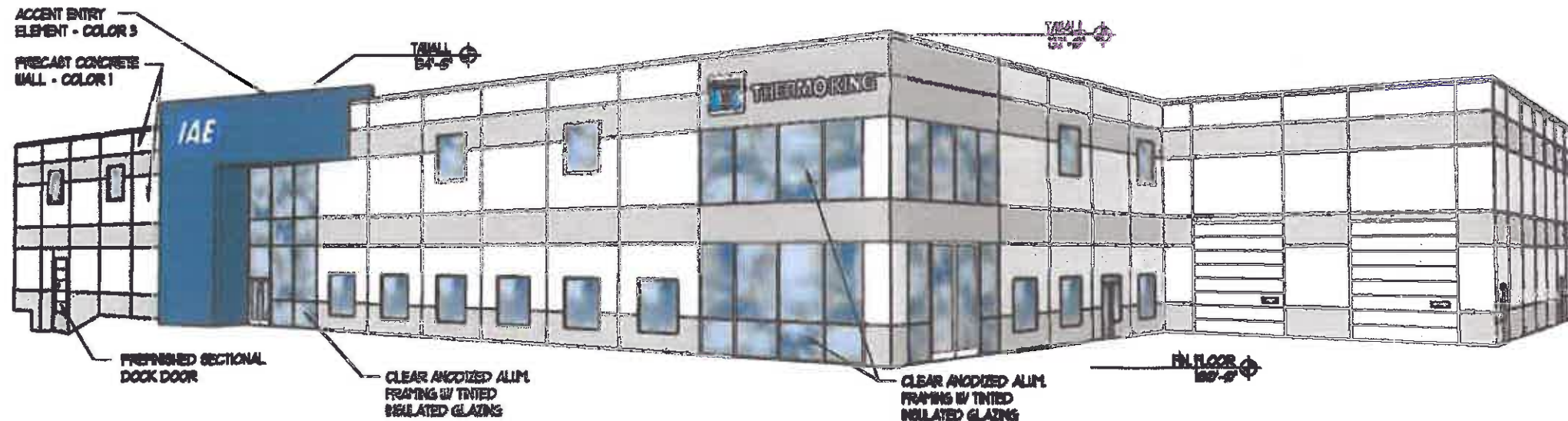

1 NORTHWEST VIEW  
A4.1 NTS



2 NORTHWEST AERIAL VIEW  
A4.1 NTS

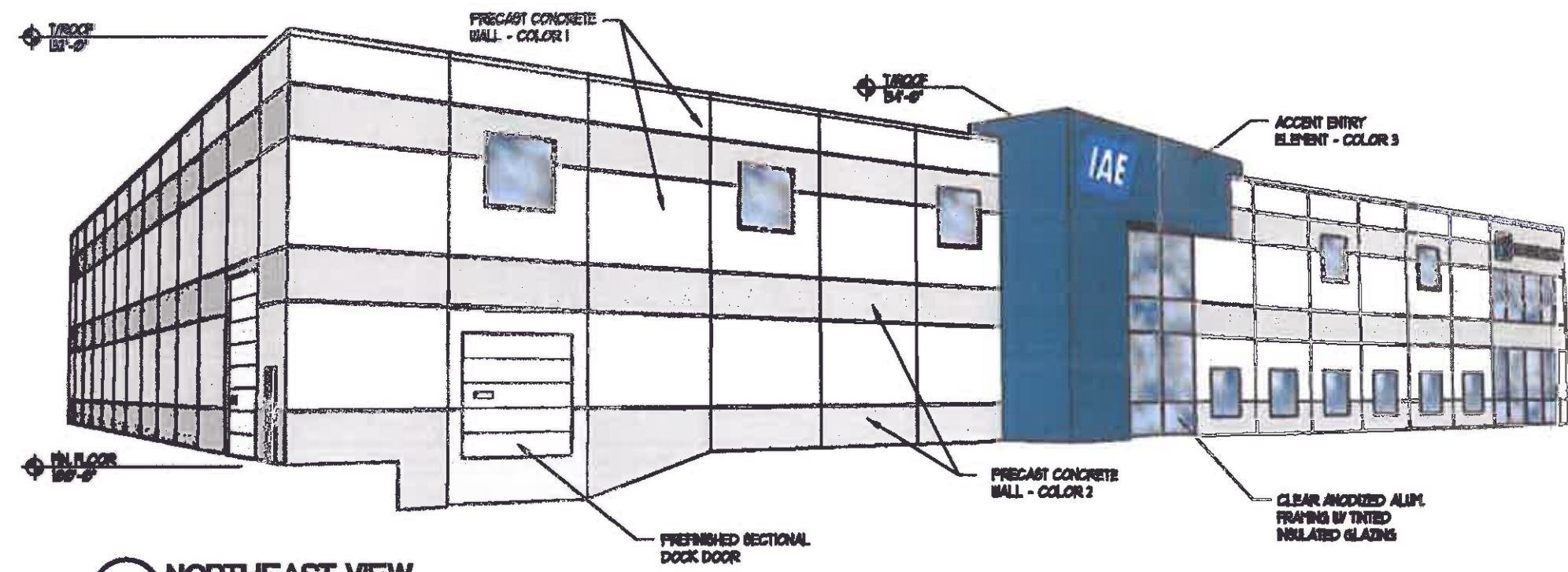

3 NORTHEAST VIEW  
A4.1 NTS



4 SOUTHEAST AERIAL VIEW  
A4.1 NTS

ILLINOIS AUTO CENTRAL THERMO KING  
Case Ave. 4 I-55, Darien, IL  
BUILDING VIEWS

2010 Lake Cook Road  
Suite 200  
Northbrook, Illinois 60062  
Ph: (847) 940-0300  
Fax: (847) 940-1045

Partners in Design  
ARCHITECTS



PROJECT NO:  
538.14.12  
DRAWN BY: CYR  
CHECKED BY: CTB  
DATE: 08.14.15  
SHEET NO:

A4.1

**Contractor:**  
Address  
Phone  
Fax  
e-mail

**Consultant:**  
Address  
Phone  
Fax  
e-mail

**Consultant:**  
Address  
Phone  
Fax  
e-mail

**Consultant:**  
Address  
Phone  
Fax  
e-mail

**Consultant:**  
Address  
Phone  
Fax  
e-mail

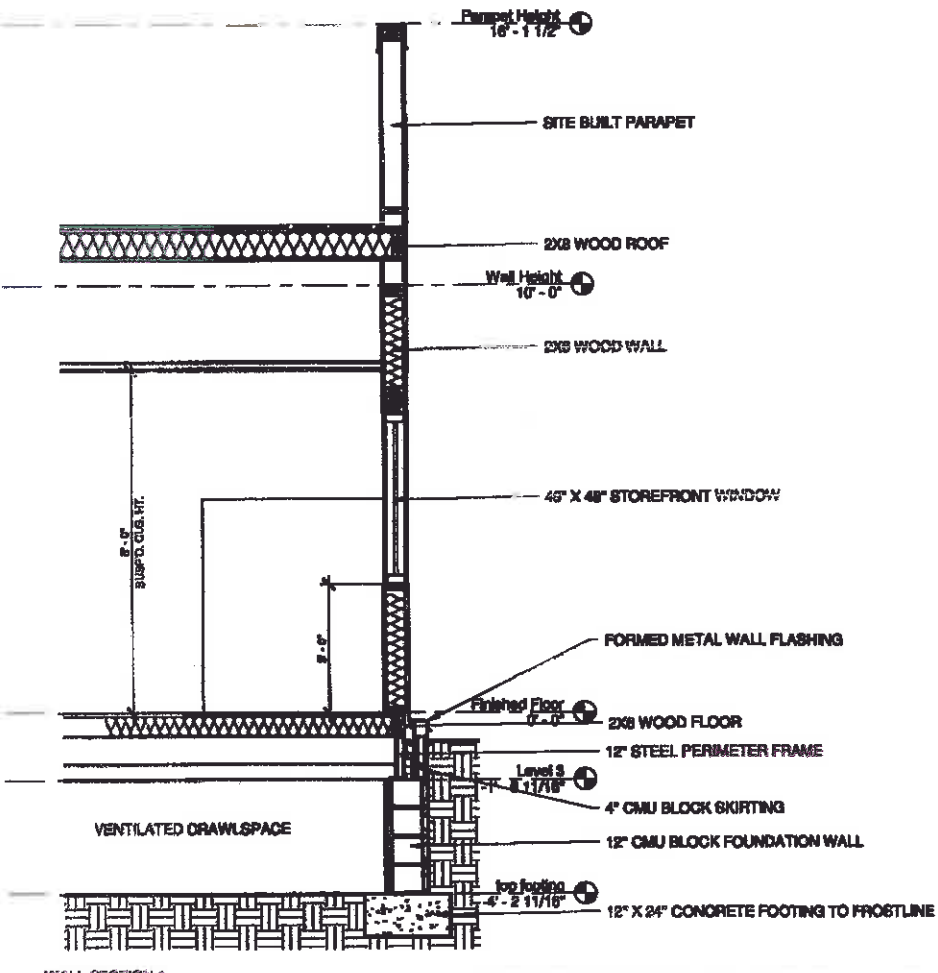

① WALL SECTION 1  
1/2" = 1'-0"

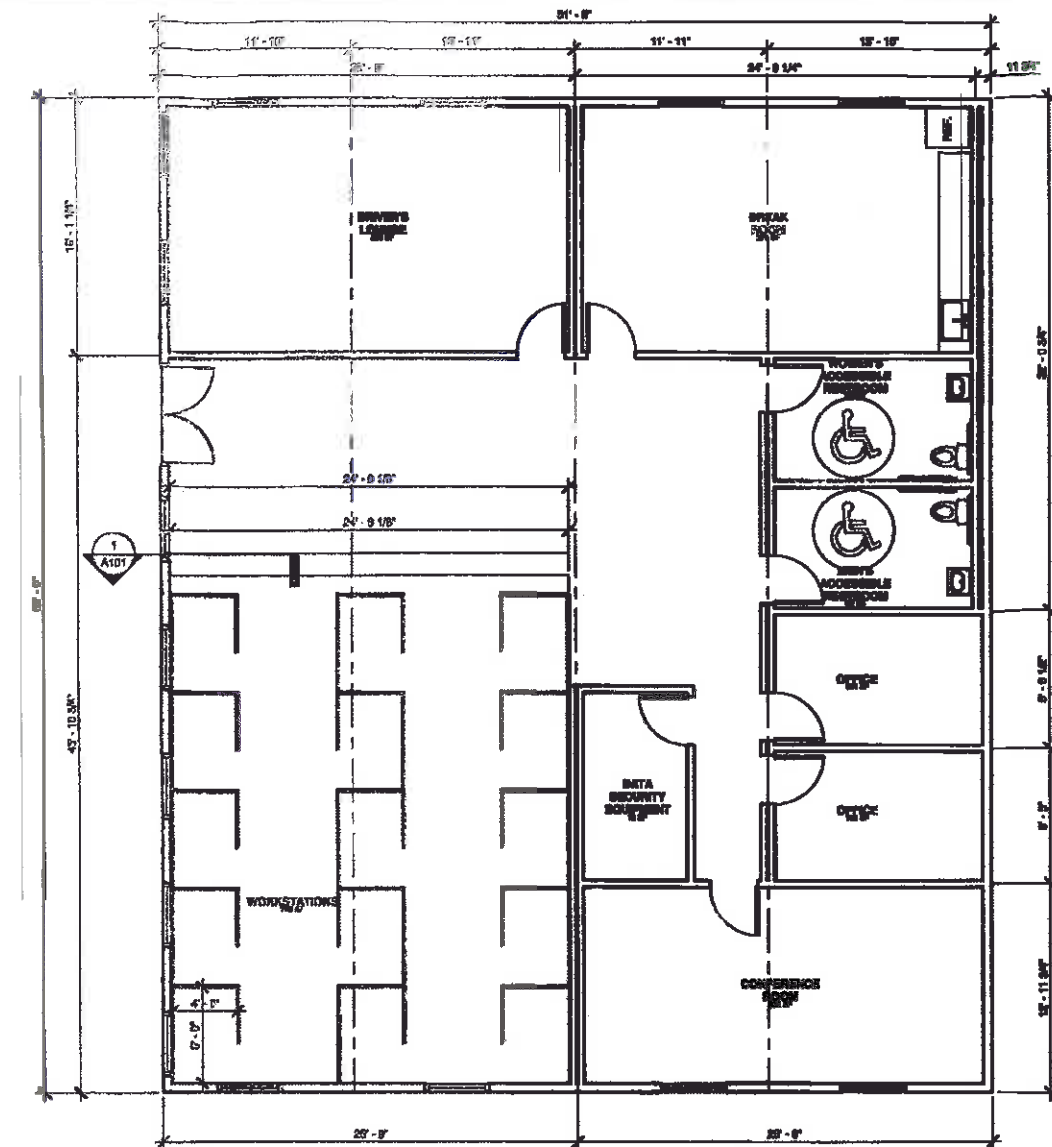

② PROPOSED FLOOR PLAN  
3/16" = 1'-0"

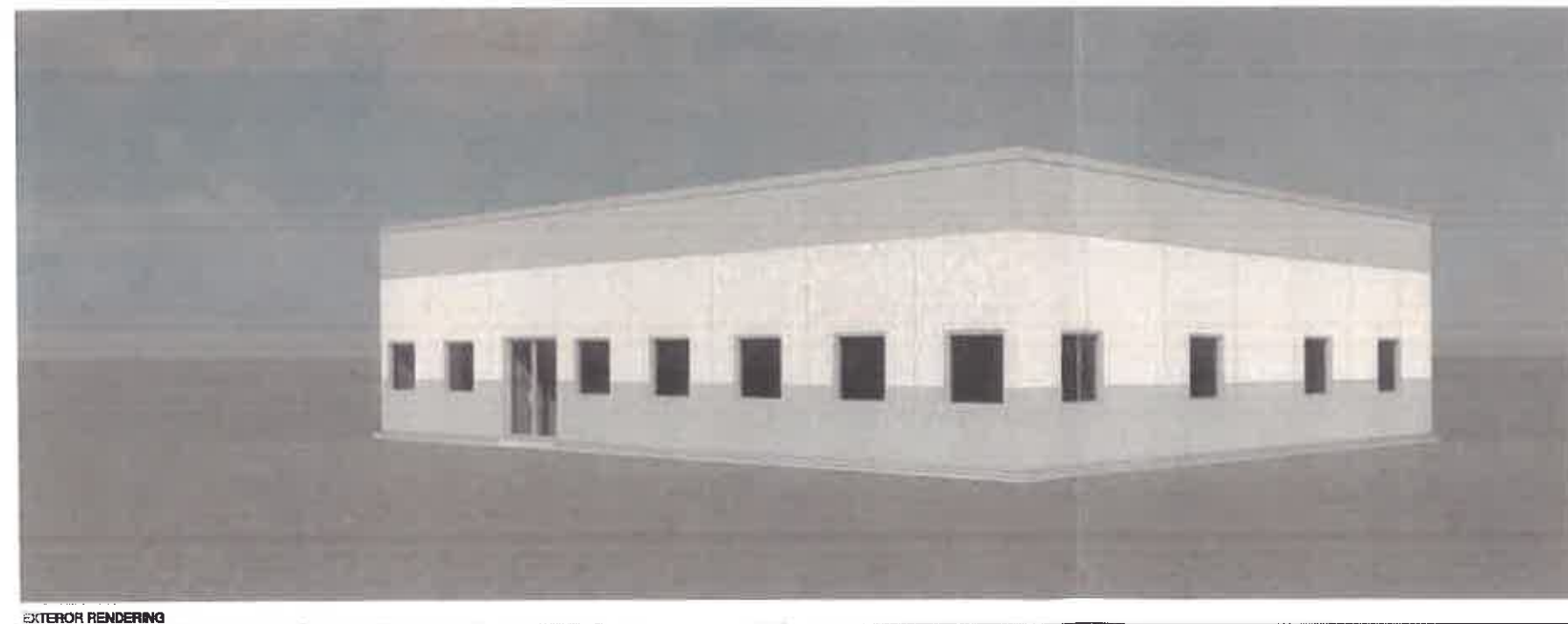

EXTERIOR RENDERING

**THIS PROPOSED FLOOR PLAN IS PRELIMINARY AND SUBJECT TO CHANGE / RECONFIGURATION BASED UPON ILLINOIS AUTO CENTRAL PROGRAMMING REQUIREMENTS**

No.	Description	Date

ILLINOIS AUTO  
CENTRAL THERMO KING

PROPOSED FLOOR PLAN  
EXTERIOR RENDERING &  
WALL SECTION

Project number: \_\_\_\_\_  
Date: **08/13/2015**  
Drawn by: **CHUCK KEEL**  
Checked by: \_\_\_\_\_

**A101**

Scale: As Indicated



**PROJECT:**

**IAE**

4750 S. Central  
Darien, IL

**CUSTOMER APPROVAL:**

DATE \_\_\_\_\_

AUTHORIZED SIGNATURE \_\_\_\_\_

REPRESENTATIVE \_\_\_\_\_

Lisa Staszak

DRAWN BY \_\_\_\_\_

Bill Marlow

DATE \_\_\_\_\_

8.14.15

SCALE \_\_\_\_\_

3/16" = 1'

SHEET NO. \_\_\_\_\_

1 of 1

WORK ORDER \_\_\_\_\_

73934

FILE NAME \_\_\_\_\_

IAE73934

**REVISIONS:**

1	_____
2	_____
3	_____
4	_____
5	_____
6	_____
7	_____
8	_____

This sign is intended to be installed in accordance with the requirements of Article 600 of the National Electrical Code and/or other applicable local codes. This includes proper grounding and bonding of the sign.

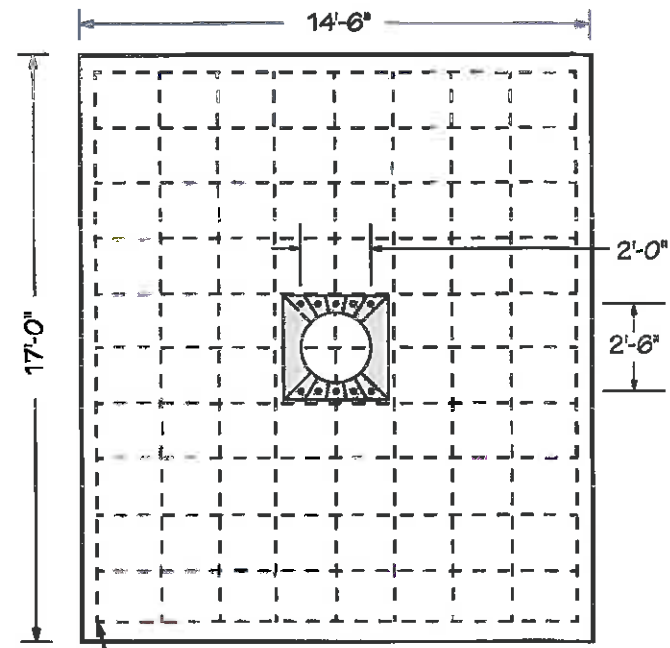
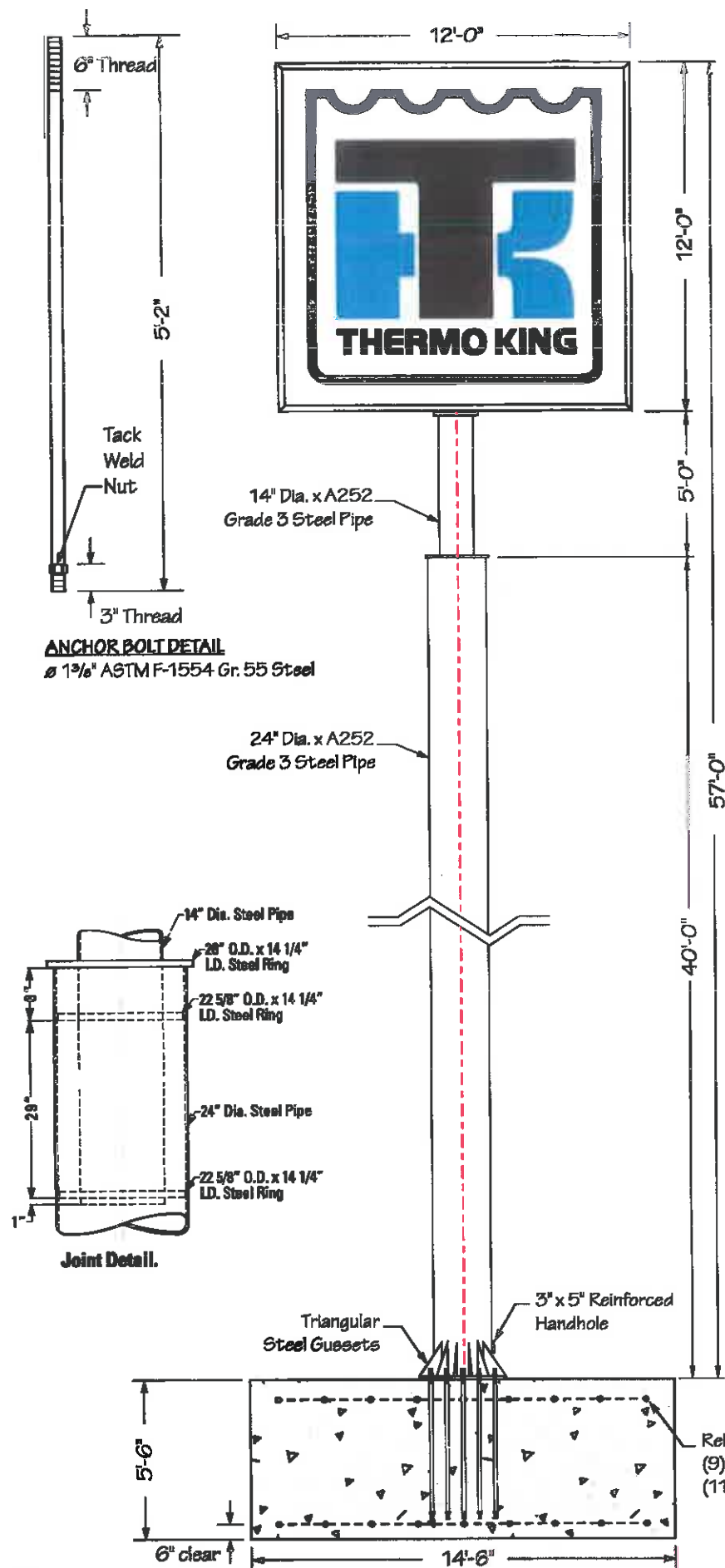

**PLANVIEW**  
50.2 Cu. Yds. Concrete

Rebar Mats Top & Bottom  
(9) #8 x 16'-0" Lg. (Total 18)  
(11) #8 x 13'-6" Lg. (Total 22)

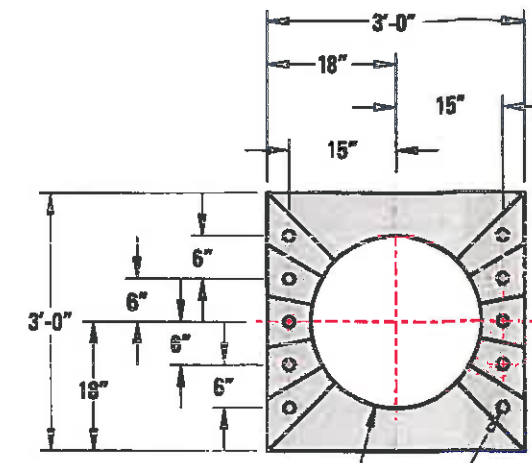

24 1/4" Dia. Cutout  
(10) 1 5/8" Dia. Bolt Holes  
**Baseplate with Triangular Steel Gussets**  
Material: A36 Steel Plate.

**(1) 12'-0" x 12'-0" x 2'-6" Double Face Illuminated Hi-Rise Pylon Sign**

**Cabinet:** Fabricated Aluminum Painted White - Satin Finish

**Faces:** White Panaflex Material

**Graphics:** Digitally Printed

**Illumination:** Fluorescent Lamps and Electronic Ballasts

**Power:** (2) 20Amp @ 120Volts Electrical Circuit Run to Site by Others

**Mounting:** Lower Section: 24" Dia. A252 Grade 3 Steel Pipe, 40'-0" long

Upper Section: 14" Dia. A252 Grade 3 Steel Pipe, 8'-0" long

Baseplate: 36" x 36" A36 Steel Plate with Steel Reinforcing Gussets

Sign Mounting Plate: 18" x 24" A36 Steel Plate

Anchor Bolts: (10) 1 3/8" Dia. x 62" long Anchor Bolt with 6" hook



This sign is built to UL Standards for operation in North America.

This Document is owned by, and the information contained in it is proprietary to, Parvin-Clauss Sign Company. By receipt hereof the holder agrees not to use the information, disclose it to any third party, nor reproduce this document without the prior written consent of Parvin-Clauss Sign Company. Holder also agrees to immediately return this document upon request of Parvin-Clauss Sign Company.

© Copyright 2015 by Parvin-Clauss Sign Co.





All base information & dimensions are approximate only. All layout to be verified in the field.

This plan is PRELIMINARY ONLY. It is subject to change pending final design and review with Owner.

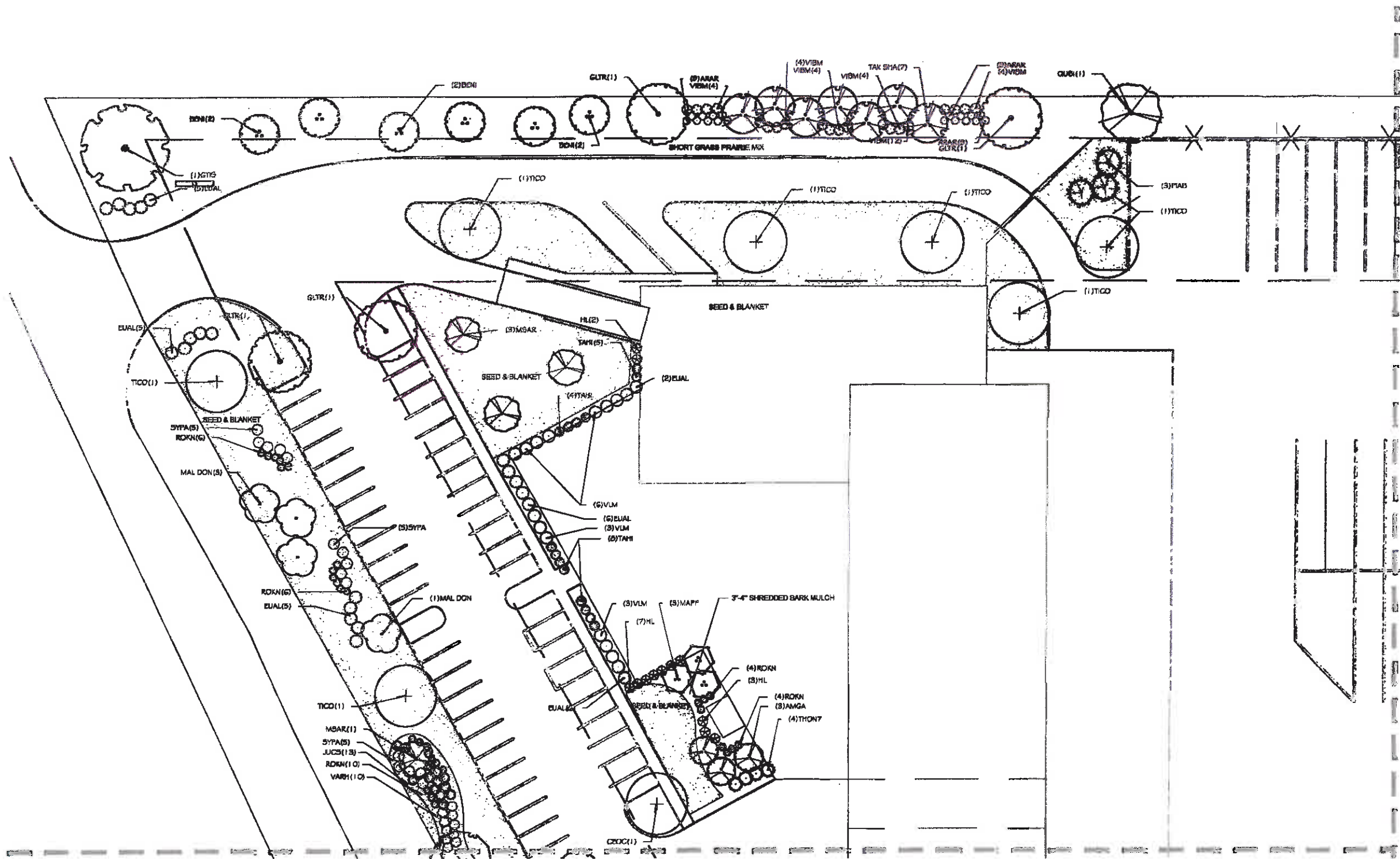

MATCH LINE 2 PLAN

SCALE: 1" = 20'-0"



**WINGREN LANDSCAPE**  
 6128 Walnut Ave.  
 Downers Grove, IL 60516  
 TEL 630.708.8180  
 www.wingrenlandscape.com

Copyright Wingren Landscape, all rights reserved. The design and any and all other content herein are the sole property of Wingren Landscape. Reproduction of the design or content without written consent of Wingren Landscape is prohibited.

**IAC Study**  
 Darien, IL

REVISIONS:

SHEET TITLE:  
**PRELIMINARY  
 LANDSCAPE  
 PLAN**

DATE: 8.08.15  
 JOB: P-  
 SCALE: 1"=20'  
 BY: JZ  
 SHEET **L2** OF 3

All base information & dimensions are approximate only. All layout to be verified in the field.

This plan is PRELIMINARY ONLY. It is subject to change pending final design and review with Owner.

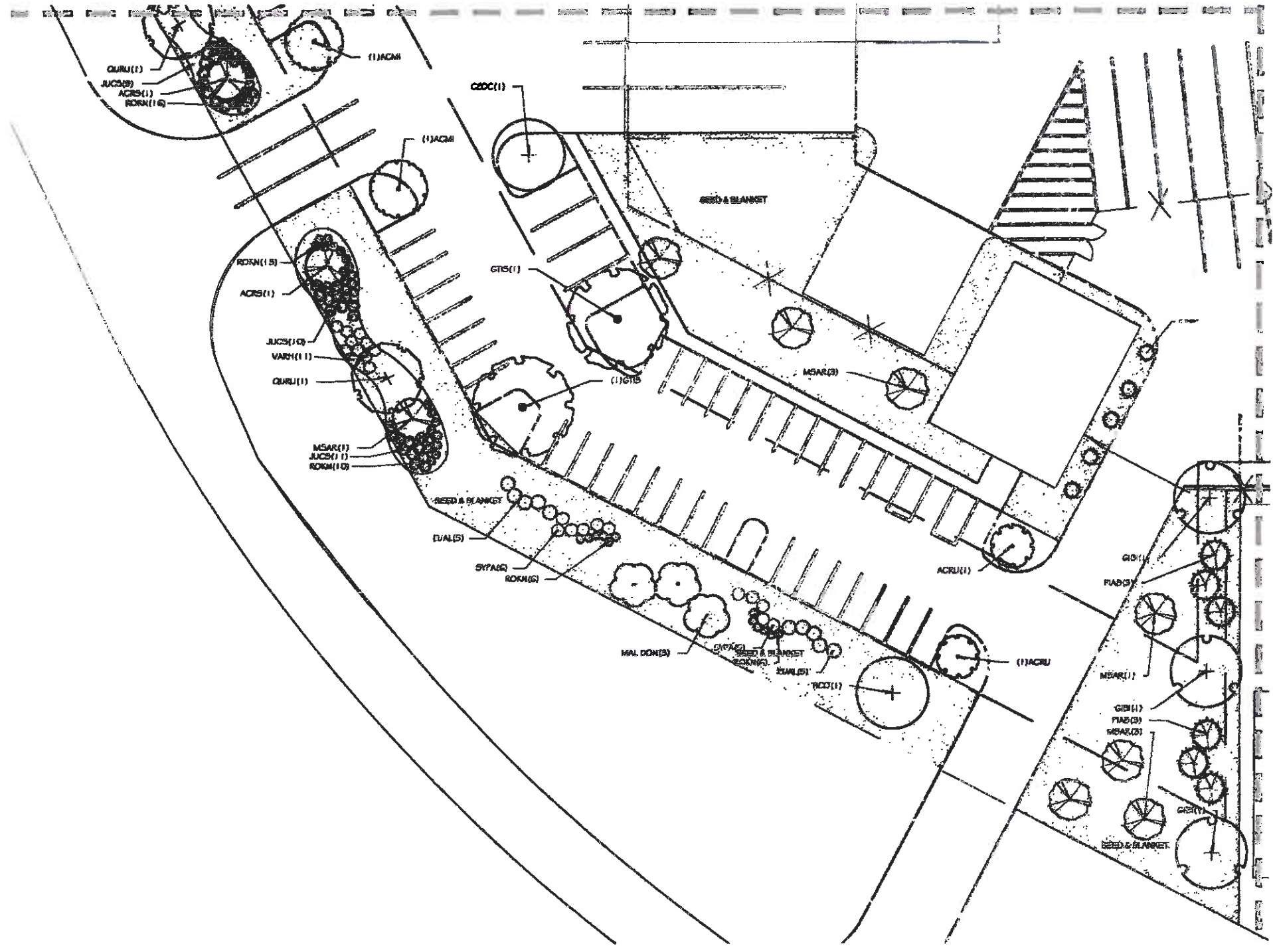

**PERIMETER YARD CALCULATIONS**

Planting	Quantity	Notes
QUARU	1	
JUCS	2	
ACRS	1	
RORNA	1	
ACRM	1	
GDC	1	
GDS	1	
MSAR	2	
RORNA	1	
ACRS	1	
JUCS	1	
VARD	1	
QUARU	1	
MSAR	1	
JUCS	1	
RORNA	1	
EUL	5	
SYTAG		
RORNA	5	
MAL DOME	5	
QUARU	1	
ACRU	1	
MSAR	1	
GDS	1	
PAD	5	
MSAR	5	
GDS	1	
PAD	5	
MSAR	5	
GDS	1	

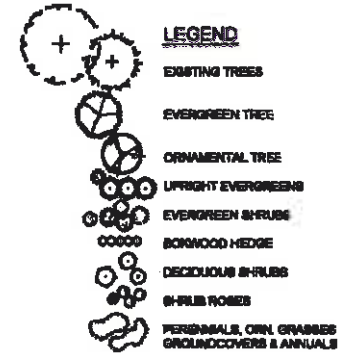

MATCH LINE 4 PLAN

SCALE: 1" = 20'-0"



**WINGREN LANDSCAPE**  
 6128 Walnut Ave.  
 Downers Grove, IL 60515  
 TEL: 630.789.5100  
 www.wingrenlandscape.com

Copyright Wingren Landscape. All rights reserved. The design and any and all ideas contained herein are the sole property of Wingren Landscape. Repeat action of the design or copying embodied herein in any form, in whole or in part, without the consent of Wingren Landscape is prohibited.

**IAC Study**  
 Darien, IL

REVISIONS:

SHEET TITLE:  
**PRELIMINARY  
 LANDSCAPE  
 PLAN**

DATE: 6.09.15  
 JOB: P-  
 SCALE: 1"=20'  
 BY: JZ  
 SHEET L3 OF 3



Lighting System	Lighting System	Lighting System	Lighting System
Code	Code	Code	Code
1	2	3	4
5	6	7	8
9	10	11	12
13	14	15	16
17	18	19	20
21	22	23	24
25	26	27	28
29	30	31	32
33	34	35	36
37	38	39	40
41	42	43	44
45	46	47	48
49	50	51	52
53	54	55	56
57	58	59	60
61	62	63	64
65	66	67	68
69	70	71	72
73	74	75	76
77	78	79	80
81	82	83	84
85	86	87	88
89	90	91	92
93	94	95	96
97	98	99	100

Lighting System	Lighting System	Lighting System	Lighting System
Code	Code	Code	Code
1	2	3	4
5	6	7	8
9	10	11	12
13	14	15	16
17	18	19	20
21	22	23	24
25	26	27	28
29	30	31	32
33	34	35	36
37	38	39	40
41	42	43	44
45	46	47	48
49	50	51	52
53	54	55	56
57	58	59	60
61	62	63	64
65	66	67	68
69	70	71	72
73	74	75	76
77	78	79	80
81	82	83	84
85	86	87	88
89	90	91	92
93	94	95	96
97	98	99	100

Lighting System	Lighting System	Lighting System	Lighting System
Code	Code	Code	Code
1	2	3	4
5	6	7	8
9	10	11	12
13	14	15	16
17	18	19	20
21	22	23	24
25	26	27	28
29	30	31	32
33	34	35	36
37	38	39	40
41	42	43	44
45	46	47	48
49	50	51	52
53	54	55	56
57	58	59	60
61	62	63	64
65	66	67	68
69	70	71	72
73	74	75	76
77	78	79	80
81	82	83	84
85	86	87	88
89	90	91	92
93	94	95	96
97	98	99	100

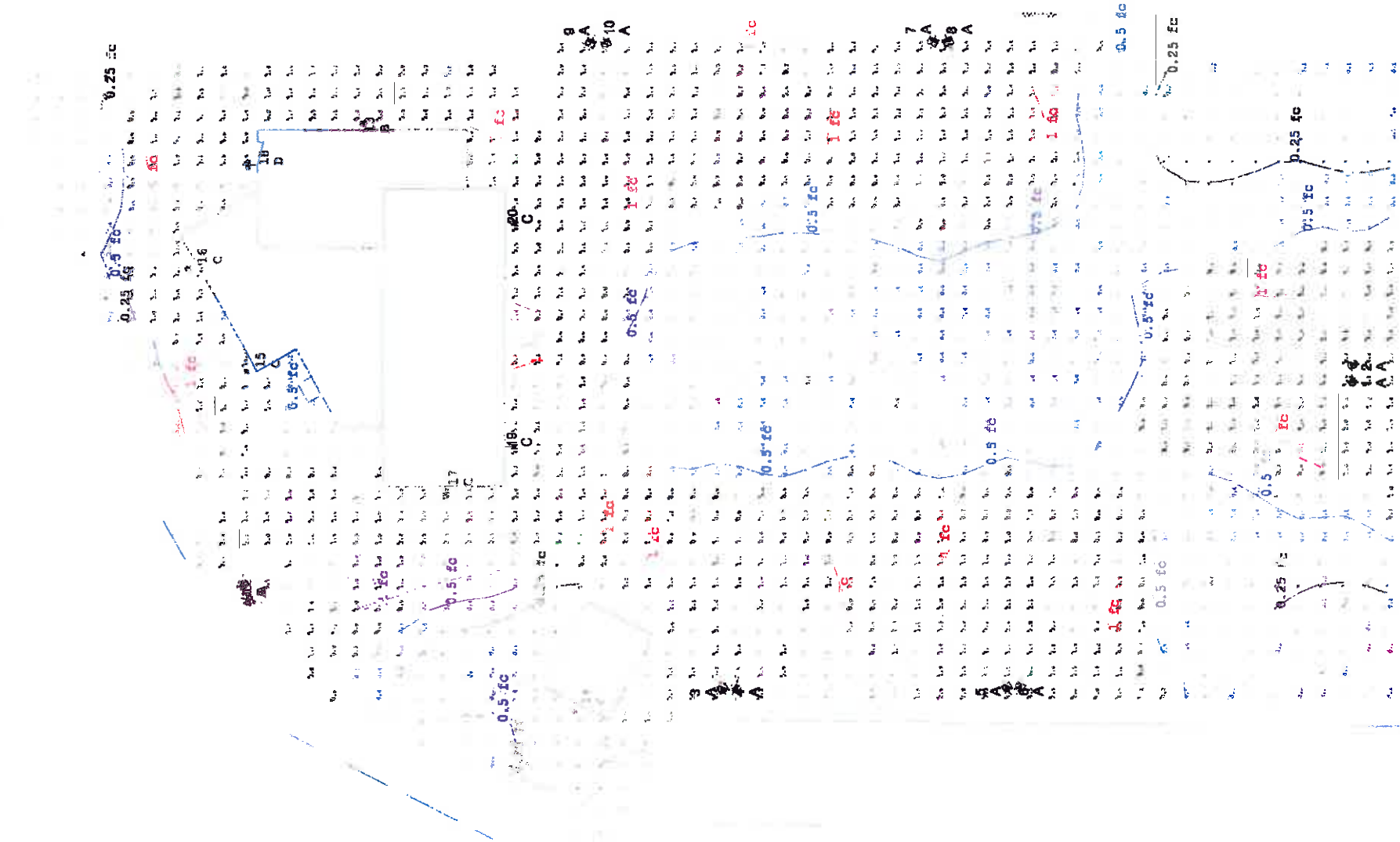

Illinois Auto Central Thermo-King  
 Danem, IL  
 Site Lighting/Photometric Plan

Scale 1"=30'-0"  
 6/29/2015

**PRELIMINARY SITE IMPROVEMENT PLANS**  
for  
**ILLINOIS AUTO CENTRAL**  
**THERMO KING**  
DARIEN, ILLINOIS

**PROJECT NO:8552**

**CONTRACTOR**  
PRINCIPLE CONSTRUCTION CORP.  
9450 WEST BRYN MAWR, SUITE 765  
ROSEMONT, IL 60018  
PH: 847-615-1515

**ARCHITECT**  
PARTNERS IN DESIGN ARCHITECTS  
2610 LAKE COOK ROAD, SUITE 280  
RIVERSWOOD, ILLINOIS 60015  
PH: 847-940-0300

**CALL JULIE 1-800-892-0123**  
WITH THE FOLLOWING:  
COUNTY DUPAGE  
CITY, TOWNSHIP DARIEN  
SEC. & 1/4 SEC. NO. SW 1/4 SEC 34, T36N, R11E  
**48 HOURS BEFORE YOU DIG.**  
EXCLUDING SAT., SUN. & HOLIDAYS

INDEX		
SHEET #	SHEET ID	SHEET DESCRIPTION
1	CI	COVER SHEET
2	EC	EXISTING CONDITIONS
3	P-GM	GEOMETRIC PLAN
4	P-GR	PRELIMINARY GRADING
5	P-UT	PRELIMINARY UTILITY PLAN

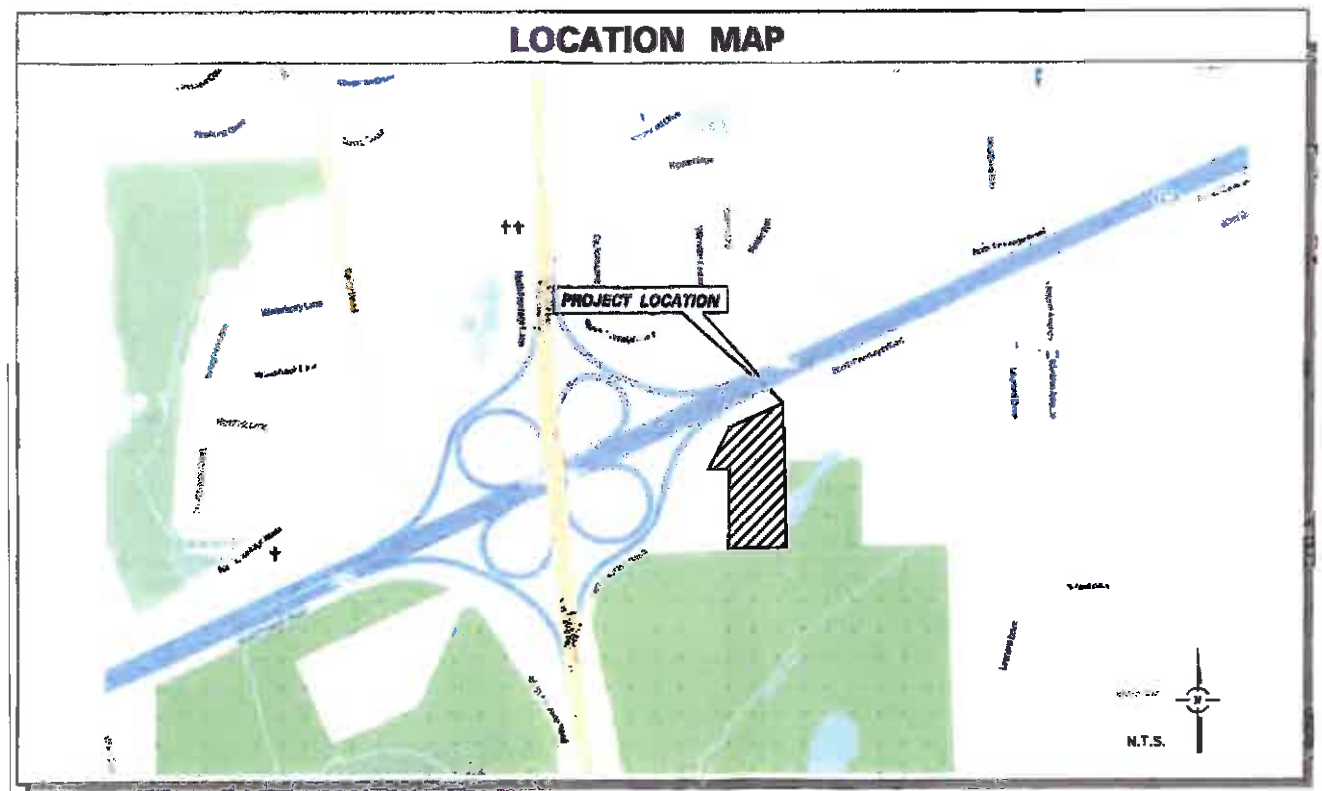

REVISIONS			
ORIGINAL PLAN DATE: JUNE 25, 2015			
#	SHEET #	REMARKS	DATE

ENGINEER \_\_\_\_\_ DATE \_\_\_\_\_  
BRETT M. DUFFY, P.E.  
ILLINOIS REGISTRATION NO. 062-053198  
EXPIRATION DATE: 11/30/2015  
PROFESSIONAL DESIGN FIRM NO. 084-001157  
EXPIRATION DATE: 04/30/2017  
THESE PLANS OR ANY PART THEREOF SHALL BE VOID WITHOUT THE SIGNATURE, SEAL, AND EXPIRATION DATE OF SEAL OF THE ENGINEER

**ILLINOIS AUTO CENTRAL**  
**THERMO KING**  
DARIEN, ILLINOIS

9575 W. Higgins Road, Suite 700, Rosemont, Illinois 60018  
Phone: (847) 696-4060 Fax: (847) 696-4065



FILENAME:  
8552-TITLE.DWG

DATE:  
08/28/15

JOB NO.  
8552

SHEET  
1 OF 5

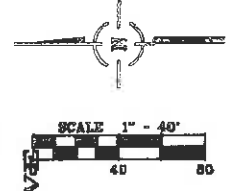
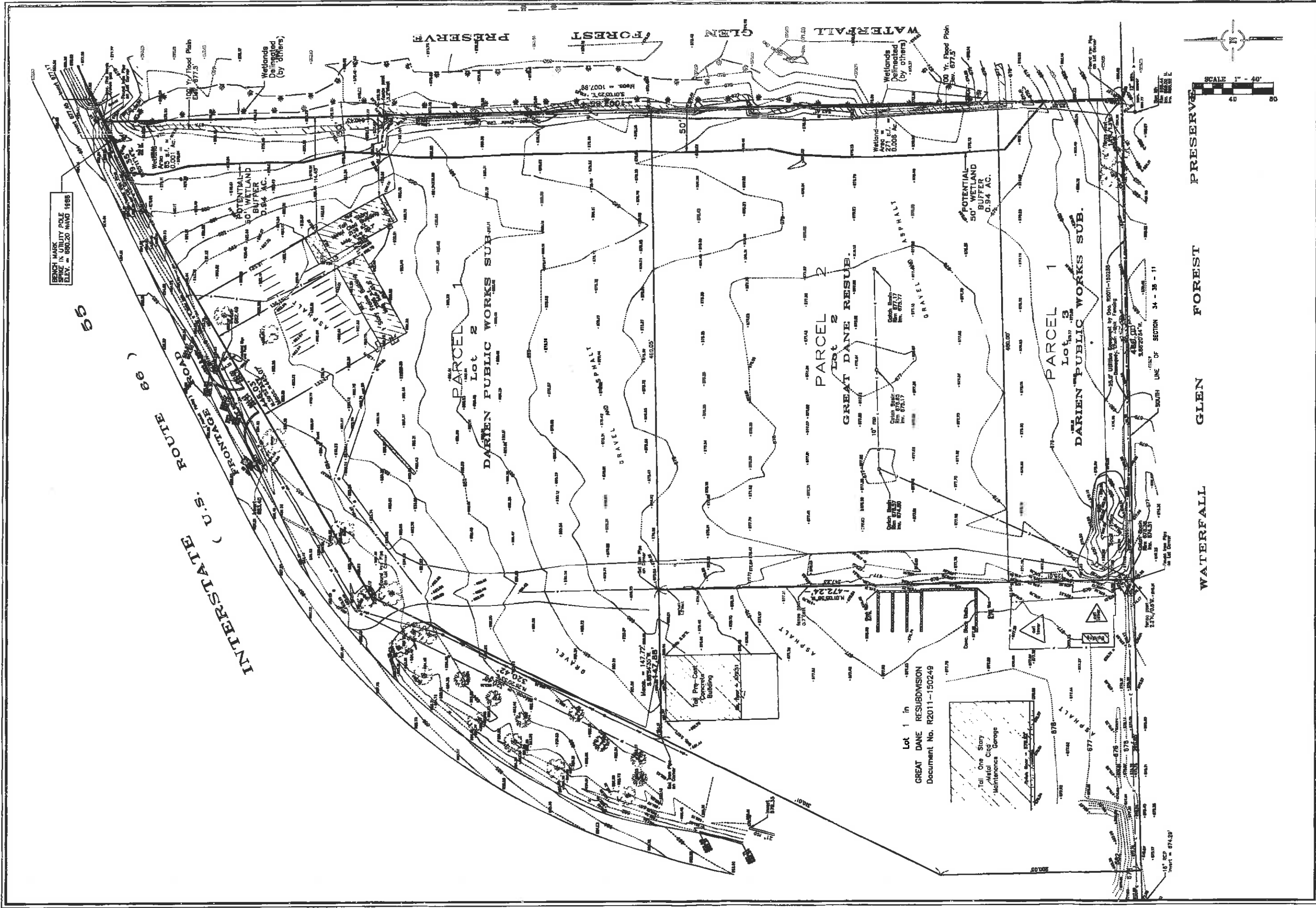

<p>EXISTING CONDITIONS</p> <p><b>ILLINOIS AUTO CENTRAL</b></p> <p><b>THERMO KING</b></p> <p>DARRIEN, ILLINOIS</p>		<p>NO. DATE REMARKS</p>
<p>SPADCO, INC.</p> <p>FILENAME: 8552P-FTOLDGN</p> <p>DATE: 06/25/15</p> <p>JOB NO. 8552</p> <p>SHEET</p>		<p>NO. DATE REMARKS</p>
<p>1975 W. Higgins Road, Suite 700, Bloomington, Illinois 61718 Phone: (847) 664-6000 Fax: (847) 894-4008</p>		<p>NO. DATE REMARKS</p>
<p><b>EC</b></p> <p>2 OF 5</p>		<p>NO. DATE REMARKS</p>

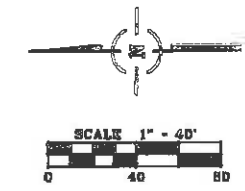

- LEGEND**
- HEAVY DUTY PAVEMENT  
(1.5\"/>
  - PASSENGER VEHICLE DRIVE AISLES  
(1.5\"/>
  - PASSENGER VEHICLE PARKING AISLES  
(1.5\"/>
  - COMPACTED GRAVEL
  - CONCRETE PAVEMENT
  - CONCRETE SIDEWALK
  - 9-6.12 CURB & GUTTER
  - DEPRESSED CURB & GUTTER
  - CHAIN LINK FENCE
  - SILT FENCE
  - 1** STOP SIGN R1-1 30\"/>

- NOTES:**
1. ALL CONSTRUCTION CURB & GUTTER SHALL BE 9-6.12.
  2. ALL DIMENSIONS ARE FROM BACK OF CURB, UNLESS FOUNDATION OR PROPERTY LINE UNLESS OTHERWISE NOTED.
  3. ACTUAL BUILDING FOOTPRINT MAY VARY, SEE FINAL ARCHITECTURAL PLANS.

**IMPERVIOUS COVERAGE SUMMARY:**  
 EXISTING IMPERVIOUS COVERAGE = 388,971 S.F.  
 PROPOSED IMPERVIOUS COVERAGE = 388,206 S.F.  
 INCREASE IN IMPERVIOUS COVERAGE = 1,734 S.F.  
 -PER ARTICLE 8, SECTION 15-63A.1 OF DUPAGE COUNTY  
 COUNTYWIDE STORMWATER & FLOOD PLAIN  
 ORDINANCE, NO PCBMPs ARE REQUIRED SINCE  
 THE INCREASE IN IMPERVIOUS COVERAGE IS LESS  
 THAN 2,500 S.F.

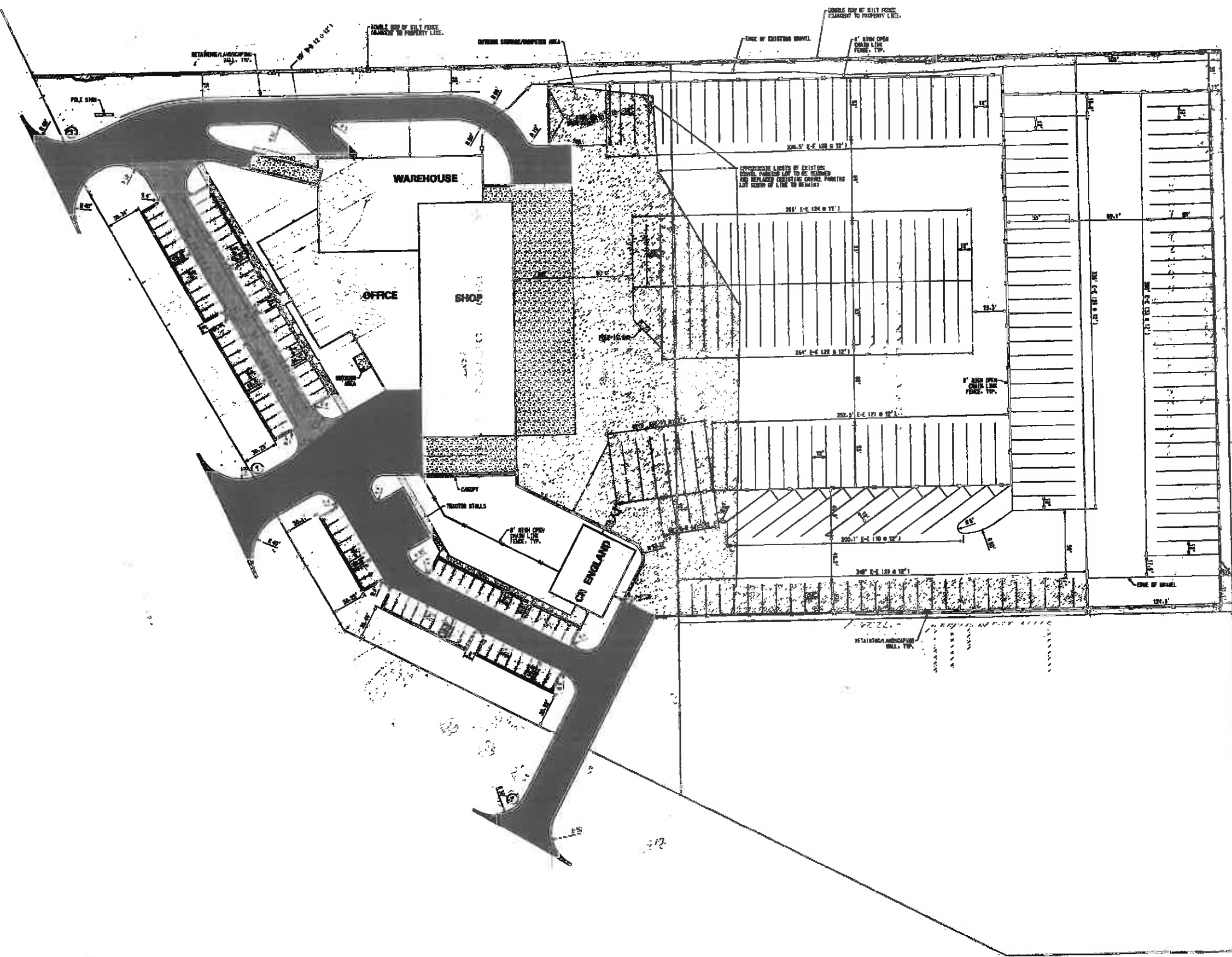

	NO. DATE REMARKS
	NO. DATE REMARKS
<b>PRELIMINARY GEOMETRIC PLAN</b> <b>ILLINOIS AUTO CENTRAL</b> <b>THERMO KING</b> DANIEL, ILLINOIS	
CONSULTING ENGINEER <b>SPACECO INC.</b> 9275 W. Higgins Road, Suite 700, Rosemont, Illinois 60018 Phone: (847) 664-6000 Fax: (847) 664-6005	
FILENAME: B552P-GILDON	
DATE: 08/25/15	
JOB NO. B552	
SHEET <b>P-GM</b> 3 OF 5	



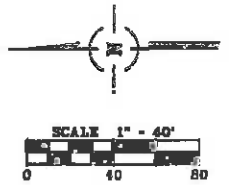
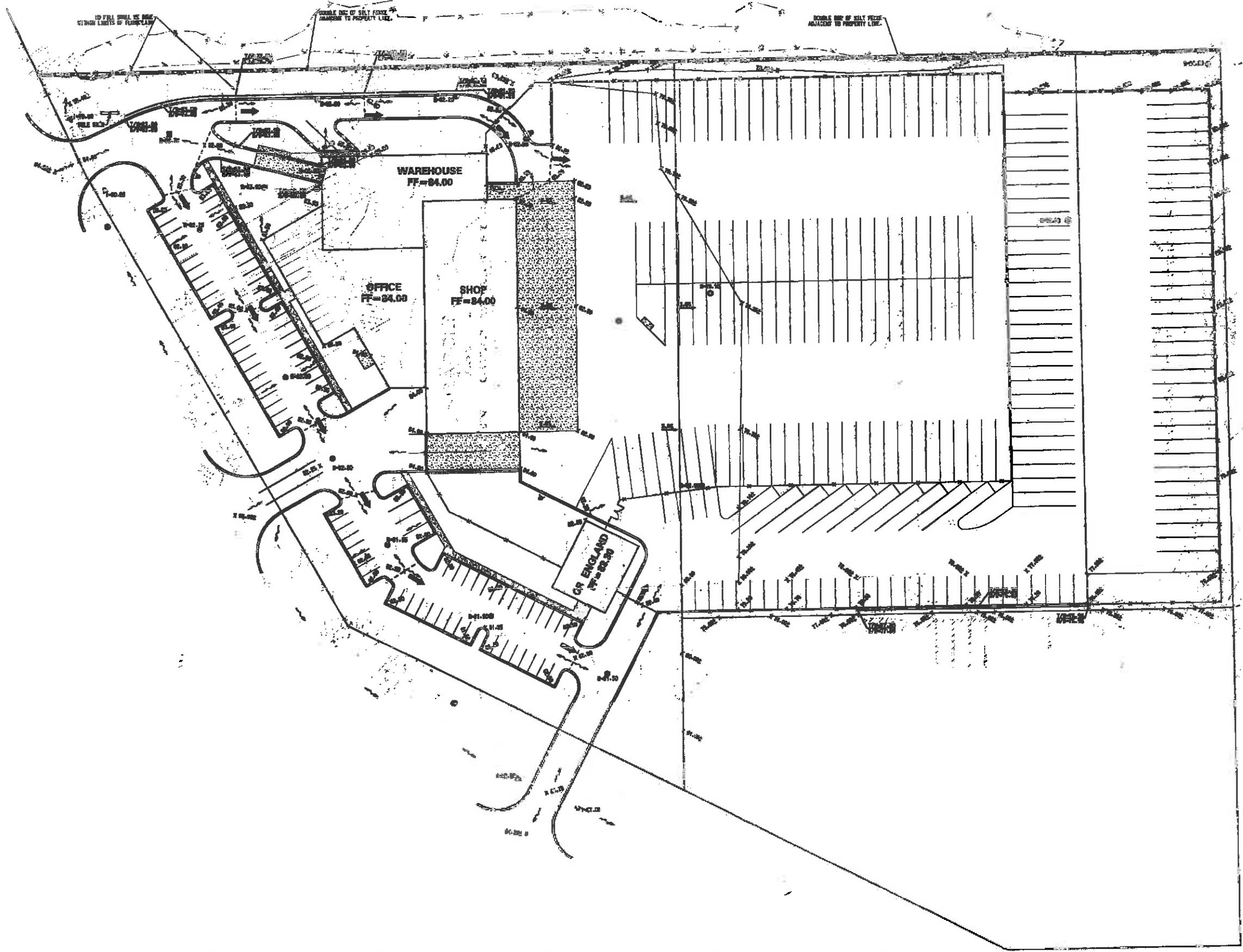

- LEGEND**
- FF FINISHED FLOOR
  - LOCAL DRAINAGE
  - 100-YEAR OVERLAND FLOW ROUTE
  - LOCAL DRAINAGE DIVIDE
  - TOP OF CURB  
EDGE OF PAVEMENT
  - FINISHED SURFACE ELEVATION
  - MEET EXISTING GRADE
  - TOP OF WALL  
BOTTOM OF WALL
  - FIRE HYDRANT
  - SANITARY MANHOLE
  - INLET
  - MANHOLE
  - CATCH BASIN
  - PRESSURE CONNECTION
  - VALVE VAULT
  - CURB & GUTTER (3-6.12)

- NOTES:**
1. ADD 68.00 TO ALL ELEVATIONS SHOWN AS XX.XX
  2. ALL CURB AND GUTTER IS 6.12 UNLESS NOTED OTHERWISE.
  3. ALL SPOT GRADES ALONG CURB LINE ARE EDGE OF PAVEMENT UNLESS NOTED OTHERWISE.

NO. DATE	REMARKS
<b>PRELIMINARY GRADING PLAN</b> <b>ILLINOIS AUTO CENTRAL</b> <b>THERMO KING</b> DARIEN, ILLINOIS	
9521 W. 116th St. Berk, Suite 370, Rosemary, Mo. 64078 Phone: (847) 892-4000 Fax: (847) 894-4005	
<b>SPARECO INC.</b>	
FILE NAME: 8592P-GR.DGN	
DATE: 06/25/15	
JOB NO. 8592	
SHEET <b>P-GR</b> 4 OF 5	



CONNECT TO EXISTING SANITARY SAN. VERIFY LOCATION OF STW PRIOR TO CONSTRUCTION. IF STW IS OPPOSITE AND NOT CORRECTLY IN AN EASEMENT, A TEMPORARY CONSTRUCTION EASEMENT WILL NEED TO BE PROVIDED WITH PERMITS 1-40-03 2

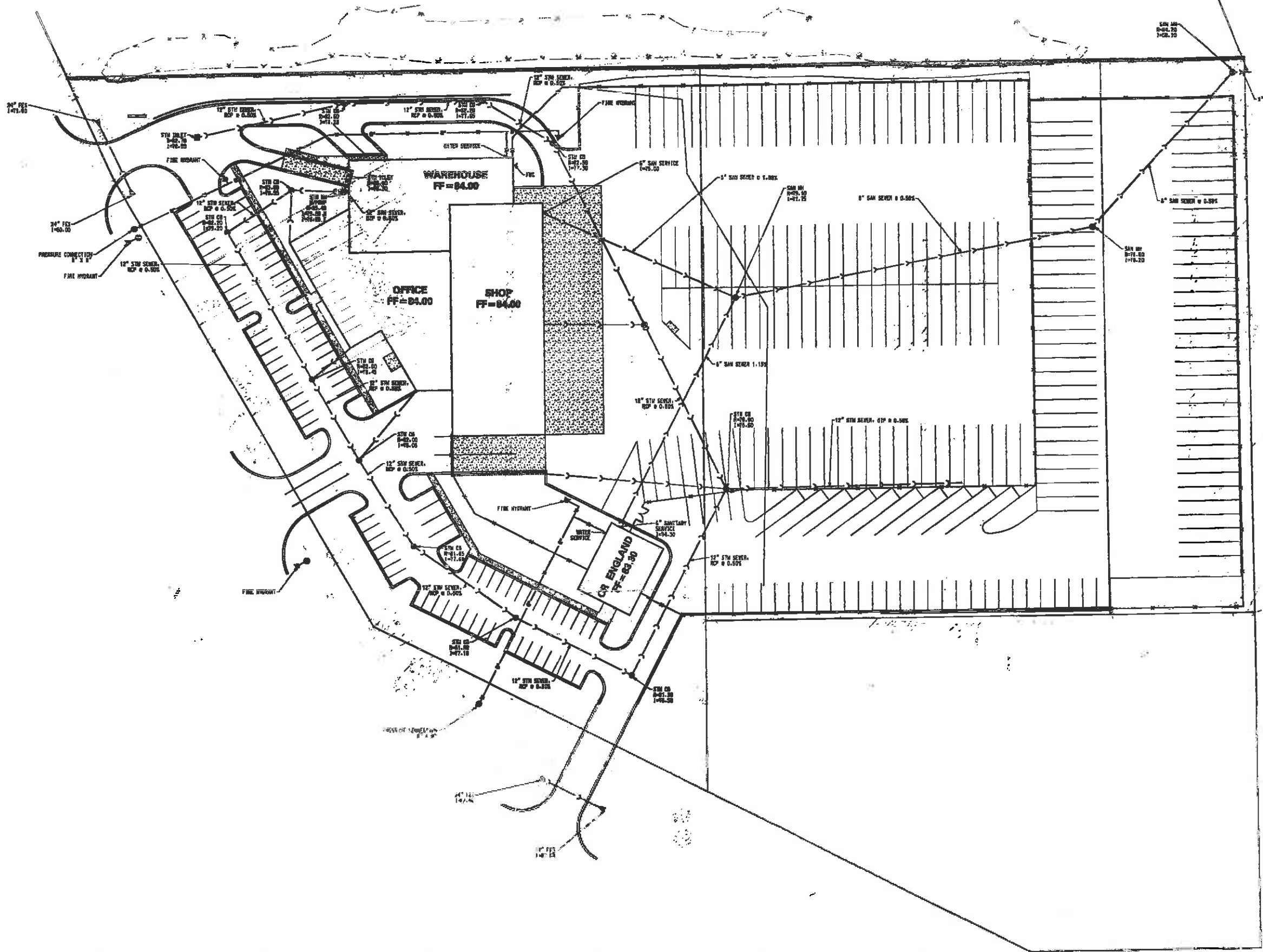
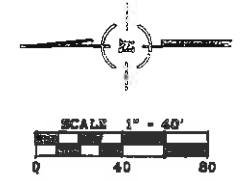

- LEGEND**
- FF FINISHED FLOOR
  - STW STORM DRAIN
  - WATERMAIN
  - SANITARY DRAIN
  - FIRE HYDRANT
  - SANITARY MANHOLE
  - INLET
  - MANHOLE
  - CATCH BASIN
  - PRESSURE CONNECTION
  - VALVE VAULT

**NOTES:**  
ADD 600.00 TO ALL ELEVATIONS SHOWN AS XXXX

NO.	DATE	REMARKS

NO.	DATE	REMARKS

**PRELIMINARY UTILITY PLAN  
ILLINOIS AUTO CENTRAL  
THERMO KING  
DARIEN, ILLINOIS**

9973 W. Higgins Road, Suite 702  
Rosemont, Illinois 60018  
Phone: (847) 684-4000 Fax: (847) 684-4088



FILENAME:  
8552P-UT.DGN  
DATE:  
05/23/18  
JOB NO.  
8552  
SHEET  
P-UT  
5 OF 6

**AGENDA MEMO**  
**Municipal Services Committee Meeting**  
**August 24, 2015**

**ISSUE STATEMENT**

A resolution to enter into a contract agreement with Concrete Solutions International LLC. for the labor, material and installation of a Concrete Floor Finish for the Public Works Facility Garage in the amount of \$38,500.

**BACKGROUND**

The FY15/16 Budget includes funds to refurbish the garage floor at the Public Works facility located at 1041 South Frontage Road. The floor requires maintenance due to years of wear and tear from salt, water, and traffic thus causing spalling and cracks. The current conditions also make it difficult to move equipment and shop tools across the floor.

The garage floor refinishing project will allow the floor to be reconditioned to a uniform surface and allow ease of cleaning. The scope of the work includes the following:

- Shot Blasting
- Polymer Filling/Leveling Agent
- Epoxy Coating

Bid invitations and a legal notice were sent out and one sealed responsive bid was opened on August 13, 2015. Concrete Solutions provided a bid in the amount of \$40,155, see attached bid sheet labeled as Attachment A. The FY15/16 Budget allocated \$38,500 and the bid is over budget by \$3,000. Staff had reached out to them requesting consideration to negotiate the pricing to \$38,500. Concrete Solutions agreed to the negotiated price; see attached e-mail labeled as Attachment B. The additional bid from Drake Specialized Services was non-responsive and rejected.

The proposed expenditure would be expended from the following account:

ACCOUNT NUMBER	ACCOUNT DESCRIPTION	FY 15/16 BUDGET	PROPOSED EXPENDITURE
01-30-4223	PW GARAGE COATING	\$19,250.00	\$19,250.00
02-50-4223	PW GARAGE COATING	\$19,250.00	\$19,250.00
TOTALS		\$38,500.00	\$38,500.00

**STAFF RECOMMENDATION**

Staff recommends approval of this resolution, accepting a proposal from Concrete Solutions International LLC. for the labor, material and installation of a concrete floor finish for the Public Works Facility Garage in the amount of \$38,500.

**ALTERNATE CONSIDERATION**

As directed by the Municipal Services Committee.

**DECISION MODE**

This item will be placed on the September 8, 2015 City Council agenda for formal approval.

**CITY OF DARIEN PUBLIC WORKS  
1702 PLAINFIELD ROAD  
DARIEN, IL 60561**

**SEALED BID: Public Works Garage Floor Epoxy Coating Project**

**OPENING DATE/TIME: August 13, 2015 @ 11:00 a.m.**

				Concrete Solutions Int LLC 1983 Johns Drive Glenview, IL 60025		Drake Specialized Services, Inc P.O. Box 331 Fox Lake, IL 60020			
ITEM	DESCRIPTION	Units (Square Feet)	Unit Price						
1	Provide Equipment, Labor and Material to Prepare Existing Concrete Floor Garage for an Epoxy Finish as per the Contract Specification	8,800	\$ 4.56	\$ 40,155.00			Non-responsive; Rejected bid.		
<b>Total</b>				\$ 40,155.00					

Lisa Klemm

---

**From:** Dan Gombac  
**Sent:** Monday, August 17, 2015 1:33 PM  
**To:** mike@csifloor.com  
**Cc:** Bryon Vana; Lisa Klemm  
**Subject:** RE: Garage Floor Bid-Negotiated pricing

Thank you for your consideration.

*Daniel Gombac*  
 Director of Municipal Services  
 630-353-8106

To receive important information from the City of Darien sign up for our electronic newsletter:

***DARIEN DIRECT CONNECT***

Follow the link below and subscribing is simple!

<http://www.darien.il.us/Departments/Administration/CityNews.html>

---

**From:** [mike@csifloor.com](mailto:mike@csifloor.com) [<mailto:mike@csifloor.com>]  
**Sent:** Monday, August 17, 2015 12:10 PM  
**To:** Dan Gombac  
**Subject:** Re: Garage Floor Bid-Negotiated pricing

Dan

It is ok, We will do the job for \$38,500.

Thanks  
 Mike Vaknin  
 Concrete Solutions International LLC  
 1983 Johns Drive  
 Glenview, IL 60025  
 773-447-0786  
 847-962-8610  
[Mike@csifloor.com](mailto:Mike@csifloor.com)  
[www.concretesolutionsinternational.com](http://www.concretesolutionsinternational.com)

On Aug 17, 2015, at 12:03 PM, Dan Gombac <[dgombac@darienil.gov](mailto:dgombac@darienil.gov)> wrote:

Good morning Mike:

Per our earlier telephone conversation, Staff had informed you that Concrete Solutions was the only responsive bid in the amount of \$40,155. The City's budget allocated \$38,500 for the project and per our

conversation CSI has agreed to complete the work for \$38,500. Please acknowledge this e-mail to confirm the pricing at \$38,500.

Sincerely,

*Daniel Gombac*

*Director of Municipal Services*

*630-353-8106*

To receive important information from the City of Darien  
sign up for our electronic newsletter:

***DARIEN DIRECT CONNECT***

Follow the link below and subscribing is simple!

[http://www.darien.il.us/Departments/Administratio  
n/CityNews.html](http://www.darien.il.us/Departments/Administratio<br/>n/CityNews.html)

RESOLUTION NO. \_\_\_\_\_

**A RESOLUTION TO ENTER INTO A CONTRACT AGREEMENT WITH  
CONCRETE FLOOR FINISH FOR THE PUBLIC WORKS FACILITY GARAGE IN  
THE AMOUNT OF \$38,500.00**

**BE IT RESOLVED BY THE CITY COUNCIL OF THE CITY OF DARIEN, DU PAGE  
COUNTY, ILLINOIS, as follows:**

**SECTION 1:** The City Council of the City of Darien hereby approves a resolution to enter into a contract agreement with Concrete Floor Finish for the Public Works Facility Garage in the amount of \$38,500.00, a copy of which is attached hereto as "Exhibit A" and is by this reference expressly incorporated herein.

**SECTION 2:** This Resolution shall be in full force and effect from and after its passage and approval as provided by law.

**PASSED BY THE CITY COUNCIL OF THE CITY OF DARIEN, DU PAGE COUNTY,  
ILLINOIS, this 8th day of September, 2015.**

AYES: \_\_\_\_\_

NAYS: \_\_\_\_\_

ABSENT: \_\_\_\_\_

**APPROVED BY THE MAYOR OF THE CITY OF DARIEN, DU PAGE COUNTY,  
ILLINOIS, this 8th day of September, 2015.**

\_\_\_\_\_  
KATHLEEN MOESLE WEAVER, MAYOR

ATTEST:

\_\_\_\_\_  
JOANNE E. RAGONA, CITY CLERK

APPROVED AS TO FORM:

\_\_\_\_\_  
CITY ATTORNEY

**SECTION II**

**BIDDER SUMMARY SHEET**

**2015 Public Works Garage Floor Epoxy Coating Project**

Firm Name: concrete Solutions Int LLC

Address: 1983 Johns Drive

City, State, Zip Code: Glenview IL 60025

Contact Person: Michael Vayenin

FEIN #: 46-4604467

Phone: (773) 447 0786 Fax: (847) 600-4039

Mobile: 773) 447-0786

E-mail Address: MIKE @ CSI Floor. com

**RECEIPT OF ADDENDA:** The receipt of the following addenda is hereby acknowledged:

Addendum No. \_\_\_\_\_, Dated \_\_\_\_\_

Addendum No. \_\_\_\_\_, Dated \_\_\_\_\_

**CITY OF DARIEN**  
**2015 Public Works Garage Floor Epoxy Coating Project**

The undersigned "Contractor" offers to provide to the City of Darien, an Illinois Municipal Corporation, Concrete Replacement Services conforming to the specifications attached hereto, with such exceptions or modifications as herewith set forth, and in accordance with the terms and conditions herein specified.



## Cost Summary

### SUMMARY SCHEDULE

NO	DESCRIPTION	QUANTITY	UNIT	UNIT COST	TOTAL COST
1.	Provide Equipment, Labor and Material to Prepare the Existing Concrete Floor Garage for an Epoxy Finish as per the Contract Specification	8,800	Square Foot		
	<b>Total Cost</b>	<u>8,800</u>	<u>Square foot</u>	<u>\$4.56</u>	<u>\$40,155.<sup>00</sup></u>

Cost in written form: Forty thousand, one hundred fifty five Dollars

**\*AWARDED VENDOR SHALL PROVIDE COLOR SELECTION GUIDE AND MATERIAL SPECS WITH THE BID**

All bids shall be sealed and returned prior to the bid opening at 11:00AM. on Thursday, August 13, 2015 at the City of Darien, 1702 Plainfield Road, Darien, Illinois, 60561.

1. The contract shall be awarded on a **Total Cost** the awarded vendor/installer shall provide a one year performance bond in the amount of \$10,000.
2. By providing a bid to the City of Darien we hereby attest that we have made site visit and are in general agreement with the dimensions provided.

#### END OF SPECIFICATION

Firm Name: concrete Solutions Int LLC  
 Signature of Authorized Representative: Michael Voknin  
 Title: president Date: 7/30/15

**ACCEPTANCE:** This proposal is valid for 45calendar days from the date of submittal.

**BUSINESS ORGANIZATION:**

\_\_\_\_\_ Sole Proprietor: An individual whose signature is affixed to this bid.

\_\_\_\_\_ Partnership: Attach sheet and state full names, titles and address of all responsible principals and/or partners.

Corporation: State of incorporation: Illinois LLC corporation

Provide a disclosure of all officers and principals by name and business address, date of incorporation and indicate if the corporation is authorized to do business in Illinois. In submitting this bid, it is understood that the City of Darien reserves the right to reject any or all bids, to accept an alternate bid, and to waive any informalities in any bid. In compliance with your Invitation to Bid, and subject to all conditions thereof, the undersigned offers and agrees, if this bid is accepted, to furnish the services as outlined.

Concrete Solutions Int LLC (Corporate Seal)

Business Name

Michael Vaknin

Signature

president

Title

Michael Vaknin

Print or type name

7/30/15

Date

**CERTIFICATION OF ELIGIBILITY TO ENTER INTO PUBLIC CONTRACTS**

**IMPORTANT: THIS CERTIFICATION MUST BE EXECUTED.**

I, Michael Vaknin, being first duly sworn certify  
and say that I am president  
(insert "sole City of Darien," "partner," "president," or other proper title) of  
Concrete Solutions Int LLC, the Prime Contractor  
submitting this proposal, and that the Prime Contractor is not barred from contracting with any  
unit of state or local government as a result of a violation of either Section 33E-3, or 33E-4 of the  
Illinois Criminal Code, or of any similar offense of "bid-rigging" or "bid-rotating" of any state or  
of the United States.

Michael Vaknin  
Signature of Person Making Certification

Subscribed and Sworn To  
Before Me This 7<sup>th</sup> Day

Of Aug, 2015.

Trent Phillips  
Notary Public



**CITY OF DARIEN**

**CONTRACT**

This Contract is made this 3rd day of August, 2015 by and between the City of Darien (hereinafter referred to as the "CITY") and concrete Solutions Int LLC (Hereinafter referred to as the "CONTRACTOR").

**WITNESSETH**

In consideration of the promises and covenants made herein by the CITY and the CONTRACTOR (hereinafter referred to collectively as the "PARTIES"), the PARTIES agree as follows:

**SECTION 1: THE CONTRACT DOCUMENTS:** This Contract shall include the following documents (hereinafter referred to as the "CONTRACT DOCUMENTS") however this Contract takes precedence and controls over any contrary provision in any of the CONTRACT DOCUMENTS. The Contract, including the CONTRACT DOCUMENTS, expresses the entire agreement between the PARTIES and where it modifies, adds to or deletes provisions in other CONTRACT DOCUMENTS; the Contract's provisions shall prevail. Provisions in the CONTRACT DOCUMENTS unmodified by this Contract shall be in full force and effect in their unaltered condition.

- The Invitation to Bid
- The Instructions to the Bidders
- This Contract
- The Terms and Conditions
- The Bid as it is responsive to the CITY'S bid requirements
- All Certifications required by the City
- Certificates of insurance
- Performance and Payment Bonds as may be required by the CITY

**SECTION 2: SCOPE OF THE WORK AND PAYMENT:** The CONTRACTOR agrees to provide labor, equipment and materials necessary to provide the services as described in the CONTRACT DOCUMENTS and further described below:

**Unit Pricing for the:**

**City of Darien  
2015 Public Works Garage Floor Epoxy Coating Project**

(Hereinafter referred to as the "WORK") and the CITY agrees to pay the CONTRACTOR Pursuant to the provisions of the Local Government Prompt Payment Act (50 ILCS 505/1 *et seq.*) the following amount for performance of the described unit prices.

**SECTION 3: ASSIGNMENT:** CONTRACTOR shall not assign the duties and obligations involved in the performance of the WORK which is the subject matter of this Contract without the written consent of the CITY.

**SECTION 4: TERM OF THE CONTRACT:** This Contract shall commence on the date of its execution. The WORK shall commence upon receipt of a Notice to Proceed and continue for the period specified. This Contract shall terminate upon completion of the WORK, but may be terminated by either of the PARTIES for default upon failure to cure after ten (10) days prior written notice of said default from the aggrieved PARTY. The CITY, for its convenience, may terminate this Contract with thirty (30) days prior written notice.

**SECTION 5: INDEMNIFICATION AND INSURANCE:** The CONTRACTOR shall indemnify and hold harmless the CITY, its officials, officers, directors, agents, employees and representatives and assigns, from lawsuits, actions, costs (including attorneys' fees), claims or liability of any character, incurred due to the alleged negligence of the CONTRACTOR, brought because of any injuries or damages received or sustained by any person, persons or property on account of any act or omission, neglect or misconduct of said CONTRACTOR, its officers, agents and/or employees arising out of, or in performance of any of the provisions of the CONTRACT DOCUMENTS, including any claims or amounts recovered for any infringements of patent, trademark or copyright; or from any claims or amounts arising or recovered under the "Worker's Compensation Act" or any other law, ordinance, order or decree. In connection with any such claims, lawsuits, actions or liabilities, the CITY, its officials, officers, directors, agents, employees, representatives and their assigns shall have the right to defense counsel of their choice. The CONTRACTOR shall be solely liable for all costs of such defense and for all expenses, fees, judgments, settlements and all other costs arising out of such claims, lawsuits, actions or liabilities. The Contractor shall not make any settlement or compromise of a lawsuit or claim, or fail to pursue any available avenue of appeal of any adverse judgment, without the approval of the City and any other indemnified party. The City or any other indemnified party, in its or their sole discretion, shall have the option of being represented by its or their own counsel. If this option is exercised, then the Contractor shall promptly reimburse the City or other indemnified party, upon written demand, for any expenses, including but not limited to court costs, reasonable attorneys' and witnesses' fees and other expenses of litigation incurred by the City or other indemnified party in connection therewith. Execution of this Contract by the CITY is contingent upon receipt of Insurance Certificates provided by the CONTRACTOR in compliance with the CONTRACT DOCUMENTS.

**SECTION 6: COMPLIANCE WITH LAWS:** The bidder shall at all times observe and comply with all laws, ordinances and regulations of the federal, state, local and City governments, which may in any manner affect the preparation of bids or the performance of the Contract. Bidder hereby agrees that it will comply with all requirements of the Illinois Human Rights Act, 775 ILCS 5/1-101 et seq., including the provision dealing with sexual harassment and that if awarded the Contract will not engage in any prohibited form of discrimination in employment as defined in that Act and will require that its subcontractors agree to the same restrictions. The contractor shall maintain, and require that its subcontractors maintain, policies of equal employment opportunity which shall prohibit discrimination against any employee or applicant for employment on the basis of race, religion, color, sex, national origin, ancestry, citizenship status, age, marital status, physical or mental disability unrelated to the individual's ability to perform the essential functions of the job, association with a person with a disability, or unfavorable discharge from military service. Contractors and all subcontractors shall comply with all requirements of the Act and of the Rules of the Illinois Department of Human Rights With regard to posting information on employees' rights under the Act. Contractors and all subcontractors shall place appropriate statements identifying their companies as equal Opportunity employers in all advertisements for workers to be employed in work to be performed. Not less than the Prevailing Rate of Wages as found by the City of Darien or the Department of Labor shall be paid to laborers, workmen, and mechanics performing work under the Contract. If awarded the Contract, contractor must comply with all provisions of the Illinois Prevailing Wage Act, including, but not limited to, providing certified payroll records to the Municipal Services Department. Contractor and subcontractors shall be required to comply with all applicable federal laws, state laws and regulations regarding minimum wages, limit on payment to minors, minimum fair wage standards for minors, payment of wage due employees,

and health and safety of employees. Contractor and subcontractor are required to pay employees all rightful salaries, medical benefits, pension and social security benefits pursuant to applicable labor agreements and federal and state statutes and to further require withholdings and deposits therefore. The CONTRACTOR shall obtain all necessary local and state licenses and/or permits that may be required for performance of the WORK and provide those licenses to the CITY prior to commencement of the WORK if applicable.

**SECTION 7: NOTICE:** Where notice is required by the CONTRACT DOCUMENTS it shall be considered received if it is delivered in person, sent by registered United States mail, return receipt requested, delivered by messenger or mail service with a signed receipt, sent by facsimile or e-mail with an acknowledgment of receipt, to the following:

City of Darien  
1702 Plainfield Road  
Darien, IL 60561  
Attn: Director of Municipal Services

**SECTION 8: STANDARD OF SERVICE:** Services shall be rendered to the highest professional standards to meet or exceed those standards met by others providing the same or similar services in the Chicagoland area. Sufficient competent personnel shall be provided who with supervision shall complete the services required within the time allowed for performance. The CONTRACTOR'S personnel shall, at all times present a neat appearance and shall be trained to handle all contact with City residents or City employees in a respectful manner. At the request of the Director of Municipal Services or a designee, the CONTRACTOR shall replace any incompetent, abusive or disorderly person in its employ.

**SECTION 9: PAYMENTS TO OTHER PARTIES:** The CONTRACTOR shall not obligate the CITY to make payments to third parties or make promises or representations to third parties on behalf of the CITY without prior written approval of the City Administrator or a designee.

**SECTION 10: COMPLIANCE:** CONTRACTOR shall comply with all of the requirements of the Contract Documents, including, but not limited to, the Illinois Prevailing Wage Act where applicable and all other applicable local, state and federal statutes, ordinances, codes, rules and regulations.

**SECTION 11: LAW AND VENUE:** The laws of the State of Illinois shall govern this Contract and venue for legal disputes shall be DuPage County, Illinois.

**SECTION 12: MODIFICATION:** This Contract may be modified only by a written amendment signed by both PARTIES.

FOR: THE CITY

FOR: THE CONTRACTOR

By: \_\_\_\_\_

by: Concrete Solutions Int LLC

Print Name: \_\_\_\_\_

Print Name: Michael Vornin

Title: Mayor

Title: president

Date: \_\_\_\_\_

Date: 7/30/15

**AGENDA MEMO**  
**Municipal Services Committee**  
**August 24, 2015**

**ISSUE STATEMENT**

A resolution authorizing the Mayor to execute a contract with Alliance Contractors Inc. in an amount not to exceed \$120,545.00, which includes \$10,000 contingency for unforeseen condition requiring attention, for the reconstruction of the Carlisle Court Storm Water Drainage Infrastructure Reconstruction Project located within the 8700 block of Carlisle Court.

**BACKGROUND/HISTORY**

In 2014, staff identified that the existing Carlisle Court Bridge was in need of repair. Staff had identified deficiencies with the structure consisting of vertical and horizontal cracks along with displacement. A structural review of the infrastructure was completed by Christopher B. Burke Engineering and the engineer had recommended replacing the structure. The structure serves as a roadway bridge and a tributary creek. In 2014, the Kentwood Court Bridge underwent similar renovations.

The scope of the proposed contract includes the removal and replacement of the concrete box culverts under Carlisle Court along with embankment improvements on both sides of the roadway. The roadway will be realigned to match the existing roadway and includes landscape restoration.

Attached and labeled as Attachment 1 is the bid tally and Attachment 2 is the recommendation from Christopher B. Burke Engineering.

The proposed expenditure would be expended from the following account:

ACCOUNT NUMBER	PROJECT CODE	ACCOUNT DESCRIPTION	BUDGET	APPROVALS TO DATE	PROPOSED EXPENDITURE	PROPOSED BALANCE
25-35-4376	FYE165004	CAPITAL-CARLISLE COURT-ENGINEERING	\$ 184,000.00	\$ 18,800.00	N/A	\$ 165,200.00
25-35-4376	FYE165004	CAPITAL-CARLISLE COURT-CONTRACT AWARD ALT BID	N/A	N/A	\$ 108,895.00	\$ 56,305.00
25-35-4376	FYE165004	CAPITAL-CARLISLE COURT-CONTINGENCY	N/A	N/A	\$ 10,000.00	\$ 46,305.00
25-35-4376	FYE165004	TOTALS	\$ 184,000.00	\$ 18,800.00	\$ 118,895.00	\$ 46,305.00

The references for Alliance Contractors Inc, Inc. have been verified with favorable comments.

**STAFF RECOMMENDATION**

Staff recommends approval of this resolution authorizing the Mayor to execute a contract with Alliance Contractors Inc. in an amount not to exceed \$120,545.00, which includes \$10,000 contingency for unforeseen conditions requiring attention, for the reconstruction of the Carlisle Court Storm Water Drainage Infrastructure Reconstruction Project located within the 8700 block of Carlisle Court

**ALTERNATE DECISION**

Not approving the resolution.

Carlisle Court Bridge Repairs  
August 24, 2015  
Page 2

**DECISION MODE**

This item will be placed on the September 8, 2015 City Council agenda for formal consideration.



Christopher B. Burke Engineering, Ltd.  
 9575 West Higgins Road, Suite 600  
 Rosemont, Illinois 60018  
 Project Number: 150254  
 Date: August 12, 2015

BASE BID					ENGINEER'S ESTIMATE		KOVILIC CONSTRUCTION CO., INC.		HERLIHY MID-CONTINENT COMPANY		A LAMP CONCRETE CONTRACTORS, INC.		ALLIANCE CONTRACTORS, INC.		AUSTIN TYLER CONSTRUCTION, INC.	
SP	CODE NUMBER	PAY ITEM	UNIT	QUANTITY	UNIT PRICE	TOTAL	UNIT PRICE	TOTAL	UNIT PRICE	TOTAL	UNIT PRICE	TOTAL	UNIT PRICE	TOTAL	UNIT PRICE	TOTAL
	30300001	AGGREGATE SUBGRADE IMPROVEMENT	CU YD	60	\$ 125.00	\$ 7,500.00	\$ 100.00	\$ 6,000.00	\$ 25.00	\$ 1,500.00	\$ 45.00	\$ 2,700.00	\$ 34.00	\$ 2,040.00	\$ 200.00	\$ 12,000.00
	44000500	COMBINATION CURB AND GUTTER REMOVAL	FOOT	48	\$ 50.00	\$ 2,400.00	\$ 20.00	\$ 960.00	\$ 16.00	\$ 768.00	\$ 8.00	\$ 384.00	\$ 15.00	\$ 720.00	\$ 20.00	\$ 960.00
	44201723	CLASS D PATCHES, TYPE IV, 6 INCH	SQ YD	75	\$ 75.00	\$ 5,625.00	\$ 180.00	\$ 13,500.00	\$ 227.00	\$ 17,025.00	\$ 100.00	\$ 7,500.00	\$ 132.00	\$ 9,900.00	\$ 275.00	\$ 20,625.00
	50101500	REMOVAL OF EXISTING SUPERSTRUCTURES	EACH	1	\$ 15,000.00	\$ 15,000.00	\$ 23,000.00	\$ 23,000.00	\$ 22,000.00	\$ 22,000.00	\$ 30,000.00	\$ 30,000.00	\$ 16,310.00	\$ 16,310.00	\$ 12,500.00	\$ 12,500.00
	50200100	STRUCTURE EXCAVATION	CU YD	25	\$ 80.00	\$ 2,000.00	\$ 100.00	\$ 2,500.00	\$ 25.00	\$ 625.00	\$ 65.00	\$ 1,625.00	\$ 45.00	\$ 1,125.00	\$ 140.00	\$ 3,500.00
	50300255	CONCRETE SUPERSTRUCTURE	CU YD	28	\$ 1,300.00	\$ 36,400.00	\$ 1,500.00	\$ 42,000.00	\$ 630.00	\$ 17,640.00	\$ 3,100.00	\$ 86,800.00	\$ 1,515.00	\$ 42,420.00	\$ 2,500.00	\$ 70,000.00
	50300260	BRIDGE DECK GROOVING	SQ YD	33	\$ 15.00	\$ 495.00	\$ 150.00	\$ 4,950.00	\$ 85.00	\$ 2,805.00	\$ 110.00	\$ 3,630.00	\$ 15.00	\$ 495.00	\$ 40.00	\$ 1,320.00
	50800205	REINFORCEMENT BARS, EPOXY COATED	POUND	2,500	\$ 3.00	\$ 7,500.00	\$ 3.00	\$ 7,500.00	\$ 3.00	\$ 7,500.00	\$ 5.00	\$ 12,500.00	\$ 2.25	\$ 5,625.00	\$ 5.00	\$ 12,500.00
	60608562	COMBINATION CONCRETE CURB AND GUTTER, TYPE M-4.12	FOOT	48	\$ 80.00	\$ 3,840.00	\$ 50.00	\$ 2,400.00	\$ 190.00	\$ 9,120.00	\$ 55.00	\$ 2,640.00	\$ 75.00	\$ 3,600.00	\$ 80.00	\$ 3,840.00
	67100100	MOBILIZATION	L SUM	1	\$ 6,000.00	\$ 6,000.00	\$ 10,000.00	\$ 10,000.00	\$ 6,000.00	\$ 6,000.00	\$ 15,000.00	\$ 15,000.00	\$ 12,685.00	\$ 12,685.00	\$ 3,000.00	\$ 3,000.00
*	X7010216	TRAFFIC CONTROL AND PROTECTION, (SPECIAL)	L SUM	1	\$ 4,000.00	\$ 4,000.00	\$ 10,000.00	\$ 10,000.00	\$ 20,000.00	\$ 20,000.00	\$ 26,500.00	\$ 26,500.00	\$ 2,395.00	\$ 2,395.00	\$ 3,000.00	\$ 3,000.00
*	Z0012754	STRUCTURAL REPAIR OF CONCRETE (DEPTH EQUAL TO OR LESS THAN 5 INCHES)	SQ FT	16	\$ 350.00	\$ 5,600.00	\$ 250.00	\$ 4,000.00	\$ 150.00	\$ 2,400.00	\$ 450.00	\$ 7,200.00	\$ 325.00	\$ 5,200.00	\$ 200.00	\$ 3,200.00
*	Z0018905	DRILL AND GROUT BARS	EACH	80	\$ 75.00	\$ 6,000.00	\$ 25.00	\$ 2,000.00	\$ 40.00	\$ 3,200.00	\$ 25.00	\$ 2,000.00	\$ 25.00	\$ 2,000.00	\$ 50.00	\$ 4,000.00
*	50901730	BRIDGE FENCE RAILING	FOOT	66	\$ 125.00	\$ 8,250.00	\$ 100.00	\$ 6,600.00	\$ 110.00	\$ 7,260.00	\$ 75.00	\$ 4,950.00	\$ 80.00	\$ 5,280.00	\$ 182.00	\$ 12,012.00
*		LANDSCAPE RESTORATION	L SUM	1	\$ 4,000.00	\$ 4,000.00	\$ 3,000.00	\$ 3,000.00	\$ 3,500.00	\$ 3,500.00	\$ 13,500.00	\$ 13,500.00	\$ 750.00	\$ 750.00	\$ 2,500.00	\$ 2,500.00
					TOTAL = \$ 114,700.00		\$ 138,410.00		\$ 121,343.00		\$ 216,929.00		\$ 110,545.00		\$ 164,957.00	

\*INDICATES SPECIAL PROVISION

ALTERNATE BID					ENGINEER'S ESTIMATE		KOVILIC CONSTRUCTION CO., INC.		HERLIHY MID-CONTINENT COMPANY		A LAMP CONCRETE CONTRACTORS, INC.		ALLIANCE CONTRACTORS, INC.		AUSTIN TYLER CONSTRUCTION, INC.	
SP	CODE NUMBER	PAY ITEM	UNIT	QUANTITY	UNIT PRICE	TOTAL	UNIT PRICE	TOTAL	UNIT PRICE	TOTAL	UNIT PRICE	TOTAL	UNIT PRICE	TOTAL	UNIT PRICE	TOTAL
	30300001	AGGREGATE SUBGRADE IMPROVEMENT	CU YD	60	\$ 125.00	\$ 7,500.00	\$ 100.00	\$ 6,000.00	\$ 25.00	\$ 1,500.00	\$ -	\$ -	\$ 34.00	\$ 2,040.00	\$ 200.00	\$ 12,000.00
	44000500	COMBINATION CURB AND GUTTER REMOVAL	FOOT	48	\$ 50.00	\$ 2,400.00	\$ 20.00	\$ 960.00	\$ 16.00	\$ 768.00	\$ -	\$ -	\$ 15.00	\$ 720.00	\$ 20.00	\$ 960.00
	44201335	CLASS C PATCHES, TYPE IV, 8 INCH	SQ YD	75	\$ 120.00	\$ 9,000.00	\$ 200.00	\$ 15,000.00	\$ 190.00	\$ 14,250.00	\$ -	\$ -	\$ 110.00	\$ 8,250.00	\$ 250.00	\$ 18,750.00
	50101500	REMOVAL OF EXISTING SUPERSTRUCTURES	EACH	1	\$ 15,000.00	\$ 15,000.00	\$ 23,000.00	\$ 23,000.00	\$ 22,000.00	\$ 22,000.00	\$ -	\$ -	\$ 16,310.00	\$ 16,310.00	\$ 12,500.00	\$ 12,500.00
	50200100	STRUCTURE EXCAVATION	CU YD	25	\$ 80.00	\$ 2,000.00	\$ 100.00	\$ 2,500.00	\$ 25.00	\$ 625.00	\$ -	\$ -	\$ 45.00	\$ 1,125.00	\$ 140.00	\$ 3,500.00
	50300255	CONCRETE SUPERSTRUCTURE	CU YD	28	\$ 1,300.00	\$ 36,400.00	\$ 1,500.00	\$ 42,000.00	\$ 630.00	\$ 17,640.00	\$ -	\$ -	\$ 1,515.00	\$ 42,420.00	\$ 2,500.00	\$ 70,000.00
	50300260	BRIDGE DECK GROOVING	SQ YD	33	\$ 15.00	\$ 495.00	\$ 150.00	\$ 4,950.00	\$ 85.00	\$ 2,805.00	\$ -	\$ -	\$ 15.00	\$ 495.00	\$ 40.00	\$ 1,320.00
	50800205	REINFORCEMENT BARS, EPOXY COATED	POUND	2,500	\$ 3.00	\$ 7,500.00	\$ 3.00	\$ 7,500.00	\$ 3.00	\$ 7,500.00	\$ -	\$ -	\$ 2.25	\$ 5,625.00	\$ 5.00	\$ 12,500.00
	60608562	COMBINATION CONCRETE CURB AND GUTTER, TYPE M-4.12	FOOT	48	\$ 80.00	\$ 3,840.00	\$ 50.00	\$ 2,400.00	\$ 190.00	\$ 9,120.00	\$ -	\$ -	\$ 75.00	\$ 3,600.00	\$ 80.00	\$ 3,840.00
	67100100	MOBILIZATION	L SUM	1	\$ 6,000.00	\$ 6,000.00	\$ 10,000.00	\$ 10,000.00	\$ 6,000.00	\$ 6,000.00	\$ -	\$ -	\$ 12,685.00	\$ 12,685.00	\$ 3,000.00	\$ 3,000.00
*	X7010216	TRAFFIC CONTROL AND PROTECTION, (SPECIAL)	L SUM	1	\$ 4,000.00	\$ 4,000.00	\$ 10,000.00	\$ 10,000.00	\$ 20,000.00	\$ 20,000.00	\$ -	\$ -	\$ 2,395.00	\$ 2,395.00	\$ 3,000.00	\$ 3,000.00
*	Z0012754	STRUCTURAL REPAIR OF CONCRETE (DEPTH EQUAL TO OR LESS THAN 5 INCHES)	SQ FT	16	\$ 350.00	\$ 5,600.00	\$ 250.00	\$ 4,000.00	\$ 150.00	\$ 2,400.00	\$ -	\$ -	\$ 325.00	\$ 5,200.00	\$ 200.00	\$ 3,200.00
*	Z0018905	DRILL AND GROUT BARS	EACH	80	\$ 75.00	\$ 6,000.00	\$ 25.00	\$ 2,000.00	\$ 40.00	\$ 3,200.00	\$ -	\$ -	\$ 25.00	\$ 2,000.00	\$ 50.00	\$ 4,000.00
*	50901730	BRIDGE FENCE RAILING	FOOT	66	\$ 125.00	\$ 8,250.00	\$ 100.00	\$ 6,600.00	\$ 110.00	\$ 7,260.00	\$ -	\$ -	\$ 80.00	\$ 5,280.00	\$ 182.00	\$ 12,012.00
*		LANDSCAPE RESTORATION	L SUM	1	\$ 4,000.00	\$ 4,000.00	\$ 3,000.00	\$ 3,000.00	\$ 3,500.00	\$ 3,500.00	\$ -	\$ -	\$ 750.00	\$ 750.00	\$ 2,500.00	\$ 2,500.00
					TOTAL = \$ 118,000.00		\$ 139,910.00		\$ 118,568.00		\$ -		\$ 108,895.00		\$ 163,082.00	

\*INDICATES SPECIAL PROVISION

**CHRISTOPHER B. BURKE ENGINEERING, LTD.**

9575 West Higgins Road Suite 600 Rosemont, Illinois 60018 TEL (847) 823-0500 FAX (847) 823-0520

August 18, 2015

*Sent via electronic mail*

City of Darien  
Public Works Department  
1041 S. Frontage Road  
Darien, IL 60561

Attention: Dan Gombac, Director of Municipal Services

Subject: Carlisle Court Culvert Repairs – Bid Recommendation

Dear Mr. Gombac:

Bids for the subject project were opened and read aloud at 3:30 P.M. on August 12, 2015 at the Darien City Hall. Those bids have been reviewed and tabulated. The following is a summary:

BIDDER:	BASE BID	ALTERNATE BID
Engineer's Estimate	\$114,700	\$118,075
Kovilic Construction	\$138,410	\$139,910
Herlihy Mid-Continent	\$121,343	\$118,568
A-Lamp	\$216,929	-
Austin Tyler Construction, Inc.	\$164,957	\$163,082
Alliance Contractors, Inc.	\$110,545	\$108,895

The lowest bidder is Alliance Contractors, Inc. for both the Base Bid and Alternate Bid options. We therefore recommend awarding the contract to Alliance Contractors in the amount of \$108,895 for the repairs to the Carlisle Court Culvert using the Alternate Bid alternative (Concrete Patching). They are a reputable company in the industry and we are familiar with their work.

If you have any questions, please do not hesitate to contact me.

Regards,

Jeffrey C. Ehrhart, PE  
Senior Structural Engineer

Enclosures



Illinois Department of Transportation

Signatures

Route: --
County: DuPage
Local Agency: City of Darien
Section: -----

RETURN WITH BID

(If an individual)

Signature of Bidder

Business Address

(If a partnership)

Firm Name

Signed By

Business Address

Insert Names and Addresses of All Partners

(If a corporation)

Corporate Name: Alliance Contractors, Inc

Signed By: Scott A. Jarnard, Vice President

Business Address: 1166 Lake Avenue, Woodstock, IL 60098

Insert Names of Officers

President: Michael J. Paulson
Secretary: Helen J. Ruth
Treasurer:

Attest: [Signature] ASST Secretary



**Illinois Department  
of Transportation**

**Signatures**

Route	_____
County	DuPage
Local Agency	City of Darien
Section	_____

**RETURN WITH BID**

(If an individual)

Signature of Bidder \_\_\_\_\_

Business Address \_\_\_\_\_

(If a partnership)

Firm Name \_\_\_\_\_

Signed By \_\_\_\_\_

Business Address \_\_\_\_\_

\_\_\_\_\_

\_\_\_\_\_

\_\_\_\_\_

\_\_\_\_\_

\_\_\_\_\_

Insert  
Names and  
Addresses of  
All Partners

(If a corporation)

Corporate Name \_\_\_\_\_

Signed By \_\_\_\_\_

President

Business Address \_\_\_\_\_

\_\_\_\_\_

\_\_\_\_\_

\_\_\_\_\_

Insert  
Names of  
Officers



President \_\_\_\_\_

Secretary \_\_\_\_\_

Treasurer \_\_\_\_\_

Attest: \_\_\_\_\_  
Secretary

RESOLUTION NO. \_\_\_\_\_

**A RESOLUTION AUTHORIZING THE MAYOR TO EXECUTE A CONTRACT WITH ALLIANCE CONTRACTORS, INC. IN AN AMOUNT NOT TO EXCEED \$120,545.00, WHICH INCLUDES \$10,000.00 CONTINGENCY FOR UNFORESEEN CONDITIONS REQUIRING ATTENTION, FOR THE RECONSTRUCTION OF THE CARLISLE COURT STORM WATER DRAINAGE INFRASTRUCTURE PROJECT LOCATED WITHIN THE 8700 BLOCK OF CARLISLE COURT**

**BE IT RESOLVED BY THE CITY COUNCIL OF THE CITY OF DARIEN, DU PAGE COUNTY, ILLINOIS, as follows:**

**SECTION 1:** The City Council of the City of Darien, hereby authorizes the Mayor to execute a contract with Alliance Contractors Inc. in an amount not to exceed \$120,545.00 which includes \$10,000 contingency for unforeseen conditions requiring attention, for the reconstruction of the Carlisle Court Storm Water Drainage Infrastructure Project located within the 8700 block of Carlisle Court, which is attached hereto as "Exhibit A" and is by this reference expressly incorporated herein.

**SECTION 2:** This Resolution shall be in full force and effect from and after its passage and approval as provided by law.

**PASSED BY THE CITY COUNCIL OF THE CITY OF DARIEN, DU PAGE COUNTY, ILLINOIS, this 8th day of September, 2015.**

AYES: \_\_\_\_\_

NAYS: \_\_\_\_\_

ABSENT: \_\_\_\_\_

**APPROVED BY THE MAYOR OF THE CITY OF DARIEN, DU PAGE COUNTY, ILLINOIS, this 8th day of September, 2015.**

\_\_\_\_\_  
KATHLEEN MOESLE WEAVER, MAYOR

ATTEST:

\_\_\_\_\_  
JOANNE E. RAGONA, CITY CLERK

APPROVED AS TO FORM:

\_\_\_\_\_  
CITY ATTORNEY

**Local Public Agency  
Formal Contract**

PROPOSAL SUBMITTED BY		
Alliance Contractors Inc.		
Contractor's Name		
1166 Lake Ave		
Street		P.O. Box
Woodstock	IL	60098
City	State	Zip Code

STATE OF ILLINOIS

COUNTY DuPage  
City of Darien  
(Name of City, Village, Town or Road District)

FOR THE IMPROVEMENT OF  
STREET NAME OR ROUTE Carlisle Court  
SECTION NO. N/A  
TYPES OF FUNDS Local

SPECIFICATIONS (required)

PLANS (required)

CONTRACT BOND (when required)

**THIS IS NOT AN IDOT PROJECT**

County DuPage  
Local Public Agency City of Darien  
Section Number N/A  
Route Carlisle Court

1. THIS AGREEMENT, made and concluded the \_\_\_\_\_ day of \_\_\_\_\_, \_\_\_\_\_  
Month and Year  
between the City of Darien  
acting by and through its Mayor and Council known as the party of the first part, and  
\_\_\_\_\_ his/their executors, administrators, successors or assigns,  
known as the party of the second part.

2. Witnesseth: That for and in consideration of the payments and agreements mentioned in the Proposal hereto attached, to be made and performed by the party of the first part, and according to the terms expressed in the Bond referring to these presents, the party of the second part agrees with said party of the first part at his/their own proper cost and expense to do all the work, furnish all materials and all labor necessary to complete the work in accordance with the plans and specifications hereinafter described, and in full compliance with all of the terms of this agreement and the requirements of the Engineer under it.

3. And it is also understood and agreed that the LPA Formal Contract Proposal, Special Provisions, Affidavit of Illinois Business Office, Apprenticeship or Training Program Certification, and Contract Bond hereto attached, and the Plans for Carlisle Court Culvert Repairs, in The City of Darien, approved by the Illinois Department of Transportation on N/A, \_\_\_\_\_, are essential documents of this contract and are a part hereof.  
Date

4. IN WITNESS WHEREOF, The said parties have executed these presents on the date above mentioned.

Attest: \_\_\_\_\_ The City of Darien  
Clerk By \_\_\_\_\_  
Party of the First Part

(Seal) \_\_\_\_\_  
*(If a Corporation)*  
Corporate Name \_\_\_\_\_

By \_\_\_\_\_  
President Party of the Second Part

*(If a Co-Partnership)*

Attest: \_\_\_\_\_  
Secretary

Partners doing Business under the firm name of

Party of the Second Part

*(If an individual)*

Party of the Second Part

**Contract Bond**

Route Carlisle Court  
County DuPage  
Local Agency Darien  
Section N/A

We, \_\_\_\_\_

a/an)  Individual  Co-partnership  Corporation organized under the laws of the State of \_\_\_\_\_,  
as PRINCIPAL, and \_\_\_\_\_

\_\_\_\_\_ as SURETY,

are held and firmly bound unto the above Local Agency (hereafter referred to as "LA") in the penal sum of

\_\_\_\_\_ Dollars ( \_\_\_\_\_ ), lawful money of the  
United States, well and truly to be paid unto said LA, for the payment of which we bind ourselves, our heirs, executors,  
administrators, successors, jointly to pay to the LA this sum under the conditions of this instrument.

WHEREAS THE CONDITION OF THE FOREGOING OBLIGATION IS SUCH that, the said Principal has entered into a written contract with the LA acting through its awarding authority for the construction of work on the above section, which contract is hereby referred to and made a part hereof, as if written herein at length, and whereby the said Principal has promised and agreed to perform said work in accordance with the terms of said contract, and has promised to pay all sums of money due for any labor, materials, apparatus, fixtures or machinery furnished to such Principal for the purpose of performing such work and has further agreed to pay all direct and indirect damages to any person, firm, company or corporation suffered or sustained on account of the performance of such work during the time thereof and until such work is completed and accepted; and has further agreed that this bond shall inure to the benefit of any person, firm, company or corporation to whom any money may be due from the Principal, subcontractor or otherwise for any such labor, materials, apparatus, fixtures or machinery so furnished and that suit may be maintained on such bond by any such person, firm, company or corporation for the recovery of any such money.

NOW THEREFORE, if the said Principal shall well and truly perform said work in accordance with the terms of said contract, and shall pay all sums of money due or to become due for any labor, materials, apparatus, fixtures or machinery furnished to him for the purpose of constructing such work, and shall commence and complete the work within the time prescribed in said contract, and shall pay and discharge all damages, direct and indirect, that may be suffered or sustained on account of such work during the time of the performance thereof and until the said work shall have been accepted, and shall hold the LA and its awarding authority harmless on account of any such damages and shall in all respects fully and faithfully comply with all the provisions, conditions and requirements of said contract, then this obligation to be void; otherwise to remain in full force and effect.



IN TESTIMONY WHEREOF, the said PRINCIPAL and the said SURETY have caused this instrument to be signed by their respective officers this \_\_\_\_\_ day of \_\_\_\_\_ A.D. 2015

**PRINCIPAL**

\_\_\_\_\_  
(Company Name)

\_\_\_\_\_  
(Company Name)

By: \_\_\_\_\_  
(Signature & Title)

By: \_\_\_\_\_  
(Signature & Title)

Attest: \_\_\_\_\_  
(Signature & Title)

Attest: \_\_\_\_\_  
(Signature & Title)

(If PRINCIPAL is a joint venture of two or more contractors, the company names and authorized signature of each contractor must be affixed.)

STATE OF ILLINOIS,

COUNTY OF \_\_\_\_\_

I, \_\_\_\_\_, a Notary Public in and for said county, do hereby certify that

\_\_\_\_\_  
(Insert names of individuals signing on behalf of PRINCIPAL)

who are each personally known to me to be the same persons whose names are subscribed to the foregoing instrument on behalf of PRINCIPAL, appeared before me this day in person and acknowledged respectively, that they signed and delivered said instrument as their free and voluntary act for the uses and purposes therein set forth.

Given under my hand and notarial seal this \_\_\_\_\_ day of \_\_\_\_\_ A.D. \_\_\_\_\_

My commission expires \_\_\_\_\_  
\_\_\_\_\_  
Notary Public (SEAL)

**SURETY**

\_\_\_\_\_  
(Name of Surety)

By: \_\_\_\_\_  
(Signature of Attorney-in-Fact)

STATE OF ILLINOIS.

(SEAL)

COUNTY OF \_\_\_\_\_

I, \_\_\_\_\_, a Notary Public in and for said county, do hereby certify that

\_\_\_\_\_  
(Insert names of individuals signing on behalf of SURETY)

who are each personally known to me to be the same persons whose names are subscribed to the foregoing instrument on behalf of SURETY, appeared before me this day in person and acknowledged respectively, that they signed and delivered said instrument as their free and voluntary act for the uses and purposes therein set forth.

Given under my hand and notarial seal this \_\_\_\_\_ day of \_\_\_\_\_ A.D. 2015

My commission expires \_\_\_\_\_  
\_\_\_\_\_  
Notary Public (SEAL)

Approved this \_\_\_\_\_ day of \_\_\_\_\_, A.D. \_\_\_\_\_

Attest:

\_\_\_\_\_  
City of Darien  
(Awarding Authority)

\_\_\_\_\_  
Clerk

\_\_\_\_\_  
(Chairman/Mayor/President)



**RETURN WITH BID**

Route	---
County	DuPage
Local Agency	City of Darien
Section	*****

**Time and Place of Opening of Bids**

Sealed proposals for the improvement described below will be received at the office of Darien City Hall

1702 Plainfield Road, Darien, Illinois 60561

until	<u>3:30</u>	o'clock	<u>P</u>	<u>M.</u> ,	<u>August 12, 2015</u>	Proposals will be opened and read publicly
					(date)	
at	<u>3:30</u>	o'clock	<u>P</u>	<u>M.</u> ,	<u>August 12, 2015</u>	at the office of <u>Darien City Hall</u>
					(date)	

1702 Plainfield Road, Darien, Illinois 60561  
(address)

**Description of Work**

Name Carlisle Court Culvert Repairs Length NA feet ( NA miles)

Location Carlisle Court in the City of Darien

Proposed Improvement Remove and replace the top slab of the culvert, minor concrete repairs and approach roadway work

**Bidders Instructions**

1. Plans and proposal forms will be available in the office of Christopher B. Burke Engineering, Ltd.  
9575 W. Higgins Road, Suite 600, Rosemont, IL 60018 for the sum of Sixty Dollars (\$60.00) Non-refundable payable to Christopher B. Burke Engineering, Ltd. as well as a copy of the IDOT "Certification of Eligibility." after 12 p.m. on July 27, 2015.
2. If prequalification is required, the 2 low bidders must file within 24 hours after the letting an "Affidavit of Availability" (Form BC 57), in triplicate, showing all uncompleted contracts awarded to them and all low bids pending award for Federal, State, County, Municipal and private work. One copy shall be filed with the Awarding Authority and 2 copies with the IDOT District Office.
3. All proposals must be accompanied by a proposal guaranty as provided in BLRS Special Provision for Bidding Requirements and Conditions for Contract Proposals contained in the "Supplemental Specifications and Recurring Special Provisions".
4. The Awarding Authority reserves the right to waive technicalities and to reject any or all proposals as provided in BLRS Special Provision for Bidding Requirements and Conditions for Contract Proposals contained in the "Supplemental Specifications and Recurring Special Provisions".
5. Bidders need not return the entire contract proposal when bids are submitted unless otherwise required. Portions of the proposal that must be returned include the following:
 

a. BLR 12210 - Contract Cover	f. BLR 12230 - Proposal Bid Bond (if applicable)
b. BLR 12220 - Notice to Bidders	g. BLR 12325 - Apprenticeship or Training Program Certification (do not use for federally funded projects)
c. BLR 12221 - Contract Proposal	
d. BLR 12222 - Contract Schedule of Prices	
e. BLR 12223 - Signatures	
6. The quantities appearing in the bid schedule are approximate and are prepared for the comparison of bids. Payment to the Contractor will be made only for the actual quantities of work performed and accepted or materials furnished according to the contract. The scheduled quantities of work to be done and materials to be furnished may be increased, decreased or omitted as hereinafter provided.

7. Submission of a bid shall be conclusive assurance and warranty the bidder has examined the plans and understands all requirements for the performance of work. The bidder will be responsible for all errors in the proposal resulting from failure or neglect to conduct an in depth examination. The Awarding Authority will, in no case be responsible for any costs, expenses, losses or changes in anticipated profits resulting from such failure or neglect of the bidder.
8. The bidder shall take no advantage of any error or omission in the proposal and advertised contract.
9. If a special envelope is supplied by the Awarding Authority, each proposal should be submitted in that envelope furnished by the Awarding Agency and the blank spaces on the envelope shall be filled in correctly to clearly indicate its contents. When an envelope other than the special one furnished by the Awarding Authority is used, it shall be marked to clearly indicate its contents. When sent by mail, the sealed proposal shall be addressed to the Awarding Authority at the address and in care of the official in whose office the bids are to be received. All proposals shall be filed prior to the time and at the place specified in the Notice to Bidders. Proposals received after the time specified will be returned to the bidder unopened.
10. Permission will be given to a bidder to withdraw a proposal if the bidder makes the request in writing or in person before the time for opening proposals.

By Order of

City of Darien

(Awarding Authority)

JoAnne Ragona

~~County Engineer/County Superintendent of Highways/Municipal Clerk~~

**Note:** All proposal documents, including Proposal Guaranty Checks or Proposal Bid Bonds, should be stapled together to prevent loss when bids are processed.



RETURN WITH BID

Route: \_\_\_\_\_
County: DuPage
Local Agency: City of Darien
Section: \_\_\_\_\_

1. Proposal of Alliance Contractors, Inc

for the improvement of the above section by the construction of

Remove and replace the top slab of the culvert, concrete repairs and approach roadway work

\_\_\_\_\_ a total distance of \_\_\_\_\_ feet, of which a distance of \_\_\_\_\_ feet, ( \_\_\_\_\_ miles) are to be improved.

2. The plans for the proposed work are those prepared by Christopher B. Burke Engineering, Ltd., 9575 W. Higgins Rd, Ste 600, Rosemont, IL 60018 and approved by the Department of Transportation on N/A

3. The specifications referred to herein are those prepared by the Department of Transportation and designated as "Standard Specifications for Road and Bridge Construction" and the "Supplemental Specifications and Recurring Special Provisions" thereto, adopted and in effect on the date of invitation for bids.

4. The undersigned agrees to accept, as part of the contract, the applicable Special Provisions indicated on the "Check Sheet for Recurring Special Provisions" contained in this proposal.

5. The undersigned agrees to complete the work by October 15, 2015 unless additional time is granted in accordance with the specifications.

6. A proposal guaranty in the proper amount, as specified in BLRS Special Provision for Bidding Requirements and Conditions for contract Proposals, will be required. Bid Bonds [X] will [ ] will not be allowed as proposal guaranties. Accompanying this proposal is either a bid bond if allowed, on Department form BLR 12230 or a proposal guaranty check, complying with the specifications, made payable to: City of Darien Treasurer of Clerks Office

the amount of the check is 5% bid bond ( 5% )

7. In the event that one proposal guaranty check is intended to cover two or more proposals, the amount must be equal to the sum of the proposal guaranties, which would be required for each individual proposal. If the proposal guaranty check is placed in another proposal, it will be found in the proposal for: Section Number N/A

8. If this proposal is accepted and the undersigned fails to execute a contract and contract bond as required, it is hereby agreed that the Bid Bond or check shall be forfeited to the Awarding Authority.

9. Each pay item should have a unit price and a total price. If no total price is shown or if there is a discrepancy between the product of the unit price multiplied by the quantity, the unit price shall govern. If a unit price is omitted, the total price will be divided by the quantity in order to establish a unit price.

10. A bid will be declared unacceptable if neither a unit price nor a total price is shown.

11. The undersigned firm certifies that it has not been convicted of bribery or attempting to bribe an officer or employee of the State of Illinois, nor has the firm made an admission of guilt of such conduct which is a matter of record, nor has an official, agent, or employee of the firm committed bribery or attempted bribery on behalf of the firm and pursuant to the direction or authorization of a responsible official of the firm. The undersigned firm further certifies that it is not barred from contracting with any unit of State or local government as a result of a violation of State laws prohibiting bid-rigging or bid-rotating.

12. The undersigned submits herewith the schedule of prices on BLR 12222 covering the work to be performed under this contract.





Route ---  
 County DuPage  
 Local Agency City of Darien  
 Section ----

**RETURN WITH BID**

(For complete information covering these items, see plans and specifications)

**ALTERNATE BID**

Item No.	Items	Unit	Quantity	Unit Price	Total
30300001	AGGREGATE SUBGRADE IMPROVEMENT	CU YD	60	34.00	2,040.00
44000500	COMBINATION CURB AND GUTTER REMOVAL	FOOT	48	15.00	720.00
44201335	CLASS C PATCHES, TYPE IV, 8 INCH	SQ YD	75	110.00	8,250.00
50101500	REMOVAL OF EXISTING SUPERSTRUCTURES	EACH	1	16,310.00	16,310.00
50200100	STRUCTURE EXCAVATION	CU YD	25	45.00	1,125.00
50300255	CONCRETE SUPERSTRUCTURE	CU YD	28	1,515.00	42,420.00
50300260	BRIDGE DECK GROOVING	SQ YD	33	15.00	495.00
50800205	REINFORCEMENT BARS, EPOXY COATED	POUND	2500	2.25	5,625.00
60608562	COMBINATION CONCRETE CURB AND GUTTER, TYPE M-4.12	FOOT	48	75.00	3,600.00
67100100	MOBILIZATION	L SUM	1	12,685.00	12,685.00
*X7010216	TRAFFIC CONTROL AND PROTECTION, (SPECIAL)	L SUM	1	2,395.00	2,395.00
*Z0012754	STRUCTURAL REPAIR OF CONCRETE (DEPTH EQUAL TO OR LESS THAN 5 INCHES)	SQ FT	16	325.00	5,200.00
*Z0018905	DRILL AND GROUT BARS	EACH	80	25.00	2,000.00
*50901730	BRIDGE FENCE RAILING	FOOT	66	80.00	5,280.00
*NA	LANDSCAPE RESTORATION	L SUM	1	750.00	750.00
Bidder's Proposal for ALTERNATE BID.	One hundred Eight Thousand, Eight Hundred Ninety-Five Dollars and Zero Cents			TOTAL	108,895.00

13. The undersigned further agrees that if awarded the contract for the sections contained in the following combinations, he will perform the work in accordance with the requirements of each individual proposal for the multiple bid specified in the schedule below.

**Schedule of Multiple Bids**

Combination Letter	Sections Included in Combination	Total

**AGENDA MEMO**  
**Municipal Services Committee**  
**August 24, 2015**

**Issue Statement**

Consideration for approval of Illinois Department of Transportation Resolutions (IDOT) authorizing expenditure adjustments to balance with the Illinois Department of Transportation Motor Fuel Tax (MFT) audit reviews. The Resolutions are as follows:

Resolution for Maintenance of Streets and Highways by Municipality Under the Illinois Highway Code –  
Section 09-00000-00-GM & 09-00000-01-GM

Resolution for Maintenance of Streets and Highways by Municipality Under the Illinois Highway Code –  
Section 11-00000-00-GM

Resolution for Maintenance of Streets and Highways by Municipality Under the Illinois Highway Code –  
Section 12-00000-00-RF

Resolution for Maintenance of Streets and Highways by Municipality Under the Illinois Highway Code –  
Section 13-00000-00-GM  
Section 13-00000-00-RF

Resolution for Maintenance of Streets and Highways by Municipality Under the Illinois Highway Code –  
Section 14-00000-00-GM  
Section 14-00000-00-RF

**Background/History**

The City of Darien was recently forwarded correspondence from the Illinois Department of Transportation (see attached letter labeled as Attachment A) regarding a Motor Fuel Tax (MFT) audit that was conducted earlier this year. Per the audit review there are items dated back from 2009 to 2015 and a majority of the paperwork requires a staff signature to close out a specified project or an additional City Council approved resolution. City staff has recently met with IDOT officials regarding the paperwork “cleanup” and Officials from IDOT informed staff that they recently brought in consultants to assist in reviewing and closing out all backlogs.

Staff has reviewed the audit and replied with a response, provided signatures and has prepared the IDOT resolutions for City Council approvals.

**Staff Recommendation**

The Staff recommends approval of the Resolutions.

**Alternate Consideration**

No alternate consideration

**Decision Mode**

This item will be placed on the September 8, 2015 City Council agenda for formal consideration.



BE IT RESOLVED, by the Council of the  
 City of Darien Illinois  
City, Town or Village  
 Council or President and Board of Trustees

that the following described street(s) be improved under the Illinois Highway Code:

Name of Thoroughfare	Route	From	To
N/A			

BE IT FURTHER RESOLVED,

1. That the proposed improvement shall consist of Annual General Maintenance

and shall be constructed N/A wide  
 and be designated as Section 09-00000-00-GM & 09-00000-01-GM

2. That there is hereby appropriated the (additional  Yes  No) sum of Seventeen Thousand Four Hundred Twelve  
09/100 Dollars ( \$17,412.09 ) for the  
 improvement of said section from the municipality's allotment of Motor Fuel Tax funds.

3. That work shall be done by Day Labor ; and,  
Specify Contract or Day Labor

BE IT FURTHER RESOLVED, that the Clerk is hereby directed to transmit two certified copies of this resolution to the district office of the Department of Transportation.

<p>Approved</p>  <p>Date</p>  <p>Department of Transportation</p>  <p>Regional Engineer</p>	<p>I, <u>Joanne Ragona</u> Clerk in and for the  <u>Darien</u> City of <u>Darien</u>  <small>City, Town or Village</small>  <u>Dupage</u> County of <u>Dupage</u> , hereby certify the          foregoing to be a true, perfect and complete copy of a resolution adopted          by the <u>Council</u>  <small>Council or President and Board of Trustees</small>          at a meeting on _____  <small>Date</small>          IN TESTIMONY WHEREOF, I have hereunto set my hand and seal this          _____ day of _____          (SEAL)          _____  <small>City, Town, or Village Clerk</small></p>
---	--





**Illinois Department  
of Transportation**

**SUPPLEMENTAL RESOLUTION PER MFT  
SECTION REVIEW 6/2015**

**Resolution for Improvement by  
Municipality Under the Illinois  
Highway Code**

BE IT RESOLVED, by the Council of the  
City of Darien Illinois  
Council or President and Board of Trustees  
City, Town or Village

that the following described street(s) be improved under the Illinois Highway Code:

Name of Thoroughfare	Route	From	To
N/A			

BE IT FURTHER RESOLVED,

1. That the proposed improvement shall consist of General Maintenance

and shall be constructed N/A wide

and be designated as Section 11-00000-00-GM

2. That there is hereby appropriated the (additional  Yes  No) sum of Four Thousand Two Hundred Forty Six  
Dollars and 4/100 Dollars ( \$4,246.04 ) for the  
improvement of said section from the municipality's allotment of Motor Fuel Tax funds.

3. That work shall be done by Day Labor ; and,  
Specify Contract or Day Labor

BE IT FURTHER RESOLVED, that the Clerk is hereby directed to transmit two certified copies of this resolution to the district office of the Department of Transportation.

Approved \_\_\_\_\_

Date \_\_\_\_\_

Department of Transportation

Regional Engineer \_\_\_\_\_

I, Joanne Ragona Clerk in and for the  
City of Darien  
City, Town or Village  
County of Dupage , hereby certify the  
foregoing to be a true, perfect and complete copy of a resolution adopted  
by the Council  
Council or President and Board of Trustees  
at a meeting on \_\_\_\_\_  
Date  
IN TESTIMONY WHEREOF, I have hereunto set my hand and seal this  
\_\_\_\_\_ day of \_\_\_\_\_  
(SEAL)  
\_\_\_\_\_  
City, Town, or Village Clerk



BE IT RESOLVED, by the Council of the  
City of Darien Illinois  
Council or President and Board of Trustees  
City, Town or Village

that the following described street(s) be improved under the Illinois Highway Code:

Name of Thoroughfare	Route	From	To
N/A			

BE IT FURTHER RESOLVED,

1. That the proposed improvement shall consist of Annual General Maintenance

and shall be constructed N/A wide  
and be designated as Section 12-00000-00-RF

2. That there is hereby appropriated the (additional  Yes  No) sum of Forty Thousand Seven Hundred  
Twenty Seven 59/100 Dollars ( \$40,727.59 ) for the  
improvement of said section from the municipality's allotment of Motor Fuel Tax funds.

3. That work shall be done by Day Labor; and,  
Specify Contract or Day Labor

BE IT FURTHER RESOLVED, that the Clerk is hereby directed to transmit two certified copies of this resolution to the district office of the Department of Transportation.

Approved \_\_\_\_\_  
Date \_\_\_\_\_  
Department of Transportation  
Regional Engineer \_\_\_\_\_

I, Joanne Ragona Clerk in and for the  
City of Darien  
City, Town or Village  
County of Dupage, hereby certify the  
foregoing to be a true, perfect and complete copy of a resolution adopted  
by the Council  
Council or President and Board of Trustees  
at a meeting on \_\_\_\_\_  
Date  
IN TESTIMONY WHEREOF, I have hereunto set my hand and seal this  
\_\_\_\_\_ day of \_\_\_\_\_  
(SEAL)  
\_\_\_\_\_  
City, Town, or Village Clerk



BE IT RESOLVED, by the Council of the  
City of Darien Council or President and Board of Trustees  
Illinois  
City, Town or Village

that the following described street(s) be improved under the Illinois Highway Code:

Name of Thoroughfare	Route	From	To
N/A			

BE IT FURTHER RESOLVED,

1. That the proposed improvement shall consist of Annual General Maintenance

and shall be constructed N/A wide  
and be designated as Section 13-00000-00-GM

2. That there is hereby appropriated the (additional  Yes  No) sum of Six Thousand Four Hundred Sixty  
Eight Dollars and 14/100 Dollars ( \$6,468.14 ) for the  
improvement of said section from the municipality's allotment of Motor Fuel Tax funds.

3. That work shall be done by Day Labor; and,  
Specify Contract or Day Labor

BE IT FURTHER RESOLVED, that the Clerk is hereby directed to transmit two certified copies of this resolution to the district office of the Department of Transportation.

<p>Approved</p> <p>Date</p> <p>Department of Transportation</p> <p>Regional Engineer</p>	<p>I, <u>Joanne Ragona</u> Clerk in and for the City of <u>Darien</u> City, Town or Village County of <u>Dupage</u>, hereby certify the foregoing to be a true, perfect and complete copy of a resolution adopted by the <u>Council</u> Council or President and Board of Trustees at a meeting on _____ Date</p> <p>IN TESTIMONY WHEREOF, I have hereunto set my hand and seal this _____ day of _____ (SEAL)</p> <p>_____ City, Town, or Village Clerk</p>
--	--



**Illinois Department  
of Transportation**

**13-00000-00-RF RESOLUTION PER MFT  
SECTION REVIEW 6/2015  
Resolution for Improvement by  
Municipality Under the Illinois  
Highway Code**

BE IT RESOLVED, by the Council of the  
City of Darien Illinois  
Council or President and Board of Trustees  
City, Town or Village

that the following described street(s) be improved under the Illinois Highway Code:

Name of Thoroughfare	Route	From	To
N/A			

BE IT FURTHER RESOLVED,

1. That the proposed improvement shall consist of IMRF-SOCIAL SECURITY-MEDICARE

and shall be constructed N/A wide  
and be designated as Section 13-00000-00-RF

2. That there is hereby appropriated the (additional  Yes  No) sum of Fifty Four Thousand Four Hundred Thirty  
Dollars and 21/100 Dollars ( \$54,430.21 ) for the  
improvement of said section from the municipality's allotment of Motor Fuel Tax funds.

3. That work shall be done by Day Labor ; and,  
Specify Contract or Day Labor

BE IT FURTHER RESOLVED, that the Clerk is hereby directed to transmit two certified copies of this resolution to the district office of the Department of Transportation.

Approved \_\_\_\_\_  
Date \_\_\_\_\_  
Department of Transportation  
Regional Engineer \_\_\_\_\_

I, Joanne Ragona Clerk in and for the  
City of Darien  
City, Town or Village  
County of Dupage , hereby certify the  
foregoing to be a true, perfect and complete copy of a resolution adopted  
by the Council  
Council or President and Board of Trustees  
at a meeting on \_\_\_\_\_  
Date  
IN TESTIMONY WHEREOF, I have hereunto set my hand and seal this  
\_\_\_\_\_ day of \_\_\_\_\_  
(SEAL)  
\_\_\_\_\_  
City, Town, or Village Clerk



BE IT RESOLVED, by the Council of the  
City of Darien Illinois  
Council or President and Board of Trustees  
City, Town or Village

that the following described street(s) be improved under the Illinois Highway Code:

Name of Thoroughfare	Route	From	To
N/A			

BE IT FURTHER RESOLVED,

1. That the proposed improvement shall consist of Annual General Maintenance  
  
  
  
  
and shall be constructed N/A wide  
and be designated as Section 14-00000-00-GM

2. That there is hereby appropriated the (additional  Yes  No) sum of Forty Five Thousand Five Hundred Sixty  
Nine 79/100 Dollars ( \$45,569.79 ) for the  
improvement of said section from the municipality's allotment of Motor Fuel Tax funds.

3. That work shall be done by Day Labor ; and,  
Specify Contract or Day Labor

BE IT FURTHER RESOLVED, that the Clerk is hereby directed to transmit two certified copies of this resolution to the district office of the Department of Transportation.

<p>Approved</p> <hr/> <p>Date</p> <p>Department of Transportation</p> <hr/> <p>Regional Engineer</p>	<p>I, <u>Joanne Ragona</u> Clerk in and for the City of <u>Darien</u> City, Town or Village County of <u>Dupage</u>, hereby certify the foregoing to be a true, perfect and complete copy of a resolution adopted by the <u>Council</u> Council or President and Board of Trustees at a meeting on _____ Date IN TESTIMONY WHEREOF, I have hereunto set my hand and seal this _____ day of _____ (SEAL) _____ City, Town, or Village Clerk</p>
--	--



BE IT RESOLVED, by the Council of the City of Darien, Illinois that the following described street(s) be improved under the Illinois Highway Code:

Table with 4 columns: Name of Thoroughfare, Route, From, To. Row 1: N/A, empty, empty, empty.

BE IT FURTHER RESOLVED, 1. That the proposed improvement shall consist of Annual General Maintenance

and shall be constructed N/A wide and be designated as Section 14-00000-00-RF

2. That there is hereby appropriated the (additional Yes No) sum of Seventeen Thousand Four Hundred Forty 00/100 Dollars (\$17,440) for the improvement of said section from the municipality's allotment of Motor Fuel Tax funds.

3. That work shall be done by Day Labor; and, Specify Contract or Day Labor

BE IT FURTHER RESOLVED, that the Clerk is hereby directed to transmit two certified copies of this resolution to the district office of the Department of Transportation.

Approved, Date, Department of Transportation, Regional Engineer

I, Joanne Ragona Clerk in and for the City of Darien, County of Dupage, hereby certify the foregoing to be a true, perfect and complete copy of a resolution adopted by the Council at a meeting on IN TESTIMONY WHEREOF, I have hereunto set my hand and seal this day of (SEAL) City, Town, or Village Clerk

## City of Darien MFT Section Review Updated (8/2015)

---

### Construction Projects

Please forward Final City Share Invoices as appropriate and the close-out paperwork.

- ✚ **Section 05-00029-00-NW / C-91-010-06**
- ✚ **Section 14-00032-00-CH / C 91-317-14**
- ✚ **Section 14-00032-00-RS / C-91-317-14**

### IMRF Projects

#### Section 11-00000-00-RF (IMRF)

**(\$ 39,635.66 appropriated)**  
(\$ 39,635.66 authorized)

- Please submit the following:
  - **(BLR 13510) Final Report** –5 copies required.

#### Section 12-00000-00-RF (IMRF)

**\$ 40,727.59 Per MES**

**(\$ 0.00 appropriated)**  
(\$ 0.00 authorized)

- Please submit the following:
  - **(BLR 09111) Resolution** for Improvement for **\$ 40,727.59** - 3 copies required.

#### Section 13-00000-00-RF (IMRF)

**\$ 54,430.21 Per MES**

**(\$ 0.00 appropriated)**  
(\$ 0.00 authorized)

- Please submit the following:
  - **(BLR 09111) Resolution** for Improvement for **\$ 54,430.21** - 3 copies required.

#### Section 14-00000-00-RF (IMRF)

**\$ 67,440.00 Per MES**

**(\$ 50,000.00 appropriated)**  
(\$ 50,000.00 authorized)

- Please submit the following:
  - **(BLR 09111) Supplemental Resolution** for Improvement for **\$ 17,440.00** - 3 copies required.

### Maintenance Programs

#### Section 08-00000-00-GM

**\$ 393,499.02 per MES**

**(\$ 854,125.00 appropriated)**  
(\$ 779,125.00 authorized for maintenance)

- **HOLD for Compliance Review**

## City of Darien MFT Section Review Updated (8/2015)

---

### Section 09-00000-00-GM

\$ 646,320.79 per MES

\$ 75,000.00 per MES

**(\$ 693,700.00 appropriated)**

(\$ 246,700.00 authorized for maintenance)

(\$ 75,000.00 authorized for engineering)

➤ Please submit the following:

- **(BLR 14230) Supplemental Resolution** for Maintenance of Streets and Highways for \$ 17,412.09 - 3 copies required.
- **Finalized (BLR 14310) Municipal Maintenance Expenditure Statement** – 4 copies.

### Section 10-00000-00-GM

\$ 558,187.14 per MES

**(\$ 642,385.60 appropriated)**

(\$ 642,385.60 authorized for maintenance)

- **HOLD for Compliance Review**

### Section 11-00000-00-GM

\$ 537,289.94 per MES

**(\$ 533,043.90 appropriated)**

(\$ 493,387.21 authorized for maintenance)

➤ Please submit the following:

- **(BLR 14230) Supplemental Resolution** for Maintenance of Streets and Highways for \$ 4,246.04 - 3 copies required.

### Section 12-00000-00-GM

\$ 487,783.23 per MES

\$ 2,000.00 per MES

**(\$ 580,332.55 appropriated)**

(\$ 578,332.55 authorized for maintenance)

(\$ 2,000.00 authorized for engineering)

- **HOLD for Compliance Review**

### Section 13-00000-00-GM

\$ 493,563.14 per MES

**(\$ 487,095.00 appropriated)**

(\$ 487,095.00 authorized for maintenance)

➤ Please submit the following:

- **(BLR 14230) Supplemental Resolution** for Maintenance of Streets for \$ 6,468.14 - 3 copies required.
- **(BLR 09150) Request for Expenditure/Authorization of Motor Fuel Tax Funds** – for \$ 6,468.14 (copy attached) - 1 copy required.

### Section 14-00000-00-GM

\$ 736,600.86 per MES

**(\$ 670,992.75 appropriated)**

(\$ 670,992.75 authorized for maintenance)

➤ Please submit the following:

- **(BLR 14230) Supplemental Resolution** for Maintenance of Streets for \$ 45,569.79 - 3 copies required.



# City of Darien MFT Section Review Updated (8/2015)

**Section 15-00000-00-GM**

\$ 532,209.68 per MES

**(\$ 593,817.50 appropriated)**

(\$ 593,817.50 authorized for maintenance)

➤ Please submit the following:

- **Finalized (BLR 14310) Municipal Maintenance Expenditure Statement**– 4 copies required.

## HOLDING for Compliance Review

### Other Category - Agency Authorizations (AA)

The following disbursements were not able to be identified to an approved MFT project or are ineligible MFT disbursements. We are requesting the City to identify these expenditures to an approved MFT project.

Section #	Amount	Notes
04-00000-08-AA	\$ 127,356.19	Sidewalk Construction – D Land Construction
04-00000-10-AA	\$ 31,539.93	No information
05-00000-07-AA	\$ 133,310.28	Christopher Burke Eng. (see attached)
06-00000-05-AA	\$ 48,759.33	Tree Removal
Total	<b>\$ 340,965.73</b>	

- **If the City is unable to identify Agency Authorizations the unidentified disbursed amounts will be required to be reimbursed to the City's MFT Account with written notification sent to LR&S when the reimbursements are complete.**

**AGENDA MEMO**  
**Municipal Services Meeting**  
**August 24, 2015**

**ISSUE STATEMENT**

Approval of a resolution authorizing additional funding in the amount of \$30,000 for the purpose of sharing costs for construction items associated with the Street Lighting Project within limited locations of the 75<sup>th</sup> Street Corridor and the Cass Avenue Corridor.

**BACKGROUND/HISTORY**

The City Council approved an Intergovernmental Agreement with the County of Dupage on May 4, 2015 for the Street Lighting Project within limited locations of the 75<sup>th</sup> Street Corridor and the Cass Avenue Corridor. See attached agenda memo labeled as Attachment A for additional background.

On July 31, 2015 the Illinois Department of Transportation opened bids for the project. The lowest bid was \$709,215.40 and is over the engineer's estimate by approximately \$20,000. Staff had requested a copy of the bid tally and IDOT will not release the bid tally until the project is awarded. Telephone conversations with Fawad Aqueel, IDOT Federal Aid Coordinator, indicated that the following items were over the engineer's estimate:

Decorative Luminaires  
Underground Conduit

Pending bid results, there may be an opportunity for additional cost share funding through the CMAQ grant. Since the County is the lead agency for the project, the additional funding request will need to be submitted by the County. The City staff is further requesting a contingency in the amount of \$10,000 for construction due to potential unforeseen field conditions.

The County of Dupage and IDOT has requested of the City to respond by August 26, 2015 to proceed with the project. If the City does not respond by said date the project may be rejected by the proposed vendor and/or IDOT and would require a rebid. The construction for project could start as early as late September, pending IDOT protocols.

Attached is the proposed detailed funding schedule labeled as Attachment B. Please note, proposed savings have been identified from the Carlisle Bridge Project and have been applied to the 75<sup>th</sup> Street Lighting Project to cover the shortfall and a \$10,000 contingency. Below please see the proposed cost summary.

DESCRIPTION	BUDGET
75TH STREET STREET LIGHT PROJECT	\$238,000.00
REVISED CITY COST	\$305,547.00
SHORTFALL	(\$67,547.00)

Savings to cover shortfall are from Road Program and Carlisle Bridge Project

**STAFF RECOMMENDATION**

Approval of a resolution authorizing additional funding in the amount of \$30,000 for the purpose of sharing costs for construction items associated with the Street Lighting Project within limited locations of the 75<sup>th</sup> Street Corridor and the Cass Avenue Corridor.

**ALTERNATE CONSIDERATION**

As directed.

**DECISION MODE**

This item will be forwarded to a Special City Council Meeting scheduled for August 24, 2015 for formal approval.

CC:  SUPERINTENDENT  
 FOREMAN  
 WORKING QUOTES  
 OTHER

AGENDA MEMO  
 City Council Meeting  
 May 4, 2015

ISSUE STATEMENT

FILE

Approval of a resolution authorizing the Mayor to execute an Intergovernmental Agreement with the County of DuPage for the purpose of sharing costs for design and construction engineering, IDOT Letting and Construction for the Street Lighting Project within limited locations of the 75<sup>th</sup> Street Corridor and the Cass Avenue Corridor in an amount not to exceed \$275,588.64.

BACKGROUND/HISTORY

The City of Darien has jointly succeeded with the County of DuPage in securing an extension of the CMAQ funding for the 75<sup>th</sup> Street Reconstruction Project as it relates to the replacement of street lighting along certain segments of 75<sup>th</sup> Street and along Cass Avenue, see attached plan labeled as Attachment A. Please recall 30 street light poles were removed as part of the reconstruction project. The street lights are owned and were installed by the City in the 80's and per the Intergovernmental Agreement on file. The County was not required to replace the street lighting. The CMAQ funding allows for the replacement lighting, in kind, design construction and construction engineering at a local match of 20%. The City Council also recently authorized theme lighting at specific locations within the 75<sup>th</sup> Street and Cass Avenue corridors. The theme lighting is not grant eligible and will be funded by the City 100%.

In summary the scope of the project includes the following limits:

- 75<sup>th</sup> Street – Williams Street to Nantucket Drive
- Cass Avenue - Plainfield Road to approximately 500 feet north of 75<sup>th</sup> Street
- Plainfield Road - East and West of Cass Avenue approximately 250 feet in each direction

and is further detailed on the attached Estimate of Cost sheets labeled as Attachment B1 and B2:

- Concrete pole foundations
- Conduit
- Electrical Wire
- Lighting Controller and appurtenances
- 19 Decorative single mast arms-with theme lighting
- 5 Decorative double mast arms-with theme lighting
- 13 Aluminum single mast arms-Utilizing the poles that were removed
- 5 Aluminum double mast arms-Utilizing the poles that were removed
- Restoration-Concrete, bituminous and landscaping
- Construction Layout
- Construction Engineering

*ICET  
 I. Clean Energy Community Foundation*

75<sup>th</sup> Street Corridor and Cass Avenue Street Lighting Project

May 4, 2015

Page 2 of 10

The proposed time line allows for the engineering plans, IDOT Letting and construction to be completed by December 2015. Pending lead times for the fixtures and weather, the project may carry into Spring of 2016. Should the Project require completion in 2016, an additional Construction Engineering expense may be incurred in the amount approximately \$65,000 of which the City would be responsible for \$21,450.

Attachment C is the 75<sup>th</sup> Street Corridor and Cass Avenue Corridor Cost Summary. Since the budgeting of this item, DuPage County's engineering consultant for the project has updated the cost schedule and pricing for the fixtures has increased, see attached e-mail labeled as Attachment D. Pending the bid results, staff will bring this item back to the City Council should the Construction Cost exceed the City Share in the amount of \$218,345. Pending the bid results, should the Construction Cost exceed the amount of \$218,345 this item will be brought back to the City Council for further consideration including rejecting the bids. The Construction Engineering Cost is estimated not to exceed a City Share of \$30,585.34. A contingency in the amount of \$21,450 for Winter Construction Engineering is included in the event that the Project will carry into Spring of 2016. The total cost of the project including Engineering Contingency shall not exceed \$275,588.64.

Upon completion of the Project, the City will own and maintain the Street Lights per the conditions of the Permit labeled as Exhibit B.

Attached is a copy of the Intergovernmental Agreement (IGA) with DuPage County for the Plainfield Road Project, labeled as Exhibit A.

The Street Lighting Project would be funded from the following line item:

ACCOUNT NUMBER	ACCOUNT DESCRIPTION	FY 15-16 BUDGET	PROPOSED EXPENDITURE	PROPOSED BALANCE
25-35-4390	75 <sup>th</sup> Street Lighting Project	\$ 238,000	\$ 254,138.64	(\$16,138.64)
25-35-4390	75 <sup>th</sup> Street Lighting Project CONTINGENCY WINTER ENGINEERING	N/A	\$ 21,450.00	(\$21,450.00)
TOTALS		\$ 238,000	\$ 275,588.64	(\$37,588.64)

Pending bid results, product lead times and weather conditions, the Project could be \$37,588.64 over budget. The Capital Account fund balance would be in a position to absorb the cost if necessary.

**75<sup>th</sup> Street-Cass Avenue Street Lighting Project**

**May 4, 2015**

**Page 3**

**COMMITTEE RECOMMENDATION**

Approval of a resolution authorizing the execution of an Intergovernmental Agreement with the County of DuPage for the purpose of sharing costs for design and construction engineering, IDOT Letting and Construction for the Street Lighting Project within limited locations of the 75<sup>th</sup> Street Corridor and the Cass Avenue Corridor in an amount not to exceed \$275,588.64.

**ALTERNATE CONSIDERATION**

As directed.

**DECISION MODE**

This item will be forwarded to City Council on May 4, 2015 for formal approval.

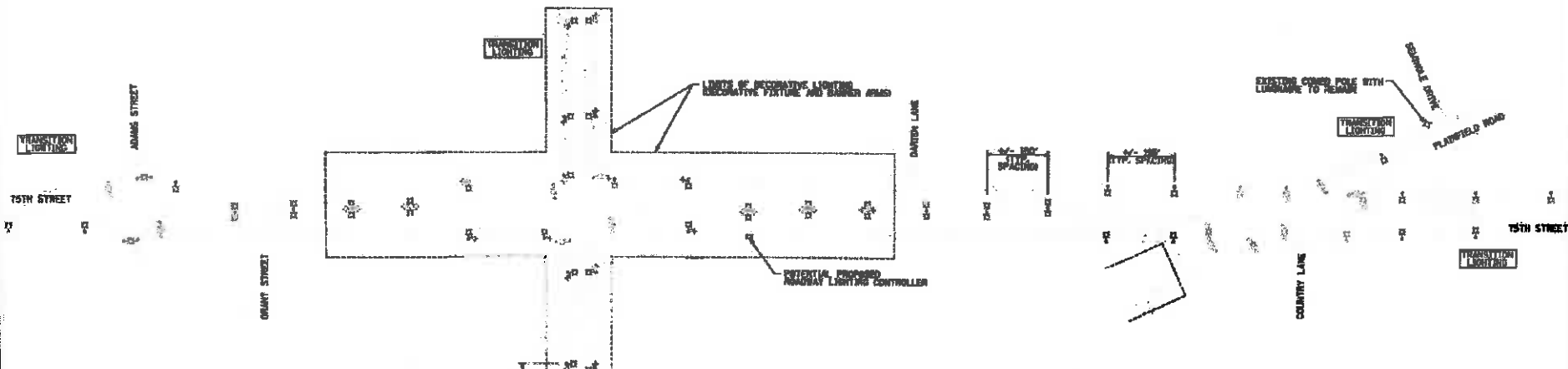

LEGEND OF LIGHTING SYMBOLS

SYMBOL	QUANTITY	DESCRIPTION
	10	<del>EXISTING ALTERNATE 600 PROPOSED ROADWAY LIGHTING. PROPOSED STREET LIGHT POLE GALVALUM, BLACK POWDER COAT FINISH WITH SINGLE L.E.D. ROADWAY LUMINAIRE, 42" MOUNTING HEIGHT, 32" MAST ARM SINGLE L.E.D. DECORATIVE FIXTURE, 20" MOUNTING HEIGHT, DECORATIVE SINGLE BANNER ARM, EXISTON FOUNDATION TO BE RETAINED</del>
	2	EXISTING ROADWAY LIGHTING POLE AND MAST ARM WITH PROPOSED L.E.D. ROADWAY LUMINAIRE INSTALLATION
	20	EXISTING COMBINATION TRAFFIC CONTROL POLE AND MAST ARM WITH PROPOSED L.E.D. ROADWAY LUMINAIRE INSTALLATION
	15	PROPOSED STREET LIGHT POLE GALVALUM, SATIN FINISH WITH SINGLE L.E.D. ROADWAY LUMINAIRE, 42" MOUNTING HEIGHT, 32" MAST ARM, DECORATIVE SINGLE BANNER ARM
	6	PROPOSED STREET LIGHT POLE GALVALUM, SATIN FINISH WITH DOUBLE L.E.D. ROADWAY LUMINAIRE, 42" MOUNTING HEIGHT, 32" MAST ARM, DECORATIVE DOUBLE BANNER ARM
	10	PROPOSED STREET LIGHT POLE GALVALUM, BLACK POWDER COAT FINISH WITH SINGLE L.E.D. ROADWAY LUMINAIRE, 42" MOUNTING HEIGHT, 32" MAST ARM SINGLE L.E.D. DECORATIVE FIXTURE, 20" MOUNTING HEIGHT, DECORATIVE SINGLE BANNER ARM
	6	PROPOSED STREET LIGHT POLE GALVALUM, BLACK POWDER COAT FINISH WITH DOUBLE L.E.D. ROADWAY LUMINAIRE, 42" MOUNTING HEIGHT, 32" MAST ARM DOUBLE L.E.D. DECORATIVE FIXTURE, 20" MOUNTING HEIGHT, DECORATIVE DOUBLE BANNER ARM

CALCULATED LIGHTING LEVELS

**INTERSECTION**

DESCRIPTION	CLASSIFICATION	Foot Candle	Foot Candle
REQUIRED LEVELS	ROADWAY	1.00	1.00
	PEDESTRIAN	0.50	0.50
	BIASION	2.20	3.00
	BIASION	2.20	3.00
	BIASION	2.20	3.00
	BIASION	2.20	3.00
	BIASION	2.20	3.00
	BIASION	2.20	3.00
	BIASION	2.20	3.00
	BIASION	2.20	3.00

**ROADWAY**

DESCRIPTION	CLASSIFICATION	Foot Candle	Foot Candle	Foot Candle	Foot Candle
REQUIRED LEVELS	ROADWAY	0.50	0.50	0.50	0.50
	PEDESTRIAN	0.50	0.50	0.50	0.50
	BIASION	0.50	0.50	0.50	0.50
	BIASION	0.50	0.50	0.50	0.50
	BIASION	0.50	0.50	0.50	0.50
	BIASION	0.50	0.50	0.50	0.50
	BIASION	0.50	0.50	0.50	0.50
	BIASION	0.50	0.50	0.50	0.50
	BIASION	0.50	0.50	0.50	0.50
	BIASION	0.50	0.50	0.50	0.50

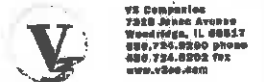

75TH STREET LIGHTING IMPROVEMENTS

DARLEM, ILLINOIS

DUPAGE COUNTY

CONCEPTUAL LIGHTING LAYOUT

DATE: 01-18-15



SCALE 1" = 200'

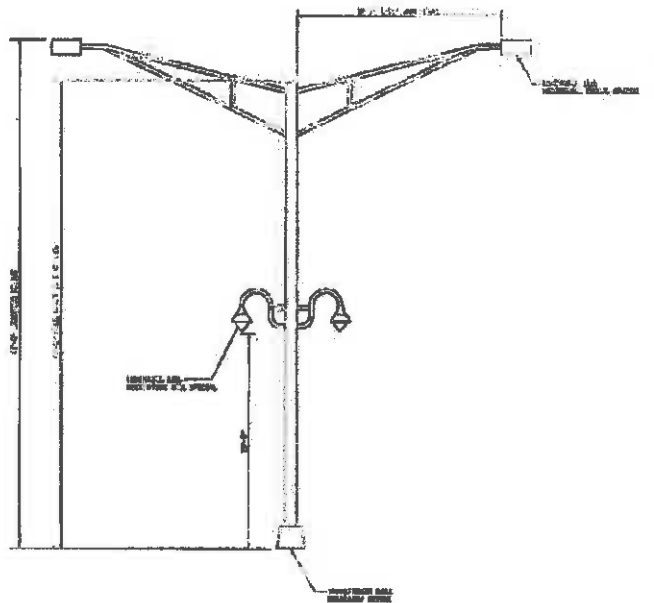
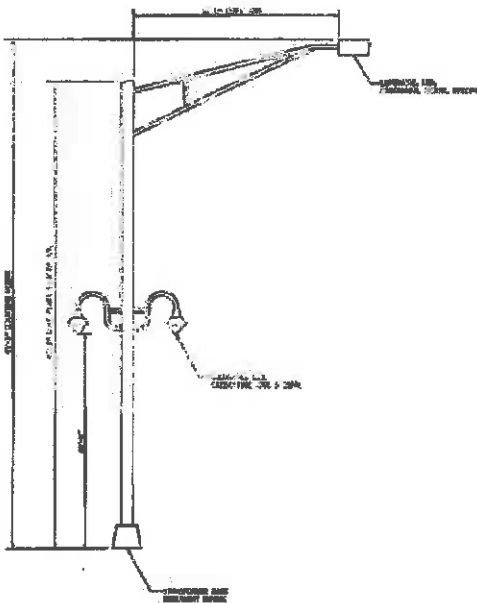

SEE SPECIFICATIONS FOR MATERIALS TO BE USED IN THE CONSTRUCTION OF THIS LIGHT POLE.

SEE SPECIFICATIONS FOR MATERIALS TO BE USED IN THE CONSTRUCTION OF THIS LIGHT POLE.

SEE SUFFOLK COUNTY COMMERCIAL STREET LIGHT DETAIL ON DRAWING 20 FOR ADDITIONAL LIGHT POLE INFORMATION.



DESIGNED BY	DATE	SCALE	PROJECT
DRAWN BY	DATE	SCALE	PROJECT
CHECKED BY	DATE	SCALE	PROJECT
APPROVED BY	DATE	SCALE	PROJECT

COUNTY OF MIDDLESEX  
DEPARTMENT OF PUBLIC WORKS

MIDDLESEX ALSO MAINTAINS SIGNALS  
SIGNALS AND SIGNALING SYSTEMS

NO.	REVISION	DATE	BY
1	ISSUED	10-15-14	...





Route 75th Street  
 County DuPage  
 Local Agency City of Darien  
 Section 12-00233-07-R

(Construction) Estimate of Cost

Location and brief description (Sta. and tent description of beginning; Sta. only for and for county and road districts; street limits for municipality.)  
Lighting enhancements on 75th Street from S. Adams Street to Plainfield Road and Cass Avenue from Plainfield Road to 75th Street.  
Improvements to include installation of LED street lighting fixtures, decorative lighting fixtures and poles and restrictions.

Total Project Length	10.824
Net Length	10.804

Surface Type	Asphalt
Width	Varies

Shoulder Type	C&G
Width	N/A

Length	
Width	

Item Number	Item	Unit	Quantity	Unit Price	Total Cost	EBD % Breakdown	
CARRIED FORWARD							
20201200	REMOVAL AND DISPOSAL OF UNSUITABLE MATERIAL	CU YD	25.0	\$ 30.00	\$ 750.00	0.11%	
35101502	AGGREGATE BASE COURSE, TYPE B 2"	SQ YD	11.0	\$ 8.00	\$ 88.00	0.01%	
35101800	AGGREGATE BASE COURSE, TYPE B 6"	SQ YD	11.0	\$ 10.00	\$ 110.00	0.02%	
40603335	HOT-MIX ASPHALT SURFACE COURSE, MIX "D", N50	TON	3.0	\$ 125.00	\$ 375.00	0.06%	
42400200	PORTLAND CEMENT CONCRETE SIDEWALK 6 INCH	SQ FT	100.0	\$ 10.00	\$ 1,000.00	0.15%	
44000500	SIDEWALK REMOVAL	SQ FT	100.0	\$ 8.00	\$ 800.00	0.12%	
66900200	NON-SPECIAL WASTE DISPOSAL	CU YD	16.0	\$ 85.00	\$ 1,360.00	0.21%	
66900530	SOIL DISPOSAL ANALYSIS	EACH	1.0	\$ 1.00	\$ 1.00	0.00%	
67100100	MOBILIZATION	LSUM	1.0	\$ 25,000.00	\$ 25,000.00	3.60%	
80400100	ELECTRIC SERVICE INSTALLATION	EACH	1.0	\$ 2,000.00	\$ 2,000.00	0.30%	
80400200	ELECTRIC UTILITY SERVICING CONNECTION	LSUM	1.0	\$ 15,000.00	\$ 15,000.00	2.26%	
81028220	UNDERGROUND CONDUIT, GALVANIZED STEEL, 3" DIA.	FOOT	3,635.0	\$ 23.00	\$ 83,805.00	12.64%	
81028740	UNDERGROUND CONDUIT, COILABLE NONMETALLIC CONDUIT, 1 1/2" DIA.	FOOT	1,082.0	\$ 8.00	\$ 8,736.00	1.33%	
81400100	HANDHOLE	EACH	6.0	\$ 1,000.00	\$ 6,000.00	0.91%	
81609078	UNIT DUCT, 600V, 3-1C NO.2, 1/C NO.2 GROUND, (P&P-TYPE USE), 1 1/2" DIA. POLYETHYLENE	FOOT	3,635.0	\$ 14.00	\$ 50,890.00	7.53%	
81609085	UNIT DUCT, 600V, 3-1C NO.4, 1/C NO.4 GROUND, (P&P-TYPE USE), 1 1/2" DIA. POLYETHYLENE	FOOT	9,100.0	\$ 12.60	\$ 114,660.00	16.81%	
81702160	ELECTRIC CABLE IN CONDUIT, 600V (P&P-TYPE USE) 1/C NO. 1/0	FOOT	60.0	\$ 8.00	\$ 480.00	0.07%	
82600350	LIGHTING CONTROLLER, BASE MOUNTED, 240VOLT, 100AMP	EACH	1.0	\$ 10,000.00	\$ 10,000.00	1.52%	
83050810	LIGHT POLE, ALUMINUM, 47.5 FT. M.H., 15 FT. MAST ARM	EACH	18.0	\$ 3,000.00	\$ 54,000.00	8.07%	
83060910	LIGHT POLE, ALUMINUM, 47.5 FT. M.H., 2-15 FT. MAST ARMS	EACH	6.0	\$ 3,200.00	\$ 19,200.00	2.83%	
<input checked="" type="checkbox"/> Page Total					<input type="checkbox"/> Total Estimated Cost	\$ 387,777.00	56.98%

Made by JWB  
 Checked by V.D.

Date 3/10/2015  
 Date 3/10/2015



Route 75th Street  
 County DuPage  
 Local Agency City of Dania  
 Section 12-C0233-07-A

(Construction) Estimate of Cost

Location and brief description (Site and kind description of beginning; Site only for road for county and road districts; street name for municipality.)  
Lighting enhancements on 75th Street from S. Adams Street to Plainfield Road and Cass Avenue from Plainfield Road to 75th Street.  
Improvements to include installation of LED street lighting fixtures, decorative lighting fixtures and poles and restoration.

Total Project Length	10.804'
Net Length	10.804'

Surface Type	Asphalt
Width	Varies

Shoulder Type	C&G
Width	N/A

Length	
Width	

Item Number	Name	Unit	Quantity	Unit Price	Total Cost	EEO % Breakdown	
CARRIED FORWARD						\$ 357,777.00	68.85%
85800200	LIGHT POLE FOUNDATION, 24" DIAMETER	FOOT	978.0	\$ 150.00	\$ 58,700.00	8.69%	
83800205	BREAKAWAY DEVICE, TRANSFORMER BASE, 15 INCH BOLT CIRCLE	EACH	42.0	\$ 100.00	\$ 4,200.00	0.84%	
84200800	REMOVAL OF LIGHTING UNIT, NO SALVAGE	EACH	1.0	\$ 250.00	\$ 250.00	0.04%	
84200804	REMOVAL OF POLE FOUNDATION	EACH	1.0	\$ 150.00	\$ 150.00	0.02%	
86000200	MAINTENANCE OF EXISTING TRAFFIC SIGNAL INSTALLATION	EACH	1.0	\$ 2,000.00	\$ 2,000.00	0.30%	
86502300	REMOVE ELECTRIC CABLE FROM CONDUIT	FOOT	753.0	\$ 0.75	\$ 562.50	0.09%	
X0328817	PAINTING LIGHT POLE UNIT	EACH	24.0	\$ 400.00	\$ 9,600.00	1.48%	
X0327038	BIKE PATH REMOVAL	SQ YD	11.0	\$ 8.00	\$ 88.00	0.01%	
X2130010	EXPLORATION TRENCH, SPECIAL	FOOT	100.0	\$ 20.00	\$ 2,000.00	0.30%	
X7010216	TRAFFIC CONTROL AND PROTECTION (SPECIAL)	LSUM	1.0	\$ 18,000.00	\$ 18,000.00	2.88%	
X0211125	LUMINAIRE, LED, HORIZONTAL MOUNT, SPECIAL	EACH	76.0	\$ 800.00	\$ 60,800.00	9.19%	
X3290215	LIGHT POLE FOUNDATION, 24" DIAMETER, OFFSET	FOOT	1.0	\$ 700.00	\$ 700.00	0.11%	
Z8013758	CONSTRUCTION LAYOUT	LSUM	1.0	\$ 13,000.00	\$ 13,000.00	1.98%	
	REMOVAL OF LUMINAIRE, SALVAGE	EACH	23.0	\$ 100.00	\$ 2,300.00	0.35%	
	LUMINAIRE, LED, DECORATIVE ARM, SPECIAL	EACH	48.0	\$ 1,800.00	\$ 86,400.00	13.14%	
	LIGHT POLE, ALUMINUM, 47.5 FT. M.H., 16 FT. MAST ARM (INSTALL ONLY)	EACH	13.0	\$ 700.00	\$ 9,100.00	1.38%	
	LIGHT POLE, ALUMINUM, 47.5 FT. M.H., 2-16 FT. MAST ARMS (INSTALL ONLY)	EACH	5.0	\$ 700.00	\$ 3,500.00	0.53%	
						Page Total	Total Estimated Cost
					\$ 657,327.50	100.00%	

Made by JWB  
 Checked by VJD

Date 3/10/2015  
 Date 3/10/2015

**7th Street Light Pole Installation and Lighting Enhancements**  
 City of Danim  
 7th Street (7400), Adams Street to Plainfield Road & Carr Avenue, Plainfield Road to 7th Street  
 Section No. 19-00000-07-L7  
 DePage County

Prepared By: VE Corporation  
 Date: 7/22  
 Sheet: VEB

**Estimated 2024 Impact of Cost**  
**Summary**

QUANTITY OF BIDDABLE	UNIT	TOTAL QTY	UNIT PRICE	CONTRACTOR'S COST		TOTAL COST	% LOCAL COST	% FEDERAL COST	% LOCAL CITY OF DANIM COST
				EST. LOCAL COST PER BIDDABLE UNIT	EST. FEDERAL COST PER BIDDABLE UNIT				
1	FOOT	1	100.00	100.00	0.00	100.00	0.00	0.00	0.00
42	EA	42	100.00	4200.00	0.00	4200.00	0.00	0.00	0.00
1	EA	1	100.00	100.00	0.00	100.00	0.00	0.00	0.00
1	EA	1	2,000.00	2000.00	0.00	2000.00	0.00	0.00	0.00
1	POST	1	100.00	100.00	0.00	100.00	0.00	0.00	0.00
24	EA	24	100.00	2400.00	0.00	2400.00	0.00	0.00	0.00
11	EA	11	100.00	1100.00	0.00	1100.00	0.00	0.00	0.00
100	FOOT	100	100.00	10000.00	0.00	10000.00	0.00	0.00	0.00
1	EA	1	10,000.00	10000.00	0.00	10000.00	0.00	0.00	0.00
96	EA	96	100.00	9600.00	0.00	9600.00	0.00	0.00	0.00
1	EA	1	100.00	100.00	0.00	100.00	0.00	0.00	0.00
1	EA	1	15,000.00	15000.00	0.00	15000.00	0.00	0.00	0.00
23	EA	23	100.00	2300.00	0.00	2300.00	0.00	0.00	0.00
42	EA	42	1,000.00	42000.00	0.00	42000.00	0.00	0.00	0.00
13	EA	13	100.00	1300.00	0.00	1300.00	0.00	0.00	0.00
8	EA	8	100.00	800.00	0.00	800.00	0.00	0.00	0.00

TOTAL CONSTRUCTION COST	\$	107,000.00	\$	107,000.00	\$	107,000.00
LOCAL TOTAL COSTS	\$	107,000.00	\$	107,000.00	\$	107,000.00
FEDERAL TOTAL COSTS	\$	0.00	\$	0.00	\$	0.00

75th Street High Pole Installation and Lighting Schematics  
 City of Duluth  
 13th Street (S100), Adams Street to Parkhill Road & Cass Avenue, Parkhill Road to 75th Street  
 Station No. 15-0299-07-LT  
 Duluth County

Prepared By: MS Thompson  
 Date: JFH  
 Check: VLB

Pre-Final BIDD Estimate of Cost  
 9/18/2016

ESTIMATE QUANTITY	UNIT	TOTAL QTY	UNIT PRICE	SUBTOTALS BY CATEGORY		TOTAL COST	DYS. FEDERAL COST	DYS. CITY OF DULUTH COST
				DYS. FEDERAL COST	DYS. CITY OF DULUTH COST			
2500000	REMOVAL AND DISPOSAL OF UNSURFACED ASPHALT	CU YD	21	\$ 80.00	25	\$ 1,680.00	\$ 780.00	\$ -
8800000	ADDRESS/PAVEMENT COURSE, TYPE 3 4"	SQ YD	11	\$ 8.00	11	\$ 88.00	\$ 0.00	\$ -
8800000	ADDRESS/PAVEMENT COURSE, TYPE 3 4"	SQ YD	11	\$ 8.00	11	\$ 88.00	\$ 0.00	\$ -
4000000	HOT/EMULSIFIED SURFACE COURSE, 5% YD, 1/2"	TON	5	\$ 23.00	5	\$ 115.00	\$ 0.00	\$ -
4000000	PORTLAND CEMENT CONCRETE SIDEWALK 4" 2200	SQ FT	100	\$ 10.00	100	\$ 1,000.00	\$ 1,000.00	\$ -
4000000	CONCRETE SIDEWALK	SQ FT	100	\$ 8.00	100	\$ 800.00	\$ 800.00	\$ -
8000000	NON-SPECIAL WASTE DISPOSAL	CU YD	16	\$ 66.00	16	\$ 1,056.00	\$ 1,056.00	\$ -
8000000	SOIL DISPOSAL ANALYSIS	BAG	1	\$ 1.00	1	\$ 1.00	\$ 1.00	\$ -
8000000	UTILIZATION	LOAD	1	\$ 20,000.00	1	\$ 20,000.00	\$ 20,000.00	\$ -
8000000	ELECTRIC SERVICE INSTALLATION	BAG	1	\$ 2,000.00	1	\$ 2,000.00	\$ 2,000.00	\$ -
8000000	ELECTRIC UTILITY SERVICES CONNECTION	LABOR	1	\$ 15,000.00	1	\$ 15,000.00	\$ 15,000.00	\$ -
8000000	UNDERGROUND CONDUIT, 2" UNARMED TYPE, 8' DIA.	FOOT	2,500	\$ 25.00	2,500	\$ 62,500.00	\$ 62,500.00	\$ -
8000000	UNDERGROUND CONDUIT, UNARMED POLYESTER/ALUMINUM 1 1/2" DIA.	FOOT	1,000	\$ 3.00	1,000	\$ 3,000.00	\$ 3,000.00	\$ -
8000000	CONDUIT	FOOT	5	\$ 1,000.00	5	\$ 5,000.00	\$ 5,000.00	\$ -
8000000	UNF. DUCT, 3/4" DIA., 1/2" WALL THICKNESS, OIL-TYPE RESIN, 1 1/2" DIA. POLYETHYLENE	FOOT	2,500	\$ 1.00	2,500	\$ 2,500.00	\$ 2,500.00	\$ -
8000000	UNF. DUCT, 3/4" DIA., 1/2" WALL THICKNESS, OIL-TYPE RESIN, 1 1/2" DIA. POLYETHYLENE	FOOT	2,500	\$ 1.00	2,500	\$ 2,500.00	\$ 2,500.00	\$ -
8000000	ELECTRIC CABLE IN CONDUIT, 600V OIL-TYPE USE 14/0 1A	FOOT	35	\$ 8.00	35	\$ 280.00	\$ 280.00	\$ -
8000000	GROUNDING CONDUCTOR, SAME COURSE, 250VOLT 100AMP	BAG	1	\$ 10,000.00	1	\$ 10,000.00	\$ 10,000.00	\$ -
8000000	1/2" POLY. ALUMINUM 4 1/2 FT DIA., 15 FT HANG ARM	BAG	10	\$ 3,000.00	10	\$ 30,000.00	\$ 30,000.00	\$ -
8000000	1/2" POLY. ALUMINUM 4 1/2 FT DIA., 8-10 FT HANG ARM	BAG	5	\$ 3,000.00	5	\$ 15,000.00	\$ 15,000.00	\$ -

Dan Gombac

**From:** Vince DelMedico <vdelmedico@v3co.com>  
**Sent:** Thursday, April 16, 2015 3:02 PM  
**To:** Dan Gombac  
**Cc:** Tworek, David (David.Tworek@dupageco.org); Jason Hoiv  
**Subject:** 75th Street Lighting Cost Estimate

Dan:

As a follow up to our conversation from earlier this week (with regard to the 75<sup>th</sup> Street Lighting pre-final cost estimate), V3 has gone back and taken another look at the estimated unit costs. Based on our review, we do not feel comfortable in reducing any of the suggested unit costs. We took the most in depth look at the decorative luminaire/arm cost (estimated at \$1800/each) and feel that it is appropriate based on the most recent conversations we have had with various lighting reps. Although V3 had initially estimated a unit cost of \$850 for this item, it was at the very early concept stage before we had an opportunity to discuss this item in detail with lighting reps. In addition, the initial cost had underestimated the cost associated with the decorative arm.

As another way to potentially reduce the overall project cost, the County is going to revisit the estimated construction engineering fee. Otherwise we may have to look at reducing the scope of the improvements proposed.

Please let me know if you have any questions. Thanks.

Vincent J. Del Medico, P.E.  
Senior Project Manager

**V3 Companies**

7325 James Avenue | Woodridge, IL 60517  
Direct: 630.724.6320 | Phone: 630.724.8200 | Fax: 630.724.8202 | Cell: 773.486.8831  
vdelmedico@v3co.com | www.v3co.com

V3 | THE VISION TO TRANSFORM WITH EXCELLENCE

 please consider the environment prior to printing

To receive important information from the City of Darien sign up for our electronic newsletter:

***DARIEN DIRECT CONNECT***

Follow the link below and subscribing is simple!

<http://www.darien.il.us/Departments/Administration/CityNews.html>

---

**From:** Dolan, Agnes [mailto:Agnes.Dolan@dupageco.org]

**Sent:** Friday, April 10, 2015 4:43 PM

**To:** Dan Gombac

**Cc:** Tworek, David; Krueger, Paul; Snyder, Christopher

**Subject:** IGA for Lighting Project - 75th Street

Dan,

Attached is a revised IGA based on the latest Estimate of Cost from the Pre-Final Plan submittal.

Also, per Dave Tworek:

1. The replacement of street lights on Plainfield Rd. (except at Cass) have been removed.
2. The banner arms have been deleted from the contract per Darien's request.
3. The decorative poles are not black, but actually a dark bronze.
4. The price of decorative lights were increased to \$1800 from the original estimate of \$850.
5. We will be re-using aluminum poles (removed before road construction) outside the commercial areas.

A copy of the latest Estimate of Cost is also attached hereto although I believe you have already received a copy from Dave or V3.

Exhibit B is also attached hereto/Permit conditions (see paragraph 7.2 added in agreement).

Please review the revised IGA and attachments herein and let me know if you have any comments so that we can work towards finalizing the agreement for execution. Please feel free to contact me or Dave if you should have any additional questions in your review of the revised IGA. Thank you.

**Agnes Dolan**

**Agreements Coordinator**

**DuPage County Division of Transportation**

**421 N. County Farm Road**

**Wheaton, IL 60187**

**Main: (630) 407-6900**

**Facsimile: (630) 407-6901**

**Direct: (630) 407-6896**

**A RESOLUTION AUTHORIZING THE MAYOR TO EXECUTE AN INTERGOVERNMENTAL AGREEMENT WITH THE COUNTY OF DUPAGE FOR THE PURPOSE OF SHARING COSTS FOR DESIGN AND CONSTRUCTION ENGINEERING, IDOT LETTING AND CONSTRUCTION FOR THE STREET LIGHTING PROJECT WITHIN LIMITED LOCATIONS OF THE 75<sup>TH</sup> STREET CORRIDOR AND THE CASS AVENUE CORRIDOR**

WHEREAS, under the Constitution and Statutes of the State of Illinois, a municipality is authorized to participate in intergovernmental cooperation; and

WHEREAS, The Corporate Authorities, for record keeping, desire to authorize the execution of the Intergovernmental Agreement by Resolution.

NOW, THEREFORE, BE IT RESOLVED BY THE CITY COUNCIL OF THE CITY OF DARIEN, DUPAGE COUNTY, as follows:

**SECTION 1:** That the Mayor is hereby authorized to execute an Intergovernmental Agreement (attached hereto as "Exhibit A") for the purpose of sharing costs for design and construction engineering, IDOT Letting and Construction for the Street Lighting Project within limited locations of the 75<sup>th</sup> Street corridor and the Cass Avenue corridor. The obligations of the City of Darien shall be limited to those specifically stated within the terms of the Intergovernmental Agreement.

**SECTION 2:** This Resolution shall be in full force and effect from and after its passage and approval as provided by law.

RESOLUTION NO. R-59-15

PASSED BY THE CITY COUNCIL OF THE CITY OF DARIEN, DUPAGE COUNTY, ILLINOIS, this 4th day of May, 2015.

AYES: 6 - Beilke, Belczak, Kenny, Marchese, McIvor, Schauer

NAYS: 0 - NONE

ABSENT: 0 - NONE

APPROVED BY THE MAYOR FOR THE CITY OF DARIEN, DUPAGE COUNTY, ILLINOIS, this 4<sup>th</sup> day of May, 2015.

Kathleen Moesle Weaver  
KATHLEEN MOESLE WEAVER, MAYOR

ATTEST:  
Joanne E. Ragona  
JOANNE E. RAGONA, CITY CLERK

APPROVED AS TO FORM:  
John B. Murphy, Jr.  
CITY ATTORNEY





INTERGOVERNMENTAL AGREEMENT BETWEEN THE  
COUNTY OF DU PAGE  
AND  
THE CITY OF DARIEN  
FOR  
STREET LIGHTING IMPROVEMENTS RELATING TO THE CONSTRUCTION OF  
COUNTY HIGHWAY 33/75<sup>TH</sup> STREET  
(ADAMS STREET TO PLAINFIELD ROAD)  
SECTION NO. 15-00233-07-LT

This Intergovernmental Agreement (hereinafter referred to as "AGREEMENT") is entered into this 9th day of June, 2015, between the County of DuPage (hereinafter referred to as the "COUNTY"), a body corporate and politic, with offices at 421 North County Farm Road, Wheaton, Illinois and the City of Darien (hereinafter referred to as the "CITY"), a municipal corporation with offices at 1702 Plainfield Road, Darien, Illinois. The COUNTY and the CITY are hereinafter sometimes individually referred to as a "party" or together as the "parties."

RECITALS

WHEREAS, the CITY in order to ensure the safety of the motoring public is desirous of replacing existing street lighting (hereinafter referred to as "STREET LIGHTING," Section 15-00233-07-LT) impacted by the construction of CH 33/75<sup>th</sup> Street, from Adams Street to Plainfield Road, County Section No. 12-00233-07-PV (hereinafter referred to as "PROJECT"); and

WHEREAS, the PROJECT is currently under construction and it has been determined that the STREET LIGHTING is eligible for federal Congestion Mitigation and Air Quality Improvement Program (CMAQ) funds currently obligated to the PROJECT; and

WHEREAS, CMAQ funds obligated for the PROJECT in excess of what is estimated to be necessary to complete the PROJECT can be redistributed to the STREET LIGHTING as a separate project; and

WHEREAS, the COUNTY's design consultant for the PROJECT has been directed to perform said STREET LIGHTING design work; and

WHEREAS, the COUNTY and the CITY desire to cooperate in the STREET LIGHTING because of the benefit of the STREETING

LIGHTING to the residents of DuPage County, the CITY and the public; and

WHEREAS, the COUNTY and the CITY desire to establish the parties' mutual project, cost and maintenance responsibilities with respect to the STREET LIGHTING; and

WHEREAS, the COUNTY by virtue of its power set forth in "Counties Code" (55 ILCS 5/1-1001 et seq.) and "Illinois Highway Code" (605 ILCS 5/1-101 et seq.) and the CITY by virtue of its power set forth in the "Illinois Municipal Code" (65 ILCS 5/1-1-1 et seq.) are authorized to enter into this AGREEMENT; and

WHEREAS, a cooperative intergovernmental agreement is appropriate and such an agreement is authorized and encouraged by Article 7, Section 10 of the Illinois Constitution and Intergovernmental Cooperation Act (5 ILCS 220/1 et seq.).

NOW, THEREFORE, in consideration of the premises, the mutual covenants, terms, and conditions herein set forth, and the understandings of each party to the other, the parties do hereby mutually covenant, promise and agree as follows:

#### **1.0 INCORPORATION.**

- 1.1. All recitals set forth above are incorporated herein and made part hereof, the same constituting the factual basis for this AGREEMENT.
- 1.2. The headings of the paragraphs and subparagraphs of this AGREEMENT are inserted for convenience of reference only and shall not be deemed to constitute part of this AGREEMENT or to affect the construction thereof.

#### **2.0 SCOPE OF STREET LIGHTING**

- 2.1. The STREET LIGHTING includes, but is not limited to, street lighting along 75<sup>th</sup> Street between Adams Street and Plainfield Road and along Cass Avenue from 75<sup>th</sup> Street to Plainfield Road.
- 2.2. The design of the STREET LIGHTING will include painting the light poles, decorative treatments and

new street lighting as requested by the CITY and subject to CITY cost share as noted herein below.

### **3.0 RESPONSIBILITIES - JOINT**

- 3.1. The COUNTY and CITY agree to cooperate in and make every effort to cause the construction of the STREET LIGHTING.
- 3.2. The COUNTY and the CITY agree that the estimated cost of the STREET LIGHTING that includes design, construction and construction engineering is \$776,048.96, and the CITY's share is \$254,138.64 as shown on Exhibit A attached hereto and incorporated herein by reference.
- 3.3. The COUNTY and CITY agree that the contract documents for the STREET LIGHTING will be prepared in an effort to minimize the need to relocate CITY utilities. Should field conditions result in unexpected utility conflict(s), reasonably demonstrated to be the result on the information provided to the COUNTY from the CITY, all reasonable costs associated with resolving said utility conflict(s) shall be at the sole cost of the CITY.
- 3.4. The COUNTY and the CITY acknowledge that no right-of-way is required for the STREET LIGHTING.

### **4.0 RESPONSIBILITIES OF THE COUNTY**

- 4.1. The COUNTY shall act as the lead agency and be responsible for completing all design engineering and coordination for a letting with IDOT as well as construction engineering for the STREET LIGHTING with reimbursement by the CITY as hereinafter referenced.
- 4.2. Both the COUNTY and CITY agree that the CITY reserves the right to request that IDOT not award the contract if the bid prices are unacceptable to the CITY for the STREET LIGHTING.
- 4.3. Both the COUNTY and CITY agree that the COUNTY shall administer the contract for the construction of the STREET LIGHTING. The COUNTY agrees to administer the STREET LIGHTING contract in the best interest of both

parties and to consult with, and keep advised, officials of the CITY regarding the progress of the STREET LIGHTING and any problems encountered or changes recommended. No change order which affects the CITY's facilities, or CITY cost, except normal minor variations in quantities of pay items required to complete the STREET LIGHTING shall be authorized except with prior written or e-mail approval by the CITY.

- 4.4. The COUNTY shall submit the Pre-final Plans and Specifications for the STREET LIGHTING to the CITY for review. The CITY shall provide review comments within fourteen (14) days of receipt of the Pre-final Plans and Specifications. The COUNTY will correct any errors and address other reasonable comments prior to the submittal of Final Plans and Specifications to the CITY.

#### **5.0 RESPONSIBILITIES OF THE CITY**

- 5.1. The CITY shall immediately notify the COUNTY, in writing, if the bid is unacceptable to the CITY for the STREET LIGHTING and shall inform the COUNTY to reject the bid.
- 5.2. The CITY shall, upon completion and acceptance of the STREET LIGHTING own, operate, and maintain the STREET LIGHTING and be financially responsible to repair, relocate, and replace the STREET LIGHTING, if necessary, due to future roadway improvements. Acceptance of the STREET LIGHTING shall not be unreasonably withheld by the CITY.
- 5.3. The CITY also agrees that upon completion and acceptance of the STREET LIGHTING, the CITY shall assume all future energy costs for the STREET LIGHTING and will be invoiced directly by the energy provider. The parties acknowledge that the STREET LIGHTING is separate from the COUNTY's combination poles at signalized intersections within the PROJECT.
- 5.4. The CITY shall assign a representative to the STREET LIGHTING construction to inspect the work and consult with the COUNTY or COUNTY's resident engineer on a regular basis.

5.5. The CITY agrees to reimburse the COUNTY for the 20% local match of the CMAQ funding for design engineering (or balance not covered by CMAQ), in addition to the CITY's share of costs for construction/construction engineering as shown on Exhibit A based upon actual construction bid costs plus the cost of any additional items required as a part of the STREET LIGHTING authorized in writing or via email by the CITY and the final construction engineering costs, less any federal shares. The CITY agrees to pay the COUNTY eighty (80%) percent of the Total Estimate of CITY's Cost as referenced on Exhibit A upon submittal of an invoice. Upon completion and acceptance by the CITY of the STREET LIGHTING and based upon the documentation of final costs and quantities, submitted by the COUNTY and a final invoice, the CITY agrees to reimburse the COUNTY for the balance of the STREET LIGHTING cost within sixty (60) days of receipt of a properly documented invoice from the COUNTY. The CITY agrees that any elements of the STREET LIGHTING requested by the CITY that are not CMAQ eligible will be at 100% CITY cost.

## 6.0 INDEMNIFICATION

6.1. The COUNTY shall to the extent permitted by law, indemnify, hold harmless and defend the CITY, its officials, officers, employees, and agents from and against all liability, claims, suits, demands, proceedings and action, including costs, fees and expense of defense, arising from, growing out of, or related to, any loss, damage, injury, death, or loss or damage to property resulting from, or connected with, the COUNTY's negligent or willful acts, errors or omissions in its performance under this AGREEMENT to the extent permitted by law. The COUNTY does not hereby waive any defenses or immunity available to it with respect to third parties.

6.1.1. The COUNTY and the CITY acknowledge that the COUNTY has made no representations, assurances or guaranties regarding the COUNTY's or any successor's or assign's authority and legal capacity to indemnify CITY as provided for in this AGREEMENT. In the event a court of

competent jurisdiction holds that the COUNTY, or any successor or assign, is deemed to lack the lawful authority or ability to indemnify, defend or hold harmless the CITY, or any person or entity claiming a right through CITY, or in the event of change in the laws of the State of Illinois governing COUNTY's or any successor's or assign's indemnification authority, such occurrence(s) shall not affect the validity and enforceability of the remainder of this AGREEMENT or the parties rights and obligations provided for therein.

- 6.2. The CITY shall indemnify, hold harmless and defend the COUNTY, its officials, officers, employees, and agents from and against all liability, claims, suits, demands, proceedings and action, including costs, fees and expense of defense, arising from, growing out of, or related to, any loss, damage, injury, death, or loss or damage to property resulting from, or connected with, the CITY'S negligent or willful acts, errors or omissions in its performance under this AGREEMENT to the extent permitted by law. The CITY does not hereby waive any defenses or immunity available to it with respect to third parties.
- 6.3. Nothing contained herein shall be construed as prohibiting the COUNTY, its officials, directors, officers, agents and employees, from defending through the selection and use of their own agents, attorneys and experts, any claims, suits, demands, proceedings and actions brought against them. Pursuant to Illinois law, 55 ILCS 5/3-9005, any attorney representing the COUNTY, under this paragraph or paragraph 6.1, who is not already an Assistant State's Attorney, is to be appointed a Special Assistant State's Attorney, as provided in 55 ILCS 5/3-9008. The COUNTY'S participation in its defense shall not remove CITY'S duty to indemnify, defend, and hold the COUNTY harmless, as set forth above.
- 6.4. Neither party waives, by these indemnity requirements, any defenses or protections under the Local Governmental and Governmental Employees Tort Immunity Act (745 ILCS 10/1 et seq.) or otherwise

available to it, or to the other party, under the law.

- 6.5. Any indemnity as provided in this AGREEMENT shall not be limited by reason of the enumeration of any insurance coverage herein provided. The CITY'S and COUNTY'S indemnification under Section 6.0 hereof shall terminate when the PROJECT is completed and the CITY assumes its maintenance responsibilities as set forth in Section 5.2 hereof.

## 7.0 GENERAL

- 7.1 It is understood and agreed by the parties hereto that this AGREEMENT is intended to address mutual STREET LIGHTING cost and maintenance responsibilities and improvements requested by the CITY and no changes to existing highways and appurtenances maintenance and/or jurisdiction are proposed.
- 7.2 The parties agree that this AGREEMENT shall serve in lieu of a separate DuPage County Division of Transportation permit for the STREET LIGHTING. By execution of this AGREEMENT, the CITY agrees to be bound by the Highway Permit Conditions, attached hereto as Exhibit B and made a part hereof, and the DuPage County Highway Rights-of-Way Permit and Fee Ordinance (ODT-0001A-06) incorporated herein by reference and amended from time to time including all insurance requirements as they exist on the date of the execution of this AGREEMENT by the COUNTY.
- 7.3 Whenever in this AGREEMENT, approval or review of either the COUNTY or CITY is provided for, said approval or review shall not be unreasonably delayed or withheld.
- 7.4 In the event of a dispute between the COUNTY and CITY representatives in the preparation of the Plans and Specifications, or changes thereto, or in carrying out the terms of this AGREEMENT, the County Engineer of the COUNTY and the City Administrator of the CITY shall meet and resolve the issue.
- 7.5 No later than fourteen (14) days after the execution of this AGREEMENT, each party shall designate a representative to the other party who shall serve as

the full time representative of said party during the carrying out of the construction of the STREET LIGHTING. Each representative shall have authority, on behalf of such party, to receive notices and make inspections relating to the work covered in this AGREEMENT. Representatives shall be readily available to the other party.

- 7.6 This AGREEMENT may be executed in two (2) or more counterparts, each of which shall be deemed an original and all of which shall be deemed one in the same instrument.

#### **8.0 ENTIRE AGREEMENT**

- 8.1 This AGREEMENT represents the entire AGREEMENT between the parties with respect to the STREET LIGHTING, and supersedes all previous communications or understandings whether oral or written.

#### **9.0 NOTICES**

- 9.1 Any notice required hereunder shall be deemed properly given to the party to be notified at the time it is personally delivered or mailed by certified mail, return receipt requested, postage prepaid, or sent by confirmed facsimile, to the party's address. The address of each party is as specified below; either party may change its address for receiving notices by giving notices thereof in compliance with the terms of this subsection.

City of Darien  
1702 Plainfield Road  
Darien, IL 60561  
ATTN: Bryon D. Vana, City Administrator  
Phone: 630.852.5000  
Facsimile: 630.852.4709

County of DuPage  
Division of Transportation  
ATTN: Christopher C. Snyder, P.E.  
Director of Transportation/County Engineer  
421 N. County Farm Road



Wheaton, IL 60187  
Phone: 630.407.6900  
Facsimile: 630.407.6901

**10.0 AMENDMENT, MODIFICATION OR TERMINATION OF THIS AGREEMENT**

10.1 No modification or amendment to this AGREEMENT shall be effective until approved by the parties in writing.

**11.0 ASSIGNMENT**

11.1 This AGREEMENT shall be binding upon and inure to the benefit of the parties hereto, their successors and assigns.

**12.0 GOVERNING LAW**

12.1. This AGREEMENT shall be governed by the laws of the State of Illinois as to both interpretation and performance.

12.2. The forum for resolving any disputes concerning the parties' respective performance, or failure to perform, under this AGREEMENT, shall be the Judicial Circuit Court for DuPage County.

**13.0 AUTHORITY TO EXECUTE/RELATIONSHIP**

13.1 The parties hereto have read and reviewed the terms of this AGREEMENT and by their signature as affixed below represent that the signing party has the authority to execute this AGREEMENT and that the parties intend to be bound by the terms and conditions contained herein.

13.2 This AGREEMENT shall not be deemed or construed to create an employment, joint venture, partnership or other agency relationship between the parties.

**14.0 SEVERABILITY**

14.1 In the event, any provision of this AGREEMENT is held to be unenforceable or invalid for any reason, the enforceability thereof shall not affect the remainder of the AGREEMENT. The remainder of this AGREEMENT shall be construed as if not containing the particular provision and shall continue in full force, effect, and enforceability, in accordance with its terms.

**15.0 FORCE MAJEURE**

15.1 Neither party shall be liable for any delay or non-performance of their obligations caused by any contingency beyond their control including but not limited to Acts of God, war, civil unrest, strikes, walkouts, fires or natural disasters.

IN WITNESS whereof, the parties set their hands and seals as of the date first written above.

COUNTY OF DU PAGE

CITY OF DARIEN

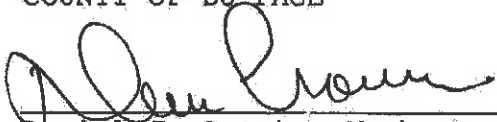
  
Daniel J. Cronin, Chairman  
DuPage County Board

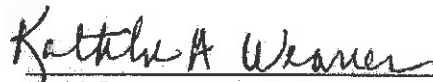
  
Kathleen A. Weaver, Mayor

ATTEST:

  
Paul Hinds  
County Clerk

  
Joanne E. Ragona  
City Clerk

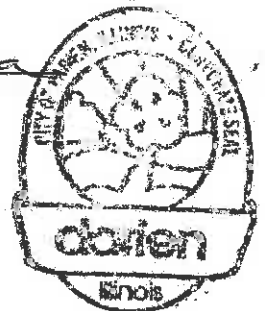

**EXHIBIT A  
ESTIMATE OF CITY COST**

Design engineering:	\$ 26,038.00	
20% Local Match for CMAQ eligible items (or balance thereof):		\$ 5,207.60
Estimated construction cost:	\$657,327.50	
20% Local Match for CMAQ eligible items:		\$109,745.50
100% differential cost for enhanced lighting features:		\$108,600.00
Estimated construction engineering:	\$92,683.46	
* CITY's share is estimated at 33%:		<u>\$ 30,585.54</u>
<b>TOTAL ESTIMATE OF CITY'S COST:</b>		<b>\$254,138.64</b>

\* If the STREET LIGHTING is delayed beyond the current anticipated schedule and additional construction engineering is required, the CITY's share of construction engineering will be adjusted. The CITY's share of the final total construction engineering cost will be the balance not covered by CMAQ funding.

EXHIBIT "A"

Page 1 Of 3

**75th Street Light Pole Installation and Lighting Enhancements**

City of Darren

75th Street (CR33), Adams Street to Plainfield Road & Cass Avenue, Plainfield Road to 75th Street

Section No. 15-00239-07-LT

DuPage County

Prepared By:

CWC:

Check:

V3 Companies

JWB

VJD

**Pre-Final (95%) Estimate of Cost**

2/10/2016

SUMMARY OF QUANTITIES				CONSTRUCTION TYPE CODE				TOTAL COST	50% FEDERAL / 25% CITY OF DARREN COST	50% CITY OF DARREN COST
	DESCRIPTION	UNIT	TOTAL QTY	UNIT PRICE	50% FEDERAL / 25% CITY OF DARREN LIGHTING	50% CITY OF DARREN NON-PARTICIPATING				
					0001	0002				
25201200	REMOVAL AND DISPOSAL OF UNSUITABLE MATERIAL	CU YD	25	\$ 36.00	25		\$ 750.00	\$ 750.00	\$ -	
35101302	AGGREGATE BASE COURSE, TYPE B 2"	SQ YD	11	\$ 8.00	11		\$ 88.00	\$ 88.00	\$ -	
35101230	AGGREGATE BASE COURSE, TYPE B 5"	SQ YD	11	\$ 10.00	11		\$ 110.00	\$ 110.00	\$ -	
40803533	HOT-MIX ASPHALT SURFACE COURSE, 1 1/2" TO 1 1/8"	TON	3	\$ 125.00	3		\$ 375.00	\$ 375.00	\$ -	
42402500	PORTLAND CEMENT CONCRETE SIDEWALK 8" DICH	SQ FT	100	\$ 16.00	100		\$ 1,600.00	\$ 1,600.00	\$ -	
44000600	SIDEWALK REMOVAL	SQ FT	100	\$ 8.25	100		\$ 825.00	\$ 825.00	\$ -	
68900200	NON-SPECIAL WASTE DISPOSAL	CU YD	16	\$ 66.00	16		\$ 1,056.00	\$ 1,056.00	\$ -	
69900530	SOIL DISPOSAL ANALYSIS	EACH	1	\$ 1.00	1		\$ 1.00	\$ 1.00	\$ -	
67100100	MOBILIZATION	LNUM	1	\$ 25,000.00	1		\$ 25,000.00	\$ 25,000.00	\$ -	
60400100	ELECTRIC SERVICE INSTALLATION	EACH	1	\$ 2,000.00	1		\$ 2,000.00	\$ 2,000.00	\$ -	
60400200	ELECTRIC UTILITY SERVICES CONNECTION	LNUM	1	\$ 15,000.00	1		\$ 15,000.00	\$ 15,000.00	\$ -	
61022220	UNDERGROUND CONDUIT, GALVANIZED STEEL, 2" DIA.	FOOT	3,659	\$ 23.00	3,659		\$ 84,257.00	\$ 84,257.00	\$ -	
61022740	UNDERGROUND CONDUIT, COLLABLE NONMETALLIC CONDUIT, 1 1/2" DIA.	FOOT	1,082	\$ 3.00	1,082		\$ 3,246.00	\$ 3,246.00	\$ -	
61400100	PIPHOLE	EACH	6	\$ 1,000.00	6		\$ 6,000.00	\$ 6,000.00	\$ -	
61800076	UNT DUCT, 60V, 3-10 NO. 2, 10 NO. 2 GROUND, (UL-TYPE USE), 1-1/2" DIA. POLYETHYLENE	FOOT	3,325	\$ 14.00	3,325		\$ 46,550.00	\$ 46,550.00	\$ -	
61800338	UNT DUCT, 60V, 3-10 NO. 4, 10 NO. 4 GROUND, (UL-TYPE USE), 1-1/4" DIA. POLYETHYLENE	FOOT	9,100	\$ 12.00	9,100		\$ 109,200.00	\$ 109,200.00	\$ -	
67702190	ELECTRIC CABLE (C) CONDUIT, 60V (UL-TYPE USE) 1/2" NO. 18	FOOT	60	\$ 5.00	60		\$ 300.00	\$ 300.00	\$ -	
62500850	LIGHTING CONTROLLER, BASE MOUNTED, 2" BUCKLE, 200AMP	EACH	1	\$ 10,000.00	1		\$ 10,000.00	\$ 10,000.00	\$ -	
63000810	LIGHT POLE, ALUMINUM, 47.5 FT. H.H., 15 FT. MAST ARM	EACH	19	\$ 3,000.00	19		\$ 57,000.00	\$ 57,000.00	\$ -	
63000810	LIGHT POLE, ALUMINUM, 47.5 FT. H.H., 2-15 FT. MAST ARMS	EACH	6	\$ 3,200.00	6		\$ 19,200.00	\$ 19,200.00	\$ -	

EXHIBIT "A"  
Page 2 of 3

**76th Street Light Pole Installation and Lighting Enhancements**

City of Danville

76th Street (CR33), Adams Street to Plainfield Road & Cass Avenue, Plainfield Road to 76th Street  
Section No. 15-04222-07-1.T  
DeWitt County

Prepared By:  
Date:  
Check:

VS Company  
JWS  
VJD

**Pre-Final (85%) Estimate of Cost**  
3/10/2016

SUMMARY OF QUANTITIES			UNIT	TOTAL QTY	UNIT PRICE	CONSTRUCTION TYPE CODE		TOTAL COST	80% FEDERAL / 20% CITY OF DANVILLE COST	100% CITY OF DANVILLE COST
						80% FEDERAL / 20% CITY OF DANVILLE	100% CITY OF DANVILLE			
						LIGHTING	LIGHTING			
8380020	LIGHT POLE FOUNDATION, 24" DIAMETER	FOOT	378	\$ 150.00	378		\$ 56,700.00	\$ 56,700.00	\$ -	
8380025	BREAKAWAY DEVICE, TRANSFORMER BASE, 1/2 INCH BOLT CIRCLE	EACH	42	\$ 100.00	42		\$ 4,200.00	\$ 4,200.00	\$ -	
8430000	REMOVAL OF LIGHTING UNIT, NO SALVAGE	EACH	1	\$ 250.00	1		\$ 250.00	\$ 250.00	\$ -	
8420004	REMOVAL OF POLE FOUNDATION	EACH	1	\$ 150.00	1		\$ 150.00	\$ 150.00	\$ -	
8860020	MAINTENANCE OF EXISTING TRAFFIC SIGNAL INSTALLATION	EACH	1	\$ 2,000.00	1		\$ 2,000.00	\$ 2,000.00	\$ -	
8860230	REMOVE ELECTRIC CABLE FROM CONDUIT	FOOT	750	\$ 0.78	750		\$ 585.00	\$ 585.00	\$ -	
3330847	PAINTING LIGHT POLE LINET	EACH	24	\$ 400.00		24	\$ 9,600.00	\$ -	\$ 9,600.00	
X022783	BIKE PATH REMOVAL	SQ YD	11	\$ 5.00	11		\$ 55.00	\$ 55.00	\$ -	
X010010	EXPLORATION TRENCH, SPECIAL	FOOT	100	\$ 20.00	100		\$ 2,000.00	\$ 2,000.00	\$ -	
X701023	TRAFFIC CONTROL AND PROTECTION (SPECIAL)	MIN	1	\$ 19,000.00	1		\$ 19,000.00	\$ 19,000.00	\$ -	
X021125	LUMINAIRE, LED, HORIZONTAL MOUNT, SPECIAL	EACH	75	\$ 800.00	75		\$ 60,000.00	\$ 60,000.00	\$ -	
X020025	LIGHT POLE FOUNDATION, 24" DIAMETER, OFFSET	FOOT	1	\$ 700.00	1		\$ 700.00	\$ 700.00	\$ -	
2201578	CONSTRUCTION LAYOUT	LSUR	1	\$ 13,000.00	1		\$ 13,000.00	\$ 13,000.00	\$ -	
	REMOVAL OF LUMINAIRE, SALVAGE	EACH	23	\$ 100.00	23		\$ 2,300.00	\$ 2,300.00	\$ -	
	LUMINAIRE, LED, BICOLOMATIVE ARM, SPECIAL	EACH	48	\$ 1,800.00		48	\$ 86,400.00	\$ -	\$ 86,400.00	
	LIGHT POLE, ALUMINUM, 47.5 FT. H.H., 15 FT. MAST ARM (INSTALL ONLY)	EACH	13	\$ 700.00		13	\$ 9,100.00	\$ -	\$ 9,100.00	
	LIGHT POLE, ALUMINUM, 47.5 FT. H.H., 2-15 FT. MAST ARMS (INSTALL ONLY)	EACH	5	\$ 700.00		5	\$ 3,500.00	\$ -	\$ 3,500.00	

TOTAL CONSTRUCTION COST	\$ 657,927.00	\$ 548,927.00	\$ 108,000.00
LOCAL TOTAL COSTS	\$ 216,345.00	\$ 108,245.00	\$ 108,100.00
FEDERAL TOTAL COSTS	\$ 441,582.00	\$ 440,682.00	\$ -



DuPage County  
DANIEL J. CRONIN  
COUNTY BOARD CHAIRMAN

DIVISION OF TRANSPORTATION

(630) 407-6900

FACSIMILE (630) 407-6901

EXHIBIT B PAGE 1 OF 3

PERMIT CONDITIONS:

1. Equipment and materials shall **NOT** be stored within the County's rights-of-way.
2. Existing sidewalk, curb/gutter and pavement disturbed or damaged due to the permitted work shall be replaced in kind as directed by the County Engineer, the duly authorized assign.
3. Pavement, curb/gutter and storm structures shall be maintained free of mud/debris at all times.
4. The Permittee, it's agent, successor, assign, and/or contractor shall furnish all material, labor, and pay all costs required to restore said County rights-of-way to a condition similar or equal to the conditions that existed before the commencement of the described work. It shall be the responsibility of the Permittee to properly grade, install a min. of 6" topsoil and seed (with erosion control blanket or hydro seeding) or sod (salt tolerant and staked in place) any portions of the rights-of-way disturbed during the described work.
5. Construction and erosion control measures shall comply with the minimum requirements of the "DuPage County Stormwater and Floodplain Ordinance" and any supplemental specifications made thereto.
6. The permitted improvements shall be located and constructed per the DuPage County standards and to the satisfaction of DuPage County Division of Transportation. The material used and method of construction shall comply with and conform to IDOT's "Standard Specifications for Road and Bridge Construction" (latest edition) and "Supplemental Specifications and Recurring Special Provisions" (latest edition).
7. The Permittee, it's agent, successor, assign, and/or contractor agrees to provide traffic control with advance warning signs, an arrow board and barricades conforming to the FHWA's "Manual on Uniform Traffic Control Devices" and IDOT's Highway Standards, "Standard Specifications for Road and Bridge Construction" (latest edition) and "Supplemental Specifications and Recurring Special Provisions" (latest edition) or as specified. The Permittee, it's agent, successor, assign, and/or contractor agrees to provide controlled flow of traffic at all times by approved detour or flag persons (with applicable warning signage) to minimize the inconvenience to traffic. Daily lane closures of County roadways are permitted Monday through Friday between 9:00 a.m. and 4:00 p.m. **ONLY**.
8. The Permittee, it's agent, successor, assign, and/or contractor assumes all risk and liability and agrees to defend, indemnify, and hold harmless the County of DuPage, its successors, assigns or employees, for any injury incurred to persons and/or damage to property in conjunction with and/or due to the permitted work/event.
9. The Permittee, it's agent, successor, assign, and/or contractor shall not trim, remove, or in any way disturb trees or shrubs along and/or within the highway or trail system rights-of-way without prior written approval by or from the DuPage County Division of Transportation.
10. The Permittee, it's agent, successor, assign, and/or contractor shall properly maintain all existing regulatory, warning and/or informational traffic control signage and/or devices along or within the DuPage County rights-of-way within the limits of the work covered under the permit and for the duration of said event permitted work/event. The DuPage County Division of Transportation shall be notified prior to construction and/or potential conflicts with existing signage due to the permitted construction. The Permittee, it's agent, successor, assign, and/or contractor furthermore shall reimburse the DuPage County Highway Maintenance Dept. for any relocation and/or replacement of, due to conflicts with and/or damage to, said signage, posts and/or equipment.
11. DuPage County reserves the right to make changes, additions and/or repairs to and relocations of, within its statutory limits, the facilities and/or their appurtenances constructed under this permit within the County rights-of-way as may at any time be considered necessary to permit the relocation, reconstruction, widening and/or maintaining of the highway, trail and/or path and/or to provide proper protection to life and property on or adjacent to the County rights-of-way. However, in the event this permit is granted to construct, locate, operate and/or maintain facilities on and/or within the County rights-of-way, the Permittee, it's agent, successor, assign, and/or contractor upon written notification from the County Engineer to the Permittee, shall perform such alterations or change of location of the facilities, solely at the permittee's cost as far as statutory authority dictates, without expense to DuPage County. Should the Permittee fail to make satisfactory arrangements to comply with said request within a reasonable time, DuPage County reserves the right to make such alterations to, change of location of and/or remove the facilities, and the Permittee, furthermore, shall pay for any costs incurred by DuPage County for said work.
12. The Permittee, it's agent, successor, assign, and/or contractor shall notify the DuPage County Division of Transportation a minimum of 48 hours prior to the start of construction, to arrange for any inspections and at the completion of the described work according to County procedures and/or policy.
13. The Permittee, it's agent, successor, assign, and/or contractor shall contact J.U.L.I.E. (1-800-892-0123) for utility locations a min. of 48 hours prior to the start of construction.
14. The Permittee, it's agent, successor, assign, and/or contractor agrees to reimburse the County for any costs incurred by DuPage County for any repair, relocation and/or adjustment to the traffic signals and related equipment that is in conflict with or is damaged due to the permitted work. All construction shall be coordinated with the County's Signal Coordinator. Contact the Division of Transportation pertaining to traffic signal related equipment at (630) 407-6900 a minimum of 48 hours prior to the start of construction to coordinate inspections.
15. The Permittee, it's agent, successor, assign, and/or contractor is required to contact the local agencies (including, but not limited to, municipal fire and police departments and the DuPage County Sheriff's Department) notifying them of all roadway construction or special event and traffic restrictions and/or temporary detours a minimum of 72 hours prior to the start of said construction/event.

PERMIT CONDITIONS:

Trench backfill for any excavation(s) shall be installed within the County rights-of-way per the attached County standard.

Open cutting of the roadway pavement is NOT permitted without the express written permission of the County Engineer or the duly authorized assign.

Contact the DuPage County Division of Transportation (630/407-6900) a minimum of 48 hours prior to the start of construction within ANY County right-of-way and within 300' on any side street adjacent to a County signalized highway intersection to request a location of the traffic signals and related equipment, including signal interconnection conduit/cable. The County's traffic signals and related equipment are NOT on the J.U.L.I.E. system.

**LANE CLOSURES ARE NOT PERMITTED ON COUNTY ROADWAYS DURING SNOWFALL OR WITHIN 2 HOURS PRIOR TO PREDICTED SNOWFALL OR PRECIPITATION CONDITIONS BETWEEN NOVEMBER 15 AND APRIL 15 FOR MAINTENANCE OF THE ROADWAY PAVEMENT BY COUNTY HIGHWAY MAINTENANCE DEPARTMENT STAFF AND EQUIPMENT.**

The Permittee, it's agent, successor, assign, and/or contractor agrees to provide as-built 'Record Drawings' of all improvements within and 100' adjacent to the County's rights-of-way to the County in a digital format (compatible with the County's AutoCAD system) upon their completion.

The Permittee, it's agent, successor, assign, and/or contractor agrees to assume sole responsibility for the maintenance of and liability for the permitted installation/construction.

The Permittee, it's agent, successor, assign, and/or contractor agrees to adjust, modify, relocate or remove the permitted items within sixty- (60) days of receipt of written notification as directed by the County to the Permittee.

***\*This permit is perpetual and thus the conditions stated herein and attached to the permit are without expiration, regardless of release of the bond posted and/or permit and/or acceptance of the construction/installation as permitted.***

DUPAGE COUNTY DIVISION OF TRANSPORTATION  
TRENCH BACKFILL STANDARD IN NON-PAVED AREAS  
(PARKWAYS, ETC.)

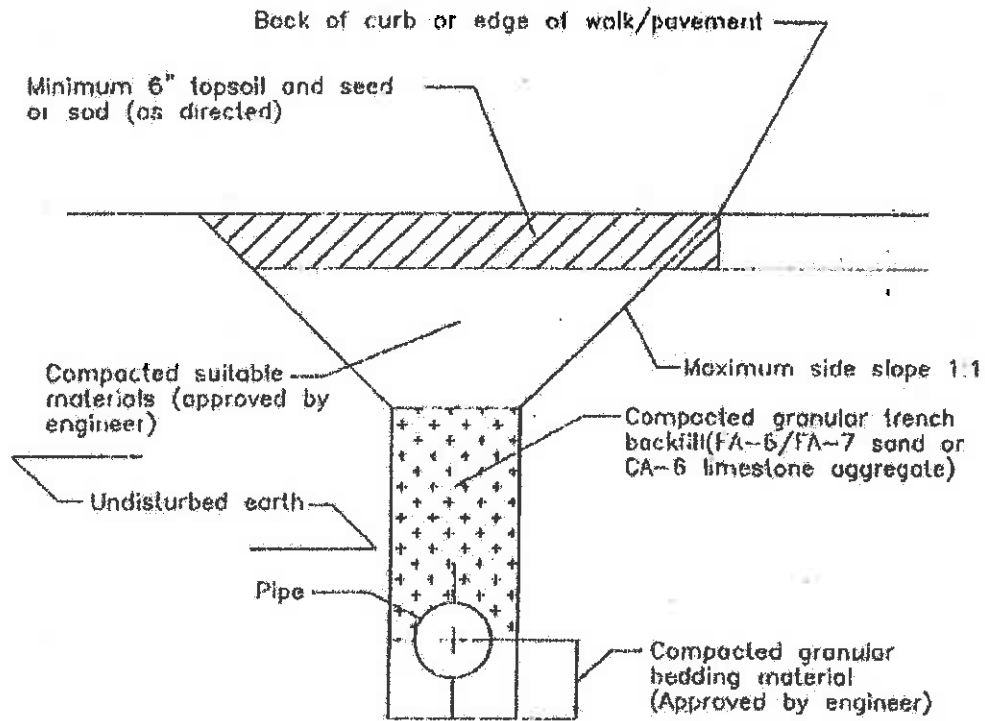

TOM H. 01-25-85  
M/NONPAVED.DWG





# CITY OF DARIEN

In the County of DuPage and the State of Illinois  
Incorporated 1969

May 7, 2015

Mr. Christopher Snyder  
DuPage County Division of Transportation  
421 North County Farm Road  
Wheaton, IL 60187

RE: 75<sup>th</sup> Street-Cass Avenue Street Lighting project

Dear Mr. Snyder:

Enclosed please a certified copy of *Resolution No. R-59-15 – “A RESOLUTION AUTHORIZING THE MAYOR TO EXECUTE AN INTERGOVERNMENTAL AGREEMENT WITH THE COUNTY OF DUPAGE FOR THE PURPOSE OF SHARING COSTS FOR DESIGN AND CONSTRUCTION ENGINEERING, IDOT LETTING AND CONSTRUCTION FOR THE STREET LIGHTING PROJECT WITHIN LIMITED LOCATIONS OF THE 75<sup>TH</sup> STREET CORRIDOR AND THE CASS AVENUE CORRIDOR”* passed by the City Council at its regular meeting on May 4, 2015.

Should you have any questions or concerns, please give me a call at (630) 353-8106.

Sincerely,  
CITY OF DARIEN

  
Daniel Gombac  
Director of Municipal Services

Enclosure

cc: JoAnne E. Ragona, City Clerk

Resolution

DT-R-0363-15

INTERGOVERNMENTAL AGREEMENT  
BETWEEN THE COUNTY OF DU PAGE, ILLINOIS  
AND THE CITY OF DARIEN  
FOR STREET LIGHTING IMPROVEMENTS ALONG  
CH 33/75<sup>TH</sup> STREET, FROM ADAMS STREET TO PLAINFIELD ROAD  
SECTION 15-00233-07-LT  
(COUNTY TO BE REIMBURSED 100% OF INCURRED COSTS)

WHEREAS, the County of DuPage (hereinafter referred to as COUNTY) and the City of Darien (hereinafter referred to as CITY) are public agencies within the meaning of the Illinois Intergovernmental Cooperation Act (5 ILCS 220/1 et seq.); and

WHEREAS, Article VII, Section 10, of the 1970 Constitution of the State of Illinois encourages and provides for units of local government to contract and otherwise associate with each other to exercise, combine or transfer any power or function; and

WHEREAS, the COUNTY by virtue of its power set forth in "Counties Code" (55 ILCS 5/1001 et seq.) and "Illinois Highway Code" (605 ILCS 5/1-101 et seq.) and the CITY by virtue of its power set forth in the "Illinois Municipal Code" (65 ILCS 5/1-1-1 et seq.) are authorized to enter into agreements and contracts; and

WHEREAS, in order to facilitate the free flow of traffic and to ensure the safety of the motoring public, the COUNTY and the CITY desire to improve CH 33/75<sup>th</sup> Street, from Adams Street to Plainfield Road, Section 15-00233-07-LT (hereinafter referred to as PROJECT); and

WHEREAS, an Intergovernmental Agreement has been prepared and is attached that outlines the rights and responsibilities of the COUNTY and the CITY related to the PROJECT; and

WHEREAS, the Agreement must be executed before the PROJECT may be initiated.

NOW, THEREFORE, BE IT RESOLVED by the DuPage County Board, that the Chairman and Clerk of said Board are hereby directed and authorized to execute the attached Intergovernmental Agreement with the CITY; and

BE IT FURTHER RESOLVED that three (3) original copies of this Resolution and Intergovernmental Agreement be sent to the CITY, by and through the Division of Transportation.

Enacted and approved this 9th day of June, 2015 at Wheaton, Illinois.

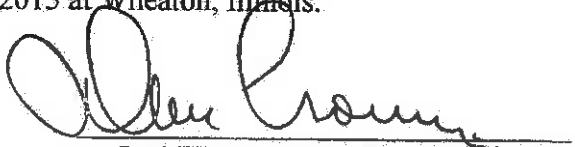
  
DANIEL J. CRONIN, CHAIRMAN  
DU PAGE COUNTY BOARD

Ayes: 16  
Absent: 2

Attest:   
PAUL HINDS, COUNTY CLERK

75<sup>th</sup> Street Corridor and Cass Avenue Corridor Cost Summary

DESCRIPTION	COSTS	FEDERAL SHARE	CITY SHARE
Design Engineering Cost	\$ 26,036.00	\$ 20,830.40	\$ 5,207.60
Estimated Construction Cost	\$ 657,327.50	\$ 438,982.00	
20% Local Match for CMAQ eligible items			\$ 109,745.50
100% Differential Cost for Traffic Lighting			\$ 108,600.00
Total Construction Costs	\$ 657,327.50	\$ 438,982.00	\$ 218,345.50
Estimated Construction Engineering	\$ 100,000.00	\$ 67,000.00	\$ 33,000.00
<b>Totals</b>	<b>\$ 733,365.50</b>	<b>\$ 526,812.40</b>	<b>\$ 256,553.10</b>
Contingency-Winter Engineering Costs	\$ 65,000.00	\$ 43,550.00	\$ 21,450.00
<b>Totals With Contingency</b>	<b>\$ 848,563.38</b>	<b>\$ 570,362.40</b>	<b>\$ 373,003.10</b>
City Budget FY15-16	\$ 292,000.00		
City Share Cost	\$ 256,553.10		
Contingency-Winter Engineering Costs	\$ 21,450.00		
<b>Budget Remainder</b>	<b>\$ (40,003.10)</b>		

**STREET LIGHTING 75TH STREET REVISED COST ESTIMATE 08-21-2015**

ACCOUNT NUMBER	PROJECT NUMBER	FY 15-16 BUDGET	DESCRIPTION	PROPOSED EXPENDITURE	PROPOSED SAVINGS	PROPOSED BALANCE
25-35-4390	FYE165103	\$ 238,000.00	75TH STREET STREET LIGHT PROJECT DESIGN ENGINEERING	\$ 5,207.60	N/A	\$ 232,792.40
25-35-4390	FYE165103	SEE ABOVE	75TH STREET STREET LIGHT PROJECT CONSTRUCTION	\$ 215,931.04	N/A	\$ 16,861.36
25-35-4376	FYE165004	\$ 184,000.00	CARLISLE BRIDGE	\$ 137,695.00	\$ 46,305.00	\$ 63,166.36
REVISED FUNDING LINE ITEM 25-35-4376	FYE165004 TO FYE165103	FROM CARLISLE BRIDGE SAVINGS	75TH STREET STREET LIGHT PROJECT MAY 4, 2015 CITY COUNCIL APPROVAL CARLISLE BRIDGE FUNDING TO COVER CONSTRUCTION ENGINEERING	\$ 33,000.00	N/A	\$ 30,166.36
REVISED FUNDING LINE ITEM 25-35-4376	FYE165004 TO FYE165103	FROM SAVINGS	75TH STREET STREET LIGHT PROJECT MAY 4, 2015 CITY COUNCIL APPROVAL CARLISLE BRIDGE FUNDING TO COVER WINTER ENGINEERING CONSTRUCTION CONTINGENCY	\$ 21,450.00	N/A	\$ 8,716.36
REVISED FUNDING LINE ITEM 25-35-4376	FYE167000 & FYE167001 TO FYE165103	FROM ROAD PROGRAM SAVINGS	ROAD PROGRAM FUNDING TO COVER REVISED CONSTRUCTION INCREASE	\$ 19,958.90	N/A	\$ (11,242.54)
REVISED FUNDING LINE ITEM 25-35-4376	FYE167000 & FYE167001 TO FYE165103	FROM ROAD PROGRAM SAVINGS	ROAD PROGRAM FUNDING TO COVER REVISED CONSTRUCTION CONTINGENCY	\$ 10,000.00	N/A	\$ (21,242.54)
REVISED FUNDING LINE ITEM 25-35-4855	FYE167000 & FYE167001	\$ 1,322,952.00	ROAD PROGRAM FUNDING TO COVER REVISED CONSTRUCTION INCREASE AND CONTINGENCY	\$ 1,280,000.00	\$ 42,952.00	\$ 21,709.46
TOTALS		\$ 1,744,952.00		\$ 1,723,242.54	\$ 21,709.46	
MAY 4, 2015 APPROVAL				\$ 275,588.64		
PROJECT COST INCREASE				\$ 29,958.90		
REVISED PROJECT COST WITH CONTINGENCY				\$ 305,547.54		
ENGINEERS ESTIMATE DATED APRIL 27, 2015				\$ 689,256.50		
BID OPENING RESULT DATED JULY 31, 2015				\$ 709,215.40		
DIFFERENCE				\$ (19,958.90)		

RESOLUTION NO. \_\_\_\_\_

**A RESOLUTION AUTHORIZING ADDITIONAL FUNDING IN THE AMOUNT OF \$30,000.00 FOR THE PURPOSE OF SHARING COSTS FOR CONSTRUCTION ITEMS ASSOCIATED WITH THE STREET LIGHTING PROJECT WITHIN LIMITED LOCATIONS OF THE 75<sup>TH</sup> STREET CORRIDOR AND THE CASS AVENUE CORRIDOR**

**BE IT RESOLVED BY THE CITY COUNCIL OF THE CITY OF DARIEN, DU PAGE COUNTY, ILLINOIS, as follows:**

**SECTION 1:** The City Council of the City of Darien hereby approves a resolution to authorize additional funding in the amount of \$30,000.00 for the purpose of sharing costs for construction items associated with the street lighting project within limited locations of the 75<sup>th</sup> Street Corridor and the Cass Avenue Corridor.

**SECTION 2:** This Resolution shall be in full force and effect from and after its passage and approval as provided by law.

**PASSED BY THE CITY COUNCIL OF THE CITY OF DARIEN, DU PAGE COUNTY, ILLINOIS, this 8th day of September, 2015.**

AYES: \_\_\_\_\_

NAYS: \_\_\_\_\_

ABSENT: \_\_\_\_\_

**APPROVED BY THE MAYOR OF THE CITY OF DARIEN, DU PAGE COUNTY, ILLINOIS, this 8th day of September, 2015.**

\_\_\_\_\_  
KATHLEEN MOESLE WEAVER, MAYOR

ATTEST:

\_\_\_\_\_  
JOANNE E. RAGONA, CITY CLERK

APPROVED AS TO FORM:

\_\_\_\_\_  
CITY ATTORNEY

**CITY OF DARIEN**  
**MUNICIPAL SERVICES COMMITTEE**  
**May 26, 2015**

**PRESENT:** Joseph Marchese - Chairperson, Alderman Tom Belczak, Dan Gombac – Director, Michael Griffith - Senior Planner, Elizabeth Lahey - Secretary

**ABSENT:** None

**OTHERS:** Mayor Kathy Weaver, Michael Coren

**ESTABLISH QUORUM**

Chairperson Marchese called the meeting of the Municipal Services Committee to order at 6:30 p.m. at the City Hall – City Council Chambers, Darien, Illinois and declared a quorum present.

**NEW BUSINESS**

- A. Ordinance - Darien Immediate Care, 8190 Cass Avenue - Petitioner seeks approval of a variation from the Sign Code to permit a wall sign on the side of the building which is not the front façade within the O Office Zoning District.**

Mr. Michael Griffith, Senior Planner reported the variation request is for the sign location and not for the size of the sign or illumination. He reported the PZC considered this matter and recommended approval 6-1. He further reported Chairperson Meyer voted against the petition and that there were comments against the petitioner as well.

Chairperson Marchese questioned if there was any other business with a sign on the side.

Mr. Griffith reported that there were no other businesses with a sign on the side. He stated that the request is for an Immediate Care Facility and that patients with emergencies are having a difficult time locating the facility. He reported the PZC felt that because of the nature of the business that there was justification for a sign.

Chairperson Marchese stated he was concerned if others in the office park would be requesting the same type of signage.

Mr. Griffith stated signs are allowed if they face the street. He stated if the property was zoned business they would not need a variation.

Alderman Belczak stated this was a unique situation and they will probably not see such a request again. He stated he cannot foresee why an office would need a variance.

Mr. Michael Coren, 8170 Cass Avenue stated his office building is immediately to the north. He provided some history of the development and stated the area was originally zoned for business but the developer asked the City to zone it office because of the homes in the area. Mr. Coren stated he was concerned for the variance because of aesthetics and that a precedent is being set. He further stated the PZC approved the variance for a certain circumstance and he is

at a significant financial disadvantage should a business want to add a sign. Mr. Coren stated if the City allows one to have a sign they should all be given the same.

Chairperson Marchese stated every situation is looked at individually and the task is to look at ways to help businesses. He stated he likes the look of the office park but he also wants to help out the business.

Alderman Belczak stated it is more to help those with an emergency and not so much the business.

Mr. Coren stated there are other urgent care facilities down the street and the petitioner should have done research beforehand.

Mr. Griffith reported that the Association does not object to a sign on Cass Avenue.

Mr. Dan Gombac, Director questioned the member of the Association.

Mr. Coren stated that each owner has one sixth vote.

There was no one else wishing to present public comment.

**Alderman Belczak made a motion, and it was seconded by Alderman Marchese to approve an Ordinance - Darien Immediate Care, 8190 Cass Avenue -a variation from the Sign Code to permit a wall sign on the side of the building which is not the front façade within the O Office Zoning District.**

**Upon voice vote, THE MOTION CARRIED unanimously 2-0.**

**B. 113 68th Street - Petitioner seeks approval of the following variations from the Zoning Ordinance in order to construct a new single-family home on an existing foundation: 1. To reduce the required front yard setback from 35 feet to 30.8 feet, 2. To reduce the required west interior side yard from 10 feet to 9.2 feet, within the R-2 Single Family Residence Zoning District.**

Mr. Michael Griffith, Senior Planner reported the petitioner's home was destroyed in a fire and the petitioner is proposing to build a new home on the existing foundation with a front porch. He reported the PZC held a public hearing and voted in favor of the petition. He further reported there were no comments or objections.

There was no one in the audience wishing to present public comment.

**Alderman Belczak made a motion, and it was seconded by Alderman Marchese approval of the following variations from the Zoning Ordinance in order to construct a new single-family home on an existing foundation: 1. To reduce the required front yard setback from 35 feet to 30.8 feet, 2. To reduce the required west interior side yard from 10 feet to 9.2 feet, within the R-2 Single Family Residence Zoning District.**

**Upon voice vote, THE MOTION CARRIED unanimously 2-0.**

**C. Discussion - Class D Liquor License - Amending the hours liquor can be served from a Class D Liquor License.**

Mr. Dan Gombac, Director reported that Chuck's Southern BBQ Café requested changing the hours of when liquor can be served. He reported on the hours of the businesses in the area and stated that staff surveyed adjacent communities as well. Mr. Gombac reported that amending the license affects all of the businesses holding the Class D Liquor License.

The petition stated that he would like to change the hours in order to accommodate the working class as well as for weddings or banquets to visit the bar afterwards.

Mayor Kathy Weaver stated that she was not in favor of it.

There was discussion about setting a precedent and the Committee discussed and felt a separate license was more appropriate.

The petitioner stated that he has a full service menu seven days a week.

Alderman Belczak stated that this was a unique entity and that he doesn't have a huge problem with the morning but had concern regarding the late night hours.

Mr. Gombac questioned the petitioner's motivation for the change of hours.

The petitioner stated that this would allow him more wiggle room to accommodate customers that have early hours instead of late hours. He further stated that the gaming is tied to the Liquor License and that he would hate to see people go somewhere else. The petitioner stated that his Burbank business has 7:00 a.m. and that he hardly sells any liquor.

Mayor Weaver stated that extensions are not favorable and that she has an issue with 3:00 a.m.

The petitioner stated that the late time is not the most important to him.

Mayor Weaver stated that a new license could be created to go along with the 7:00 a.m. request but not the 3:00 a.m. request.

Mr. Gombac stated that he was concerned that Dotty's would have to be addressed. He stated that he would look into who is serving breakfast.

Chairperson Marchese stated that if Dotty's is serving breakfast then they have the ability to ask for the same.

The Committee agreed to a separate license and that the recommendation would go to the City Council for discussion and then back to the Committee for approval.

Mr. Gombac reported that he received an email from Resident Joe Weber in opposition of any changes in the late hours and was amicable to the early hours.

Mr. Gombac reported that the Committee recommendation will be to propose early hours only. There was no one in the audience wishing to present public comment.



- D. Resolution – Accepting a proposal from Associated Technical Services (ATS) for the 2015 Water Leak Survey, in an amount of \$8,761.89 for the Leak Detection Phase and per unit cost for the Leak Location Phase in the amount of \$395.00 per mainline or service leak, and \$95.00 per fire hydrant leak or mainline valve for a total amount not to exceed \$14,700.00.**

Mr. Dan Gombac, Director reported that this is a proposal from Associated Technical Services (ATS) for the 2015 Water Leak Survey. He reported that ATS was the lowest competitive bid.

There was no one in the audience wishing to present public comment.

**Alderman Belczak made a motion, and it was seconded by Alderman Marchese to approve a Resolution accepting a proposal from Associated Technical Services (ATS) for the 2015 Water Leak Survey, in an amount of \$8,761.89 for the Leak Detection Phase and per unit cost for the Leak Location Phase in the amount of \$395.00 per mainline or service leak, and \$95.00 per fire hydrant leak or mainline valve for a total amount not to exceed \$14,700.00.**

**Upon voice vote, THE MOTION CARRIED unanimously 3-0.**

- E. Resolution - Authorizing the Mayor to accept a proposal from Superior Road Striping Co. in an amount not to exceed \$10,500.00 for the 2015 Road Striping Program.**

Mr. Dan Gombac, Director reported that is the awarded vendor for the Northwest Municipal Conference Joint Purchasing Cooperative for road striping to municipalities within the Midwest.

There was no one in the audience wishing to present public comment.

**Alderman Marchese made a motion, and it was seconded by Alderman Belczak to approve a Resolution authorizing the Mayor to accept a proposal from Superior Road Striping Co. in an amount not to exceed \$10,500.00 for the 2015 Road Striping Program.**

**Upon voice vote, THE MOTION CARRIED unanimously 2-0.**

- F. Resolution - Authorizing the purchase of six (6) various Steel Road Plates from Lee Jensen Sales Co. in an amount not to exceed \$10,360.00.**

Mr. Dan Gombac, Director reported that the road plates are used for excavating when a hole needs to temporarily be left open. He reported that it is better to own versus renting.

There was no one in the audience wishing to present public comment.

**Alderman Marchese made a motion, and it was seconded by Alderman Belczak to approve a Resolution authorizing the purchase of six (6) various Steel Road Plates from Lee Jensen Sales Co. in an amount not to exceed \$10,360.00.**

**Upon voice vote, THE MOTION CARRIED unanimously 2-0.**

**G. Resolution - Authorizing the purchase of an Aluminum Trench Box from Lee Jensen Sales Co. in the amount of \$6,500.00.**

Mr. Dan Gombac, Director reported that this is a safety related item. He reported that the pricing was negotiated.

There was no one in the audience wishing to present public comment.

**Alderman Belczak made a motion, and it was seconded by Alderman Marchese to approve a Resolution authorizing the purchase of an Aluminum Trench Box from Lee Jensen Sales Co. in the amount of \$6,500.00.**

**Upon voice vote, THE MOTION CARRIED unanimously 2-0.**

**H. Resolution - Accepting a proposal from United Septic, Inc. for Cleaning and Televising of Ironwood Avenue and Evergreen Lane Storm Sewer System in an amount not to exceed \$14,980 and Hourly Rate for Routine and Emergency Services for cleaning Storm Sewer Infrastructure in an amount not to exceed \$15,000 from May 2015-April 2016.**

Mr. Dan Gombac, Director reported that this is for the cleaning and televising of Ironwood Avenue and Evergreen Lane storm sewer system. The proposal also included an hourly rate for routine and emergency services for cleaning storm sewer infrastructure.

There was no one in the audience wishing to present public comment.

**Alderman Belczak made a motion, and it was seconded by Alderman Marchese to approve a Resolution accepting a proposal from United Septic, Inc. for Cleaning and Televising of Ironwood Avenue and Evergreen Lane Storm Sewer System in an amount not to exceed \$14,980 and Hourly Rate for Routine and Emergency Services for cleaning Storm Sewer Infrastructure in an amount not to exceed \$15,000 from May 2015-April 2016.**

**Upon voice vote, THE MOTION CARRIED unanimously 2-0.**

**I. Minutes - April 27, 2015 Municipal Services Committee**

**Alderman Marchese made a motion, and it was seconded by Alderman Belczak to approve the April 27, 2015 Municipal Services Committee Meeting Minutes.**

**Upon voice vote, THE MOTION CARRIED unanimously 2-0.**

**DIRECTOR'S REPORT**

None

**NEXT SCHEDULED MEETING**

Chairperson Marchese announced that the next regular meeting is scheduled for Monday, June 22, 2015 at 6:30 p.m.

**ADJOURNMENT**

**With no further business before the Committee, Alderman Belczak made a motion and it was seconded by Alderman Marchese to adjourn. Upon voice vote, THE MOTION CARRIED unanimously and the meeting adjourned at 7:40 p.m.**

**RESPECTFULLY SUBMITTED:**

---

**Joseph Marchese  
Chairman**

---

**Tom Belczak  
Alderman**

**CITY OF DARIEN**  
**MUNICIPAL SERVICES COMMITTEE**  
**June 22, 2015**

**PRESENT:** Joseph Marchese - Chairperson, Alderman Tom Belczak, Tom Chlystek, Dan Gombac – Director, Michael Griffith - Senior Planner, Elizabeth Lahey - Secretary

**ABSENT:** None

**ESTABLISH QUORUM**

Chairperson Marchese called the meeting of the Municipal Services Committee to order at 6:30 p.m. at the City Hall – City Council Chambers, Darien, Illinois and declared a quorum present.

**NEW BUSINESS**

**A. Ordinance - Minor PUD Amendment to the Darien Towne Centre PUD Amvets Collection Center at Wal-Mart, 2189 75th Street: Location Change.**

Mr. Dan Gombac, Director reported that the City Council granted a minor amendment to the PUD to allow an Amvets Collection Center to the west of Walmart. He reported that recently, Walmart required Amvets to move their collection center to the far northwest area of the parking lot to an underutilized area of the parking lot.

Mr. Gombac reported that staff tried to work with Walmart to an adjacent location as per the ordinance, but they were not in agreement. He stated that the proposed location is an out lot and the Darien Towne Center representatives were amicable to there were no problems or concerns for the out lot.

There was no one else wishing to present public comment.

**Alderman Belczak made a motion, and it was seconded by Alderman Chlystek to approve an Ordinance - Minor PUD Amendment to the Darien Towne Centre PUD Amvets Collection Center at Wal-Mart, 2189 75th Street: Location Change.**

**Upon voice vote, THE MOTION CARRIED unanimously 3-0.**

**B. Resolution - Authorizing the purchase of a Kubota Model ZD326P-60 zero turn riding mower from Russo Power Equipment Inc. in the amount of \$11,998.00.**

Mr. Dan Gombac, Director reported that this resolution authorizes the purchase of a turn riding mower to be utilized to maintain 33 acres of grass cutting and various right-of-ways. He reported that the 2006 Kubota would be declared surplus property and brought forward under a separate agenda memo.

There was no one in the audience wishing to present public comment.

**Alderman Belczak made a motion, and it was seconded by Alderman Marchese approval of a Resolution authorizing the purchase of a Kubota Model ZD326P-60 zero turn riding mower from Russo Power Equipment Inc. in the amount of \$11,998.00.**

**Upon voice vote, THE MOTION CARRIED unanimously 3-0.**

**C. Resolution - Allowing the City of Darien to perform maintenance and emergency work on City owned infrastructure on State of Illinois maintained Right-of-ways for 2015 and 2016.**

Mr. Dan Gombac, Director reported that this resolution is required by the State of Illinois and allows the City of Darien to perform maintenance and emergency work on City owned infrastructure on State of Illinois maintained right of ways right-of-ways for two years, 2015 and 2016.

There was no one in the audience wishing to present public comment.

**Alderman Belczak made a motion, and it was seconded by Alderman Chlystek approval of a Resolution allowing the City of Darien to perform maintenance and emergency work on City owned infrastructure on State of Illinois maintained Right-of-ways for 2015 and 2016.**

**Upon voice vote, THE MOTION CARRIED unanimously 3-0.**

**D. Resolution – Accepting a quote from Advanced Automation and Controls Inc. in an amount not to exceed \$14,070 for the following:**

**Item 1 - Updating of Water System Computer Hardware, Software and Programming - \$8,720.**

**Item 2 - Plant 2- Programming Logic Controller for Variable Speed Pumps - Hardware and Programming - \$5,350.**

Mr. Dan Gombac, Director reported that the existing computer and hardware was installed in 2008 operating on Windows XP which is no longer supported by Microsoft. He reported that the proposed purchase is for the computer hardware, software and programming. The system is a stand-alone system and is utilized to monitor and control the City's water system.

Mr. Gombac further reported that Item 2 is for updating the Supervisory Control and Data Acquisition (SCADA) system. The proposed Program Logic Controllers for the variable pumps will allow for optimal operation of the pumps. The improvement will allow for the pumps to operate at variable flow rates as the system demands. He reported that there will be additional cost saving opportunities as they relate to maintenance of equipment and energy.

Alderman Chlystek questioned staff is trained and if there is a warranty.

Mr. Gombac reported that there is a one-year warranty and the Water Plant Operators for the City are required to complete continue educating classes including SCADA operations.

There was no one in the audience wishing to present public comment.

**Alderman Chylstek made a motion, and it was seconded by Alderman Marchese to approve a Resolution accepting a quote from Advanced Automation and Controls Inc. in an amount not to exceed \$14,070 for the following:**

**Item 1 - Updating of Water System Computer Hardware, Software and Programming - \$8,720.**

**Item 2 - Plant 2-Programming Logic Controller for Variable Speed Pumps - Hardware and Programming - \$5,350.**

**Upon voice vote, THE MOTION CARRIED unanimously 3-0.**

**E. Resolution - Authorizing the Mayor to execute a contract with Patriot Pavement Maintenance Inc. in an amount not to exceed \$132,368 for the 2015 Crack Fill Program.**

Mr. Dan Gombac, Director reported that the resolution is for the 2015 Crack Fill Program. He reported that crack sealing is a routine maintenance treatment that delays roadway deterioration by sealing the water out of the pavement and base. Staff inventories the existing cracks approximately a year in advance and determines quantities for the crack seal program. The operation is completed on three year intervals or up to 9 years of treatment upon the resurfacing of a roadway. He further reported that severe winter conditions increases the cracks and adjusts the quantities to reflect the conditions.

Mr. Gombac reported that the references for Patriot Pavement were favorable.

There was no one in the audience wishing to present public comment.

**Alderman Belczak made a motion, and it was seconded by Alderman Chylstek to approve a Resolution authorizing the Mayor to execute a contract with Patriot Pavement Maintenance Inc. in an amount not to exceed \$132,368 for the 2015 Crack Fill Program.**

**Upon voice vote, THE MOTION CARRIED unanimously 3-0.**

### **DIRECTOR'S REPORT**

Mr. Dan Gombac, Director reported that the City and the Darien Park District were denied a recent grant for Birchwood Park. He reported that Speedway and Brookhaven are working on an agreement for a cross access agreement. He stated that this will create optimal convenience between the two businesses and that Speedway would incur all costs.

Mr. Gombac reported that Darien Pointe has contracted with an outside broker for retail tenant agreements. The developers have reported there are many inquiries and no commitments. He reported that the owner of the former Phillips 66 is working with a major coffee brand retailer.

Alderman Marchese stated that the owner for Darien Pointe is not doing much for prospective businesses regarding the build out.

Mr. Gombac stated that City staff continue to work with the potential tenants.

Mr. Gombac reported that staff has been trying to schedule the painting of the speakers at Darien Pointe but there is too much rain. He also reported that the road program is behind because of the weather as well.

**NEXT SCHEDULED MEETING**

Chairperson Marchese announced that the next regular meeting is scheduled for Monday, July 27, 2015 at 6:30 p.m.

**ADJOURNMENT**

**With no further business before the Committee, Alderman Belczak made a motion and it was seconded by Alderman Chlystek to adjourn. Upon voice vote, THE MOTION CARRIED unanimously and the meeting adjourned at 7:05 p.m.**

**RESPECTFULLY SUBMITTED:**

---

**Joseph Marchese  
Chairman**

---

**Tom Chlystek  
Alderman**

---

**Tom Belczak  
Alderman**