EXECUTIVE SESSION – 7:00 P.M.

- SALE OR LEASE OF REAL ESTATE SECTION 2(C)(5) &
- PERSONNEL SECTION 2(C)(1) OF THE OPEN MEETINGS ACT

PRE-COUNCIL WORK SESSION — 7:00 P.M.

Agenda of the Regular Meeting

of the City Council of the

CITY OF DARIEN

March 3, 2014

7:30 PM

1. Call to Order
2. Pledge of Allegiance
3. Roll Call
4. Declaration of Quorum
5. Questions, Comments and Announcements — General (This is an opportunity for the public to make comments or ask questions on any issue – **3 Minute Limit Per Person, Additional Public Comment Period - Agenda Item 18**).
6. Approval of Minutes — [February 18, 2014](#)
7. Receiving of Communications
8. Mayor's Report
 - A. Consideration of a Motion to Approve the [Reappointment of Members to the Planning and Zoning Commission: Donald Hickok and Susan Vonder Heide](#)
 - B. Consideration of a Motion to Approve the [Appointment of David Kesler to the Board of Fire and Police Commissioners](#)
 - C. Consideration of a Motion to Approve the [Reappointment of Frank Noverini to the Board of Fire and Police Commissioners](#)
9. City Clerk's Report
10. City Administrator's Report
11. Department Head Information/Questions
12. Treasurer's Report
 - A. Warrant Number — [13-14-20](#)
13. Standing Committee Reports
14. Questions and Comments — Agenda Related (This is an opportunity for the public to make comments or ask questions on any item on the Council's Agenda.)
15. Old Business
16. Consent Agenda
 - A. Consideration of a Motion to Approve [an Ordinance Authorizing the Sale of Personal Property Owned by the City of Darien](#) (Wireless Receiver, Transmitter, HP Laser Jet Printer, ipods and Misc. Items)
 - B. Consideration of a Motion to Approve [a Resolution Approving and Publishing the Updated City of Darien Official Zoning Map](#)
 - C. Consideration of a Motion to Approve an Ordinance Granting a One Year Extension to the Previously Approved Minor Amendment to an Approved Planned Unit Development ([Darien Towne Centre PUD, 2189 75th Street, Illinois, Amvets Collection Center at Wal-Mart](#))
 - D. Consideration of a Motion to Approve [a Resolution Accepting the Unit Price Proposal for Analytical Soil Testing Fees from Testing Services Corporation](#) at the Proposed Unit Prices for Certain Waste for a Period of May 1, 2014 through April 30, 2015
 - E. Consideration of a Motion to Approve [a Resolution Accepting a Proposal from Associated Technical Services \(ATS\)](#) for the 2013-14 Water Leak Survey in the Amount of \$8,288.28 for the Leak Detection Phase and a Per Unit Cost for the Leak Location Phase in the Amount of \$350.00 Per Mainline or Service Leak, and \$95.00 Per Fire Hydrant Leak or Mainline Valve for a Total Amount not to Exceed \$14,500
17. New Business
 - A. Consideration of a Motion to Approve [a Resolution Authorizing the City Administrator to Execute the First Amendment to Structure](#)

[Lease Agreement with General Communications](#) Dated May 16, 2013, to Allow General Communications to Locate a Wireless Dish Project on the Darien Water Tank located at 1220 Plainfield Road

- B. Consideration of a Motion [to Direct Staff to Propose City Code Amendments](#), 1. A Text Amendment to the Zoning Ordinance to List Medical Cannabis Cultivation and Dispensing Establishments as Special Uses in the I-1 General Industrial District, and 2. Addressing Medical Cannabis Possession
 - C. Consideration of a Motion to Approve [a Resolution Stating the Position of the Mayor and City Council Regarding the City of Darien's Funding of Crossing Guards](#) for School District 61
 - D. Consideration of a Motion to Approve [an Ordinance Amending Title 8 of the Darien City Code to Add a Chapter 23, "Crime-Free Residential Housing Requirements"](#)
18. Questions, Comments and Announcements — General (This is an opportunity for the public to make comments or ask questions on any issue.)
19. Adjournment

THERE WAS NO WORK SESSION.

**EXECUTIVE SESSION – SALE OR LEASE OF REAL ESTATE SECTION
2(C)(5) OF THE OPEN MEETINGS ACT**

It was moved by Alderman Marchese and seconded by Alderman Schauer to go into Executive Session for the purpose of discussion of Sale or Lease of Real Estate, Section 2(C)(5) of the Open Meetings Act at 7:09 P.M.

Roll Call: Ayes: Beilke, Belczak, Kenny, Marchese, McIvor,
Schauer, Seifert

Nays: None

Absent: None

Results: Ayes 7, Nays 0, Absent 0

MOTION DULY CARRIED

It was moved by Alderman McIvor and seconded by Alderman Beilke to adjourn Executive Session.

Roll Call: Ayes: Beilke, Belczak, Kenny, Marchese, McIvor,
Schauer, Seifert

Nays: None

Absent: None

Results: Ayes 7, Nays 0, Absent 0

MOTION DULY CARRIED

Executive Session was adjourned at 7:33 P.M.

Minutes of the Regular Meeting

of the City Council of the

CITY OF DARIEN

FEBRUARY 18, 2014

1. **CALL TO ORDER**

The regular meeting of the City Council of the City of Darien was called to order at 7:36 P.M. by Mayor Weaver.

2. **PLEDGE OF ALLEGIANCE**

Mayor Weaver led the Council and audience in the Pledge of Allegiance.

3. **ROLL CALL** — The Roll Call of Aldermen by Clerk Ragona was as follows:

Present:	Tina Beilke	Sylvia McIvor
	Thomas J. Belczak	Ted V. Schauer
	Joseph A. Kenny	Joerg Seifert
	Joseph A. Marchese	

Absent: None

Also in Attendance: Kathleen Moesle Weaver, Mayor
JoAnne E. Ragona, City Clerk
Michael J. Coren, City Treasurer
Bryon D. Vana, City Administrator
Scott Coren, Assistant City Administrator
Daniel Gombac, Director of Municipal Service
Ernest Brown, Police Chief

4. **DECLARATION OF A QUORUM** — There being seven aldermen present, Mayor Weaver declared a quorum.

5. **QUESTIONS, COMMENTS AND ANNOUNCEMENTS - GENERAL**

There were none.

6. **APPROVAL OF MINUTES** - February 3, 2014 City Council Meeting

It was moved by Alderman Schauer and seconded by Alderman Beilke to approve the minutes of the City Council Meeting of February 3, 2014 as presented.

Roll Call: Ayes: Beilke, Belczak, Kenny, Marchese, Schauer, Seifert
 Abstain: McIvor
 Nays: None
 Absent: None

Results: Ayes 7, Nays 0, Absent 0

MOTION DULY CARRIED

7. **RECEIVING OF COMMUNICATIONS**

Mayor Weaver advised that she received several compliments on the snowplowing efforts, and extended her own appreciation to the hard working staff of Public Works.

Alderman Marchese...

...advised that he has been told Darien snowplowing efforts are far superior to those in Downers Grove.

...received an e-mail from Jim Sims thanking Director Gombac for addressing a snow issue on the pathway near his home.

Administrator Vana advised that several complimentary e-mails regarding snow removal have been received. In addition to the snowplowing efforts, he wanted to recognize the fine work of Public Works in dealing with the numerous water main breaks this season.

Alderman Kenny received a complaint from Janet Kolodrovic of 1730 Gigi regarding an unplowed street which was plowed before he was able to inspect it.

Mayor Weaver announced that DuPage County Division of Transportation will be hosting an informational Open House to review the improvements to be constructed along 75th Street from Adams Street to Plainfield Road. It will be held at Ashton Place in Willowbrook on February 27, 2014 from 4:00 to 7:00 P.M. Director Gombac advised that residents and businesses which are within the construction area received invitations to the Open House. Administrator Vana added that the meeting has been publicized on Direct Connect.

8. **MAYOR'S REPORT**

A. CONSIDERATION OF A MOTION TO APPROVE A RESOLUTION RECOGNIZING JOHN F. POTERASKE, JR. AS THE 2014 CITIZEN OF THE YEAR IN THE CITY OF DARIEN

Mayor Weaver read the resolution into the record.

It was moved by Alderman Seifert and seconded by Alderman Kenny to approve the resolution as presented.

RESOLUTION NO. R-48-14

A RESOLUTION RECOGNIZING JOHN F. POTERASKE, JR. AS THE 2014 CITIZEN OF THE YEAR IN THE CITY OF DARIEN

Roll Call: Ayes: Beilke, Belczak, Kenny, Marchese, McIvor, Schauer, Seifert, Weaver, Ragona, Coren, Murphey, Vana

Nays: None

Absent: None

Results: Ayes 12, Nays 0, Absent 0

MOTION DULY CARRIED

John Poteraske thanked those in attendance. He noted that throughout the years there were many people who helped and gave him support. He extended special gratitude to his wife, Sharon, for her constant assistance. He thanked the residents for allowing him to serve; he thanked the City Council and Citizen of the Year Committee for the honor.

Mayor Weaver presented John F. Poteraske with the Citizen of the Year Resolution. There was resounding applause and a standing ovation from the City Council and the audience.

Mayor Weaver invited all to stay for the cake and coffee reception following the City Council Meeting. She thanked the Citizen of the Year Committee Members, Chairman Bonnie Kucera, Barbara Boyer, Carey Gonczy, Carol Mallers, and Linda Zeman.

9. **CITY CLERK'S REPORT**

There was no report.

10. **CITY ADMINISTRATOR'S REPORT**

There was no report.

11. **DEPARTMENT HEAD INFORMATION/QUESTIONS**

There was no report.

12. **TREASURER'S REPORT**

A. WARRANT NUMBER 13-14-19

It was moved by Alderman Seifert and seconded by Alderman Schauer to approve payment of Warrant Number 13-14-19 in the amount of \$575,677.91 from the enumerated funds; and \$256,120.01 from payroll funds for the period ending 02/06/14; for a total to be approved of \$831,797.92.

Alderman Kenny inquired about a payment to IRMA in the amount of \$3,446.55 for fuel tank insurance and monthly deductible. Assistant Administrator Coren responded that the premium is for separate insurance for environmental clean up in the event of underground storage tank leaks.

Alderman Seifert requested and received confirmation that NFR letters for the dry cleaner and Amoco properties have been recorded.

Roll Call: Ayes: Beilke, Belczak, Kenny, Marchese, McIvor,
Schauer, Seifert
Nays: None
Absent: None

Results: Ayes 7, Nays 0, Absent 0
MOTION DULY CARRIED

B. TREASURER'S REPORT – JANUARY 2014

Treasurer Coren reviewed year-to-date sources of revenue, expenditures, and fund balances through the month of January 2014:

<u>General Fund:</u>	Revenue \$10,667,216; Expenditures \$8,523,737; Current Balance \$3,067,065
<u>Water Fund:</u>	Revenue \$3,987,684; Expenditures \$4,181,077; Current Balance \$679,102
<u>Motor Fuel Tax Fund:</u>	Revenue \$518,632; Expenditures \$456,661; Current Balance \$354,681
<u>Water Depreciation Fund:</u>	Revenue \$62,680; Expenditures \$130,170; Current Balance \$675,229
<u>Capital Improvement Fund:</u>	Revenue \$4,139,613; Expenditures \$2,946,053; Current Balance \$5,004,657
<u>Capital Projects Debt Service Fund:</u>	Revenue \$504,297; Expenditures \$498,775; Current Balance of \$13,382

Alderman Kenny questioned the costs relative to the water main breaks. Director Gombac advised that water leak surveys are conducted regularly, and water usage is closely monitored.

13. **STANDING COMMITTEE REPORTS**

Administrative/Finance Committee – Chairman Schauer announced an Administrative/Finance Committee of the Whole Budget Meeting is scheduled for February 19, 2014, and subsequent Tuesdays until completed, at 6:30 P.M. in the Council Chambers. He advised the next regular meeting of the Administrative/Finance Committee is scheduled for March 3, 2014 at 6:00 P.M. in the upstairs conference room.

Municipal Services Committee — Chairman Marchese announced the next meeting of the Municipal Services Committee is scheduled for February 24, 2014 at 6:30 P.M.

Police Committee – Chairman McIvor announced the next meeting of the Police Committee is scheduled for March 17, 2014 at 6:00 P.M. in the Police Department Training Room.

14. **QUESTIONS AND COMMENTS – AGENDA RELATED**

Alderman McIvor stated that the Police Committee reviewed and supports New Business Item A.

Alderman Beilke would like to gain a better understanding of control of seizure money at the budget meeting.

15. **OLD BUSINESS**

There was none.

16. **CONSENT AGENDA**

Mayor Weaver reviewed the items on the Consent Agenda for the benefit of the viewing audience.

It was moved by Alderman McIvor and seconded by Alderman Seifert to approve by Omnibus Vote the following items on the Consent Agenda:

A. A MOTION GRANTING A WAIVER OF THE \$50.00 A DAY FEE FOR THE CLASS "J" TEMPORARY LIQUOR LICENSE FOR OUR LADY OF PEACE HOME & SCHOOL

B. RESOLUTION NO. R-49-14 A RESOLUTION AUTHORIZING THE MAYOR, CITY CLERK AND TREASURER TO SIGN A MODIFICATION AND EXTENSION AGREEMENT TO KEEP OPEN A LINE OF CREDIT WITH REPUBLIC BANK

C. A MOTION TO APPROVE THE RELEASE OF EXECUTIVE MINUTES THAT NO LONGER REQUIRE CONFIDENTIALITY

D. A MOTION TO GRANT A WAIVER OF THE RAFFLE LICENSE BOND REQUIREMENT FOR THE DARIEN LIONS CLUB

Roll Call: Ayes: Beilke, Belczak, Kenny, Marchese, McIvor, Schauer, Seifert

Nays: None

Absent: None

Results: Ayes 7, Nays 0, Absent 0

MOTION DULY CARRIED

17. **NEW BUSINESS**

A. CONSIDERATION OF A MOTION TO APPROVE A RESOLUTION AUTHORIZING THE CITY ADMINISTRATOR TO PURCHASE CRIME MAPPING SOFTWARE FROM PUBLIC ENGINES IN AN AMOUNT OF \$5,518.20

It was moved by Alderman McIvor and seconded by Alderman Belczak to approve the resolution as presented.

RESOLUTION NO. R-50-14

A RESOLUTION AUTHORIZING THE CITY ADMINISTRATOR TO PURCHASE CRIME MAPPING SOFTWARE FROM PUBLIC ENGINES IN AN AMOUNT OF \$5,518.20

Roll Call: Ayes: Beilke, Belczak, Kenny, Marchese, McIvor, Schauer, Seifert

Nays: None

Absent: None

Results: Ayes 7, Nays 0, Absent 0

MOTION DULY CARRIED

18. QUESTIONS, COMMENTS AND ANNOUNCEMENTS – GENERAL

Alderman Belczak announced the Lions Club will be sponsoring a blood drive at Lace School on February 25, 2014 from 4:00 to 8:00 P.M.

Alderman Beilke...

...questioned if the lease with the Darien Historical Society had been located. Mayor Weaver responded in the affirmative, and noted it is a ten-year lease which renews automatically if no action is taken. Administrator Vana added that there are two separate leases; one between the City and District 61 and another between the City and the Darien Historical Society. Mayor Weaver requested copies be given to the City Council for review during the budget process.

...invited all to attend the Citizen of the Year Dinner/Dance at Alpine Banquets in honor of John Poteraske on March 8, 2014 at 6:00 p.m.; tickets are \$30 per person, and can be purchased at City Hall.

19. ADJOURNMENT

There being no further business to come before the City Council, it was moved by Alderman McIvor and seconded by Alderman Beilke to adjourn the City Council meeting.

VIA VOICE VOTE – MOTION DULY CARRIED

The City Council meeting adjourned at 8:07 P.M.

Mayor

City Clerk

All supporting documentation and report originals of these minutes are on file in the Office of the City Clerk under File Number 02-18-14. Minutes of 02-18-14 CCM.

DRAFT

CITY OF DARIEN

MEMO

TO: City Council

FROM: Mayor Kathleen Moesle Weaver

DATE: February 27, 2014

SUBJECT: REAPPOINTMENT TO THE PLANNING AND ZONING COMMISSION

This is written to request your advice and consent to the reappointment of **Donald Hickok and Susan Vonder Heide**, to the Planning and Zoning Commission. They have expressed an interest in continuing to serve the City in this capacity.

Again, should you have any questions, please do not hesitate to contact me.

mg

CITY OF DARIEN

MEMO

TO: City Council

FROM: Mayor Kathleen Moesle Weaver

DATE: February 27, 2014

**SUBJECT: APPOINTMENT TO THE BOARD OF FIRE AND POLICE
COMMISSIONERS**

I am recommending, for your consent, the appointment of [David Kesler](#) to the Board of Fire and Police Commissioners .

He has expressed an interest in serving the City in this capacity.

If you have any questions, please do not hesitate to contact me.

mg

CITY OF DARIEN

APPLICATION FOR SERVICE ON CITY COMMISSION

City Clerk's Office
City of Darien

Are you interested in serving on a City Commission? If so, please fill in this application and return it to the Darien City Hall, 1702 Plainfield Road, Darien, Illinois 60561.

FEB 24 2014

Date February 23, 2014

Name David Kesler

Address 7321 Richmond Ave. (Phone) 630-541-3918

How long have you lived in Darien? 6 years

Where did you live prior to coming to Darien? Brookfield, IL

If Married, Spouse's Name Elizabeth Children (include ages) _____

Education: BS, MS, MBA If you attended college, what was your major? Bus. Admin.

Present Employer Retired: Teaching part time - North Central College (Phone) 630-541-3918

Address 30 N. Brainard St., Naperville, IL 60540

(Fax) _____

Nature of Occupation Teaching Economics to Graduate and Undergraduate students

Other Employment Experience 12 years as administrator at UIC College of Medicine, 10 years as public school teacher, 1 year at Government Finance Officers Association

Interests and Hobbies? _____

Of what local organizations have you been a member? (Please include offices held, if any) _____

Darien Police Chief Search Committee

Have you served the community in any other way? _____

DuPage County Election Judge

Time you would have available to serve the City Most evenings with seasonal conflicts

In which of the following areas would you like to serve? (Please feel free to check more than one.)

- | | |
|--|--|
| <input type="checkbox"/> Cable Communications Commission | <input type="checkbox"/> Citizen of the Year Committee |
| <input type="checkbox"/> Environmental Committee | <input checked="" type="checkbox"/> Fire and Police Commission |
| <input type="checkbox"/> Planning and Zoning Commission | <input type="checkbox"/> Police Pension Board |
| <input type="checkbox"/> Other (Please specify) _____ | |

What are your qualifications for this position(s)?

Serving on the Police Chief Search Committee has provided a small insight into the Fire and Police Commission.

Generally, my career experience has been in time sensitive environments where tasks needed to be performed in a structure of strict deadlines.

Why are you interested in this position(s)?

I see an opportunity to serve my community by serving on the Fire and Police Commission.

What can you contribute to this board(s) or commissions(s)?

I bring with me a timely, detail oriented completion of objective measures. I bring a background in both business and government.

CITY OF DARIEN

MEMO

TO: City Council

FROM: Mayor Kathleen Moesle Weaver

DATE: February 27, 2014

SUBJECT: REAPPOINTMENT TO BOARD OF FIRE AND POLICE COMMISSIONERS

This is written to request your advice and consent to the reappointment of Frank Noverini to the Board of Fire and Police Commissioners. He has expressed an interest in continuing to serve the City in this capacity.

Again, should you have any questions, please do not hesitate to contact me.

mg

CITY OF DARIEN

**EXPENDITURE APPROVAL LIST
FOR CITY COUNCIL MEETING ON
March 3, 2014**

Approval is hereby given to have the City Treasurer of Darien, Illinois pay to the officers, employees, independent contractors, vendors, and other providers of goods and services in the indicated amounts as set forth.

A summary indicating the source of funds used to pay the above is as follows:

General Fund		\$28,643.00
Water Fund		\$36,993.71
Motor Fuel Tax Fund		\$25,657.04
Water Depreciation Fund		
Debt Service Fund		
Capital Improvement Fund		
Special Service Area Tax Fund		
Drug Seizures Fund		\$5,518.20
	Subtotal:	\$ 96,811.95
General Fund Payroll	02/20/14	\$ 225,907.98
Water Fund Payroll	02/20/14	\$ 28,545.98
	Subtotal:	\$ 254,453.96
Total to be Approved by City Council:		\$ 351,265.91

Approvals:

Kathleen Moesle Weaver, Mayor

JoAnne E. Ragona, City Clerk

Michael J. Coren, Treasurer

Bryon D. Vana, City Administrator

CITY OF DARIEN
Expenditure Journal
General Fund
Administration
From 2/19/2014 Through 3/3/2014

<u>Vendor Name</u>	<u>Invoice Description</u>	<u>Acct Title</u>	<u>Dept Amount</u>	<u>Acct Code</u>
CALL ONE, INC.	TELEPHONE & DATA LINES - ACCT 1010-6702-0000	Telephone	4,103.17	4267
COM ED	TORNADO SIREN	ESDA	0.50	4279
COMCAST CABLE	INTERNET AT 1041 S. FRONTAGE - ACCT 8771 20 109 0343850	Consulting/Professional	94.85	4325
MUNICIPAL WEB SERVICES	JANUARY 2014 WEBSITE HOSTING	Consulting/Professional	387.00	4325
NEXTEL COMMUNICATIONS	PUBLIC WORKS AIRCARDS	Telephone	150.49	4267
OCCUPATIONAL HEALTH CENTERS	PRE-EMPLOYMENT DRUG SCREEN	Liability Insurance	50.00	4219
OFFICE DEPOT	SUPPLIES	Supplies - Office	32.37	4253
OFFICE DEPOT	SUPPLIES	Supplies - Office	29.78	4253
OFFICE DEPOT	SUPPLIES	Supplies - Office	60.79	4253
OFFICEMAX CONTRACT INC.	SUPPLIES	Supplies - Office	52.74	4253
WAREHOUSE DIRECT	SUPPLIES	Supplies - Office	234.51	4253
		Total Administration	5,196.20	

CITY OF DARIEN
Expenditure Journal
General Fund
Community Development
From 2/19/2014 Through 3/3/2014

<u>Vendor Name</u>	<u>Invoice Description</u>	<u>Acct Title</u>	<u>Dept Amount</u>	<u>Acct Code</u>
ELEVATOR INSPECTION SERVICE CO	FEBRUARY 2014 ELEVATOR INSPECTIONS	Const/Prof Reimbursable	1,568.00	4328
		Total Community Development	1,568.00	

CITY OF DARIEN
Expenditure Journal
General Fund
Public Works, Streets
From 2/19/2014 Through 3/3/2014

Vendor Name	Invoice Description	Acct Title	Dept Amount	Acct Code
ADVANTAGE CHEVROLET	REPAIR PARTS #107	Maintenance - Vehicles	21.45	4229
ADVANTAGE CHEVROLET	REPAIR PARTS #107	Maintenance - Vehicles	52.12	4229
ADVANTAGE CHEVROLET	REPAIR PARTS #107	Maintenance - Vehicles	359.43	4229
AIR-RITE HEATING & COOLING	POLICE DEPARTMENT BOILER CHECK	Maintenance - Building	383.00	4223
AIR-RITE HEATING & COOLING	POLICE DEPARTMENT BOILER REPAIR	Maintenance - Building	1,285.20	4223
ALL-STAR MAINTENANCE	POLICE & CITY HALL SIDEWALK CLEARING	Maintenance - Building	1,070.00	4223
CARQUEST AUTO PARTS STORES	REPAIR PARTS FOR FLEET VEHICLES	Maintenance - Vehicles	213.61	4229
CATCHING FLUID POWER, INC.	HYDRAULIC FITTING FOR TRUCK 108	Maintenance - Vehicles	19.26	4229
COM ED	STREET LIGHTS - ACCT 0267129091	Street Light Oper & Maint.	1,575.16	4359
COM ED	STREET LIGHTS - ACCT 0448008035	Street Light Oper & Maint.	446.83	4359
CONSTELLATION NEW ENERGY, INC.	STREET LIGHTS - ACCT 0448008035	Street Light Oper & Maint.	1,575.03	4359
CULLIGAN	BOTTLED WATER & FILTER RENTAL	Maintenance - Building	59.23	4223
DECKER SUPPLY CO.	SIGN SIZE CORRECTED	Supplies - Other	40.25	4257
FLEETPRIDE	REPAIR PARTS FOR TRUCK #106	Maintenance - Vehicles	416.58	4229
FREEWAY FORD-STERLING TRUCK	HEAD LIGHT KNOBS	Maintenance - Vehicles	15.68	4229
GENE'S TIRE SERVICE, INC.	FLAT TIRE REPAIR	Maintenance - Vehicles	42.50	4229
GRAINGER	NUTS & BOLTS & LAMP RECYCLING KIT	Maintenance - Building	88.84	4223
GRAINGER	DRUM PUMP FOR WINDSHIELD SOLVENT	Maintenance - Vehicles	95.36	4229
JOLIET SUSPENSION	REPAIR PARTS #108	Maintenance - Vehicles	1,037.15	4229
JOLIET SUSPENSION	REPAIR PARTS #108	Maintenance - Vehicles	1,037.15	4229
JSN CONTRATORS SUPPLY	GLOVES & PAINT	Liability Insurance	195.00	4219

CITY OF DARIEN
Expenditure Journal
General Fund
Public Works, Streets
From 2/19/2014 Through 3/3/2014

Vendor Name	Invoice Description	Acct Title	Dept Amount	Acct Code
NICOR GAS	1401 S. FRONTAGE ROAD - ACCT 90-84-11-1000 1	Utilities (Elec,Gas,Wtr,Sewer)	1,389.34	4271
RIC MAR INDUSTRIES, INC.	BRITE	Maintenance - Building	37.28	4223
RUSH TRUCK CENTER - CHICAGO	POWER STEERING & ABS REPAIR ON TRUCK 110	Maintenance - Vehicles	770.58	4229
UNIQUE PRODUCTS & SERVICE CORP	JANITORIAL SUPPLIES FOR P.D.	Maintenance - Building	82.85	4223
WESTOWN AUTO SUPPLY COMPANY	REPAIR PARTS FOR FLEET VEHICLES	Maintenance - Vehicles	181.74	4229
WESTOWN AUTO SUPPLY COMPANY	REPAIR PARTS FOR FLEET VEHICLES	Maintenance - Vehicles	136.62	4229
WESTOWN AUTO SUPPLY COMPANY	REPAIR PARTS FOR FLEET VEHICLES	Maintenance - Vehicles	95.00	4229
WESTOWN AUTO SUPPLY COMPANY	REPAIR PARTS FOR FLEET VEHICLES	Maintenance - Vehicles	39.72	4229
		Total Public Works, Streets	12,761.96	

CITY OF DARIEN
Expenditure Journal
General Fund
Police Department
From 2/19/2014 Through 3/3/2014

Vendor Name	Invoice Description	Acct Title	Dept Amount	Acct Code
ANDY FRAIN SERVICES	112 REGULAR HOURS - CROSSING GUARDS	Salaries	1,681.12	4010
ANDY FRAIN SERVICES	15 REGULAR HOURS - SUPERVISOR	Salaries	225.15	4010
ANDY FRAIN SERVICES	DEC-13 CREDIT FOR INSUFFICIENT CG SERVICES	Salaries	(168.68)	4010
ANTON HRUBY	UNIFORM ALLOWANCE	Uniforms	182.29	4269
BROWNELLS, INC.	RANGE SUPPLIES	Investigation and Equipment	36.46	4217
CARQUEST AUTO PARTS STORES	REPAIR PARTS FOR FLEET VEHICLES	Maintenance - Vehicles	21.12	4229
COLLEGE OF DU PAGE	JENNIFER DOLLINS - BASIC LAW ENFORCEMENT TRAINING	Training and Education	3,047.00	4263
DUPAGE CNTY CHIEFS POLICE ASSN	CAROL KOPTA-ADMINISTRATI... PROFESSIONAL DAY LUNCH	Travel/Meetings	25.00	4265
DUPAGE CNTY CHIEFS POLICE ASSN	CHIEF BROWN-ADMINISTRAT... PROFESSIONAL DAY LUNCH	Travel/Meetings	25.00	4265
DUPAGE CNTY CHIEFS POLICE ASSN	DEPUTY CHIEF COOPER-ADMINISTRA... PROFESSIONAL DAY LUNCH	Travel/Meetings	25.00	4265
ILLINOIS ATTORNEY GENERAL	FUND 0958-ATTY GEN SEX OFFENDER AWARENESS/TRAININ...	Investigation and Equipment	30.00	4217
ILLINOIS ATTORNEY GENERAL	FUND 0958-ATTY GEN SEX OFFENDER AWARENESS/TRAININ...	Investigation and Equipment	90.00	4217
JASON NORTON	UNIFORM ALLOWANCE	Uniforms	112.59	4269

CITY OF DARIEN
Expenditure Journal
General Fund
Police Department
From 2/19/2014 Through 3/3/2014

Vendor Name	Invoice Description	Acct Title	Dept Amount	Acct Code
NORTHEAST MULTIREGIONAL TRNG	FTO REFRESHER - MICHAEL LOREK	Training and Education	100.00	4263
NORTHEAST MULTIREGIONAL TRNG	FTO REFRESHER - ANTON HURBY	Training and Education	100.00	4263
NORTHEAST MULTIREGIONAL TRNG	FTO REFRESHER - JAMES MURPHY	Training and Education	100.00	4263
OTTO ENGINEERING	UNIFORM ALLOWANCE - DEYOUNG	Uniforms	75.58	4269
PUBLIC SAFETY DIRECT	UNIT 2 CAMERA - UNIT 11 RADIO	Maintenance - Vehicles	190.00	4229
RAY O'HERRON CO. INC.	UNIFORM ALLOWANCE - DOLLINS #308	Uniforms	633.67	4269
RAY O'HERRON CO. INC.	UNIFORM ALLOWANCE - JENNIFER DOLLINS	Uniforms	57.99	4269
RAY O'HERRON CO. INC.	UNIFORM ALLOWANCE - DEYOUNG	Uniforms	229.95	4269
RAY O'HERRON CO. INC.	UNIFORM ALLOWANCE - SKWERES	Uniforms	79.93	4269
THEODORE POLYGRAPH SERVICE	POLYGRAPH - JOSEPH PASTICK	Boards and Commissions	135.00	4205
TREASURER, STATE OF ILLINOIS	FUND 0958 IL ATTORNEY GENERAL SEX OFFENDER AWARENESS	Investigation and Equipment	(30.00)	4217
TREASURER, STATE OF ILLINOIS	FUND 0958 - IL ATTY GEN SEX OFFENDER AWARENESS	Investigation and Equipment	(90.00)	4217
WILLOWBROOK FORD, INC.	REPAIR PARTS - PD FLEET VEHICLES	Maintenance - Vehicles	36.74	4229
WILLOWBROOK FORD, INC.	REPAIR PARTS - PD FLEET VEHICLES	Maintenance - Vehicles	72.66	4229
WILLOWBROOK FORD, INC.	REPAIR PARTS - PD FLEET VEHICLES	Maintenance - Vehicles	711.67	4229
WILLOWBROOK FORD, INC.	RETURN ON INVOICE 5089069	Maintenance - Vehicles	(50.00)	4229

CITY OF DARIEN
Expenditure Journal
General Fund
Police Department
From 2/19/2014 Through 3/3/2014

<u>Vendor Name</u>	<u>Invoice Description</u>	<u>Acct Title</u>	<u>Dept Amount</u>	<u>Acct Code</u>
WILLOWBROOK FORD, INC.	RETURN ON INVOICE 5089032	Maintenance - Vehicles	(72.66)	4229
		Total Police Department	7,612.58	

CITY OF DARIEN
Expenditure Journal
General Fund
Business District
From 2/19/2014 Through 3/3/2014

<u>Vendor Name</u>	<u>Invoice Description</u>	<u>Acct Title</u>	<u>Dept Amount</u>	<u>Acct Code</u>
ALL-STAR MAINTENANCE	HERITAGE CENTER PLOWING & SALTING	Maintenance - Grounds	1,000.00	4227
COM ED	7515 S. CASS, UNIT D - ACCT 7156797060	Utilities (Elec, Gas, Wtr, Sewer)	266.01	4271
COM ED	7515 S. CASS, UNIT 19 (AKA UNIT F)	Utilities (Elec, Gas, Wtr, Sewer)	23.98	4271
COM ED	7515 S. CASS, UNIT BD - ACCT 7156796018	Utilities (Elec, Gas, Wtr, Sewer)	31.27	4271
FIRE & SECURITY SYSTEMS, INC.	FIRE ALARM MONITORING & INSPECTIONS - HERITAGE CENTER	Maintenance - Grounds	183.00	4227
Total Business District			1,504.26	
Total General Fund			28,643.00	

**CITY OF DARIEN
Expenditure Journal
Water Fund
Public Works, Water
From 2/19/2014 Through 3/3/2014**

Vendor Name	Invoice Description	Acct Title	Dept Amount	Acct Code
AIR-RITE HEATING & COOLING	PLANT #5 HEATER CHECK & THERMO COUPLE REPLACEMENT	Maintenance - Building	386.79	4223
AIR-RITE HEATING & COOLING	FIX HEATER GARAGE AT PLANT 2	Maintenance - Building	344.60	4223
CALL ONE, INC.	TELEPHONE & DATA LINES - ACCT 1010-6702-0000	Telephone	724.09	4267
CARQUEST AUTO PARTS STORES	REPAIR PARTS FOR FLEET VEHICLES	Maintenance - Equipment	121.86	4225
CULLIGAN	BOTTLED WATER & FILTER RENTAL	Maintenance - Building	59.24	4223
DUPAGE COUNTY PUBLIC WORKS	METER READS FROM 11/1/13 THRU 12/31/13 & JAN-14 BILLING	Data Processing	24,981.00	4336
EJ USA, INC.	EMERGENCY FIRE HYDRANT REPLACEMENT ON RICHMOND	Maintenance - Water System	2,040.00	4231
FREEWAY FORD-STERLING TRUCK GRAINGER	HEAD LIGHT KNOBS NUTS & BOLTS & LAMP RECYCLING KIT	Maintenance - Equipment Maintenance - Building	15.68 14.59	4225 4223
HD SUPPLY WATERWORKS	REPAIR CLAMPS	Maintenance - Water System	418.52	4231
HD SUPPLY WATERWORKS	REPAIR CLAMP	Maintenance - Water System	254.00	4231
HD SUPPLY WATERWORKS	REPAIR CLAMPS	Maintenance - Water System	459.57	4231
HD SUPPLY WATERWORKS	REPAIR CLAMPS	Maintenance - Water System	261.73	4231
HD SUPPLY WATERWORKS	REPAIR CLAMPS	Maintenance - Water System	456.85	4231
JSN CONTRATORS SUPPLY	GLOVES & PAINT	Liability Insurance	195.00	4219
JSN CONTRATORS SUPPLY	GLOVES & PAINT	Maintenance - Water System	60.00	4231
LAWSON PRODUCTS INCORPORATED	BOLTS & NUTS FOR VALVE/HYDRANT REPAIRS	Maintenance - Water System	450.44	4231
LAWSON PRODUCTS INCORPORATED	STAINLESS STEEL NUT & BOLTS FOR VALVE & HYDRANT REPAIRS	Maintenance - Water System	849.14	4231

CITY OF DARIEN
Expenditure Journal
Water Fund
Public Works, Water
From 2/19/2014 Through 3/3/2014

Vendor Name	Invoice Description	Acct Title	Dept Amount	Acct Code
NICOR GAS	1401 S. FRONTAGE ROAD - ACCT 90-84-11-1000 1	Utilities (Elec, Gas, Wtr, Sewer)	1,389.33	4271
NICOR GAS	1930 MANNING RD, D.G. - ACCT 05-00-21-1000 R	Utilities (Elec, Gas, Wtr, Sewer)	433.22	4271
NICOR GAS	8600 LEMONT - ACCT 23-64-41-1000 1	Utilities (Elec, Gas, Wtr, Sewer)	399.47	4271
NICOR GAS	1897 MANNING DR - ACCT 12-34-41-1000 7	Utilities (Elec, Gas, Wtr, Sewer)	136.94	4271
PATTEN INDUSTRIES, INC.	BOLTS - WATER TRACTOR #406	Maintenance - Equipment	195.42	4225
PATTEN INDUSTRIES, INC.	REPAIR PARTS FOR TRACTOR #406	Maintenance - Equipment	86.80	4225
PATTEN INDUSTRIES, INC.	HYDRAULIC HOSES & SEALS FOR TRACTOR #406	Maintenance - Equipment	167.69	4225
RIC MAR INDUSTRIES, INC.	BRITE	Maintenance - Building	37.27	4223
SUBURBAN LABORATORIES	WATER SAMPLES SOC & COLIFORM	Quality Control	2,054.47	4241
			36,993.71	
			36,993.71	

CITY OF DARIEN
Expenditure Journal
Motor Fuel Tax
MFT Expenses
From 2/19/2014 Through 3/3/2014

<u>Vendor Name</u>	<u>Invoice Description</u>	<u>Acct Title</u>	<u>Dept Amount</u>	<u>Acct Code</u>
DUPAGE MATERIALS COMPANY	COLD PATCH	Road Material	810.00	4245
ELMHURST CHICAGO STONE COMPANY	CA-7 STONE DELIVERED TO PUBLIC WORKS	Road Material	1,335.77	4245
NORTH AMERICAN SALT CO.	ROAD SALT	Salt	6,572.55	4249
NORTH AMERICAN SALT CO.	ROAD SALT	Salt	3,057.50	4249
NORTH AMERICAN SALT CO.	ROAD SALT	Salt	<u>13,881.22</u>	4249
		Total MFT Expenses	25,657.04	
		Total Motor Fuel Tax	<u>25,657.04</u>	

CITY OF DARIEN
Expenditure Journal
Drug Seizures Fund
Drug Forfeiture Expenditures
From 2/19/2014 Through 3/3/2014

Vendor Name	Invoice Description	Acct Title	Dept Amount	Acct Code
PUBLIC ENGINES	COMMAND CENTRAL ANALYTICS - INITIAL SUBSCRIPTION	Dues and Subscriptions	5,518.20	4213
		Total Drug Forfeiture Expenditures	5,518.20	
		Total Drug Seizures Fund	5,518.20	
Report Total			96,811.95	

**AGENDA MEMO
CITY COUNCIL
March 3, 2014**

ISSUE STATEMENT

Approval of an ordinance authorizing the disposal of surplus property.

ORDINANCE

BACKGROUND/HISTORY

Staff is requesting that the following property be declared as surplus property and auctioned using an on-line auction service, Public Surplus, or disposed of:

	ITEM	EXPLANATION
1	HP Laser Jet P3005DN Printer w/power cable.	Broke, no longer useful to City
2	Galls Wireless Receiver and Transmitter RH92. Frequency 171.105. Two transmitter, 3 receivers and parts. 3 Wireless transmitter holders by G & G.	No longer useful to City
3	Sony Microcassette Recorder M-629V	No longer useful to City
4	1 Glock Uncle Mike's Side Kick Holster Size 25	No longer useful to City
5	(2) PR24 Holders	No longer useful to City
6	TASER X26 Holster	No longer useful to City
7	Porta clip radio holder for HT Motorola	No longer useful to City
8	Leather Police Jacket size 42L.	No longer useful to City
9	8GB Apple Ipod S/n CCQHRSYFDNQW	From Property Room
10	(3) Misc. earrings, appear broken	From Property Room
11	White Ipod s/n CCQGMY3PDNQW	From Property Room
12	Black folding knife "POLICE"	From Property Room
13	Siler color "SISTERS" ring	From Property Room

STAFF/COMMITTEE RECOMMENDATION

At their February 18, 2014, meeting, the Police Committee unanimously approved of the listed items above to be declared surplus property and be auctioned using Public Surplus or be disposed of.

ALTERNATE CONSIDERATION

Not approving this ordinance at this time would be an alternate consideration.

DECISION MODE

This item will be placed on the March 3, 2014, City Council Agenda for formal approval.

CITY OF DARIEN

DU PAGE COUNTY, ILLINOIS

ORDINANCE NO. _____

**AN ORDINANCE AUTHORIZING THE SALE
OF PERSONAL PROPERTY
OWNED BY THE CITY OF DARIEN**

ADOPTED BY THE

MAYOR AND CITY COUNCIL

OF THE

CITY OF DARIEN

THIS 3rd DAY OF MARCH, 2014

**Published in pamphlet form by authority of the
Mayor and City Council of the City of Darien,
DuPage County, Illinois, this _____ day of
March, 2014.**

**AN ORDINANCE AUTHORIZING THE SALE
OF PERSONAL PROPERTY
OWNED BY THE CITY OF DARIEN**

WHEREAS, in the opinion of at least three fourths of the corporate authorities of the City of Darien, it is no longer necessary or useful, or for the best interests of the City of Darien, to retain ownership of the personal property hereinafter described; and

WHEREAS, it has been determined by the Mayor and City Council of the City of Darien to sell said personal property at a Public Auction or dispose of said property.

NOW, THEREFORE, BE IT ORDAINED BY THE CITY COUNCIL OF THE CITY OF DARIEN, DU PAGE COUNTY, ILLINOIS, IN THE EXERCISE OF ITS HOME RULE POWERS, as follows:

SECTION 1: The Mayor and City Council of the City of Darien find that the following described personal property, now owned by the City of Darien, is no longer necessary or useful to the City of Darien and the best interests of the City of Darien will be served by auctioning it using Public Surplus or disposing of said property.

	ITEM	EXPLANATION
1	HP Laser Jet P3005DN Printer w/power cable.	Broke, no longer useful to City
2	Galls Wireless Receiver and Transmitter RH92. Frequency 171.105. Two transmitter, 3 receivers and parts. 3 Wireless transmitter holders by G & G.	No longer useful to City
3	Sony Microcassette Recorder M-629V	No longer useful to City
4	1 Glock Uncle Mike's Side Kick Holster Size 25	No longer useful to City
5	(2) PR24 Holders	No longer useful to City
6	TASER X26 Holster	No longer useful to City
7	Porta clip radio holder for HT Motorola	No longer useful to City
8	Leather Police Jacket size 42L.	No longer useful to City
9	8GB Apple Ipod S/n CCQHRSYFDNQW	From Property Room
10	(3) Misc. earrings, appear broken	From Property Room
11	White Ipod s/n CCQGMY3PDNQW	From Property Room
12	Black folding knife "POLICE"	From Property Room
13	Siler color "SISTERS" ring	From Property Room

SECTION 2: The City Administrator is hereby authorized and directed to sell the

aforementioned personal property, now owned by the City of Darien. Items will be auctioned using Public Surplus or disposing of said property.

SECTION 3: This Ordinance and each of its terms shall be the effective legislative act of a home rule municipality without regard to whether such Ordinance should (a) contain terms contrary to the provisions of current or subsequent non-preemptive state law, or (b) legislate in a manner or regarding a matter not delegated to municipalities by state law. It is the intent of the corporate authorities of the City of Darien that to the extent that the terms of this Ordinance should be inconsistent with any non-preemptive state law, that this Ordinance shall supersede state law in that regard within its jurisdiction.

SECTION 4: This Ordinance shall be in full force and effect from and after its passage and approval as provided by law.

PASSED BY THE CITY COUNCIL OF THE CITY OF DARIEN, DU PAGE COUNTY,

ILLINOIS, this 3rd day of March, 2014

AYES: _____

NAYS: _____

ABSENT: _____

APPROVED BY THE MAYOR OF THE CITY OF DARIEN, DU PAGE COUNTY,

ILLINOIS, this 3rd day of March, 2014.

KATHLEEN MOESLE WEAVER, MAYOR

ATTEST:

JOANNE E. RAGONA, CITY CLERK

APPROVED AS TO FORM:

CITY ATTORNEY

AGENDA MEMO
CITY COUNCIL
MEETING DATE: March 3, 2014

Issue Statement

Zoning Map: Approval of the updated City of Darien Official Zoning Map for 2014.

RESOLUTION

Discussion/Overview

The Municipal Services Committee considered this matter at their meeting on February 24, 2014. The Committee recommends approval of the updated Darien Zoning Map.

The discussion summary follows as “Additional Information”.

Ordinance attached.

Decision Mode

The Municipal Services Committee considered this item at its meeting on February 24, 2014. The City Council will consider this item at its meeting on March 3, 2014.

Additional Information

Issue Statement

Zoning Map: Approval of the updated City of Darien Official Zoning Map for 2014.

Discussion

Illinois State Statute requires that each municipality publish a current Zoning Map by March 31st of each year. The Zoning Map must reflect all annexations and zoning changes approved during the previous calendar year.

The updated map includes all of the annexations and zoning activity that occurred in 2013, including ordinance references related to special use, variation, PUD amendments and annexations: special use: approval for a medical clinic at 8190 Cass Avenue, cell tower at the Darien Municipal Services Facility at 1041 S. Frontage Road, special use approvals for drinking and eating establishments for Dotty’s at 7516 Cass Avenue and Stella’s at 2415 75th Street and special use approval for a drinking establishment for the Darien VFW at 7515 Cass Avenue.

A street name correction was also made, changing “Sawmill Creek Drive” to “Sawmill Drive”, the street name noted on the plat of subdivision.

Recommendation

Staff recommends the Municipal Services Committee make a motion recommending approval of the updated Zoning Map.

Municipal Services Committee Review – February 24, 2014

The Municipal Services Committee considered this matter at their meeting on February 24, 2014. The following members were present: Alderman Joseph Marchese – Chairman, Alderman Tina Beilke, Alderman Joerg Seifert, Dan Gombac – Director and Elizabeth Lahey – Secretary.

Dan Gombac, Director, reviewed the agenda memo.

The Committee did not have any questions or concerns.

Without further discussion, Alderman Seifert made a motion to recommend approval as presented, seconded by Alderman Beilke.

Upon a voice vote, THE MOTION CARRIED by a vote of 3-0.

**A RESOLUTION APPROVING AND PUBLISHING THE UPDATED
CITY OF DARIEN OFFICIAL ZONING MAP**

WHEREAS, pursuant to the Illinois Municipal Code, 65 ILCS 5/11-13-19, a municipality is required to publish a zoning map no later than March 31st of each year; and

WHEREAS, the zoning map attached hereto as "[Exhibit A](#)" and made a part thereof, is a current zoning map showing zoning uses, divisions, restrictions, regulations, and classifications within the City; and

WHEREAS, the Corporate Authorities find the zoning map, attached hereto as **Exhibit "A,"** correctly reflects zoning actions approved by the Corporate Authorities within the last calendar year.

NOW, THEREFORE, BE IT RESOLVED BY THE CITY COUNCIL OF THE CITY OF DARIEN, DUPAGE COUNTY, as follows:

SECTION 1: That the City hereby approves the zoning map, attached as "**Exhibit A**".

SECTION 2: This Resolution shall be in full force and effect from and after its passage and approval as provided by law.

PASSED BY THE CITY COUNCIL OF THE CITY OF DARIEN, DUPAGE COUNTY,
ILLINOIS, this 3rd day of March, 2014.

AYES: _____

NAYS: _____

ABSENT: _____

APPROVED BY THE MAYOR OF THE CITY OF DARIEN, DUPAGE COUNTY,
ILLINOIS, this 3rd day of March, 2014.

KATHLEEN MOESLE WEAVER, MAYOR

ATTEST:

JOANNE E. RAGONA, CITY CLERK

APPROVED AS TO FORM:

CITY ATTORNEY

AGENDA MEMO
CITY COUNCIL
MEETING DATE: March 3, 2014

Issue Statement

Minor PUD Amendment for the Darien Towne Centre PUD: Amvets Collection Center, Walmart, 2189 75th Street: Annual review, approval.

ORDINANCE

Discussion/Overview

The Municipal Services Committee considered this matter at their meeting on February 24, 2014. The Committee recommends approval as presented.

The draft ordinance is attached.

Decision Mode

The Municipal Services Committee considered this matter at their meeting on February 24, 2014. The City Council will consider this matter at their meeting on March 3, 2014.

Additional Information

Issue Statement

Minor PUD Amendment for the Darien Towne Centre PUD: Amvets Collection Center, Walmart, 2189 75th Street: Annual review, approval.

Discussion

The City Council granted a minor amendment to the Darien Towne Centre PUD, [**Ordinance No. O-04-05**](#), March 7, 2005, to allow an Illinois Amvets Collection Center in the Walmart parking lot. A copy of the ordinance is attached.

The approval was for 1 year. Since then, the City has granted 1-year extensions. The current approval expires on March 7, 2014.

Over the year, staff has not observed any problems with the collection center. Amvets is seeking approval to continue operating the donation center.

The approvals thus far have been in 1 year increments.

Staff Findings/Recommendations

Staff recommends that the Municipal Services Committee make the following motion recommending approval of the extension of the approval originally granted in 2005:

Based on the submitted petition, the proposed amendment to the Darien Towne Centre PUD meets the standards of the Darien Zoning Ordinance and, therefore, I move that the Municipal Services Committee recommend to the City Council approval of the request associated with this petition, subject to:

- 1. Approval extended for a period of 1 year.**

Municipal Services Committee Review – February 24, 2014

The Municipal Services Committee considered this matter at their meeting on February 24, 2014. The following members were present: Alderman Joseph Marchese – Chairman, Alderman Tina Beilke, Alderman Joerg Seifert, Dan Gombac – Director and Elizabeth Lahey – Secretary.

Dan Gombac, Director, reviewed the agenda memo.

The Committee did not have any questions or concerns.

Without further discussion, Alderman Seifert made a motion to recommend approval as presented, seconded by Alderman Beilke.

Upon a voice vote, THE MOTION CARRIED by a vote of 3-0.

**CITY OF DARIEN
DU PAGE COUNTY, ILLINOIS**

ORDINANCE NO. _____

**AN ORDINANCE GRANTING A ONE (1) YEAR EXTENSION
TO THE PREVIOUSLY APPROVED MINOR AMENDMENT
TO AN APPROVED PLANNED UNIT DEVELOPMENT**

**(Darien Towne Centre PUD, 2189 75th Street, Illinois,
Amvets Collection Center at Walmart)**

**ADOPTED BY THE
MAYOR AND CITY COUNCIL
OF THE
CITY OF DARIEN**

THIS DAY 3rd OF MARCH, 2014

**Published in pamphlet form by authority of the
Mayor and City Council of the City of Darien,
DuPage County, Illinois, this ____ day of March,
2014.**

**AN ORDINANCE GRANTING A ONE (1) YEAR EXTENSION
TO THE PREVIOUSLY APPROVED MINOR AMENDMENT
TO AN APPROVED PLANNED UNIT DEVELOPMENT**

(Darien Towne Centre PUD, 2189 75th Street, Illinois,

Amvets Collection Center at Walmart)

WHEREAS, the City of Darien is a home rule unit of local government pursuant to the provisions of Article VII, Section 6, of the Illinois Constitution of 1970; and

WHEREAS, as a home rule unit of local government, the City may exercise any power and perform any function pertaining to its government except as limited by Article VII, Section 6; and

WHEREAS, heretofore, pursuant to Ordinance No. O-18-93, the City granted a special use for a Planned Unit Development (PUD) for certain property described therein and commonly referred to as the “Darien Towne Centre”; and

WHEREAS, heretofore, pursuant to **Ordinance No. O-4-05**, the City granted a minor amendment to the Darien Towne Centre PUD for an Illinois Amvets Collection Center in the Wal-Mart parking lot, for an initial period of one (1) year, which was to be reviewed by the City Council on an annual basis as to the location and to address any operational issues; and

WHEREAS, heretofore, pursuant to Ordinance No. O-4-05, the City granted one (1) year extensions on February 6, 2006, April 2, 2007, March 3, 2008, March 2, 2009, February 1, 2010, February 7, 2011, March 5, 2012, and March 4, 2013; and

WHEREAS, staff has reviewed the collection center location and has not found any operational issues; and

WHEREAS, on February 24, 2014, the Municipal Services Committee of the City Council reviewed the petition and forwarded its recommendation of approval of this petition to the City Council; and

WHEREAS, the City Council has reviewed the findings and recommendations described above and now determines to grant a one (1) year extension subject to the terms, conditions and limitations described below.

NOW, THEREFORE, BE IT ORDAINED BY THE CITY COUNCIL OF THE CITY OF DARIEN, DU PAGE COUNTY, ILLINOIS, IN THE EXERCISE OF ITS HOME RULE POWERS, as follows:

SECTION 1: Extension of the Previously Approved Minor Amendment to PUD Granted.

The previously granted minor amendment to the approved PUD for the Darien Towne Centre by

Ordinance No. O-4-05 is hereby extended for a one (1) year period, at which time the City Council shall review the location and address any operational issues.

SECTION 2: Home Rule. This ordinance and each of its terms shall be the effective legislative act of a home rule municipality without regard to whether such ordinance should (a) contain terms contrary to the provisions of current or subsequent non-preemptive state law, or (b) legislate in a manner or regarding a matter not delegated to municipalities by state law. It is the intent of the corporate authorities of the City of Darien that to the extent of the terms of this ordinance should be inconsistent with any non-preemptive state law, that this ordinance shall supercede state law in that regard within its jurisdiction.

SECTION 3: Effective Date. This Ordinance shall be in full force and effect from and after its passage and approval as provided by law.

PASSED BY THE CITY COUNCIL OF THE CITY OF DARIEN, DU PAGE COUNTY, ILLINOIS, this 3rd day of March, 2014.

AYES: _____

NAYS: _____

ABSENT: _____

APPROVED BY THE MAYOR OF THE CITY OF DARIEN, DU PAGE COUNTY, ILLINOIS, this 3rd day of March, 2014.

KATHLEEN MOESLE WEAVER, MAYOR

ATTEST:

JOANNE E. RAGONA, CITY CLERK

APPROVED AS TO FORM:

CITY ATTORNEY

CITY OF DARIEN
DU PAGE COUNTY, ILLINOIS

ORDINANCE NO. 0-04-05

**AN ORDINANCE GRANTING A MINOR AMENDMENT
TO AN APPROVED PLANNED UNIT DEVELOPMENT**

(Darien Towne Centre PUD, 2189 75th Street, Illinois Amvets collection center at Wal-Mart)

**ADOPTED BY THE
MAYOR AND CITY COUNCIL
OF THE
CITY OF DARIEN**

THIS 7th DAY OF MARCH, 2005

Published in pamphlet form by authority
of the Mayor and City Council of the City
of Darien, DuPage County, Illinois, this
9th day of March, 2005.

ORDINANCE NO. 0-04-05

**AN ORDINANCE GRANTING A MINOR AMENDMENT
TO AN APPROVED PLANNED UNIT DEVELOPMENT**

(Darien Towne Centre PUD, 2189 75th Street, Illinois Amvets collection center at Wal-Mart)

WHEREAS, the City of Darien is a home rule unit of local government pursuant to the provisions of Article VII, Section 6 of the Illinois Constitution of 1970; and

WHEREAS, as a home rule unit of local government, the City may exercise any power and perform any function pertaining to its government except as limited by Article VII, Section 6;

WHEREAS, heretofore, pursuant to Ordinance O-18-93, the City granted a special use for a Planned Unit Development (PUD) for certain property described therein and commonly referred to as "Darien Towne Centre";

WHEREAS, the City of Darien received a new application to modify the approved PUD to allow an Illinois Amvets collection center within the parking lot of Wal-Mart; and

WHEREAS, on January 24, 2005, the Planning and Development Committee of the City Council reviewed the petition and has forwarded its recommendations to the City Council; and

WHEREAS, the City Council has reviewed the findings and recommendations described above and now determines to grant the petition subject to the terms, conditions and limitations described below.

NOW, THEREFORE, BE IT ORDAINED BY THE CITY COUNCIL OF THE CITY OF DARIEN, DU PAGE COUNTY, ILLINOIS, IN THE EXERCISE OF ITS HOME RULE POWERS, as follows:

ORDINANCE NO. 0-04-05

SECTION 1: Approval of Minor Amendment to PUD Granted. A minor amendment to the approved PUD for Darien Town Centre is hereby approved to allow an Illinois Amvets collection center within the parking lot of Wal-Mart, 2189 75th Street, in the area shown on Exhibit "A".

SECTION 2: Remainder of PUD. All of the terms, conditions and limitations of Ordinance O-18-93 remain in full force and effect.

SECTION 3: Home Rule. This ordinance and each of its terms shall be the effective legislative act of a home rule municipality without regard to whether such ordinance should (a) contain terms contrary to the provisions of current or subsequent non-preemptive state law, or (b) legislate in a manner or regarding a matter not delegated to municipalities by state law. It is the intent of the corporate authorities of the City of Darien that to the extent of the terms of this ordinance should be inconsistent with any non-preemptive state law, that this ordinance shall supercede state law in that regard within its jurisdiction.

SECTION 4: Effective Date; Limitation. This Ordinance shall be in full force and effect from and after its passage and approval as provided by law. The approval granted by this Ordinance shall remain in effect for an initial period of one (1) year, at which time the Council shall review the location with Amvets and address any operational issues.

**PASSED AND APPROVED BY THE CITY COUNCIL OF THE CITY OF DARIEN,
DU PAGE COUNTY, ILLINOIS, this 7th day of March, 2005.**

AYES: 6 - Cotten, Hagen, Marchese, Poteraske, Tikalsky, Weaver

NAYS: 0 - NONE

ABSENT: 1 - Biehl

ORDINANCE NO. 0-04-05

APPROVED BY THE MAYOR OF THE CITY OF DARIEN, DU PAGE COUNTY,

ILLINOIS, this 7th day of March, 2005.

ATTEST:



CARMEN D. SOLDATO, MAYOR

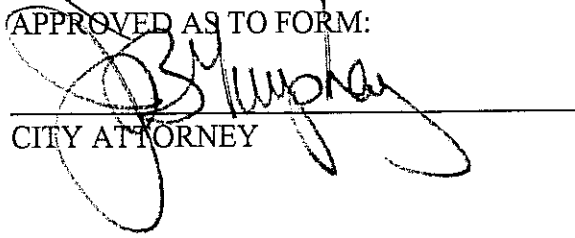

JOANNE F. COLEMAN, CITY CLERK

APPROVED AS TO FORM:

CITY ATTORNEY



5,000 SF
OUTDOOR FENCED STORAGE
PERMITTED PER ZONE USE (NO
SALES PERMITTED)

TRUCK DISPLAY AREA
MAINTAINED FOR
TRUCK DISPLAY ONLY
NO OTHER USES

STOCKPILE ROAD

75th Street

Lynman Ave.

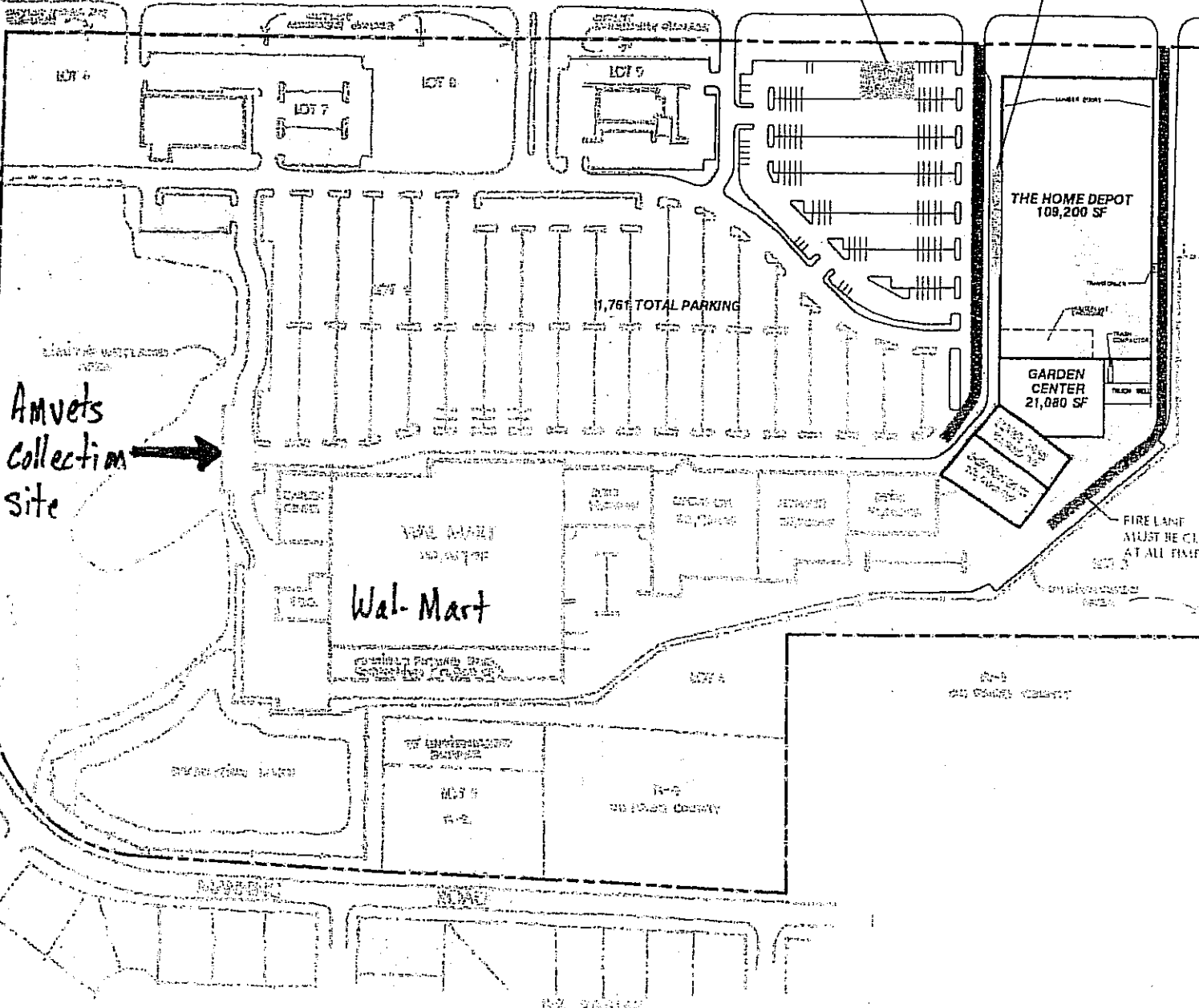

Amvets
collection
site →

Wal-Mart

THE HOME DEPOT
109,200 SF

GARDEN
CENTER
21,080 SF

1,761 TOTAL PARKING

FIRE LANT
MUST BE CLEAR
AT ALL TIME

AGENDA MEMO

**City Council
March 3, 2014**

ISSUE STATEMENT

A resolution accepting the unit price proposal for analytical soil testing fees from Testing Services Corporation at the proposed unit prices for certain waste for a period of May 1, 2014 through April 30, 2015.

RESOLUTION

BACKGROUND

During the year the department generates excavated materials from various Public Works projects, such as water main breaks, valve and hydrant replacements, landscape restorations and ditching projects. On July 30, 2011, Public Act 96-1416-Clean Construction or Demolition Debris (CCDD) became law. The law required the Illinois EPA to propose rules to establish technical requirements for CCDD facilities; set operating standards for uncontaminated soil fill operations; and develop standards for the maximum allowable concentrations of chemical constituents in uncontaminated soil generated during construction or demolition activities and used as fill material.

The law effects owners and operators of CCDD facilities and uncontaminated soil fill operations as well as governmental entities, road builders, landscapers, and other contractors and excavators that deliver CCDD or uncontaminated soil generated from construction or demolition activities to CCDD facilities and uncontaminated soil fill operations.

Staff requested competitive quotes for the required analytical testing services and received two (2) competitive quotes, see [Attachment A](#). The lowest competitive total cost quote was provided by Testing Services Corporation as they relate to the requirements of our 2014-15 City Council awarded landfill, Elmhurst Chicago Stone and E. F. Heil. The pricing is to be held in place from May 1, 2014 to April 30, 2015.

The expenditure would come from the Water, Street and Capital accounts, depending on the specific project generating the waste. The total estimated costs for all maintenance and budgetary programs for this item are \$26,000.00 pending Capital Project budget approval.

COMMITTEE RECOMMENDATION

The Municipal Services Committee recommends approval of this resolution with Testing Services Corporation.

ALTERNATE CONSIDERATION

As directed by the Municipal Services Committee.

DECISION MODE

This item will be placed on the March 3, 2014 City Council agenda for formal approval.

RESOLUTION NO. _____

A RESOLUTION ACCEPTING THE UNIT PRICE PROPOSAL FOR ANALYTICAL SOIL TESTING FROM TESTING SERVICES CORPORATION AT THE PROPOSED UNIT PRICES FOR CERTAIN WASTE FOR A PERIOD OF MAY 1, 2014 THROUGH APRIL 30, 2015

BE IT RESOLVED BY THE CITY COUNCIL OF THE CITY OF DARIEN, DU PAGE COUNTY, ILLINOIS, as follows:

SECTION 1: The City Council of the City of Darien does hereby accept a proposal from Testing Services Corporation for analytical soil testing per the unit price proposal for a period of May 1, 2014 through April 30, 2015, attached hereto as "**Exhibit A**".

SECTION 2: This Resolution shall be in full force and effect from and after its passage and approval as provided by law.

PASSED BY THE CITY COUNCIL OF THE CITY OF DARIEN, DU PAGE COUNTY, ILLINOIS, this 3rd day of March, 2014.

AYES: _____

NAYS: _____

ABSENT: _____

APPROVED BY THE MAYOR OF THE CITY OF DARIEN, DU PAGE COUNTY, ILLINOIS, this 3rd day of March, 2014.

KATHLEEN MOESLE WEAVER, MAYOR

ATTEST:

JOANNE E. RAGONA, CITY CLERK

APPROVED AS TO FORM:

CITY ATTORNEY

David Fell

From: David Hurst [dhurst@tscorp.com]
Sent: Tuesday, February 04, 2014 12:27 PM
To: David Fell
Subject: RE: testing
Attachments: David L Hurst.vcf; 20140204122438277.pdf

Dave,

2014 rates attached.

Regards,

David L. Hurst
Environmental Department Manager
dhurst@tscorp.com
Direct: 630-784-4005
Mobile: 630-738-0102



www.tscorp.com

Testing Service Corporation
360 S. Main Place
Carol Stream, IL 60188

From: David Fell [mailto:dfell@darienil.gov]
Sent: Monday, February 03, 2014 11:34 AM
To: 'David Hurst'
Cc: Dan Salvato
Subject: testing

Hi Dave

Here is the testing quote spreadsheet we discussed.

David J Fell
Darien Municipal Services

Phone: 630-429-1711
Fax: 630-887-0091
E-mail: dfell@Darienil.gov

CONFIDENTIALITY NOTE:

This email message is for the sole use of the intended recipient(s) and may contain confidential and privileged information. Any unauthorized review, use, disclosure or distribution of any kind is strictly prohibited. If you are not the intended recipient, please contact the sender via reply e-mail and destroy all copies of the original message.

2/4/2014



TESTING SERVICE CORPORATION

Corporate Office:

360 S. Main Place, Carol Stream, IL 60186-2404
630.462.2600 • Fax 630.653.2988

TSC - PN 48,245 - 2014 UPDATE Basic CCDD Soil Disposal Pricing

4-Feb-14

City of Darien is seeking quotes to provide testing services for construction material spoils generated from repair, maintenance, and installation of municipal utilities.

	UNIT COST	
Coordinate with a landfill facility and complete a project or address environmental site review for analytical testing and landfill location recommendation report for City construction material disposal	EACH <u>100</u>	
Stockpile or site sample collection, including travel to site and transport sample to laboratory. 4 hour Maximum per visit	HOUR <u>110</u>	
Use of PID Instrument for Screening Soils	EACH <u>50</u>	
Compare testing results to IEPA tier one remediation objectives in tabular format, if objectives meet clean fill results provide a licensed professional engineer stamped LPC-663 with a summary report describing sampling procedures followed and results of analytical testing.	EACH <u>400</u>	
If results are found to be contaminated recommend and coordinate with appropriate landfill dump facility to obtain non-special or special waste permit for disposal.	EACH <u>200*</u>	
RESIDENTIAL ANALYTICAL TEST		
For average 2500 feet ditch project		
VOCs	EACH <u>162</u>	
SVOCs	EACH <u>270</u>	
PNAs	EACH <u>135</u>	
RCRA 8 Total metals	EACH <u>113</u>	
RCRA 8 TCLP Metals	EACH <u>203</u>	0 * *
PH	EACH <u>24</u>	2,247.00 +
Preserved Vials for volatile testing	EACH <u>12</u>	1,505.00 +
		<u>3,752.00</u> **
RESIDENTIAL ANALYTICAL TEST		
For average 2500 feet ditch project		
Pesticides/PCBs	EACH <u>162</u>	
Herbicides	EACH <u>262</u>	
BTEXs	EACH <u>54</u>	
EPA 351AC1100 Full Panel	EACH <u>1505</u>	

2,247.00

\$2247.00
+ \$1505.00
\$3752.00

VIALS BY PROJECT

2014 [Signature]
TSC

TOTAL
Note analytical costs for 7 to 10 business day turn around.

Typical site time is 3 to 4 hours.

* Does not include additional analytical testing.

** Analysis selected dependent on soil location and disposal facility. Additional testing may be required and testing requirements are subject to change

David Fell

From: David Hurst [dhurst@tscorp.com]
Sent: Tuesday, February 04, 2014 12:27 PM
To: David Fell
Subject: RE: testing
Attachments: David L Hurst.vcf; 20140204122438277.pdf

Dave,

2014 rates attached.

Regards,

David L. Hurst
Environmental Department Manager
dhurst@tscorp.com
Direct: 630-784-4005
Mobile: 630-738-0102



www.tscorp.com

Testing Service Corporation
360 S. Main Place
Carol Stream, IL 60188

From: David Fell [mailto:dfell@darienil.gov]
Sent: Monday, February 03, 2014 11:34 AM
To: 'David Hurst'
Cc: Dan Salvato
Subject: testing

Hi Dave

Here is the testing quote spreadsheet we discussed.

David J Fell
Darien Municipal Services

Phone: 630-429-1711
Fax: 630-887-0091
E-mail: dfell@Darienil.gov

CONFIDENTIALITY NOTE:

This email message is for the sole use of the intended recipient(s) and may contain confidential and privileged information. Any unauthorized review, use, disclosure or distribution of any kind is strictly prohibited. If you are not the intended recipient, please contact the sender via reply e-mail and destroy all copies of the original message.



TESTING SERVICE CORPORATION

Corporate Office:

360 S. Main Place, Carol Stream, IL 60188-2404
630.462.2600 • Fax 630.653.2988

TSC - PN 48,245 - 2014 UPDATE Basic CCDD Soil Disposal Pricing
4-Feb-14

City of Darien is seeking quotes to provide testing services for construction material spoils generated from repair, maintenance and installation of municipal utilities.

	UNIT COST	
Coordinate with a landfill facility and complete a project or address environmental site review for analytical testing and landfill location recommendation report for City construction material disposal	EACH	<u>100</u>
Stockpile or site sample collection, including travel to site and transport sample to laboratory. 4 hour Maximum per visit	HOUR	<u>110</u>
Use of PID Instrument for Screening Soils	EACH	<u>50</u>
Compare testing results to IEPA tier one remediation objectives in tabular format, if objectives meet clean fill results provide a licensed professional engineer stamped LPC-663 with a summary report describing sampling procedures followed and results of analytical testing.	EACH	<u>400</u>
If results are found to be contaminated recommend and coordinate with appropriate landfill dump facility to obtain non-special or special waste permit for disposal.	EACH	<u>200*</u>
RESIDENTIAL ANALYTICAL TEST		
For average 2500 feet ditch project		
VOCs	EACH	<u>162</u>
SVOCs	EACH	<u>270</u>
PNAs	EACH	<u>135</u>
RCRA 8 Total metals	EACH	<u>113</u>
RCRA 8 TCLP Metals	EACH	<u>203</u>
PH	EACH	<u>24</u>
Preserved Vials for volatile testing	EACH	<u>12</u>
		2,247.00 +
		1,505.00 +
		3,752.00 *+
		0. *
RESIDENTIAL ANALYTICAL TEST		
For average 2500 feet ditch project		
Pesticides/PCBs	EACH	<u>162</u>
Herbicides	EACH	<u>292</u>
BTEXs	EACH	<u>54</u>
EPA 351AC1100 Full Panel	EACH	<u>1605</u>

2,247.00

\$2247.00
+ \$1505.00
\$3752.00

VITARS 134 Project

2014 [Signature]
TSC

TOTAL
Note analytical costs for 7 to 10 business day turn around.

Typical site time is 3 to 4 hours.

* Does not include additional analytical testing.

** Analysis selected dependent on soil location and disposal facility. Additional testing may be required and testing requirements are subject to change

David Fell

From: Erin Curley [ecurley@geoconcompanies.com]
Sent: Monday, February 03, 2014 2:15 PM
To: David Fell
Cc: Dan Salvato
Subject: RE: Testing Quote
Attachments: GEOCON 2014 TESTING QUOTE FOR DARIEN.pdf; MAC List for COC.pdf
David,

Attached is our pricing for CCDD services.

Thank you for contacting us.

Erin Curley
GEOCON
815-806-9986

From: David Fell [mailto:dfell@darienil.gov]
Sent: Monday, February 03, 2014 11:32 AM
To: Erin Curley
Cc: Dan Salvato
Subject: Testing Quote

Good Morning Erin,

I am seeking a quote for analytical testing services based on the attached form. We have been using Heil landfill and understand that some project sites may be more complicated then others and will address as the need arises.

David J Fell
Darien Municipal Services

Phone: 630-429-1711
Fax: 630-887-0091
E-mail: dfell@Darienil.gov

GEOCON

2014 City of Darien is seeking quotes to provide testing services for potentially impacted locations of construction material spoils generated from repair, maintenance, and installation of municipal utilities.

		UNIT COST	
Coordinate with a landfill facility and complete a project or address environmental site review for analytical testing and landfill location recommendation report for City construction material disposal	EACH	<u>\$120.00</u>	(1 HR X \$120.00/HOUR)
Stockpile or site sample collection, including travel to site and transport sample to laboratory. 4 hour Maximum per visit	HOUR	<u>\$120.00</u>	(PER HOUR)
Use of PID Instrument for Screening Soils	EACH	<u>\$100.00</u>	(PER DAY)
Compare testing results to IEPA tier one remediation objectives in tabular format, if objectives meet clean fill results provide a licensed professional engineer stamped LPC-883 with a summary report describing sampling procedures followed and results of analytical testing.	EACH	<u>\$315.00</u>	(2 HRS X \$120/HR, 0.5 HR P.E. X \$150/HR)
If results are found to be contaminated recommend and coordinate with appropriate landfill dump facility to obtain non-special or special waste permit for disposal.	EACH	<u>\$240.00</u>	* Does not include additional analytical testing. (2 HOURS)
ANALYTICAL TEST			
VOCs	EACH	<u>\$180.00</u>	**
SVOCs	EACH	<u>\$300.00</u>	**
PNAs	EACH	<u>\$150.00</u>	**
RCRA 8 Total metals	EACH	<u>\$128.00</u>	**
RCRA 8 TCLP Metals	EACH	<u>\$226.00</u>	**
PH	EACH	<u>\$12.00</u>	**
Preserved Vials for volatile testing	EACH	<u>\$20.00</u>	**
Cyanide	EACH	<u>\$36.00</u>	**
Pesticides/PCBs	EACH	<u>\$180.00</u>	**
Herbicides	EACH	<u>\$280.00</u>	**
BTEXs	EACH	<u>\$60.00</u>	**
	TOTAL	<u>2465</u>	<div style="border: 1px solid black; border-radius: 50%; width: 150px; height: 80px; display: flex; align-items: center; justify-content: center; margin: 10px auto;"> 2,465.00 </div>

ANALYTICAL TEST FULL PANEL

EPA 351AC1100		EACH	<u>\$2,032.00</u>	** SEE ATTACHED FULL MAC LIST
---------------	--	------	-------------------	-------------------------------

Note analytical costs for 7 to 10 day turn around.

PRICE 1: \$2,079.00 when PE determines testing (VOCs, SVOCs, Pesticides/PCBs, RCRA 8 Total Metals, RCRA 8 TCLP Metals, ph) (Based on one soil sample tested.)

PRICE 2: \$3,067.00 when CCDD facility requires the full MAC List of chemicals (see attached MAC List) (Based on one soil sample tested.)

TOTAL ~~6962~~
SEE BELOW

** Analysis selected dependent on soil location and disposal facility. Additional testing may be required and testing requirements are subject to change

\$2465.00
+ \$2032.00

\$ 4,497.00

N/A
N/A

AGENDA MEMO

City Council

March 3, 2014

Issue Statement

A resolution accepting a proposal from Associated Technical Services (ATS) for the 2013-14 Water Leak Survey, in the amount of \$8,288.28 for the Leak Detection Phase and a per unit cost for the Leak Location Phase in the amount of \$350.00 per mainline or service leak, and \$95.00 per fire hydrant leak or mainline valve for a total amount not to exceed \$14,500.

RESOLUTION

Background/History

The FY 13/14 Budget includes \$14,500.00 for this year's Water Leak Survey Program. The leak survey program as proposed by Associated Technical Services (ATS) includes two phases consisting of surveying 473,616 lineal feet (89.7 lineal miles) of water main and the second phase includes the pinpointing of leaks found in the system. The proposed quote from ATS is structured in a fashion that the vendor is additionally motivated to find as many leaks as possible since the proposal is further driven on unit costs for pinpointing leaks. Based on leak detection results from 2000, 2002, 2003, 2007, and 2010/11 ATS has located an average of 20 various leaks per year, whereas the competition has identified an average of 4.67 leaks for years 2008, 2009, and 2012.

Should the City have 25 various leaks, (see [Attachment A](#), labeled as Competitive Quote Summary), the cost for the program could be approximately an additional \$6,200 dollars for a total expense of approximately \$14,488. Staff does anticipate finding leaks, but the amount will not be known until the leak survey is completed.

Staff has recently identified that water pumpage has begun to increase since December of 2013. The water usage based on the time of year is higher by approximately 19.43% than during the past years same time periods. See [Attachment B](#), labeled as Intake Water Demand 2011-2014 Months-November through February. The increased water intake does not correlate with the amount billed.

Based on the unprecedented winter and the increased water intake there may be several water main breaks that have not surfaced due to the severe frost in the ground. Pending the leak detection phase, additional funding may be required for pinpointing leaks. In the event additional pinpointing of leaks is required, staff will forward a separate agenda memo requesting additional funding.

City staff had solicited for competitive quotes and received four. Based on the detection phase, ATS is the lowest competitive quote. Funding for the Water Leak Maintenance Program would be expended from the following line item of the FY13/14 Budget:

ACCOUNT NUMBER	ACCOUNT DESCRIPTION	FY 13/14 BUDGET	PROPOSED EXPENDITURE	PROPOSED BALANCE
02-50-4326	LEAK DETECTION	\$14,500.00	\$8,288.28- \$14,500	\$6,211.72-\$0

Committee Recommendation

The Municipal Services Committee recommends a resolution accepting a proposal from Associated Technical Services (ATS) for the 2013-14 Water Leak Survey, in the amount of \$8,288.28 for the Leak Detection Phase and a per unit cost for the Leak Location Phase in the amount of \$350.00 per mainline or service leak, and \$95.00 per fire hydrant leak or mainline valve for a total amount not to exceed \$14,500. Associated Technical Services has provided very satisfactory services to the City of Darien in the past.

Alternate Consideration

Not approving this proposal.

Decision Mode

This item will be placed on the March 3, 2014 City Council agenda for formal consideration.

RESOLUTION NO. _____

A RESOLUTION ACCEPTING A PROPOSAL FROM ASSOCIATED TECHNICAL SERVICES (ATS) IN THE AMOUNT OF \$8,288.28 FOR THE LEAK DETECTION PHASE AND A PER UNIT COST FOR THE LEAK LOCATION PHASE IN THE AMOUNT OF \$350.00 PER MAINLINE OR SERVICE LEAK, AND \$95.00 PER FIRE HYDRANT LEAK OR MAINLINE VALVE FOR A TOTAL AMOUNT NOT TO EXCEED \$14,500.00

BE IT RESOLVED BY THE CITY COUNCIL OF THE CITY OF DARIEN, DU PAGE COUNTY, ILLINOIS, as follows:

SECTION 1: The City Council of the City of Darien hereby authorizes the Mayor to accept a proposal from Associated Technical Services in the amount of \$8,288.28 for the Leak Detection Phase and a per unit cost for the Leak Location Phase in the amount of \$350.00 per mainline or service leak, and \$95.00 per fire hydrant leak or mainline valve for a total amount not to exceed \$14,500.00, a copy of which is attached hereto as "[Exhibit A](#)" and is by this reference expressly incorporated herein.

SECTION 2: This Resolution shall be in full force and effect from and after its passage and approval as provided by law.

PASSED BY THE CITY COUNCIL OF THE CITY OF DARIEN, DU PAGE COUNTY, ILLINOIS, this 3rd day of March, 2014.

AYES: _____

NAYS: _____

ABSENT: _____

APPROVED BY THE MAYOR OF THE CITY OF DARIEN, DU PAGE COUNTY, ILLINOIS, this 3rd day of March, 2014.

KATHLEEN MOESLE WEAVER, MAYOR

ATTEST:

JOANNE E. RAGONA, CITY CLERK

APPROVED AS TO FORM:

CITY ATTORNEY

ASSOCIATED TECHNICAL SERVICES LTD

www.ATSLIMITED.com



Established 1979

524 W. ST. CHARLES RD. VILLA PARK, IL

Office: 630.834.1558 / Fax: 630.834.5501

February 14, 2014

City of Darien
 Department of Municipal Services
 1702 Plainfield Road
 Darien, Illinois 60561

Attn: Dan Gombac
 Director of Municipal Services

RE: 2014 Darien Water Distribution
 System - Leak Detection Survey Proposal

Dear Mr. Gombac,

We are pleased to present the following proposal to perform another comprehensive "ATS LEAK DETECTION & LOCATION SURVEY" for the City of Darien. With an "ATS Leak Survey Program" your water conservation program remains on its best possible course.

ATS and the City of Darien: A 30 Year Partnership of Success

ATS has had a long and successful relationship with the City of Darien dating back 30 years.

- Since 1984, ATS has accurately pinpointed over 70 leaks during over 60 Scheduled and Emergency Leak Location Call-Outs
- Another 172 leaks were detected and pinpointed during system-wide leak surveys that were conducted in 1997, 2000, 2002, 2003, 2008, 2011 and 2012
- Altogether, ATS has pinpointed over 240 leaks for Darien with consistent accuracy. ATS is proud to be the firm that Darien relies upon whenever you need that leak found promptly and accurately.

ATS conducted 7 leak surveys for Darien in 1997, 2000, 2002, 2003, 2008, 2011, 2012

<u>Firm</u>	<u>Main</u>	<u>Service</u>	<u>Hydrant</u>	<u>Valve</u>	<u>Totals</u>	<u>Daily Loss (GPD)</u>	<u>Value / Yr.</u>	<u>Pay Back</u>
ATS Survey Total:	23	23	97	29	172	2,730,599 GPD	\$ 3,890,609	
ATS Survey Average:	3.3	3.3	14	4	24.5	390,085 GPD	\$ 555,801	\$ 92: \$1
Competition Averages:	0.25	0.50	7.25	1.50	9.75		Much less than ATS	

Accuracy is not just putting our mark on the leak, but accurately detecting every suspect leak and turning every suspect leak into an accurate location. It is also important to note that our pinpointing accuracy 97.8% for these seven Darien surveys for leaks being located within the first repair excavation or on the appurtenance that was determined to be leaking. Superior ATS pinpointing accuracy saves the City by limiting and reducing costs for dry holes, pavement restoration and landscaping restoration costs.

WATER CONSERVATION SPECIALISTS

EMERGENCY LEAK PINPOINTING • LEAK DETECTION SURVEYS • UNDERGROUND UTILITY LOCATION • GIS / GPS SURVEYS
 VALVE EXERCISING • CCTV PIPE INSPECTIONS • HYDRANT TESTING & FLUSHING • LOCATION EQUIPMENT SALES & TRAINING

A Comprehensive ATS Leak Survey is essentially accomplished with these steps:

- **Prepare a Proposal** – We take into consideration essential factors like system size, age, layout and pipe materials; frequency and type of annually occurring leaks and main breaks; amount of unaccounted for water loss and system pressure. Once our proposal has been submitted and approved, we will be in contact with you to schedule the **Pre-Survey Meeting**.
- **Prepare a Survey Completion Schedule** upon request using a detailed Gantt Chart. **ATS** uses **Microsoft Office Project Professional** to accomplish this task. This schedule and corresponding milestones dates would be updated as the survey progresses.
- **Pre-Survey Meeting** – conducted with **ATS Survey Project Manager**, to discuss all aspects of the project from methodology, equipment, documentation and results with the **City**.
- **The Designated Survey Area is divided up into manageable “survey sub-areas” which are scaled directly from your maps to get the quantity of water main in each area.**
- **ATS Crews will check in with the City at the start of every survey workday.** You’ll always know where we’ll be that day and what kind of progress we’re making. Our office never closes. **ATS Crews and Offices are available 24 hours a day / 365 days a year.**
- **Ultrasonic Leak Detection Phase** of each survey sub-area. We will log every monitored appurtenance, every detected suspect leak site, all map discrepancies and any inaccessible points that need to be found or exposed so they can be surveyed.
- **Develop List of Inaccessible Points** that we are unable to locate or access. Submit this list the **City** for preparation as needed so **ATS** can survey these points.
- **Map Discrepancies** - All appurtenances that are shown incorrectly or not shown at all on your maps will be logged on our survey sheets. They can also be located via GPS upon request so you can update your water atlases.
- **Computerized Electronic Leak Location Phase** – Re-survey every suspect leak site and accurately pinpoint every subsequently detected leak.
- **Leak Location Reports** are submitted daily as leaks are located. Leak locations are marked, diagramed and documented in detail, and located with GPS upon request.
- **Interim Monthly Progress Reports** - Area by area progress summary by phase, total leak types and calculated water and revenue recovery to date. They are typically submitted monthly, or by request anytime you need an update.
- **Inaccessible Appurtenances** - Monitor all previously inaccessible points so that every possible point is surveyed and pinpoint all of the subsequently detected leaks.
- **Re-Survey All Repaired Leak Sites** and pinpoint all subsequently detected Leaks.
- **Final Survey Report** - Gather Leak Repair Data, Recovery calculations, Maps displaying Leak Locations and assemble **Final Report**. Present the comprehensive **Final Survey Report** to the **City**

ATS INCENTIVE-BASED COMPREHENSIVE LEAK SURVEY PROGRAM

The **ATS Comprehensive Leak Survey Program** is the most thorough and successful leak survey program in the business on two fronts – **Superior Findings and Consistently Accurate Pinpointing**.

Incentive-Based Survey Pricing – **ATS** originated this type of pricing to compete against low price / low results lump sum bids. This is also our most popular survey program. Without guaranteed money beyond the detection phase, this unique contract pricing puts the burden on **ATS** to produce results. With this type of contract proposal, the detection phase is essentially a lump sum figure based upon the amount of water main you have, while pinpointing is a unit cost per pinpointed leak.

Incentive-Based Survey Pricing gives the City the opportunity to save money if the water system turns out to be tighter than expected. The City still wins if it ends up that your water system contains a good number of leaks because you won't spend an extra dollar without getting a money-saving and water-conserving leak in return. Since there are no fee guarantees for **ATS** beyond the detection phase, there is natural incentive for **ATS** to accurately find as many leaks as possible for the City.

ESTIMATE OF COST

SURVEY AREA: The City has ± 89.7 lineal miles (473,616 LF) of water distribution system.

Monitored System Appurtenances will include:

- Every Fire Hydrant (± 1,613)
- Every accessible Fire Hydrant Auxiliary Valve (± 1,613)
- Every accessible Main Line Valve (± 1,434 boxes and vaults)
- ± 175 strategically located Customer Service Line Curb Stops (*aka B-Boxes*)
- Approximately ± 4,835 potential points will be ultrasonically surveyed for leak sounds

ATS Incentive-Based Proposal – You only pay for as many leaks as you actually have.

Detection Phase: 473,616 per lineal feet of water main @ \$ 0.0175 per LF = \$ 8,288.28

Location Phase: \$ 350.00 for Every Pinpointed Main Line and Service Line Leak.

\$ 95.00 for Every Fire Hydrant Leak and Valve Leak.

Total Cost: We will not exceed total amount of your budgeted funds. Should we detect an extraordinary amount of leaks, we will classify and prioritize leak pinpointing so that leaks that are estimated to be the largest leaks will be pinpointed first.

SURVEY COMPLETION TIME: We estimate the **DETECTION PHASE** of the survey can be completed in approximately 20 workdays. The duration of the **LOCATION PHASE** will depend upon the number of suspect leak sites to investigate and actual number, type and location of those pinpointed leaks. The Location phase may take another 5 - 10 workdays to complete. We will have the leak survey project completed on or before your April 30, 2012 deadline.

ADDITIONAL CALLOUT SAVINGS: Discounted Leak Pinpointing - While your leak survey is underway, any leak or utility location callout that can be scheduled during normal weekday work hours will be discounted to the \$ 350.00 leak survey rate. This represents a savings of up to \$ 250.00 per callout.

SCOPE OF WORK

ATS Comprehensive Survey Program: **Every** fire hydrant, accessible hydrant auxiliary valve, and **every** mainline valve will be monitored for leak sounds. When a water system starts to get tighter, there is more emphasis on the surveyor to have to dig deeper to find the leaks that are not making obvious leak sounds. This fact makes monitoring every valve essential to finding these tough leaks. Valves are the best quality listening point possible. The thoroughness of this aggressive survey insures that every detectable leak is discovered.

Ultrasonic Leak Detection Phase: The existence and general neighborhood of every detected suspect leak is established with *FCS S-30 Ultrasonic Leak Detection Equipment*. A preliminary leak size and leak type classification is also made at that time. A significant difference between an *ATS Leak Survey* and the other surveyors is in the ultrasonic leak detection phase's number of checkpoints. You put yourself in the best position to detect more leaks by listening to as many points as possible, especially mainline valves. No one checks more points for leak sounds as accurately and as thoroughly as *ATS*.

Detection Survey Records: Every accessible fire hydrant, hydrant auxiliary valve and mainline valve is monitored for suspect leak sounds. B-Boxes are checked only in the vicinity of a detected suspect leak site. Valuable survey and system data is collected and logged on these records. ***This data includes:*** Appurtenance Type and Location, General Conditions Encountered, Accessibility, Map Discrepancies and Leak Sound Characteristics.

Computerized Leak Analysis & Pinpointing Phase: Every suspect leak site, no matter how slight the sound, is electronically confirmed with one of our 10 computerized *FCS AccuCorr, FCS Tri-Corr 2002, FCS 9090 or Sewerin SeCorr Leak Noise Correlator Systems*. A leak's exact location is pinpointed by analyzing, timing and measuring leak sound waves simultaneously from two monitoring points. The pinpointing phase begins with the re-surveying every suspect leak site, followed electronic Correlator analysis of that site to eliminate a suspect leak site or accurately confirm the presence and pinpoint a leak's exact location.

"X" Marks The Spot!: The pinpointed location of every mainline, service line and valve leak will be marked in the field with spray marking paint with an "X". The exceptions are homeowner's side service leaks and hydrant leaks. A ***"Leak Location Report"*** form documents the location and type, characteristics of every pinpointed leak.

GPS Leak Location Data: Upon request, every pinpointed leak will be documented using *Magellan and Trimble Professional GPS Receivers*. Locations will be electronically provided with industry standard sub-meter accuracy with sub-foot accuracy available if requested. The location of every pinpointed leak is also displayed in survey area maps in the ***Final Report***.

Re-Monitoring Phase: The location and immediate vicinity of every repaired survey leak will be ultrasonically resurveyed for any possible leaks whose sound may have been covered up by the sound of the initial leak. Any subsequently detected leaks will be pinpointed.

Overnight (24-Hour) and Weekend Survey: Whenever conditions dictate that this type of equipment can be useful, **ATS** can employ **FCS-Radcom's SoundSens Leak Location System**. With this system **ATS** has the capability of placing 2 to 8 correlating remote sensors in a strategic pattern where leakage is suspected. Each Sensor can be programmed to run a correlation between it and any combination of Sensors to determine if and where leaks may exist. This is useful in areas where safety is an issue, high traffic and industrial areas where ambient noise and building noise can inhibit accurate leak detection. Traditional detection survey techniques during evening and weekend hours may also be performed when necessary.

Water Main / Service Line Tracing and Valve Location: All of the water main and service connections are accurately located in the vicinity of every leak location. This helps insure that every survey leak is pinpointed as accurately as possible. All utility line location work is expertly performed with **Radiodetection RD8000, RD7000 High Performance Utility Location Systems, Schonstedt, CTS Berger and Radiodetection Ferromagnetic Metal Locators**. **No one works a leak site harder than ATS!**

Inaccessible Points & Map Discrepancies: A listing of all appurtenances that are found to be inaccessible or visually un-locatable will be submitted to the **City** so **ATS** can return to check it. Once that point has been located and/or prepared for us. We never know when we will encounter a leak that is only detectable at one listening point. This added measure to help ensure that every detectable leak is detected and pinpointed accurately.

Interim Survey Status Reports: **Survey Status Reports** are typically submitted monthly, or upon request whenever you would like an up to date status report. This report gives you all the essential information you need so you'll know the exact status of your survey with area-by-area completion percentages and water recovery. This report concisely summarizes all of our survey activities and findings, breakdowns of the number and type of leaks found in each area; plus revenue recovery calculations for each leak you've already repaired.

Leak Location Reports: This is an individual report form that details the exact location and characteristics of each pinpointed leak. These forms are submitted daily as the leaks are pinpointed. The **City** with actual leak repair information updates each **Leak Report** which is used to calculate water loss and revenue recovery data for the **Final Report**.

Final Report: Five (5) copies of a comprehensive **FINAL SURVEY REPORT** will be submitted after the completion of the survey. Additional copies are available upon request. These reports concisely detail all of our survey activities and findings; estimated & calculated leak sizes; revenue recovery calculations for each leak; area maps showing leak locations, leak location reports; general observations and recommendations. **Final Survey Reports** are also digitally available in Microsoft Word or PowerPoint 2010, or PDF formats, that can be printed, emailed or recorded on your choice of CD, DVD or USB Flash drives upon request. The **Final Report** will be submitted within 30 days of the completion of our field work and all leak repairs.

Initiating The Survey: We only need your verbal authorization followed by your **Purchase Order** and / or signed **ATS Leak Survey Contracts**, to schedule your **Pre-Survey Meeting**, and initiate your Survey. The **Pre-Survey Meeting** details all aspects of the survey, our survey procedures, types of documentation, survey duration, the kind of assistance we made request during the survey, repair information we'll need from the **City** for our **Final Report**, projected survey results, and set up a starting date for the survey.

There are more good reasons why choosing ATS makes excellent business sense.

Superior Experience - ***ATS helped introduce leak location correlators, and subsequently started to specialize in leak detection in 1979.*** As a result, ***ATS*** has performed more leak surveys and pinpointed more leaks with this technology than anyone. ***ATS*** developed the leak survey techniques, correlator survey specs and field strategies that have become the standards for the industry. Over the years some of ***FCS – Fluid Conservation Systems'*** top people including Regional Managers, Sales Staff, Instructors have received training from ***ATS***. ***FCS*** also uses ***ATS*** for testing new equipment developments and software upgrades.

Conserving Municipal Manpower and Resources - Public works departments are already stretched to their limit, providing quality services to your citizens. With our tremendous amount of municipal leak survey experience, ***ATS*** frees up your staff so that they can concentrate on their normal duties without distraction. Municipal involvement is normally answering questions, and freeing up inaccessible points \ during the location phase on an "as-needed basis".

24 Hour Customer Support During and After the Survey – ***ATS never has less than two crews on call 24 hours a day / 365 days a year. ATS has a fleet of 10 Correlator Equipped "ATS Leakmobiles" out in the field five days a week.*** Every mobile van is fully equipped with an experienced and trained two-person crew capable of handling any leak location or utility location situation you will ever have. While other water suppliers have to typically wait 3 or more hours for our competitors to arrive, ***ATS*** is almost always on the scene in 60 - 90 minutes or less of your call for help. ***No other firm consistently responds to emergencies as quickly as ATS.***

Superior Results - For 34 years, ***ATS*** has been out in the field nearly every day performing leak surveys, utility locations and leak pinpointing. Subsequently our listening skills are going to be that much more acute. Your survey is more effectively accomplished while we detect more leaks and pinpoint them with more consistent accuracy than any other survey firm.

Cost Effectiveness - Compare the actual survey results found by ***ATS*** verses the others. Call on our references. We've highlighted those municipalities that have used ***ATS*** and our competition. The differences in the survey findings are remarkable.

- ***No one listens more intently to every accessible access point as ATS.*** Therefore we detect more suspect leak sounds than anyone else.
- ***No one works a suspect leak site more aggressively than ATS.*** Therefore, we turn more suspect leak sounds into confirmed leak locations than anyone else.
- ***No one spends more time analyzing a suspect leak site as thoroughly as ATS.*** Therefore no one pinpoints more leaks as accurately as ***ATS*** does. For our clients, more precise leak pinpointing means less digging and less restoration costs.
- ***ATS spends more time performing your leak survey so you can spend less time repairing them, and get a greater return in recovering precious water and reducing your water losses.***
- ***As an ATS Survey Client, you automatically receive discounted pricing on and scheduled leak and utility line location callouts that you may need while your leak survey is underway. You will also receive preferred customer discounted pricing and priority scheduling on all scheduled and emergency callouts you may need during the remainder of your budget year.***

Pre-Survey Meeting: Your verbal authorization followed by you Purchase Order and / or signed **ATS** Leak Survey Contracts, is all we need to schedule your Leak Survey. The **Pre-Survey Meeting** details all aspects of the survey. We will discuss how the survey will be performed, how to interpret the survey documentation, format and delivery of survey data to your staff, and the type of assistance and mutual cooperation that will be required during the survey. All Field and Administrative Personnel that would be involved or has a general interest in the survey are encouraged to attend.

Scheduling the Survey: We can typically begin your leak survey shortly after receiving your authorization to proceed. It's a good idea to wait until your crews have finished any hydrant / water main flushing programs that you might have scheduled. We often find leaking hydrants or some leaks that might have been caused by water hammering or subsequent water pressure variations during the flushing process. We would also ask for a list of streets that you might have scheduled for resurfacing. We would start the detection survey on those streets first so that you minimize the chances of covering up an old leak with a brand new street surface. Many cities use **ATS** to survey their water main, before and after a construction project, just to make sure no leaks were caused by earth moving or other heavy construction equipment during construction activities.

We welcome the opportunity to meet with you and your staff to answer any questions you may have about **ATS Survey Equipment and Methodology**. Please take a little time to read through the enclosed literature, and feel free to contact anyone on the reference list that we've enclosed. We hope that as you review our proposal package that you will gain some new knowledge of our professional services and unique skills that give us the necessary expertise to perform a thorough and successful leak survey. Thank you for your consideration of **Associated Technical Services Ltd.**

Yours Truly,
ASSOCIATED TECHNICAL SERVICES LTD.

Ralph L. Gross
Executive Vice President

BASIC SCHEDULE OF PRICES

LEAK DETECTION & LOCATION SURVEYS

(Survey Area to be defined by Owner)

1. Minimum Leak Survey - 10,000 Lineal Feet of Water Main = \$ _____

1a. Survey Areas over 10,000 Lineal Feet of pipe will be priced as follows:

<u>More than</u>	<u>But less than</u>	<u>Unit Price Per Lineal Foot</u>
10,000 LF	19,999 LF	\$ _____
20,000 LF	39,999 LF	\$ _____
40,000 LF	59,999 LF	\$ _____
60,000 LF	79,999 LF	\$ _____
80,000 LF	99,999 LF	\$ _____
100,000 LF	or More	<u>\$ 0.0175</u>

1b) **LOCATION:**

\$ 350.00 for every Main Line or Service Line Leak.

\$ 95.00 for every Fire Hydrant Leak and Valve Packing Leak.

Extras: \$ 350.00* discounted flat rate for Leak Pinpointing Callouts

\$ 295.00* Homeowner's side service leak pinpointing scheduled by City

** Callouts scheduled during normal weekday work hours for the duration of the survey contract. Homeowner service leaks must be scheduled by the City with the Homeowner.*

2. **MOBILIZATION & MILEAGE:** - MILEAGE IS WAIVED

\$ 1.75 per mile - round trip from ATS Office to the Project Site.

TERMS: Payment is due upon receipt of invoice. **ATS** will, at its option, submit periodic billings based upon the percentage of completion of the project. **ATS** also reserves the right to determine the percentage of completion for billing purposes. Interest rates will be based at 2% per month upon the unpaid balance at 30 days from the date of the invoice and thereafter.

PLEASE NOTE: All prices are based upon utmost cooperation and advance preparation by the **Owner**. Such as accurate plans and knowledge of the water system, and making all needed appurtenances accessible to our survey crews. See Section II of the attached **"General Conditions for Leak Surveys"** for a detailed listing of responsibilities of **ATS** and the **Owner**. **ATS** reserves the right to adjust the **"Basic Schedule of Prices"** if preliminary field investigation of the survey reveals extraordinary, hazardous or otherwise adverse conditions.

Please be sure to forward any questions you have directly to Ralph L. Gross at 630.834.1558 (ofc)

GENERAL CONDITIONS

LEAK DETECTION & LOCATION SURVEYS

Responsibility of ATS / Associated Technical Services Ltd.

- A) **Two-Person crew qualified to operate the *ATS Leak Detection & Location System*.**
- B) **The “*ATS Leak Detection & Location System*” consists of:**
- ***FCS S30 and FCS S20 Ultrasonic Leak Surveyor Instruments (Leak Detection Phase)***
 - ***FCS/Fluid Conservation Systems and Sewerin Leak Noise Correlators (Leak Location Phase)***
 - ***FCS and Sewerin Ultrasonic Preamplifiers (Leak Location Phase)***
 - ***FCS, Wilcoxon, Vibrometer, Sewerin Accelerometers, Gas Sensors, Hydrophone Sensors***
 - ***Radcom FCS SoundSens Programmable Leak Correlation / Localization System***
 - ***Radiodetection RD7000 and RD8000 Utility Location Systems; CST Berger, Schonstedt and Radiodetection Ferro Magnetic Location Equipment for buried valve enclosures.***
- C) **“*ATS Leakmobile*” - Mobile Van with self-contained power supply and /or capability of operating from an alternate VAC 60 Hz source, or suitable alternate vehicle at the discretion of *ATS*.**
- D) ***Mobilization / Mileage* – Round Trip, Portal-to-Portal and On-Site.**
- E) ***On-Site Consultation with Owner* or their representatives as necessary.**
- F) **The entire area designated by the *Owner* shall be surveyed for leakage.** Detected leaks shall be pinpointed only on that part of the water system maintained by the *Owner*. Unless it is previously specified and ordered, customer service line leaks will only be pinpointed up to the municipal side of the curb stop without additional charges. Leaks on the customer side of the curb stop typically require a separate appointment so *ATS* can make contact with the service line inside the building.
- G) **Only those leaks that are detected by the *ATS Leak Survey* are to be included in the pinpointing phase of this contract.** Unless other previous arrangements are made, any pinpointing of any incidentally or coincidentally occurring leakage, main breaks or previously known leakage that was not initially included in our proposal or as a part of this agreement shall be charged at our normal rates for scheduled / emergency service call-outs.
- H) **If the “*Re-monitoring of Repaired Leak Sites*” service is specified, included in our proposal and ordered, this agreement, leak repairs to that site must be completed within 30 days after that leak’s location report was submitted to the *Owner*.** The *Owner* then must notify *ATS* at the time of repairs so re-monitoring can be scheduled. All subsequently detected leakage will be located.
- I) ***ATS* will establish and mark the location of a leak or leaks in the field with either marking paint, a field stake and / or written individual “*ATS Leak Location Report*”.**
- J) ***ATS* will provide basic traffic warning equipment and traffic control and re-direction with flagmen on an as-needed basis, whenever conditions dictate the necessity of these safety precautions.** ***ATS Work Zone Safety Equipment* includes but is not limited to safety vests, vehicle arrow boards, strobe warning lights and safety cones that are used whenever our vehicles are parked during the course of the leak survey on residential and other light or slower traffic areas.**

GENERAL CONDITIONS FOR LEAK SURVEYS

RESPONSIBILITY OF OWNER

The **Owner** will insure easy access to all main line valves, valve boxes or other strategically necessary access points. This may also include exposing and cleaning out auxiliary valves and b-boxes on an as-needed basis if they will facilitate the accurate confirmation and pinpointing of a detected leak. ***This could include:*** breaking loose needed valve covers; pumping water out all valve vaults and boxes and, if necessary, removing debris from those enclosures to make the valves and adjoining pipelines accessible. The **Owner** will also make access available to any point or location strategically needed by **ATS** to perform said work at the discretion of **ATS**.

- If the **Owner** orders leak pinpointing between the curb stop and the customer's building, the **Owner** shall be responsible for making contact with the customer. Pinpointing can be performed on a weekday from 7:00 AM to 4:00 PM without incurring overtime charges.
- The **Owner** will make available to **ATS** any and all available location maps, schematics, as-built drawings, final reports from previous leak surveys, and any other data pertaining to the area being surveyed. Access to the "IDOT LMO-2" Annual Water Audit Reports is also very helpful.
- The **Owner** will make available knowledgeable, qualified personnel for consultation and assistance regarding the **Owner's** water system.
- Identify the authorized representatives of the **Owner** to act on behalf of the **Owner** and sign **ATS** agreements, purchase orders and additional work orders.
- Give **ATS** right of access, and necessary identification required, and notify appropriate authorities (Police, Fire Dept., Public Works Dept., etc.) as needed of program underway.
- The **Owner** will at its option, provide **Traffic Warning Equipment, Traffic Control and Re-Direction with Flagmen** on an ***as-needed basis***, should conditions dictate the necessity of this safety precaution. Instances such as a lane closure in a heavy traffic area may require hiring the services of a **Work Zone Safety Vendor** to provide the necessary traffic control equipment such as barricades, warning lights, arrow panels and temporary barriers. The **Owner** must approve any use of a **Work Zone Safety Vendor** in advance. **Owner** will be responsible for the costs of the **Work Zone Safety Vendor**.
- **Owner's** repair crews shall make a reasonable effort to provide **ATS** with accurate leak repair information whenever this data is available. ***Repair data should detail the following:*** Date of repair; type of leak; approximate size and shape of the leak orifice; approximate water pressure; and method of repair. This information is necessary for **ATS** to make leak size, water loss and revenue recovery calculations for a comprehensive ***"Leak Survey Final Report"***.

Please Note: **ATS** does not guarantee the detection or accurate pinpointing of a leak or leaks, but does assure that a best effort in that regard will be put forward.

Certain input data to the ***ATS Leak Detection & Location System*** is based upon information received from the **Owner**. The accuracy of the **Owner's** data will directly affect the results of the Leak Survey. **ATS** will attempt to verify such data by consultation with the **Owner** and thereupon will have a right to rely upon the accuracy of the **Owner's** data. **ATS** is not liable for any costs to the **Owner** as a result of incomplete or inaccurate data supplied by the **Owner** or their representatives.

ATS Experience, Manpower and Equipment

- In 1979, **ATS** became the first company in America to use leak noise correlators.
- **ATS** developed the correlator-based leak survey procedures and methodology that are considered to standard of the industry and subsequently taught by **FCS** and **ATS**.
- Every **ATS Field Technician** is Fully Trained and Experienced in a wide range of applications. We only use **Top of the Line – State of the Art Equipment** for All Phases of Leak Detection and Location Procedures; Field Strategies and Locating All Types of Underground Utilities.
- **ATS Crew Chiefs** average over 15 years of Correlator Based Leak Survey Experience.
- Leading correlator manufacturers, **FCS/Fluid Conservation Systems, Metravib and Palmer**, have relied on **ATS** to perform beta testing of new equipment and software developments. **ATS** has trained some of **FCS'** key staff members and provides training assistance for new personnel.
- All phases of an **ATS Leak Survey** are performed with a fully trained Two-Person Crew.
- **ATS has a fleet of Ten Complete Correlator Systems and dedicated Surveyor Vans with Crews, (ATS Leakmobiles)** that are fully equipped with correlator systems; Utility Location Equipment and every tool needed to perform leak detection and location in all types of conditions.
- No other leak survey company matches **ATS' Level of Experience, Accuracy and Results.**

Leak Survey Equipment: *ATS uses the best equipment available on the market today. Here are some of the key components that are used to equip every "ATS Leakmobile".*

Leak Detection Phase

FCS S-30 Ultrasonic Leak Surveyors
FCS S-20 Ultrasonic Leak Surveyors
PGA 710 Ultrasonic Leak Surveyors

Leak Location Phase

FCS Accu-Corr Correlators
FCS TriCorr Leak Noise Correlators
FCS C9090 Leak Noise Correlators
FCS C2000 Leak Noise Correlators
Sewerin SeCorr Correlators
Radcom SoundSens Programmable System

Transducers (Sensors)

Various piezo-electric accelerometer types, Hydrophones and Gas Sensors are used depending upon the situation and sensitivity that is needed to find the leak.

Correlator Preamplifiers

FCS / Palmer Accu-Corr Preamplifiers
FCS MP-90 Ultrasonic Preamplifiers
Sewerin SeCorr 08 Preamplifiers

Utility Location Equipment

All suspect water main and adjacent water service lines are electronically traced during every leak location to ensure accuracy.

Magellan CX Professional	GPS Locator
Trimble TDS Recon	GPS Locator
Radiodetection Ground Penetrating Radar	
Radiodetection RD8000	Receivers
Radiodetection RD7000	Receivers
Radiodetection RD4000	Receivers
Radiodetection RD4000T10	Transmitters
Radiodetection RD433HCTx	Transmitters
CST Berger RD316	Metal Locators
Fisher FPID 2100	Metal Locators
Schonstedt GA-52CX	Metal Locators



KNOWN BY THE COMPANY WE KEEP

The clients for whom **ATS** has worked provide the best reference as to the expertise of **ATS** manpower, superior results and unmatched accuracy of **ATS Leak Detection & Location Surveys**. **ATS** surveys thousands of miles of water main and pinpoints thousands of leaks every year. The year of each city's **ATS Leak Survey** and other firms they've used are listed. We would be pleased to provide you with more references and specific details about every **ATS Leak Survey** that's listed here and those that are not on this list.

Lake County Public Works (S)

Peter E. Kolb, PE, Director of Public Works
847.377.7500
(ATS Surveys: 2012, 2013 - 12 water systems)

Village of Plainfield

Alan Persons, Director of Public Works
815.436.3577
(ATS Annual Surveys: 1985 - 2011)

Village of Palatine (P)

Jim Vlcek, Coordinator - Utilities Division
847.705.5200
(ATS Annual Surveys: 2002 - 2010)

City of St. Charles (S, W)

Paul Marschinke, Water Dept. Foreman
630.377.4463
(ATS Annual Surveys: 1990 - 2013)

City of Aurora (E, P)

Ray Hull, Director of Water Maintenance
630.844.2800
(ATS Surveys: 1996, Annually from 1999 - 2010)

Village of Hillside

Joe Pisano, Director of Public Works
708.449.6450
(ATS Bi-Annual Surveys: 1988 - 2012)

Village of Villa Park (E,S,P,W)

Vydas Juskellas, Director of Public Works
630.834.8505
(ATS Annual Surveys: 1992-96, 2000-05, 2011-12)

Village of Shorewood

Chris Drey, Supt. of Public Works
815.725.4464
(ATS Annual Surveys: 2006 - 2013)

Village of Midlothian (S)

Rick Hansen, Supt. of Public Works
708.389.9658
(ATS Surveys: 1984, 2010, 2011)

Legend: (E) = Earth Tech (Rust Environmental, Donahue); (P) = ADS Environmental Services (Severn Trent, Pitometer); (S) = ME Simpson; (W) = Water Services; (O) = Others

City of Rolling Meadows

Dan Seveska, Utilities Foreman
847.963.0500 ext. 7022
(ATS Annual Surveys: 1982 - 2013)

Village of La Grange Park (O)

Brendan McLaughlin, Director of Public Works
708.352.2922
(ATS Annual Surveys: 1981 - 2013)

Village of Elmwood Park (P)

Dino Braglia, Water Superintendent
708.452.7300
(ATS Annual Surveys: 1986-1989, 2005 - 2013)

Village of Bellwood (P, O)

Reggie Alexander (retired), Water Supervisor
708.547.3541
(ATS Annual Surveys: 1994 - 2013)

Village of Barrington

Phil Freund, Utility Supervisor
847.304.3360
(ATS Annual Surveys: 1993-96, 2001-2007, 2011-12)

Village of Wauconda (O)

Jacob Mann, Foreman - Water Division
847.526.9704
(ATS Survey: 2010, 2011, 2012, 2013)

City of New Lenox

Wayne Rassman, Water Superintendent
815.485.7589
(ATS Surveys: 1999, 2010, 2011, 2012, 2013)

Village of Grayslake

Chuck Bodden Jr, Director of Public Works
847.223.2867
(ATS Survey: 2011) Found over 1.3 MGD

Village of La Grange (S,P,W)

Mike Bojovic, Asst. Director of Public Works
708.579.2325
(ATS Surveys: 1989, '94, '98, 2000, 2001, 2011, 2013)

PROFESSIONAL HIGH TECHNOLOGY SERVICES

EMERGENCY LEAK PINPOINTING • LEAK DETECTION SURVEYS • UNDERGROUND UTILITY LOCATION • GIS / GPS MAPPING
VALVE EXERCISING • CCTV PIPE INSPECTIONS • HYDRANT TESTING • WATERMAIN FLUSHING • EQUIPMENT SALES & TRAINING

ASSOCIATED TECHNICAL SERVICES LTD

www.ATSLIMITED.com



624 W. ST. CHARLES RD. VILLA PARK, IL 60181

Office: 630.834.1558 / Fax: 630.834.5501

Established 1979

"KNOWN BY THE COMPANY WE KEEP"

The following companies have benefited from the same professional high technology services that ATS can provide for you. We therefore proudly list these fine companies as references.

AT&T Bell Laboratories	General Mills	Northwestern Univ. Medical Ctr.
Abbott Laboratories	General Motors Corporation	O'Hare International Airport
Albertsons	Gould Electronics Inc.	Olin Corporation
Alberto Culver Co.	Governors State University	Palos Community Hospital
Alcoa Aluminum	Great Lakes Naval Training Ctr.	Pepper Construction
Allstate Insurance Co.	Grinnel Fire Protection	Pepsi Co.
Amway Corp.	Helene Curtis Industries	Pfizer Inc.
American Airlines	Harper Rainey College	Praxair Inc.
Amoco Chemical Corp.	Hines VA Hospital	Purdue University
Amtrak	Holiday Inn Corp.	PPG Industries
Argonne National Laboratories	Hyatt Hotels	Quaker Oats Co.
Arlington Park Int'l Race Track	Illinois E.P.A.	Reynolds Metals
Benjamin Moore & Co.	Illinois American Water Co.	Revere Ware Corp.
Bennett & Kahnweiler	Industrial Risk Insurance	Rockwell
Bliss & Laughlin Steel Co.	Inland Steel	Rust-Oleum Corporation
Borden, Inc.	Inland Const. & Development	Safety Kleen
Borg Warner	Jewel Food Stores	Sante Fe Railway
Brookfield Zoo	Kemper Insurance	Scott Airforce Base
Brach & Sons Candy Co.	Kinder Morgan	S-K Hand Tool Corp.
Burlington Northern R.R.	Kraft Foods	Sargent Welch Scientific
Cambridge Homes	La Rabida Children's Hospital	John G. Shed Aquarium
Canfield's Beverage Co.	Lewis University	Sherwin Williams Co.
Cargill Inc.	Lincoln Park Zoo - Chicago	Shell Oil Company
Carson Pirie Scott & Co.	Lockheed Air Terminals, Inc.	State Farm Insurance
Carus Chemical Co.	Loyola University	Tootsie Roll Inc.
Center Point Properties	Loyola University Medical Ctr.	Toys R Us
Chicago Bridge & Iron	LTV Steel & LTV Aerospace	Toyota Motors Corp.
Chicago & Northwestern R.R.	Lucent Technologies	Trammell Crow Corp.
Clorox Co.	Macy's Inc.	Unichema
College of DuPage	Masonite Corporation	Unicom Thermo Technologies
College of Lake County	McDonald's Corporation	Union Carbide Corp.
Commonwealth Edison	M&M Mars Candy Inc.	Union Pacific Railroad
Comcast	Marathon Oil Company	United Airlines
Corn Products	Marriot Hotels	United Parcel Service
Del Webb Communities	McGraw Edison Company	Unocal Corp.
Dominic's Finer Foods	USGA & PGA Championships	US Gypsum
Dow Chemical	Merck Pharmaceutical	US Steel
Dresden Nuclear Power Station	Michael Reese Hospital	US Postal Service
DuPont	Midway Airport	US Army
Electro-Motive Div. of GM	Midwest Generation	US Air Force
Exelon Corporation	Mobil Oil Corporation	US Navy
Exxon Corporation	Morton Arboretum	University of Chicago
Federal Aviation Administration	Motorola	University of Illinois
Factory Mutual Insurance	Museum of Science & Industry	University of Wisconsin
Fermilab Accelerator Laboratory	Nabisco	Von Maur Department Stores
Field Museum of Natural History	Nalco Chemical Co.	Walgreens
Ford Motor Company	Navy Pier, Chicago	Waste Management
Fort Sheridan Military Base	Nestle	US Cellular Field (White Sox)
First Brands Corp.	NICOR	Wrigley Field (Cubs)
FSC Paper Co.	Northrop Grumman Corporation	Wrigley Gum Co.
General Electric	Northern Telecom	Xerox Corporation
General Foods	Northwestern University	Zenith Electronics Corp.

WATER CONSERVATION SPECIALISTS

LEAK PINPOINTING • LEAK DETECTION SURVEYS • UTILITY LOCATION • GIS / GPS MAPPING • VALVE EXERCISING PROGRAMS
CCTV INSPECTIONS • HYDRANT FLOW TESTING • UNIDIRECTIONAL WATERMAIN FLUSHING • EQUIPMENT SALES & TRAINING

Competitive Quote Summary					
Vendor	City of Darien	Package Price	Anticipated Leaks	Estimated Cost for Pinpoint of Leaks	Total Proposed Costs for City of
ADS Environmental Services	\$ 10,046.40	\$ 10,046.40	N/A	N/A	N/A
Associated Technical Services-Option A-Detection Phase	\$ 8,288.28	\$ 8,288.28			\$ 8,288.28
Location Phase-Per leak					
Pinpoint Mainline or Service Line	\$ 350.00		15	\$ 5,250.00	\$ 5,250.00
Fire Hydrant/Main line valve	\$ 95.00		10	\$ 950.00	\$ 950.00
Total Cost				\$ 6,200.00	\$ 14,488.28
Total Cost Not To Exceed					\$ 14,500.00
Edenbros, LLC	\$ 8,994.74	\$ 8,994.74	N/A	N/A	N/A
M.E. Simpson Co., Inc.	\$ 14,352.00	\$ 14,352.00	N/A	N/A	N/A

WATER LOSS / COST CHART FOR PARTIAL AND COMPLETE WATER MAIN BREAKS

Break Size: 1/16" x 180 Degrees of 360				
Pipe Diameter Per Inch	Daily Loss in Gallons	Price per 1,000 gallon-Wholesale	Annual Loss in Gallons	Annual Cost
2	45,600	\$ 3.32	16,644,000	\$ 55,258.08
4	81,400	\$ 3.32	29,711,000	\$ 98,640.52
6	136,800	\$ 3.32	49,932,000	\$ 165,774.24
8	182,400	\$ 3.32	66,576,000	\$ 221,032.32
10	228,100	\$ 3.32	83,256,500	\$ 276,411.58
12	273,700	\$ 3.32	99,900,500	\$ 331,669.66
16	364,900	\$ 3.32	133,188,500	\$ 442,185.82

Break Size: 1/16" x 360 Degrees				
Pipe Diameter Per Inch	Daily Loss in Gallons	Price per 1,000 gallon	Annual Loss in Gallons	Annual Cost
2	91,100	\$ 3.32	33,251,500	\$ 110,394.98
4	182,500	\$ 3.32	66,612,500	\$ 221,153.50
6	273,600	\$ 3.32	99,864,000	\$ 331,548.48
8	364,800	\$ 3.32	133,152,000	\$ 442,064.64
10	456,200	\$ 3.32	166,513,000	\$ 552,823.16
12	547,400	\$ 3.32	199,801,000	\$ 663,339.32
16	729,900	\$ 3.32	266,413,500	\$ 884,492.82

WATER INVENTORY (LMO) REPORTING YEAR	UNACCOUNTABLE FLOW PERCENTAGE	UNACCOUNTABLE FLOW GALLONS PER DAY	UNACCOUNTABLE FLOW GALLONS PER YEAR	WHOLESALE COST PER 1000 GALLONS	WHOLESALE COST
2013	3.18%	69,200	25,258,000	\$ 3.03	-\$76,531.74
2012	3.76%	89,232	32,569,669	\$ 2.73	-\$88,915.20
2011	1.61%	46,726	17,054,990	\$ 2.73	-\$46,560.12
2010	7.96%	191,000	69,715,000	\$ 2.73	-\$190,321.95
2009	6.40%	153,000	55,845,000	\$ 2.73	-\$152,456.85
2008	3.20%	81,000	29,565,000	\$ 2.73	-\$80,712.45
2007	1.46%	29,900	10,913,500	\$ 2.73	-\$29,793.86
2006	4.91%	102,000	37,230,000	\$ 2.73	-\$101,637.90
2005	3.80%	88,500	32,302,500	\$ 2.73	-\$88,185.83
AVERAGE	5.55%	129,080	47,114,200	\$ 2.73	-\$128,621.77

COST PER 1,000 GALLONS AVERAGED \$2.73 and \$3.32 per thousand=\$3.03

INTAKE WATER DEMAND 2011-2014 MONTHS-NOVEMBER THROUGH FEBRUARY

MONTH	NOV	DEC	JAN	FEB
YEAR	TOTAL GALLONS	TOTAL GALLONS	TOTAL GALLONS	TOTAL GALLONS
YEAR 2011	75,137,000	79,888,000	83,859,000	74,691,000
YEAR 2012	76,717,000	81,251,000	83,399,000	78,568,000
YEAR 2013	77,821,000	94,619,000	81,917,000	73,159,000
YEAR 2014	N/A	N/A	100,992,000	90,000,000

SUMMARY	MONTHLY TOTALS	161,139,000	249,175,000	226,418,000	
	Yearly Average for Based on Above Monthly Totals	80,569,500	83,058,333	75,472,666.67	
	Increased Intake Difference-Gallons	14,049,500	17,933,667	14,527,333	
	Percentage Increase	17.44%	21.59%	19.25%	19.43%

-
AGENDA MEMO
City Council
March 3, 2014

ISSUE STATEMENT

A resolution authorizing the City Administrator to execute the First Amendment to Structure Lease Agreement with General Communications dated May 16, 2013, to allow General Communications to locate a wireless dish project on the Darien Water Tank located at 1220 Plainfield Road.

RESOLUTION **BACKUP**

BACKGROUND/HISTORY

The City of Darien entered into an agreement with General Communications on May 16, 2013 to locate a total of three microwave dishes, consisting of two “projects” on the original communications tower located at 1041 S. Frontage Road. The agreement called for a \$50,000 initial capital payment and a \$8,000 monthly rental. During the due diligence and development phase with another company constructing another project, it was determined the tower could not structurally accommodate this project. General Communications investigated options to reinforce the tower to make it stronger, but in the meantime identified a way to make one of the projects work without this location. They also found additional reinforcement to the tower would be cost prohibitive. In discussions, staff asked General Communications to investigate the feasibility of moving the remaining project to Plant Two, located at 1220 Plainfield Road, so as not to lose all potential revenue associated with this project. After several months of testing and design, this location did meet the requirements of General Communications.

General Communications, paid the \$50,000 capital contribution fee and \$32,000 in rent as they moved forward with the original project in good faith. If the revised project is not accepted, the City of Darien will owe the \$82,000 back to General Communications. With this new offer, General Communications pays a capital contribution and the remainder of the money is used to abate rent to the City of Darien beginning November 2013.

STAFF/COMMITTEE RECOMMENDATION

Staff recommends approving the resolution

ALTERNATE CONSIDERATION

Not approving the resolution and refunding \$82,000 would be an alternate consideration.

RESOLUTION NO. _____

A RESOLUTION AUTHORIZING THE CITY ADMINISTRATOR TO EXECUTE THE FIRST AMENDMENT TO STRUCTURE LEASE AGREEMENT WITH GENERAL COMMUNICATIONS DATED MAY 16, 2013, TO ALLOW GENERAL COMMUNICATIONS TO LOCATE A WIRELESS DISH PROJECT ON THE DARIEN WATER TANK LOCATED AT 1220 PLAINFIELD ROAD

BE IT RESOLVED BY THE CITY COUNCIL OF THE CITY OF DARIEN, DU PAGE COUNTY, ILLINOIS, as follows:

SECTION 1: The City Council of the City of Darien hereby authorizes the City Administrator to execute the First Amendment to Structure Lease Agreement with General Communications dated May 16, 2013, to allow General Communications to locate a wireless dish project on the Darien Water Tank located at 1220 Plainfield Road, attached hereto as "[Exhibit A](#)".

SECTION 2: This Resolution shall be in full force and effect from and after its passage and approval as provided by law.

PASSED BY THE CITY COUNCIL OF THE CITY OF DARIEN, DU PAGE COUNTY, ILLINOIS, this 3rd day of March, 2014.

AYES: _____

NAYS: _____

ABSENT: _____

APPROVED BY THE MAYOR OF THE CITY OF DARIEN, DU PAGE COUNTY, ILLINOIS, this 3rd day of March, 2014.

KATHLEEN MOESLE WEAVER, MAYOR

ATTEST:

JOANNE E. RAGONA, CITY CLERK

APPROVED AS TO FORM:

CITY ATTORNEY

Site Name: _____

Site Number: _____

FIRST AMENDMENT TO STRUCTURE LEASE AGREEMENT

This First Amendment to Structure Lease Agreement (this “**First Amendment**”) is made this ___ day of _____, 2014, between The City of Darien, an Illinois municipal corporation (hereinafter referred to as “**Landlord**”) and General Communications, LLC, a Delaware limited liability company (hereinafter referred to as “**Tenant**”).

R E C I T A L S:

A. Pursuant to that certain Structure Lease Agreement executed by Landlord and Tenant on or about May 16, 2013 (the “**Structure Lease**”) by and between Landlord and Tenant, Landlord demised and leased to Tenant the Premises, which is comprised of the Equipment Space, the Antenna Space, Connections, Access, and Right of Way (as each of such terms are defined in the Structure Lease) at the property commonly known as 1041 Frontage Road, Darien, Illinois (the “**Original Site**”).

B. Landlord and Tenant have agreed, among other things, to relocate the Premises from the Original Site to a new location at 1220 Plainfield Road, Darien, Illinois on which the Darien Water Tank – Plant #2 is located.

C. The Structure Lease originally contemplated three antennas and Tenant has agreed that, under the Structure Lease, as revised by this First Amendment, will have only two antennas. The Structure Lease also originally contemplated a custom dual dish tower mount which Tenant has removed, under the Structure Lease, as revised by this First Amendment.

D. Landlord and Tenant desire to amend the Structure Lease in the manner provided below.

NOW THEREFORE, in consideration of the foregoing premises, and of the mutual promises contained herein, the Structure Lease is hereby amended as follows:

1. Capitalized terms used but not defined in this First Amendment have the respective meanings given to such terms in the Structure Lease.

2. Landlord represents and warrants that Landlord owns or controls that certain plot, parcel or tract of land, improved with a water tank on which Tenant’s antennas and related equipment can be installed (the “**Tower**”), together with all rights and privileges arising in connection therewith, located at 1220 Plainfield Road, in the City of Darien, in the County of DuPage, State of Illinois 60561 as more fully described on **Exhibit 1** (collectively, the “**Property**”). Landlord and Tenant agree that, from and after the date of this First Amendment, the term Property shall mean, for all purposes of the Structure Lease, the Tower and other property described in this Section 2.

3. Section 1(a) of the Lease is hereby amended and restated in its entirety as follows:

“**1. PREMISES.**

(a) Landlord hereby leases to Tenant a portion of the Property consisting of:

(i) **ground area space of approximately 12 square feet for Tenant's equipment shelter ("Equipment Space")** and

(ii) vertical space on the Tower ("**Antenna Space**"), together with such easements as are necessary for installation, operation and maintenance of Tenant's antennas as described on attached **Exhibit 2** ; and

(iii) those certain areas where Tenant's conduits, wires, cables, cable trays and other necessary connections are located between the Equipment Space and the Antenna Space, and between the Equipment Space and the electric power, telephone, and fuel sources for the Property (hereinafter collectively referred to as "**Connections**"). Landlord agrees that Tenant shall have the right to install Connections between Tenant's equipment in the Equipment Space and Antenna Space; and between Tenant's equipment in the Equipment Space and the electric power, telephone, and fuel sources for the Property, and any other improvements. Landlord further agrees that Tenant shall have the non-exclusive right for ingress and egress to the Premises (as hereinafter defined), seven (7) days a week, twenty-four (24) hours a day, on foot or motor vehicle, including trucks, over such portion of the Premises as may be designated by the Landlord extending from the nearest public right-of-way to the Premises, together with the right to install, replace and maintain utility wires, poles, cables, conduits, pipes and other necessary connections over or along any right-of-way extending from the aforementioned public right-of-way to the Premises. Notwithstanding the foregoing, Tenant, to the extent feasible, shall locate all wires, conduits and cables on existing poles extending from the roadway into Landlord's Property. The Equipment Space, Antenna Space, Connections, Access, and Right-of-Way are hereinafter collectively referred to as the "**Premises**".

4. The parties acknowledge that Tenant did not receive an irrevocable Notice to Proceed to install its antennas and other equipment in and on the Original Site. Accordingly, the parties have agreed to extend the commencement date of the Initial Term, as provided in Section 3(a) of the Structure Lease, from June 1, 2013 until the first day of the month following the date on which an irrevocable Notice to Proceed is issued for the installation of the antennas and other equipment described on **Exhibit 2** to this First Amendment (the "**Revised Commencement Date**"). The Initial Term of the Structure Lease is subject to extension for the Extension Terms as provided in Article 3 of the Structure Lease.

5. The monthly Rent payable during the Initial Term of the Structure Lease is hereby reduced from eight thousand and No/100 Dollars (\$8,000.00) to four thousand and No/100 Dollars (\$4,000.00), which reduction in monthly Rent is effective automatically. Tenant has previously paid rent under the Structure Lease from July through October 2013 in the aggregate amount of \$32,000.00. Landlord and Tenant agree that this \$32,000 shall be applied as follows: (a) \$16,000 will be applied to rent payable under that certain Structure Lease Agreement

executed by Landlord and Tenant on or about December 11, 2011 (the “**Previous Lease**”) for rent payable under the Previous Lease for the period commencing on November 1, 2013 and ending February 28, 2014; and (b) \$16,000 shall be applied to monthly Rent payable under the Structure Lease for the four (4) month period commencing on the Revised Commencement Date of the Structure Lease (the “**Prepaid Rent Period**”).

6. Landlord acknowledges that Tenant also has made the \$50,000.00 capital contribution contemplated by Section 4(d) of the Structure Lease and that the amount of such capital contribution is being and is hereby reduced to \$25,000.00 in connection with the relocation of the Premises from the Original Site to the Property. Landlord agrees that Tenant may apply the \$25,000.00 overpayment to monthly Rent due and owing from and after the expiration of the Prepaid Rent Period until such time as such \$25,000.00 overpayment has been fully applied to the payment of monthly Rent under the Structure Lease.

7. Except as amended and modified by this First Amendment, the Structure Lease remains unmodified and in full force and effect.

8. This First Amendment may be executed in one or more counterparts, each of which will for all purposes be deemed to be an original and all of which taken together shall constitute one and the same original instrument.

IN WITNESS WHEREOF, Landlord and Tenant have executed this First Amendment on the day and year first above written.

LANDLORD:

The City of Darien, an Illinois municipal corporation

By: _____
Name: _____
Its: _____
Date: _____

TENANT:

General Communications LLC, a Delaware limited liability company

By: _____
Name: _____
Title: _____
Date: _____

Site Name: _____

Site Number: _____

Exhibit 1

The Property

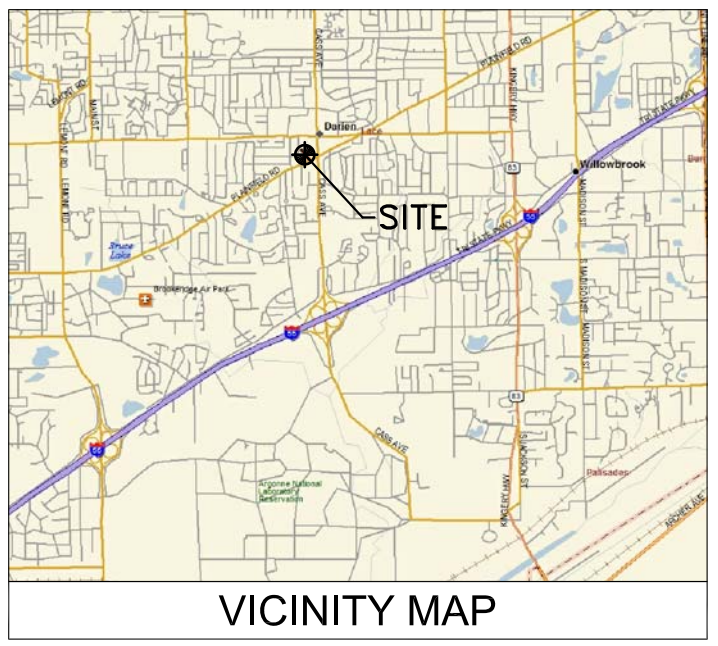

VICINITY MAP



comtineo
MANAGED SERVICES

SITE NAME: PLANT NO. 2
SITE NUMBER: TBD

1220 PLAINFIELD RD
DARIEN, IL 60561



AERIAL MAP



UNDERGROUND SERVICE ALERT
OHIO UTILITY PROTECTION SERVICE
1.800.362.2764
811

3 WORKING DAYS UTILITY NOTIFICATION PRIOR TO CONSTRUCTION

THIS FACILITY SHALL MEET OR EXCEED ALL
FAA AND FCC REGULATORY REQUIREMENTS

REV.	DATE	DESCRIPTION
A	02/21/14	ISSUED FOR 90% REVIEW
B	02/24/14	REVISED PER COMMENTS

PROJECT TEAM	PROJECT SUMMARY	PROJECT DESCRIPTION	SHEET INDEX				
ARCHITECT: GPD GROUP 520 SOUTH MAIN ST, SUITE 2531 AKRON, OH 44311 TEL: 330-572-2100 FAX: 330-572-2101 CUSTOMER: COMTINEO P.O. BOX 1536 VALPARAISO, IN 46384 CONTACT: KEVIN J BABICH TEL: (219) 476-3133 ZONING/PERMITTING CONTACT: COMTINEO P.O. BOX 1536 VALPARAISO, IN 46384 CONTACT: KEVIN J BABICH TEL: (219) 476-3133 LANDLORD: TBD TBD TBD TEL: TBD FAX: TBD GROUND OWNER: CITY OF DARIEN PUBLIC WORKS 1041 S FRONTAGE RD DARIEN, IL 60561 POWER COMPANY: TBD TEL: TBD TELCO COMPANY: TBD TEL: TBD	SITE NAME: PLANT NO. 2 SITE NUMBER: TBD SITE ADDRESS: 1220 PLAINFIELD RD DARIEN, IL 60561 USE: WATER TANK GEOGRAPHIC COORDINATES: LATITUDE: 41° 44' 58.6458" N 41.749624° N LONGITUDE: 87° 58' 33.7650" W -87.976046° W GROUND ELEVATION: 763 FT. ZONING AND BUILDING PERMIT: ZONING JURISDICTION: CITY OF DARIEN PARCEL ID: 0928402020 ZONING CLASSIFICATION: E WATER SUPPLY: NONE WASTE WATER: NONE BUILDING CODE & STANDARDS 2009 INTERNATIONAL BUILDING CODE	PROPOSED PROJECT INCLUDES INSTALLATION OF (2) PROPOSED MICROWAVE DISHES	SHT NO: T-1	DESCRIPTION: TITLE SHEET, VICINITY MAP AND GENERAL INFORMATION	REV: A	DATE: 02-24-14	BY: SEK
		PROJECT NOTES <ol style="list-style-type: none"> THE FACILITY IS UNMANNED. A TECHNICIAN WILL VISIT THE SITE APPROXIMATELY ONCE A MONTH FOR ROUTINE INSPECTION AND MAINTENANCE. THE PROJECT WILL NOT RESULT IN ANY SIGNIFICANT LAND DISTURBANCE OR EFFECT OF STORM WATER DRAINAGE.. NO SANITARY SEWER, POTABLE WATER, OR TRASH DISPOSAL IS REQUIRED. HANDICAP ACCESS IS NOT REQUIRED. 	C-1	SITE PLAN	A	02-24-14	SEK
		PROJECT LOCATION DIRECTIONS HEAD SOUTHWEST ON I-55 S TOWARD EXIT 274. TAKE EXIT 273B TOWARD N CASS AVE. MERGE ONTO S CASS AVE. TURN LEFT ONTO PLAINFIELD RD. SITE WILL BE LOCATED ON THE RIGHT.	C-2	TOWER ELEVATION	A	02-24-14	SEK
SITE ACCESS INFORMATION CALL PUBLIC WORKS SCOTT COREN CITY OF DARIEN ASSISTANT CITY ADMINISTRATOR (630) 353-8104 (630) 852-4709 FAX SCOREN@DARIENIL.GOV	C-2A	MICROWAVE SCHEDULE & MOUNT DETAILS	A	02-24-14	SEK		
GENERAL DRAWING SUPPLEMENT	C-3	MOUNT DETAILS	A	02-24-14	SEK		
	E-1	ELECTRICAL SITE PLAN & SINGLE LINE	A	02-24-14	SEK		
	E-1	GROUNDING SCHEMATIC DIAGRAM	A	02-24-14	SEK		
	GN-1	GENERAL NOTES	A	02-24-14	SEK		

PLANT NO. 2
1220 PLAINFIELD RD
DARIEN, IL 60561

TITLE SHEET, VICINITY MAP AND GENERAL INFORMATION

ISSUED FOR:	
REVIEW	-
PERMIT	-
CONSTRUCTION	-
RECORD	-

PROJECT MANAGER	DESIGNER
TS	SEK

JOB NO.
2014708.01

T-1

Drawing Name: 032014\201470801 Comtineo Darrien\CDs\Comtineo CDs.dwg
February 24, 2014 4:58 PM - smlschmer

REV.	DATE	DESCRIPTION
A	02/21/14	ISSUED FOR 90% REVIEW
B	02/24/14	REVISED PER COMMENTS

PLANT NO. 2
 1220 PLAINFIELD RD
 DARIEN, IL 60561

SITE PLAN

ISSUED FOR:	
REVIEW	-
PERMIT	-
CONSTRUCTION	-
RECORD	-

PROJECT MANAGER	DESIGNER
TS	SEK

JOB NO.
2014708.01

C-1

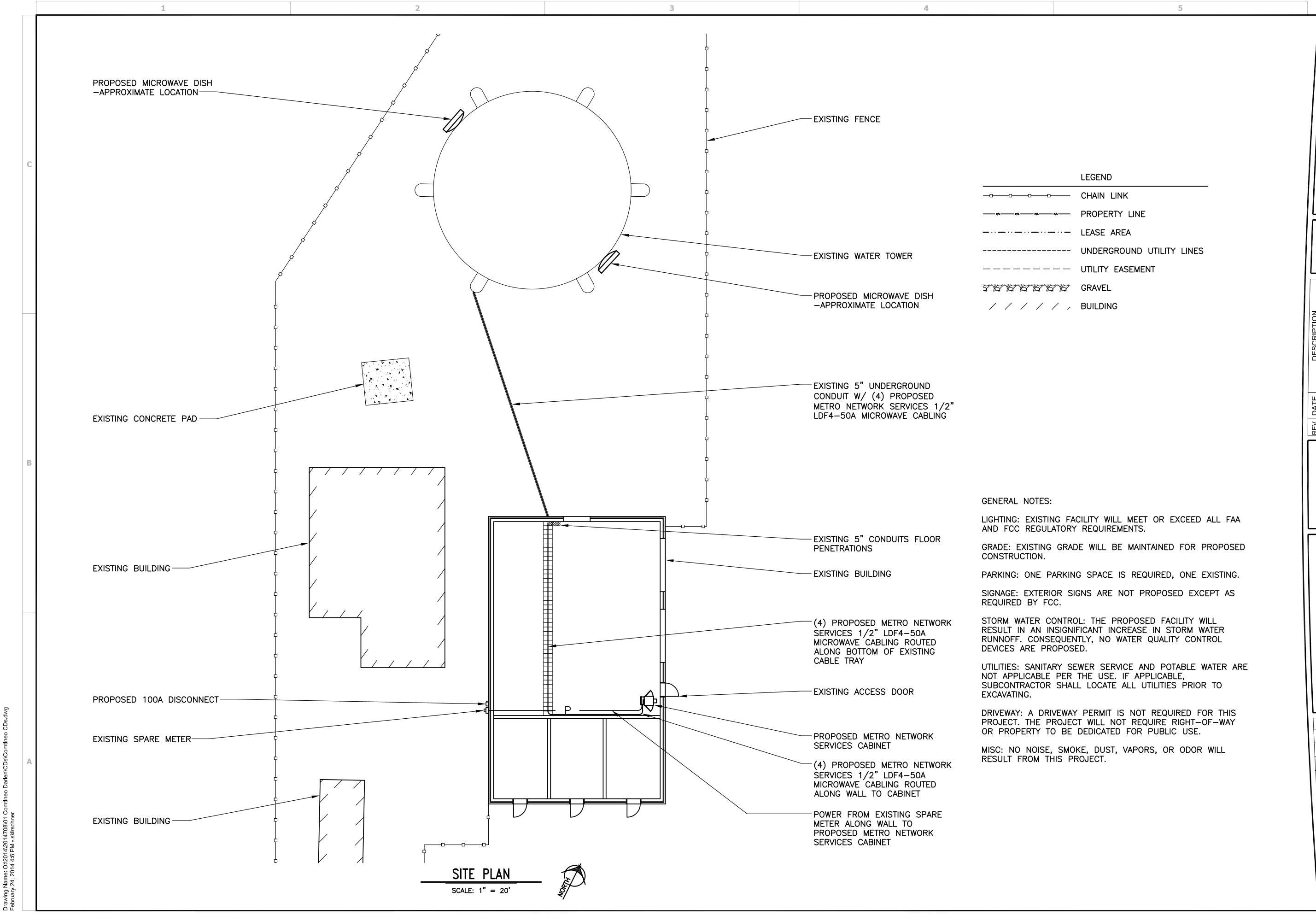

Drawing Name: O:\2014\201470801 Comtineo Darien\CDs\Comtineo CDs.dwg
 February 24, 2014 4:58 PM - smlschmer

REV.	DATE	DESCRIPTION
A	02/21/14	ISSUED FOR 90% REVIEW
B	02/24/14	REVISED PER COMMENTS

PLANT NO. 2
 1220 PLAINFIELD RD
 DARIEN, IL 60561

TOWER ELEVATION

ISSUED FOR:	
REVIEW	-
PERMIT	-
CONSTRUCTION	-
RECORD	-

PROJECT MANAGER	DESIGNER
TS	SEK

JOB NO.
2014708.01

C-2

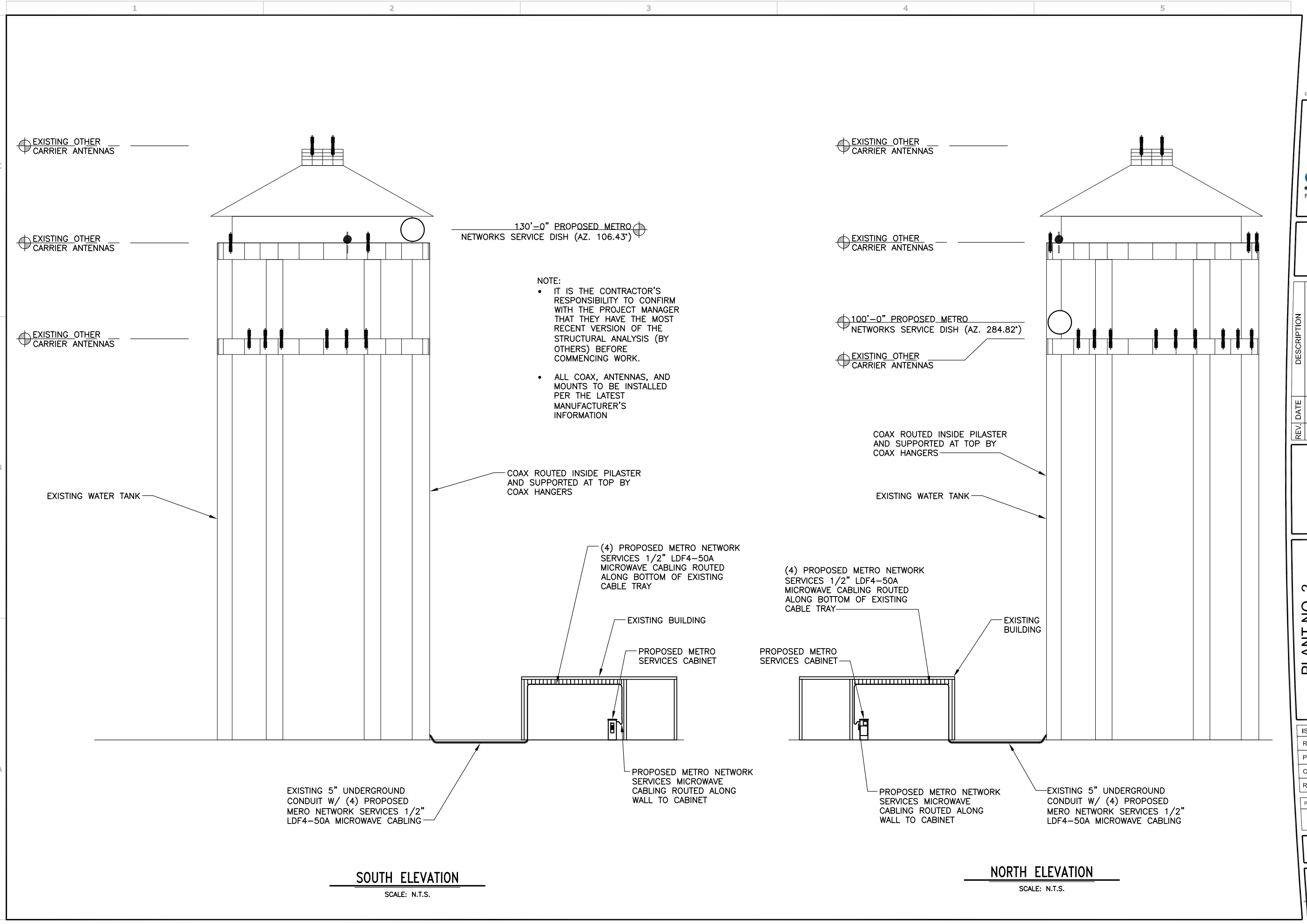

Drawing Name: 032014201470801 Comtineo Darien\CDs\Comtineo CDs.dwg
 February 24, 2014 4:18 PM - smlschner

ANTENNA SPECIFICATION TABLE		
ITEM	DISH #1	DISH #2
ANTENNA PER SECTOR	1	1
ANTENNA MODEL	UHX6-59K RF	UHX6-65F RF
LICENSED FREQUENCIES V/H	6286.19 / 6404.79	11445 / 11565
CONFIGURATION	2+0	2+0
ANTENNA CENTER LINE	100'-0"	130'-0"
SITE AZIMUTH	284.82°	106.43°
PATH DISTANCE	13.9 Miles	24.8 Miles
RADIO TYPE	CGX6_30_167Mb	CGX11_30_167Mb
RADIO TRAFFIC CODE	167Mbps_30Mhz	167Mbps_30Mhz
MAIN LINE TYPE	LDF4-50A	LDF4-50A
MAIN LINE RUNS (PER ANTENNA)	2	2
MAIN LINE LENGTH	250'-0"	270'-0"
TOP JUMPER (FT)	3'-0"	3'-0"
BOTTOM JUMPER LENGTH (FT)	3'-0"	3'-0"

REV.	DATE	DESCRIPTION
A	02/21/14	ISSUED FOR 90% REVIEW
B	02/24/14	REVISED PER COMMENTS

PLANT NO. 2
1220 PLAINFIELD RD
DARIEN, IL 60561

**MICROWAVE SCHEDULE
& MOUNT DETAILS**

ISSUED FOR:	
REVIEW	-
PERMIT	-
CONSTRUCTION	-
RECORD	-

PROJECT MANAGER	DESIGNER
TS	SEK

JOB NO.
2014708.01

C-2A

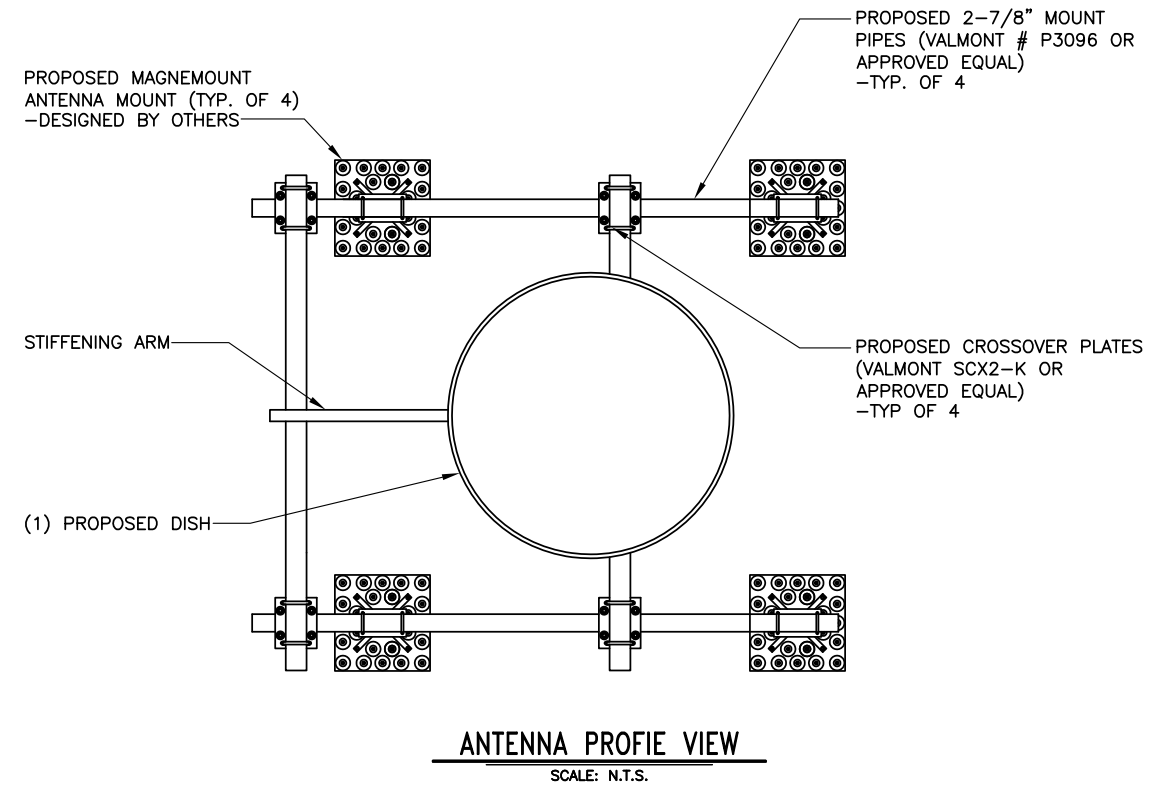
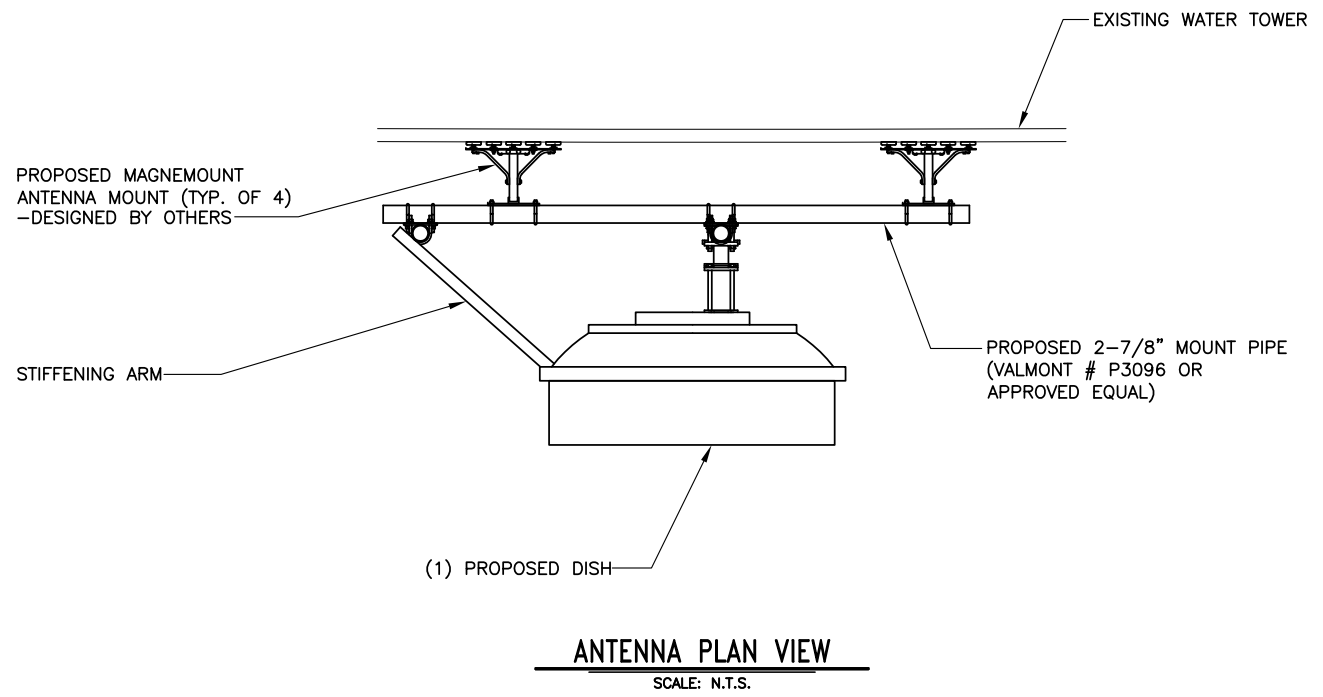

NOTE:
 THIS DETAIL IS FOR REPRESENTATION ONLY. THE
 NUMBER OF ANTENNAS, DISHES, ODU AND COAX
 SHOULD BE DETERMINED BY REFERENCING THE
 RF CONFIGURATION CHART ON PAGE A-2.



ISOMETRIC VIEW

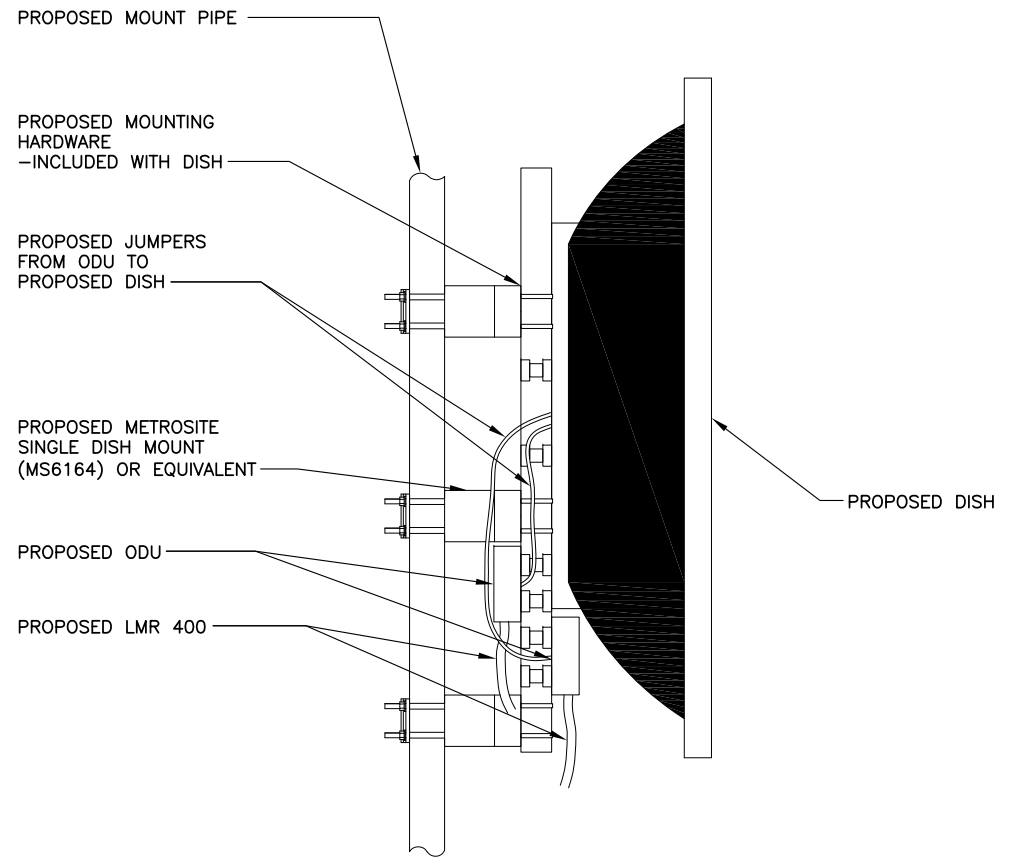

NOTE:
 MOUNT ODU'S IN
 ANTENNA WIND SHADOW

PIPE MOUNT ELEVATION
 SCALE: N.T.S.

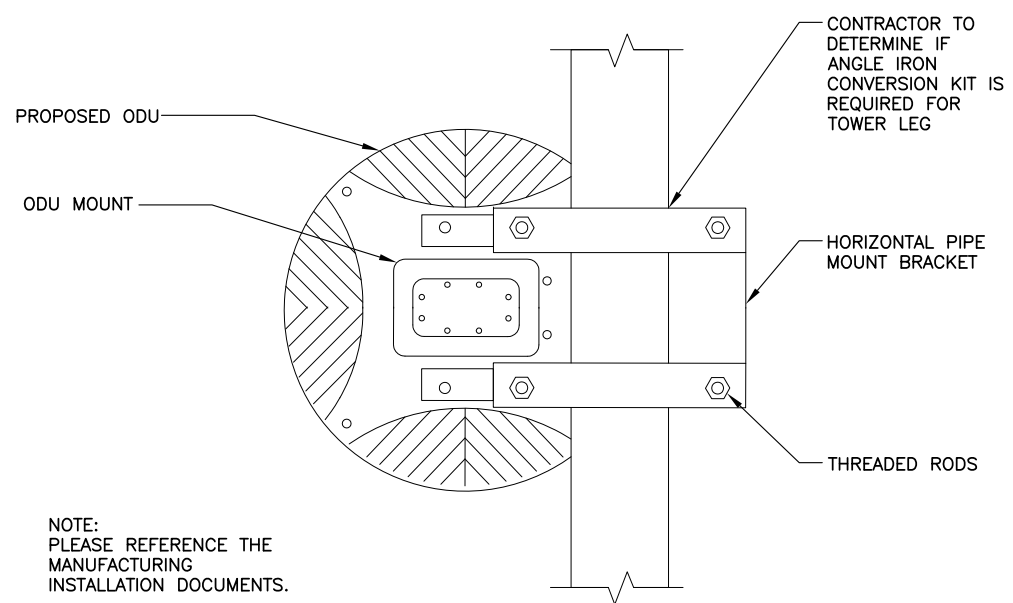

NOTE:
 PLEASE REFERENCE THE
 MANUFACTURING
 INSTALLATION DOCUMENTS.

ODU MOUNT
 SCALE: N.T.S.

REV.	DATE	DESCRIPTION
A	02/21/14	ISSUED FOR 90% REVIEW
B	02/24/14	REVISED PER COMMENTS

PLANT NO. 2
 1220 PLAINFIELD RD
 DARIEN, IL 60561

MOUNT DETAILS

ISSUED FOR:	
REVIEW	-
PERMIT	-
CONSTRUCTION	-
RECORD	-
PROJECT MANAGER	DESIGNER
TS	SEK

JOB NO.
 2014708.01

GENERAL NOTES

1. WIRING SHALL BE AWG STRANDED COPPER WITH THHN OR EQUIVALENT INSULATION. #12 MINIMUM INSTALLED IN 1/2" MINIMUM CONDUIT. SIGNAL WIRING SHALL BE INSULATED #22 AWG. NO BX OR ROMEX CABLE IS PERMITTED. CONDUITS SHALL BE SURFACE MOUNTED.
2. WIRING DEVICES AND EQUIPMENT SHALL BE UL LISTED SPECIFICATIONS GRADE.
3. MATERIALS SHALL BE NEW AND CONFORM TO THE APPLICABLE STANDARDS ESTABLISHED FOR EACH ITEM BY THE ORGANIZATIONS LISTED BELOW.
 -AMERICAN SOCIETY FOR TESTING MATERIALS (ASTM)
 -UNDERWRITER'S LABORATORY (UL)
 -NATIONAL ELECTRICAL MANUFACTURERS ASSOCIATION (NEMA)
 -AMERICAN STANDARDS ASSOCIATION (ASE)
 -NATIONAL FIRE PROTECTION ASSOCIATION (NFPA)
4. INSTALLATION OF MATERIALS SHALL COMPLY WITH REGULATIONS OF:
 -THE NATIONAL ELECTRIC CODE (NFPA 70)
 -THE NATIONAL ELECTRIC SAFETY CODE (ANSI C-2)
 -LOCAL BUILDING CODES
5. THE ENTIRE SYSTEM SHALL BE SOLIDLY GROUNDED USING LOCKOUTS AND BONDING NUTS ON CONDUITS AND PROPERLY BONDED GROUND CONDUCTORS. RECEPTACLES AND EQUIPMENT BRANCH CIRCUITS SHALL BE GROUNDED WITH A FULL-SIZED EQUIPMENT GROUNDING CONDUCTOR RUN IN THE CIRCUITS CONDUITS.
6. OUTLET AND JUNCTION BOXES SHALL BE ZINC-COATED OR CADMIUM PLATED STEEL NOT LESS THAN 4" SQUARE AND SUITABLE FOR THE TYPE SERVICE AND OUTLET. OUTLET AND JUNCTION BOXES SHALL BE SURFACE MOUNTED FOR LABELED WITH BRANCH CIRCUIT BREAKER NUMBER.
7. LABEL ALL EQUIPMENT SERVED FROM PANELBOARD WITH PHENOLIC LABELS SIZED IN RELATION TO USAGE.
8. INDOOR CONDUCTORS SHALL BE INSTALLED IN EMT UNLESS NOTED OTHERWISE. OUTDOOR CONDUCTORS SHALL BE INSTALLED IN RIGID GALVANIZED STEEL UNLESS NOTED OTHERWISE. WHERE EMT IS USED, IT SHALL BE WITH ONLY LISTED COMPRESSION FITTINGS. NO SET SCREW FITTINGS SHALL BE ALLOWED.
9. CONTRACTOR TO PROVIDE AND INSTALL ENGRAVED LABEL ON THE METER SOCKET ENCLOSURE.

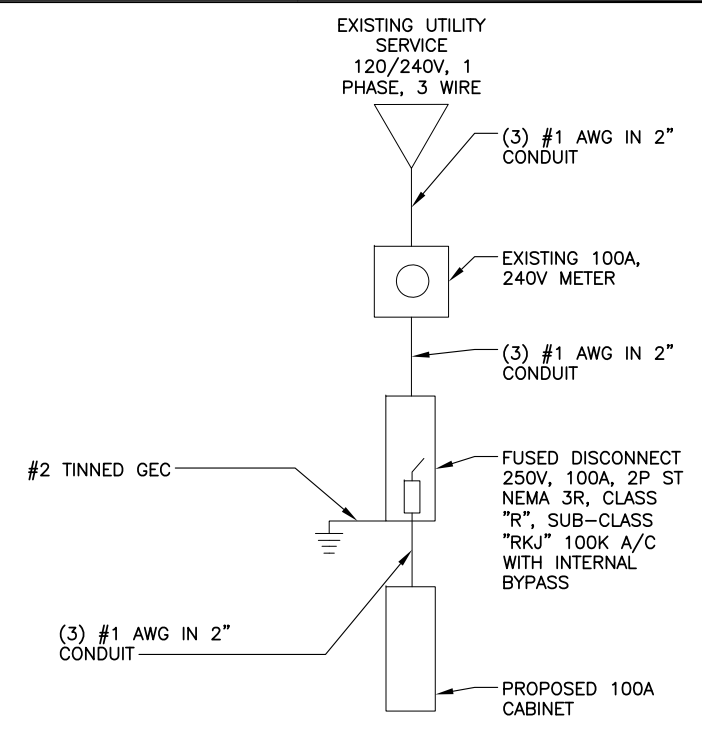

ONE LINE DIAGRAM
 SCALE: N.T.S.

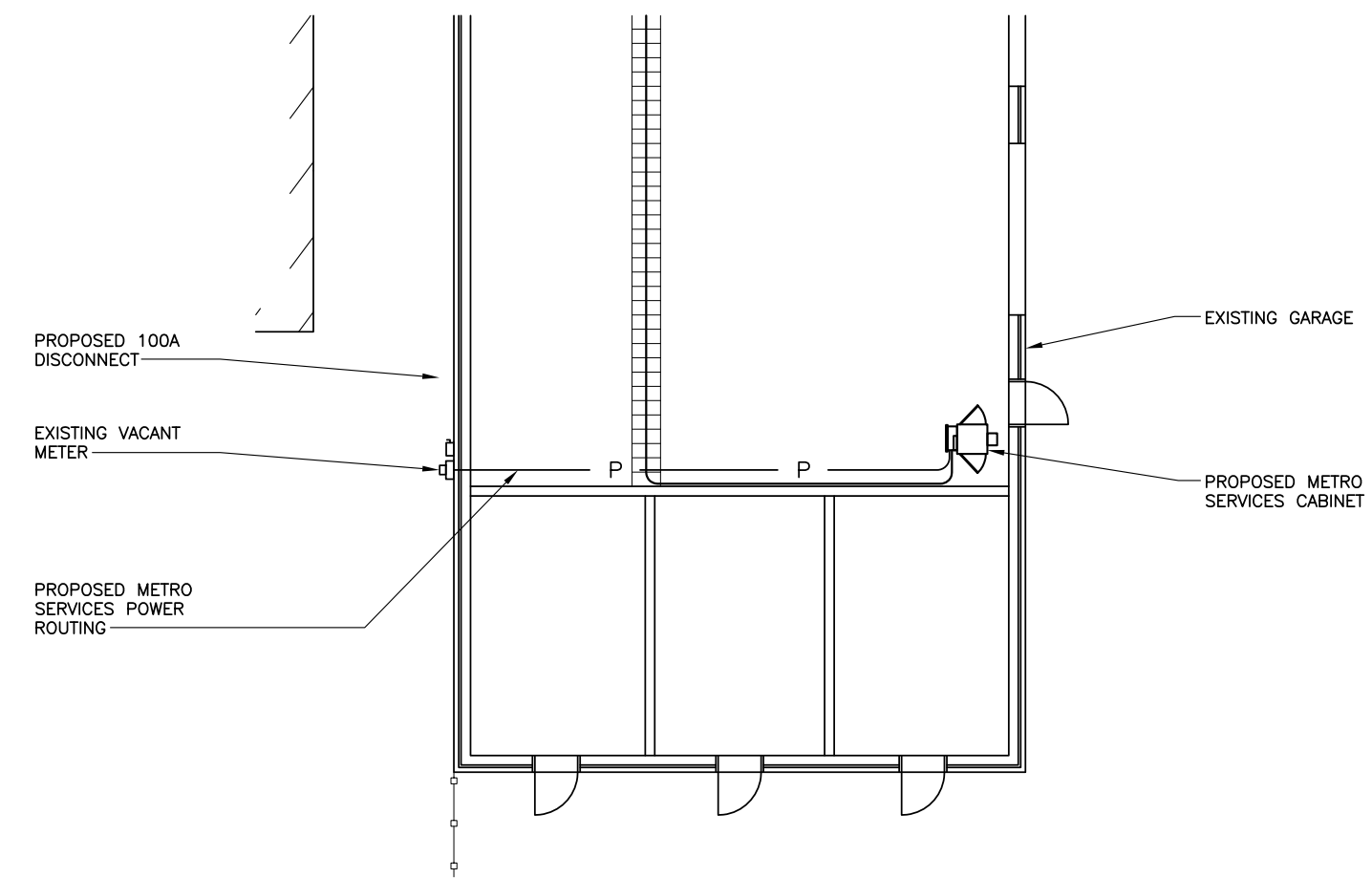

ELECTRICAL SITE PLAN
 SCALE: N.T.S.

REV.	DATE	DESCRIPTION
A	02/21/14	ISSUED FOR 90% REVIEW
B	02/24/14	REVISED PER COMMENTS

PLANT NO. 2
 1220 PLAINFIELD RD
 DARIEN, IL 60561
ELECTRICAL SITE PLAN

ISSUED FOR:	
REVIEW	-
PERMIT	-
CONSTRUCTION	-
RECORD	-

PROJECT MANAGER	DESIGNER
TS	SEK

JOB NO.
2014708.01

E-1

REV.	DATE	DESCRIPTION
A	02/21/14	ISSUED FOR 90% REVIEW
B	02/24/14	REVISED PER COMMENTS

PLANT NO. 2
 1220 PLAINFIELD RD
 DARIEN, IL 60561

GROUNDING SCHEMATIC DIAGRAM

ISSUED FOR:	
REVIEW	-
PERMIT	-
CONSTRUCTION	-
RECORD	-

PROJECT MANAGER	DESIGNER
TS	SEK

JOB NO.
2014708.01

E-2

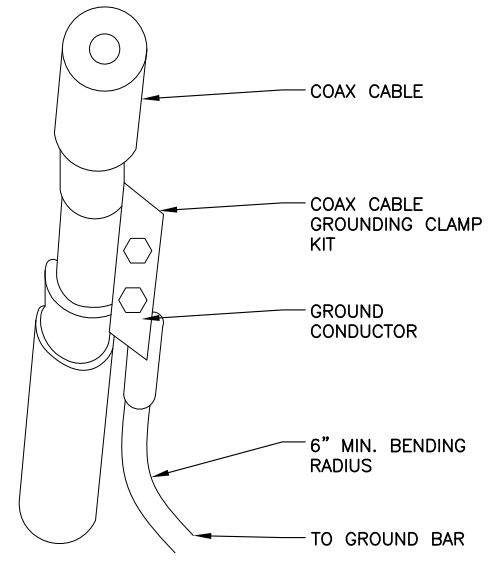

COAX CABLE GROUNDING
 SCALE: N.T.S.

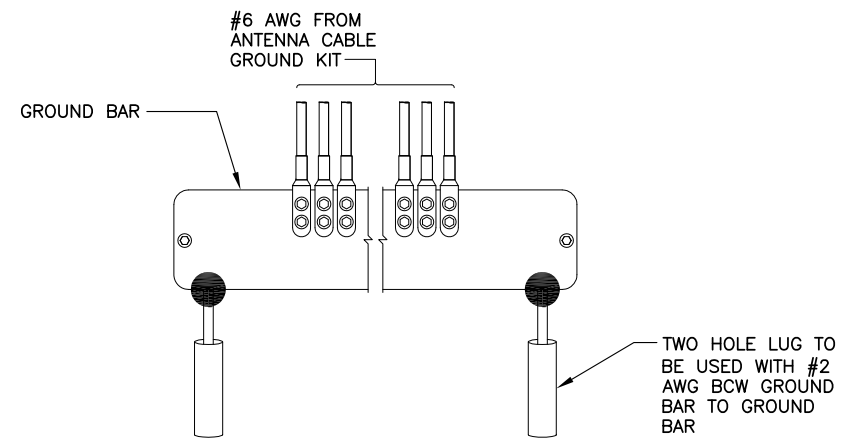

GROUNDING BAR DETAIL
 SCALE: N.T.S.

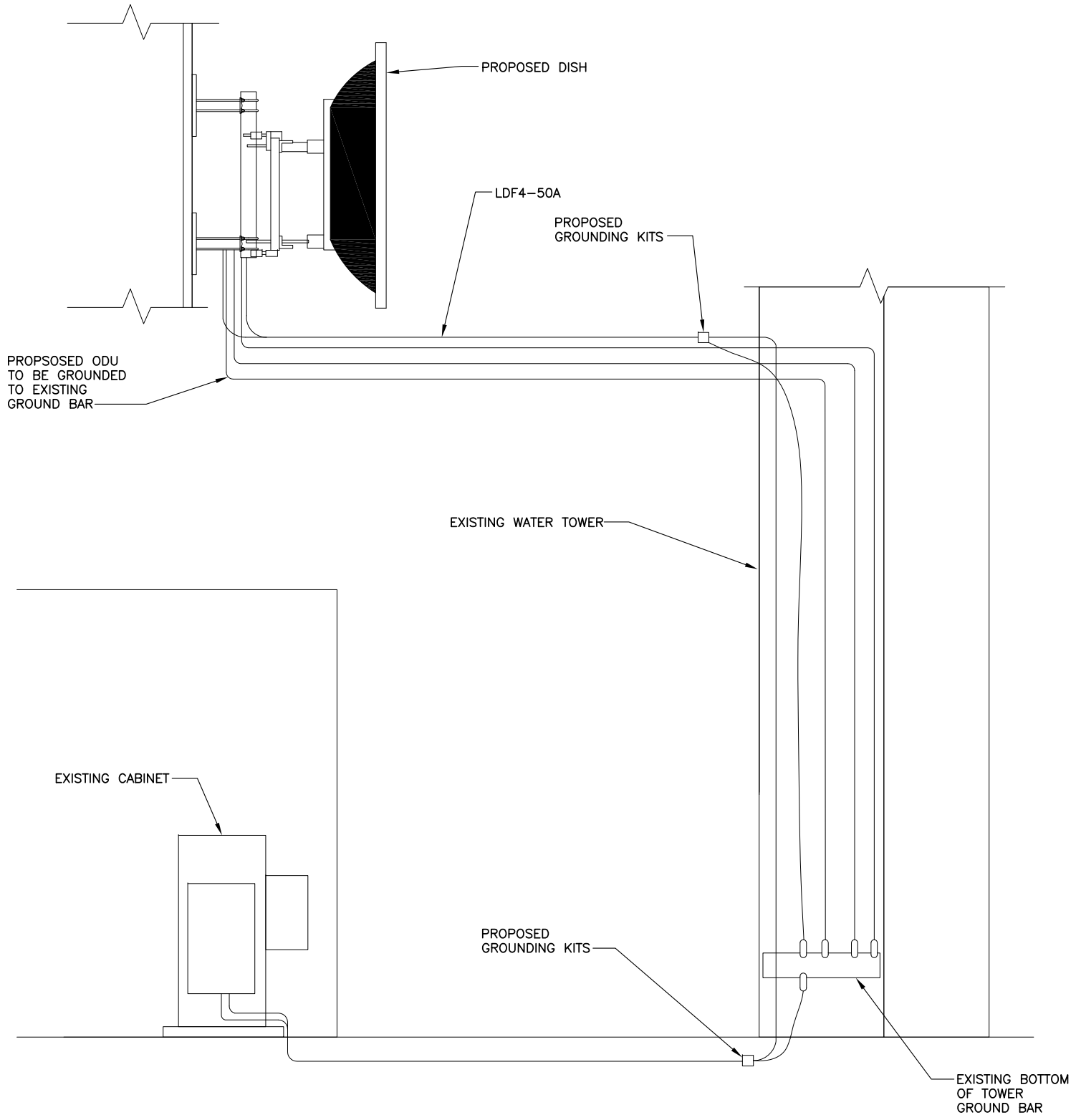

NOTE:
 THIS DETAIL IS FOR GROUNDING REPRESENTATION ONLY. THE NUMBER OF DISHES AND COAX SHOULD BE DETERMINED BY REFERENCING THE FINAL RF CONFIGURATIONS CHART ON PAGE A-2.

HAND DIG AS REQUIRED TO PROTECT ALL EXISTING UNDERGROUND UTILITIES

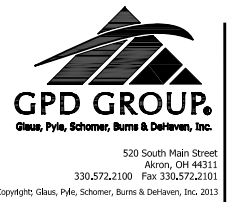

1.0 GENERAL REQUIREMENTS (AS REQUIRED)

1) GENERAL SPECIFICATIONS

- a. ALL REFERENCES TO THE OWNER IN THESE DOCUMENTS SHALL BE CONSIDERED CUSTOMER OR ITS DESIGNATED REPRESENTATIVE
- b. WORK SHALL COMPLY WITH ALL APPLICABLE CODES, ORDINANCES, AND REGULATIONS. ALL NECESSARY LICENSES, CERTIFICATES, PERMITS, ETC., REQUIRED BY AUTHORITY HAVING JURISDICTION SHALL BE PROCURED AND PAID FOR BY THE CONTRACTOR.
- c. ALL WORK PRESENTED IN THESE DRAWINGS MUST BE COMPLETED BY THE CONTRACTOR UNLESS NOTED OTHERWISE. THE CONTRACTOR MUST HAVE CONSIDERABLE EXPERIENCE IN THE PERFORMANCE OF WORK SIMILAR TO DO THAT DESCRIBED HEREIN BY ACCEPTANCE OF THIS AGREEMENT. THE CONTRACTOR ATTESTS THAT HE DOES HAVE SUFFICIENT EXPERIENCE AND ABILITY TO COMPLETE THE WORK THAT HE IS KNOWLEDGEABLE OF THE WORK TO BE PERFORMED AND THAT HE IS PROPERLY LICENSED AND PROPERLY REGISTERED TO DO THIS WORK.
- d. THE GENERAL CONTRACTOR AND EACH SUBCONTRACTOR SHALL BE RESPONSIBLE FOR VERIFYING DIMENSIONS AND CONDITIONS AT THE JOB SITE WHICH COULD AFFECT THE WORK UNDER THIS CONTRACT, ALL MANUFACTURERS RECOMMENDED SPECIFICATIONS, EXCEPT THOSE SPECIFICATIONS HEREIN, WHERE MOST STRINGENT SHALL BE COMPLIED WITH.
- e. DO NOT SCALE THE DRAWINGS. DIMENSIONS ARE EITHER TO THE FACE OF FINISHED ELEMENTS OR TO THE CENTER LINE OF THE ELEMENTS, UNLESS NOTED OTHERWISE. CRITICAL DIMENSIONS SHALL BE CONFIRMED WITH SIRE MEASUREMENTS. VERIFY WITH OWNER AS APPLICABLE.
- f. WHERE ONE DETAIL IS SHOWN FOR ONE CONDITION, UNLESS NOTED OTHERWISE, IT SHALL APPLY FOR ALL LIKE OR SIMILAR CONDITIONS, EVEN THOUGH NOT SPECIFICALLY MARKED ON THE DRAWINGS.
- g. DRAWINGS FORMING THIS SET ARE COMPLIMENTARY AND MUST BE READ AS ONE TOTAL DOCUMENT. DRAWINGS AND SPECIFICATIONS ARE THE PROPERTY OF THE OWNER. THESE DRAWINGS WERE PREPARED TO BE SUBMITTED TO GOVERNMENTAL BUILDING AUTHORITIES FOR REVIEW FOR COMPLIANCE WITH APPLICABLE CODES. IT IS THE SOLE RESPONSIBILITY OF THE CONTRACTOR TO EXECUTE CONSTRUCTION INDICATED HEREIN ACCORDING TO THE APPLICABLE BUILDING CODES.
- h. THE SCOPE OF WORK SHALL INCLUDE FURNISHING ALL MATERIALS, EQUIPMENT, AND LABOR DEEMED NECESSARY TO COMPLETE THE WORK/PROJECT DESCRIBED HEREIN.
- i. THE CONTRACTOR SHALL OBTAIN AUTHORIZATIONS FROM THE OWNER TO PROCEED WITH CONSTRUCTION PRIOR TO STARTING WORK ON ANY ITEM NOT CLEARLY DEFINED BY THE CONSTRUCTION DRAWINGS/CONTRACT DOCUMENTS.

2) MATERIALS

- a. WHERE PAVING, CONCRETE SIDEWALKS OR PATHS MEET EXISTING CONSTRUCTION, THE CONTRACTOR SHALL MATCH THE EXISTING PITCH, GRADE, AND ELEVATION SO THE ENTIRE STRUCTURE SHALL HAVE A SMOOTH TRANSITION.
- b. THE CONTRACTOR SHALL MAKE NECESSARY PROVISIONS TO PROTECT AND MAINTAIN EXISTING CONDITIONS, EASEMENTS, PAVEMENTS, CURBING, ETC. DURING CONSTRUCTION. UPON COMPLETION OF WORK, THE CONTRACTOR SHALL REPAIR ANY DAMAGES THAT MAY HAVE OCCURRED DUE TO CONSTRUCTION ON OR ABOUT THE PROPERTY.
- c. ALL MATERIALS FURNISHED SHALL BE NEW AND OF GOOD QUALITY, FREE FROM DEFECTS AND FAULTS AND IN CONFORMANCE WITH THE CONSTRUCTION DOCUMENTS. ANY AND ALL SUBSTITUTIONS MUST BE PROPERLY APPROVED AND AUTHORIZED IN WRITING BY THE OWNER AND ENGINEER PRIOR TO INSTALLATION.
 -THE CONTRACTOR SHALL FURNISH SATISFACTORY EVIDENCE AS TO THE KIND AND QUANTITY OF THE MATERIALS AND EQUIPMENT BEING SUBSTITUTED AND SHALL ONLY INSTALL SAID SUBSTITUTIONS AFTER APPROVAL BY THE OWNER OR THE OWNER'S ENGINEER.
 -ALL MATERIAL FURNISHED UNDER THIS CONTRACT SHALL BE NEW UNLESS NOTED OTHERWISE. ALL WORK SHALL BE GUARANTEED AGAINST DEFECTS IN MATERIAL AND WORKMANSHIP FOR A PERIOD OF (1) YEAR FOLLOWING SUBSEQUENT COMPLETION OF PROJECT OR AS SPECIFIED. THE CONTRACTOR SHALL REPAIR OR REPLACE AT HIS EXPENSE ALL WORK THAT MAY DEVELOP DEFECTS IN MATERIAL OR WORKMANSHIP WITHIN THE WARRANTY PERIOD.
 -THE GENERAL CONTRACTOR AND EACH SUBCONTRACTOR ARE TO BE RESPONSIBLE FOR VERIFYING EXISTING SITE CONDITIONS AND DIMENSIONS AND THE LOCATION OF BURIED UTILITIES AT THE JOB SITE PRIOR TO THE COMMENCEMENT OF WORK.
 -CONFLICTS AND OMISSIONS WHICH COULD HAVE BEEN DISCOVERED BY FILED VERIFICATION AND INSPECTION, WHETHER INDICATED ON THE CONTRACT DOCUMENT OR NOT, WILL NOT BE ENTERTAINED OR PAID.
- d. MINIMUM BEND RADIUS OF ANTENNA CABLES SHALL BE IN ACCORDANCE WITH CABLE MANUFACTURERS RECOMMENDATIONS.
- e. CABLE ROUTING SHOWN IS DIAGRAMMATIC. ACTUAL ROUTE OF ANTENNA CABLES SHALL BE DETERMINED IN THE FIELD.

3) VERIFICATION

- a. THE CONTRACTOR SHALL VERIFY THAT NO CONFLICTS EXIST BETWEEN THE LOCATIONS OF ANY AND ALL MECHANICAL, ELECTRICAL, PLUMBING, OR STRUCTURAL ELEMENTS, AND THAT ALL REQUIRED CLEARANCES FOR INSTALLATION AND MAINTENANCE ARE MET. NOTIFY THE OWNER OF ANY CONFLICTS, THE OWNER HAS THE RIGHT TO MAKE MINOR MODIFICATIONS IN THE DESIGN OF THE CONTRACT WITHOUT THE CONTRACTOR GETTING ADDITIONAL COMPENSATION.
- b. THE ENGINEER SHALL BE NOTIFIED IN WRITING OF ANY CONDITIONS THAT VARY FROM THOSE SHOWN ON THE PLANS. THE CONTRACTOR'S WORK SHALL NOT VARY FROM THE PLANS WITHOUT THE EXPRESSED APPROVAL OF THE ENGINEER.
- c. THE GENERAL CONTRACTOR SHALL COORDINATE WITH THE LOCAL POWER AND TELEPHONE UTILITIES AND THE CONSTRUCTION MANAGER TO CONFIRM THE SOURCE OF SERVICE PRIOR TO CONDUIT INSTALLATION. THE GENERAL CONTRACTOR SHALL OBTAIN WRITTEN CONFIRMATION OF EXPECTED DATE OF COMPLETION OF THE POWER CONNECTION FROM THE POWER COMPANY.

- d. ACCESS TO PROPOSED WORK SITE MAY BE RESTRICTED. THE CONTRACTOR SHALL COORDINATE INTENDED CONSTRUCTION ACTIVITY, INCLUDING WORK SCHEDULE AND MATERIALS ACCESS, WITH THE RESIDENT LEASING AGENT FOR APPROVAL.
- e. THE ENGINEER HAS NOT CONDUCTED, NOR DOES IT INTEND TO CONDUCT ANY INVESTIGATIONS TO DETERMINE THE PRESENCE OF ANY HAZARDOUS MATERIAL INCLUDING BUT NOT LIMITED TO ASBESTOS, LEAD PAINT, AND PCB'S WITHIN THE CONFINES OF THE PROJECT. THE ENGINEER WILL NOT ACCEPT AND RESPONSIBILITY FOR THE ABATEMENT OR RESULTING CLAIMS FOR DAMAGES OR LOSSES AS A RESULT OF THE PRESENCE OF HAZARDOUS MATERIALS. IF EVIDENCE OF HAZARDOUS MATERIAL IS DISCOVERED, SUSPEND WORK AS REQUIRED BY GOVERNING STATUES, AND NOTIFY THE OWNER. DO NOT PROCEED WITH WORK UNTIL INSTRUCTED BY THE OWNER.

4) CLEAN-UP

- a. THE CONTRACTOR SHALL BE RESPONSIBLE FOR DAILY CLEAN UP OF ALL TRADES AND REMOVE ALL DEBRIS FROM THE CONSTRUCTION SITE. AT THE COMPLETIONS OF THE PROJECT, THE CONTRACTOR SHALL THOROUGHLY CLEAN THE BUILDING, SITE, AND ANY OTHER SURROUNDING AREAS TO A BETTER THAN NEW CONDITION WHILE MEETING THE APPROVAL OF THE OWNER AND THE LANDLORD.

5) SAFETY

- a. THE CONTRACTOR IS RESPONSIBLE FOR ADEQUATELY BRACING AND PROTECTING ALL WORK DURING THE CONSTRUCTION AGAINST DAMAGE, BREAKAGE, COLLAPSE, ETC. ACCORDING TO APPLICABLE CODES, STANDARDS, AND PRACTICES. THIS INCLUDES, BUT IS NOT LIMITED TO THE ADDITION OF TEMPORARY BRACING, GUYS, OR TIE DOWNS THAT MAY BE NECESSARY. SUCH MATERIAL SHALL BE REMOVED AND SHALL REMAIN THE PROPERTY OF THE CONTRACTOR AFTER COMPLETION OF THE PROJECT.
- b. THE CONTRACTOR SHALL BE RESPONSIBLE FOR INITIATING, MAINTAINING, AND SUPERVISING ALL SAFETY PRECAUTION AND PROGRAMS IN CONNECTION WITH THE WORK.
- c. THE CONTRACTOR IS RESPONSIBLE FOR ENSURING THAT THE PROJECT AND RELATED WORK COMPLIES WITH ALL APPLICABLE OSHA, LOCAL, STATE, AND FEDERAL SAFETY CODES AND REGULATIONS GOVERNING THIS WORK.
- d. THE CONTRACTOR WILL BE HELD RESPONSIBLE FOR DAMAGES TO THE EXISTING FACILITY AND INSTALLATION RESULTING FROM CONSTRUCTION AND GENERAL NEGLIGENCE. REPAIR ALL DAMAGES AND RESTORE FACILITY AND INSTALLATIONS TO THE SATISFACTION OF THE OWNER AND THE LANDLORD AT NO EXTRA CHARGE. NOTIFY THE OWNER OF ANY SUCH DAMAGES PROMPTLY AND REPAIR TO 100% SATISFACTION IMMEDIATELY.
- e. CONTRACTOR SHALL BE RESPONSIBLE FOR THE SAFETY OF THE WORK AREA, ADJACENT AREAS AND BUILDING OCCUPANTS THAT ARE LIKELY TO BE AFFECTED BY THE WORK UNDER CONTRACT. WORK SHALL CONFORM TO ALL OSHA REQUIREMENTS.

6) STRUCTURAL STEEL SPECIFICATIONS

- a. THE FABRICATION AND THE ERECTION OF STRUCTURAL STEEL SHALL CONFORM TO THE LATEST AISC SPECIFICATIONS.
- b. UNLESS NOTED OTHERWISE, ALL STRUCTURAL STEEL SHALL MEET THE REQUIREMENTS OF ASTM A36. ALL BOLTS SHALL CONFORM TO THE REQUIREMENTS OF ASTM A325 HIGH STRENGTH BOLTS.
- c. ALL WELDING SHALL BE IN ACCORDANCE WITH THE LATEST AWS STRUCTURAL WELDING CODE. ALL WELDERS SHALL PROVIDE PROPER CERTIFICATION OF QUALIFICATION TO THE LANDLORD OR OWNER PRIOR TO COMMENCING WORK AT THE SITE.
- d. ALL CONNECTIONS NOT FULLY DETAILED ON THESE PLANS SHALL BE DETAILED BY THE STEEL FABRICATOR IN ACCORDANCE WITH AISC SPECIFICATIONS.
- e. HOLED SHALL NOT BE FLAME CUT THROUGH STEEL UNLESS APPROVED BY THE ENGINEER.
- f. WELD SHALL BE MADE WITH E-70XX ELECTRODES UNLESS NOTED OTHERWISE
- g. HOT DIP GALVANIZE ALL ITEMS AFTER FABRICATION WHERE PRACTICAL. GALVANIZING SHALL BE DONE IN ACCORDANCE WITH ASTM A123, A153A, A653A, A653M AND ASTM G90, AS APPLICABLE.
- h. REPAIR DAMAGED SURFACES WITH GALVANIZING REPAIR METHOD AND PAINT CONFORMING TO ASTM A780 OR BY APPLICATION OF STICK OR THICK PASTE MATERIAL SPECIFICALLY DESIGNED FOR REPAIR OF GALVANIZING. CLEAN AREAS TO BE REPAIRED AND REMOVE SLAG FROM WELDS. HEAT SURFACES TO A TEMPERATURE SUFFICIENT TO MELT THE METALLIC IN STICK OR PASTE: SPREAD MOLTEN MATERIAL UNIFORMLY OVER SURFACES TO BE COATED AND WIPE OFF ANY EXCESS MATERIAL.
- i. A NUT LOCKING DEVICE SHALL BE INSTALLED ON ALL PROPOSED AND/OR REPLACE BOLTS.
- j. ALL PROPOSED AND/OR REPLACED BOLTS SHALL BE SUFFICIENT LENGTH TO EXCLUDE THE THREADS FROM THE SHEAR PLANE.
- k. ALL PROPOSED AND/OR REPLACED BOLTS SHALL BE OF SUFFICIENT LENGTH SUCH THAT THE END OF THE BOLT BE AT LEAST FLUSH WITH THE FACE OF THE NUT. A BOLT THAT ENDS BELOW THE FACE OF THE NUT AFTER TIGHTENING WILL NOT BE PERMITTED.

REV.	DATE	DESCRIPTION
A	02/21/14	ISSUED FOR 90% REVIEW
B	02/24/14	REVISED PER COMMENTS

PLANT NO. 2
 1220 PLAINFIELD RD
 DARIEN, IL 60551

GENERAL NOTES

ISSUED FOR:	
REVIEW	-
PERMIT	-
CONSTRUCTION	-
RECORD	-
PROJECT MANAGER	DESIGNER
TS	SEK

JOB NO.
2014708.01



VIEW LOOKING EAST



METRO NS
Darien, IL

THE COLORS SHOWN IN THIS RENDERING ARE CLOSE APPROXIMATIONS, BECAUSE OF INK VARIATIONS AND DIFFERENCES IN PRINTERS, AN EXACT COLOR MATCH CANNOT BE ACHIEVED. THE VIEWER IS ADVISED TO USE THE RENDERING AS A GUIDE FOR THE ARRANGEMENT OF COLORS ON THE BUILDING, AND TO THEN REFER TO THE ACTUAL COLOR OF MATERIAL SAMPLES PROVIDED.





VIEW LOOKING SOUTHWEST

AGENDA MEMO
CITY COUNCIL
MEETING DATE: March 3, 2014

Issue Statement

Medical Cannabis: Consideration of a motion to direct staff to propose City Code amendments, 1. A text amendment to the Zoning Ordinance to list medical cannabis cultivation and dispensing establishments as special uses in the I-1 General Industrial District, and 2. Addressing medical cannabis possession.

Discussion/Overview

The Municipal Services Committee considered this matter at their meeting on February 24, 2014. The Committee recommends the City Council direct staff to draft text amendments to the City Code addressing medical cannabis.

Decision Mode

The Municipal Services Committee considered this item at its meeting on February 24, 2014. The City Council will consider this item at its meeting on March 3, 2014.

Additional Information

Issue Statement

Discussion of proposed City Code amendments, 1. A text amendment to the Zoning Ordinance to list medical cannabis cultivation and dispensing establishments as special uses in the I-1 General Industrial District, and 2. Addressing medical cannabis possession.

General Information

In August 2013, the State of Illinois approved the use of medical cannabis in Illinois beginning January 1, 2014. The law allows local jurisdictions to enact reasonable zoning ordinances regulating locations where cannabis cultivation and dispensing establishments may locate, as long as it is not in conflict with state law. Municipalities may not prohibit medical cannabis cultivation and dispensing establishments.

Per Illinois law:

- **Cultivation establishments** must be located at least 2,500 feet from pre-existing pre-schools, elementary or secondary schools, daycare centers, group daycare centers or an area zoned for residential use.
- **Dispensing establishments** must be located at least 1,000 feet from pre-existing pre-schools, daycare centers or group daycare centers and may not be located in an area zoned for residential use.

Additional Illinois law requirements for dispensing:

- The dispensing organization must be registered by the Department of Finance and Professional

Registration.

- The dispensing organization may only obtain medical cannabis from a registered cultivation center and may only dispense to registered qualified patients.
- The State of Illinois may license up to 60 dispensing organizations in the state which shall be geographically dispersed throughout the state.
- The dispensing organization must be located at least 1,000 feet from pre-existing pre-schools, daycare centers or group daycares.
- The dispensing organization may not be located in an area zoned for residential use.

Staff recommends a text amendment to the Zoning Ordinance adding medical cannabis cultivation and dispensing establishments as special uses within the I-1 General Industrial District. A map is included showing the I-1 zoning district locations within Darien. Special uses require City Council approval via a public hearing before the Planning and Zoning Commission.

Currently, the only properties in Darien zoned I-1 are the Darien Municipal Services Facility at 1041 S. Frontage Road and the property immediately to the east at 1033-35 S. Frontage Road. These properties are the most remote parcels within Darien in terms of nearby schools, daycare centers and residential areas.

The properties noted above are located within 1,000 feet of an area zoned for residential use, area to the north. Therefore, these locations could contain dispensing establishments but not cultivation establishments.

A text amendment to the Zoning Ordinance requires a public hearing before the Planning and Zoning Commission, with the City Council making the final decision.

Staff Findings/Recommendations

Staff recommends the Committee make a recommendation asking the City Council to pursue a text amendment to the Zoning Ordinance addresses medical cannabis establishments as well as amending the City Code to address medical cannabis possession, consistent with Illinois law.

Municipal Services Committee Review – February 24, 2014

The Municipal Services Committee considered this matter at their meeting on February 24, 2014. The following members were present: Alderman Joseph Marchese – Chairman, Alderman Tina Beilke, Alderman Joerg Seifert, Dan Gombac – Director and Elizabeth Lahey – Secretary.

Dan Gombac, Director, reviewed the agenda memo.

The Committee did not have any questions or concerns.

Without further discussion, Alderman Seifert made a motion, seconded by Alderman Beilke, to recommend the City Council direct staff to draft text amendments to the City Code addressing medical cannabis.

Upon a voice vote, THE MOTION CARRIED by a vote of 3-0.

AGENDA MEMO

City Council

March 3, 2014

ISSUE STATEMENT

Resolution confirming City's intent regarding the funding of crossing guard services for School District 61

RESOLUTION

BACKGROUND/HISTORY

During the February 25, 2014, budget meeting the Council discussed District 61 crossing guards. The City had previously informed District 61 that effective April 30, 2014, the city would no longer fund crossing guards for the District. The City Council discussed amending its previous position recognizing that the City's fiscal year ends April 30, 2014, approximately two months prior to the end of the 2013-14 school year. This would result in a two month period without crossing guards during construction of 75th Street. The consensus during the budget meeting was for the City to fund crossing guard services until the end of the 2013-14 school year since School District 61 would not commit to fund the crossing guards for that two month period.

The attached resolution was written to reflect the City Council's consensus to fund the District 61 crossing guards until the end of the 2013-14 school year at which time the City will no longer provide crossing guards for district 61.

STAFF RECOMMENDATION

As directed by the council.

ALTERNATE CONSIDERATION

As directed by the council.

DECISION MODE

This item will be placed on the March 3, 2014, city council agenda for formal consideration.

**RESOLUTION STATING THE POSITION OF THE MAYOR AND CITY COUNCIL
REGARDING THE CITY OF DARIEN'S FUNDING OF CROSSING GUARDS FOR SCHOOL
DISTRICT 61**

WHEREAS, corporate boundaries of the City of Darien contain portions of 3 separate elementary/middle grade school districts including 61,63, and 66; and

WHEREAS the City of Darien currently pays for crossing guards for only one local school district, district 61; and

WHEREAS the city council has previously given advance notice to School District 61 that beginning May 1, 2014, the city will no longer fund crossing guards for District 61; and

WHEREAS, the city council has amended its previous position recognizing that the City's fiscal year ends April 30, 2014, approximately two months prior to the end of the 2013-14 school year creating a two month period without crossing guards during construction of 75th Street; and

WHEREAS, School District 61 would not commit to fund the crossing guards for that two month period;

NOW, THEREFORE, BE IT RESOLVED THAT THE MAYOR AND CITY COUNCIL OF THE CITY OF DARIEN, DUPAGE COUNTY ILLINOIS, as follows:

SECTION ONE, it is the intention of the Darien City Council to fund the District 61 crossing guards until the end of the 2013-14 school year at which time the city will no longer provide crossing guards for district 61

SECTION TWO, the City encourages district 61 to fund their crossing guard program beginning with the 2014-15 school year

SECTION THREE, that the city administrator is directed to forward a certified copy of this resolution upon approval

PASSED BY THE CITY COUNCIL OF THE CITY OF DARIEN, DU PAGE COUNTY, ILLINOIS, this 3rd day of March, 2014.

AYES: _____

NAYS: _____

ABSENT: _____

APPROVED BY THE MAYOR OF THE CITY OF DARIEN, DU PAGE COUNTY,

ILLINOIS, this 3rd day of March, 2014.

KATHLEEN MOESLE WEAVER, MAYOR

ATTEST:

JOANNE E. RAGONA, CITY CLERK

APPROVED AS TO FORM:

CITY ATTORNEY

AGENDA MEMO
City Council
March 3, 2014

ISSUE STATEMENT

An ordinance amending Title 8 of the Darien City Code to add a Chapter 23 “Crime Free Residential Housing Requirements.”

ORDINANCE

BACKGROUND/HISTORY

Over the past three years the Darien Police Department has increased their utilization of statistics to deploy police officers, track calls for service, and identify crime patterns. In the summer of 2013 statistics showed a large increase in the calls for service to multifamily units in the community. The Command Staff met with many property managers to discuss ways to help landlords proactively implement methods that assist landlords to reduce and control criminal activity in rental units. Many municipalities have Crime Free Residential Housing ordinances that include training and educating landlords and require several best practices. The components and benefits of this specific ordinance include:

- **Requiring a “Crime Free Lease Addendum,” signed by tenants along with a lease, in which a tenant agrees not to engage in criminal activity.** If a tenant engages in criminal activity, a landlord could claim the entire lease has been violated.
- **Creating an obligation for the landlord not to permit criminal activity in their rental units.**
- **Requiring landlords to attend a Crime Free Housing Seminar.** The landlord will be required to complete an educational seminar hosted by the police department to ensure they are properly trained on best practices.
- **Requiring a license from the City of Darien.** The City of Darien will be provided contact and emergency information from landlords to assist with communication and data collection.

This ordinance anticipates these requirements be met by May 1, 2014. The police department will train a patrol officer to conduct the seminars and will monitor criminal activity within the multi-family housing. The Clerk’s Office will be responsible for issuing the licenses, in a similar fashion as business licenses.

STAFF/COMMITTEE RECOMMENDATION

The Police Committee recommended approval of the ordinance 2-1.

ALTERNATE CONSIDERATION

Not approving the ordinance would be an alternate consideration.

CITY OF DARIEN
DU PAGE COUNTY, ILLINOIS

ORDINANCE NO. _____

**AN ORDINANCE AMENDING TITLE 8 OF THE DARIEN CITY CODE
TO ADD A CHAPTER 23, "CRIME-FREE RESIDENTIAL
HOUSING REQUIREMENTS"**

**ADOPTED BY THE
MAYOR AND CITY COUNCIL
OF THE
CITY OF DARIEN**

THIS 3rd DAY OF MARCH, 2014

**Published in pamphlet form by authority of the
Mayor and City Council of the City of Darien,
DuPage County, Illinois, this _____ day of
March, 2014.**

**AN ORDINANCE AMENDING TITLE 8 OF THE DARIEN CITY CODE
TO ADD A CHAPTER 23, "CRIME-FREE RESIDENTIAL
HOUSING REQUIREMENTS"**

WHEREAS, the Mayor and City Council have determined that various forms of criminal activity or other similar activity detrimental to the public, health, safety, and welfare is more likely to take place

in rental dwellings than in owner-occupied residential dwellings, because the residents of rental dwellings are not property taxpayers of the City, do not necessarily intend to remain residents of the City for a long period of time, and otherwise are not invested in the City; and

WHEREAS, owners of residential rental dwellings are either non-residents, corporations, or other entities with no personal physical presence in the City; and

WHEREAS, landlords have the ability to utilize the terms of a lease to prevent the occupancy of residential rental units by individuals who engage in criminal activity or allow criminal activity to take place in and about the rental unit; and

WHEREAS, the Mayor and City Council have determined that an effective way to prevent and abate potential nuisances relating to criminal activity taking place within residential rental property units is to require owners of rental property to include a “Crime-Free Lease Addendum” into the lease;

WHEREAS, it is the purpose of this Ordinance to define nuisances which exist or may exist as a result of tenants or others associated with certain residential rental properties engaging in or allowing others to engage in various forms of criminal activity; and

WHEREAS, it is not the purpose of this Ordinance to require a landlord to initiate eviction proceedings or otherwise terminate the lease of a tenant who himself or herself is a victim of a crime committed in or about a rental unit;

NOW, THEREFORE, BE IT ORDAINED BY THE CITY COUNCIL OF THE CITY OF DARIEN, DU PAGE COUNTY, ILLINOIS, IN THE EXERCISE OF ITS HOME RULE POWERS, as follows:

SECTION 1: Declaration of Nuisance; Declaration of Purpose.

A. The Mayor and City Council of the City of Darien hereby find, declare, and define that, subject to the limitations set forth in this Ordinance, it is a nuisance, detrimental to the public health, safety, and welfare for a tenant of a “Covered Residential Rental Unit,” as defined hereinbelow, or occupant of such unit, a guest in such unit, or any other party under the control of the tenant or occupant of such unit to engage in, facilitate, or conspire to engage in, any activity which violates the criminal laws of the State of Illinois or any provisions of the Darien City Code.

B. The Mayor and City Council further find and declare that a reasonable way to abate such

nuisances is by requiring owners of Covered Residential Rental Units to include a Crime-Free Lease Addendum to all leases for such residential properties.

SECTION 2: New Chapter. Title 8 of the Darien City Code, “Police Regulations,” is hereby amended by adding the following Chapter 23, “Crime-Free Lease Addendum” as follows:

Chapter 23
CRIME-FREE RESIDENTIAL HOUSING REQUIREMENTS

8-23-1: DEFINITIONS:

For purposes of this chapter, the following words, terms and phrases, when used herein, shall have the meanings ascribed to them in this section, except where the context clearly indicates a different meaning:

COVERED RESIDENTIAL RENTAL UNIT: Shall mean any rented residential unit in a multi-family building consisting of ten (10) or more dwelling units. Regardless of whether the building is an apartment building or in a building under condominium or similar ownership which allows individual units to be rented by the owner thereof or by a management entity.

CRIME-FREE LEASE ADDENDUM: Shall mean a provision which makes it a violation of the lease for a tenant, occupant of the premises, a guest of the tenant or occupant of the premises, or any other party under the control of the tenant or occupant of the premises with the permission or consent of the tenant or an occupant of the premises to engage in, facilitate, or conspire to commit criminal activity while on the leased premises. A Crime-Free Lease Addendum shall provide the landlord with the authority to evict the tenant in accordance with the Illinois Forcible Entry and Detainer Statute, 735 ILCS 5/9-101, *et seq.*, if it is established by a preponderance of the evidence that a violation of the Crime-Free Lease Addendum has occurred.

LANDLORD: Shall mean an owner, administrator, manager, or person in control of the operation of a Covered Residential Rental Unit.

TENANT: Shall mean any individual who is a signed lessee of a Covered Residential Rental Unit.

8-23-2: CRIME-FREE LEASE ADDENDUM REQUIRED:

(A) Every written lease or other agreement for rental of any Covered Residential Rental Unit shall contain a Crime-Free Lease Addendum or have a clause in the lease similar to a Crime-Free Lease Addendum. The Office of the City Administrator shall provide at no cost samples of a Crime-Free Lease Addendum and shall review any clauses within actual leases with the City Attorney to determine if the clause is consistent with the Crime-Free Lease Addendum contained herein.

(B) A lease which contains the “(Prototype) Crime-Free Lease Addendum” set forth hereinbelow shall be deemed to be in full compliance with the requirements of this section:

“Crime-Free Lease Addendum

For the rental unit located at:

In consideration of the execution or renewal of a lease of the dwelling unit identified in the lease, Owner (or Owner's agent or representative) and Tenant agree as follows:

1. Neither the Tenant, any member of the Tenant's household, any guest or any other person associated with the Tenant on or near the leased premises:
 - A. shall engage in criminal activity at or near the leased premises.
 - B. shall engage in any act at or near the leased premises intended to facilitate criminal activity.
 - C. shall permit the rental dwelling unit to be used for or to facilitate any criminal activity.
 - D. shall engage in any act intended to facilitate any violation of City ordinances or codes or any other violation as defined by local, state or federal law.
 - E. shall engage in any act intended to obstruct or resist law enforcement efforts against criminal activity at or near the rental unit or common areas.
 - F. shall permit the rental unit to be used for or to facilitate any violation of state, federal or local law.
2. VIOLATION OF ANY OF THE ABOVE PROVISIONS SHALL BE A MATERIAL, AND IRREPARABLE VIOLATION OF THE LEASE AND GOOD CAUSE FOR TERMINATION OF THE TENANCY. A single violation of any provision of this added Addendum shall be deemed a serious violation and material non-compliance with the lease. Any violation of the above provisions will still be considered a violation regardless of whether or not the Tenant could not control the behavior of other occupants of the unit, could not foresee, or did not have knowledge of the violation. It is understood and agreed that a single violation shall be good cause for IMMEDIATE termination of the lease under the Illinois Compiled Statutes. Unless otherwise provided by law, proof of violation shall not require criminal conviction, BUT SHALL BE BY PREPONDERANCE OF THE EVIDENCE. Preponderance of the evidence can be determined by but not limited to a police report, police citations, information received from the police department or a police officer, or any observations made by the landlord or his agent.
3. Tenant consents to venue in the Eighteenth Judicial Circuit in DuPage County, Illinois, in the event Owner initiates legal action against the Tenant.
4. Tenant agrees that service of process of any legal proceeding, including but not limited to, a special detainer or forcible detainer action, or service of any notice to Tenant, shall be effective and sufficient of purpose of providing legal service and conferring personal jurisdiction upon any Illinois court as to any Tenant, co-signer, occupant or guarantor, if waived upon any occupant or other person of suitable age

and discretion who is present at the premises and residing therein, notwithstanding the fact that a Tenant, co-signer, occupant or guarantor may reside at a different location other than the property address described in the lease agreement. This agreement regarding service is in addition to, and not in lieu of, any manner of service authorized under Illinois law or rule. By signing this lease, the undersigned hereby waives any objection to service carried out under the terms of this agreement. This provision shall be effective for any extension, renewal or modification of the Initial Lease.”

- (D) In the event the Landlord initiates eviction proceedings based on the Tenant’s violation of the Crime-Free Lease Addendum, the City will, at no charge to the Landlord and without the necessity for subpoena, cooperate by arranging for City staff who have relevant information, to testify at any such legal proceeding.
- (E) Nothing in this Section shall require or authorize a Landlord to enforce the Crime-Free Lease Addendum against a Tenant as a result of any activity which might otherwise be a violation of the Crime-Free Lease Addendum when the Tenant himself or herself is the victim of criminal activity.

8-23-3: EXISTING MONTH-TO-MONTH TENANCIES; FUTURE ORAL LEASES:

- (A) The Landlord of every Covered Residential Rental Unit for which no written lease agreement exists (tenancy at will) including, but not limited to, a month-to-month oral leasehold as of the effective date of this Ordinance shall require the tenant at will to enter into a Crime-Free Lease Addendum in writing within ninety (90) days of the effective date of this Ordinance.
- (B) The Landlord of every Covered Residential Rental Unit who enters into an oral lease agreement more than ninety (90) days after the date of this Ordinance shall require the Tenant to execute a Crime-Free Lease Addendum.

8-23-4: NUISANCE RESIDENTIAL RENTAL PROPERTY VIOLATIONS BY TENANTS:

It is hereby declared a public nuisance and a danger to the public safety, health, welfare and morals of the City and its residents for any tenant of residential property to:

- (A) knowingly allow any of the following offenses to occur on the premises being rented or leased by the tenant: murder, kidnapping, aggravated kidnapping, prostitution, solicitation of prostitution, pandering, obscenity, child pornography, harmful materials, sale of obscene publications, criminal housing management, possession of explosives, unlawful use of weapons, sale of firearms, gambling, keeping a gambling place, concealing a fugitive, violation of the Illinois Controlled Substances Act, violation of the Cannabis Control Act, or commission of any two or more offenses by imprisonment for a period of more than six (6) months under the laws of the State of Illinois or the United States.
- (B) knowingly allow any of the following offenses to occur on the premises being rented by the tenant: commission of three (3) or more City ordinance violations in a twelve (12) month period or an unreasonably high number of calls for police service including, but not limited to, calls that may fall within the descriptions listed in subsection (a) of this Section that when compared to other properties in the City of Darien of similar type, reasonably indicates that activity on the rented premises is adversely affecting the health, safety, welfare or morals of other persons

residing in the area.

8-23-5: VIOLATION OF CRIME-FREE LEASE ADDENDUM BY LANDLORD; PRE-ENFORCEMENT DUE PROCESS; ADDITIONAL LIMITATION:

- (A) It shall be unlawful for any Landlord to permit any tenant to occupy any Covered Residential Rental Unit in violation of any provisions of the Crime-Free Lease Addendum required by this chapter.
- (B) In the event the City brings an action based on nuisance Covered Residential Rental Unit property violations by a Tenant, the City shall not join the Landlord as a party unless required by Court order.
- (C) No enforcement action shall be filed against a Landlord unless the City first notifies the Landlord of the claimed violation and offers the Landlord an opportunity to meet with City representatives in order to determine whether the claimed violation may be resolved short of a judicial enforcement proceeding. Absent an emergency, such pre-enforcement notice and opportunity to be heard will be given to the Landlord at least twenty-one (21) days prior to the initiation of any enforcement action.

8-23-6: LICENSE REQUIRED:

No individual or entity shall engage in the business of renting Covered Residential Rental Units to the public unless a valid and current Residential Rental License has been issued by the City Clerk for the specific location.

8-23-7: APPLICATION FOR LICENSE:

Application for Residential Rental License shall be made in the name of the legal owner of the premises to be rented and submitted to the City Clerk on forms provided by the City. The Application shall identify the location of the premises, the name, address and telephone number of the owner, the name, address and telephone number of the manager of the premises, the owner's agent for service of process and such other information as the City may reasonably require on the Application form.

8-23-8: LICENSE FEE:

The annual fee for a Residential Rental License shall be paid at the time of application in an amount equal to \$10 per rental unit.

8-23-9: TERM OF LICENSE; TRANSFER PROHIBITED; RENEWAL:

A Residential Rental License shall be issued for a period of one (1) calendar year and shall expire on April 30th of the year of issuance. Such Licenses are not transferable. Each new owner of a building that contains a Covered Residential Rental Unit must obtain a License. Application for renewal shall be made in the same manner as for a new License. No License shall be issued or renewed until payment in full of all license and inspection fees has been made.

8-23-10: CRIME-FREE HOUSING SEMINAR REQUIRED:

All persons applying for a Residential Rental License and all persons administering, managing, or controlling the operation of any Covered Residential Rental Unit must attend a Crime-Free, Multi-Housing Seminar administered by the City's Police Department prior to issuance of the License. Each Licensee shall attend the Seminar every three (3) years. In the event a new owner acquires the rental dwelling for which a License has been issued and/or a new manager is hired, the new owner and/or manager shall have three (3) months after acquisition or hire to attend the Seminar. The City shall issue a written notice to every person or entity subject to this training requirement advising as of the obligation. If the training requirements are not satisfied within three (3) months from the date of the Notice, said person or entity shall be subject to a fine of up to fifty (\$50) dollars per day. Each day shall be considered a separate violation.

8-23-11: ENFORCEMENT:

Subject to the approval of the City Council, the City Administrator or his designee may seek appropriate injunctive relief to prevent continuing violation of this Chapter. The City Administrator or his designee shall have the duty to enforce the provisions of this Chapter.

8-23-12: PENALTY:

Whoever violates, fails to comply with or resists the enforcement of any of the provisions of this chapter shall be subject to citation and a fine of not less than Two Hundred Fifty & 00/100 (\$250.00) Dollars nor more than Seven Hundred Fifty & 00/100 (\$750.00) Dollars. A separate offense shall be deemed committed each day a violation exists.

SECTION 3: HOME RULE AUTHORITY. This ordinance and each of its terms shall be the effective legislative act of a home rule municipality without regard to whether such ordinance should (a) contain terms contrary to the provisions of current or subsequent non-preemptive state law, or (b) legislate in a manner or regarding a matter not delegated to municipalities by state law. It is the intent of the corporate authorities of the City of Darien that to the extent that the terms of this ordinance should be inconsistent with any non-preemptive state law, that this ordinance shall supersede state law in that regard within its jurisdiction.

SECTION 4: EFFECTIVE DATE. This Ordinance shall be in full force and effect from and after its passage and approval, and shall subsequently be published in pamphlet form as provided by law. The requirements of Section 8-23-2 shall apply to all written leases entered into with an effective date of September 1, 2014, or thereafter.

PASSED BY THE CITY COUNCIL OF THE CITY OF DARIEN, DU PAGE COUNTY, ILLINOIS, this 3rd day of March, 2014.

AYES: _____

NAYS: _____

ABSENT: _____

APPROVED BY THE MAYOR OF THE CITY OF DARIEN, DU PAGE COUNTY,

ILLINOIS, this 3rd day of March, 2014.

KATHLEEN MOESLE WEAVER, MAYOR

ATTEST:

JOANNE E. RAGONA, CITY CLERK

APPROVED AS TO FORM:

CITY ATTORNEY