

AGENDA
Municipal Services Committee
April 27, 2015
6:30 P.M. – Council Chambers

1. **Call to Order & Roll Call**
2. **Establishment of Quorum**
3. **New Business**
 - a. **Carriage Greens Country Club, 8700 Carriage Green Drive:** Petitioner seeks an amendment to the special use approving the Carriage Green Country Club, Ordinance O-31-72, in order to construct a practice facility, including two teeing areas and practice greens
 - b. **Neighborhood Parking Issues/Hinsdale South High School:** Discussion regarding overflow Hinsdale South High School special event parking on Poplar Lane, Eleanor Place and Elm Street
 - c. **Ordinance – Authorizing the Sale of Personal Property Owned by the City of Darien**
 - d. **Resolution – To Enter into a Contract Agreement with Morton Salt for the Purchase of Rock Salt in an Amount not to Exceed \$239,707.32**
 - e. **Resolution – Authorizing the Mayor to Execute an Intergovernmental Agreement with the Darien Park District for the Reimbursement of Rock Salt through the City’s 2015/16 Rock Salt Agreement**
 - f. **Resolution – Authorizing the Mayor to Execute an Intergovernmental Agreement with Center Cass School District #66 for the Reimbursement of Rock Salt through the City’s 2015/16 Rock Salt Agreement**
 - g. **Resolution – Authorizing the Mayor to Execute a Contract for the 2015 Landscape Fertilization Program between the City of Darien and Tru Green, LP in an Amount not to Exceed \$21,836.09**
 - h. **Ordinance – Ascertaining the Prevailing Rate of Wages for Laborers, Workmen, and Mechanics Employed on Public Works Projects for the City of Darien, County of DuPage, Illinois**
 - i. **Resolution – Purchase of One (1) New 2015 Ford Expedition Carryall Unit from Landmark Ford in the Amount of \$29,941.00**

- j. Resolution - Purchase of One (1) New 2015 Ford F-150 Crew Cab 2WD Pick-up Truck from Roesch Ford in the Amount of \$22,301.00**
 - k. Resolution – To Enter into an Agreement with Christopher B. Burke Engineering, Ltd. for Professional Services Related to the Carlisle Court Bridge Repairs in an Amount not to Exceed \$18,800.00**
 - l. Resolution – Accepting a Proposal from K&K Well Drilling in the Amount of \$54,800.00 for Abandonment of Wells No. 2, 5 and 7**
 - m. Resolution – Illinois Department of Transportation authorizing the expenditure of Motor Fuel Tax Funds**
 - n. Resolution – Authorizing the Mayor to execute an Intergovernmental Agreement with the County of DuPage for the purpose of sharing costs for design and construction engineering, IDOT Letting and Construction for the Street Lighting Project within limited locations of the 75th Street Corridor and the Cass Avenue Corridor in an amount not to exceed \$278,003.10**
 - o. Minutes – March 23, 2015 Municipal Services Committee**
- 4. Director’s Report**
 - 5. Next scheduled meeting – Tuesday, May 26, 2015**
 - 6. Adjournment**

AGENDA MEMO
MUNICIPAL SERVICES COMMITTEE
MEETING DATE: April 27, 2015

Issue Statement

PZC 2015-02:

Carriage Green Country Club, 8700 Carriage Greens Drive: Petitioner seeks an amendment to the special use approving the Carriage Green Country Club, Ordinance O-31-72, in order to construct a practice facility, including two teeing area and practice greens.

General Information

Petitioner/Owner:

Carriage Green Country Club
8700 Carriage Greens Drive
Darien, IL 60561

Property Location:

8700 Carriage Greens Drive

PINs:

09-33-301-012, 10-04-101-012

Existing Zoning:

R-3 Multi-Family Residence

Existing Land Use:

Golf course, country club

Comprehensive Plan Update:

Parks/Open Space

Surrounding Zoning and Land Use:

North: R-3 Multi-Family Residence – golf course, single-family detached homes

East: R-3 Multi-Family Residence – golf course, single-family detached homes

South: R-3 Multi-Family Residence – golf course, single-family detached homes

West: R-2 Single-Family Residence – single-family detached homes

Size of Property:

110 acres (golf course)

Floodplain:

Portions of the golf course are located within a floodplain, but not the area proposed for the practice facility.

Natural Features:

Floodplain and wetlands. The proposed practice facility is located within a wetland/wetland buffer.

Transportation:

Access from Carriage Greens Drive.

History:

In 1972, the property was annexed into Darien and the City Council approved a special use for the golf course as well as the residential areas of the Carriage Green golf course development.

Documents Submitted

This report is based on the following information submitted to the Community Development Department by the Petitioner:

1. Site Plan and netting detail, 3 sheets, prepared by Wight & Co., dated February 23, 2015.

Planning Overview/Discussion

The subject property is located north of N. Frontage Road and west of Bailey Road. The Carriage Green Country Club development includes the golf course as well as adjacent single-family and townhomes.

The petitioner seeks to construct a practice facility to include two teeing areas and practice greens. The practice facility is to be located adjacent to the ponds to the west and northwest of the club house. The plan includes netting along both sides of both teeing areas.

The south pond contains wetlands. The proposed practice facility is located within the wetland and 50-foot wetland buffer area surrounding the wetland. DuPage County must certify the plan complies with the Countywide Stormwater and Floodplain Ordinance before the City can issue a permit. The City Engineer will review the grading plan to ensure compliance with stormwater management.

The special use request must address the following criteria for approval:

1. That the special use is deemed necessary for the public convenience at the location specified.
2. That the establishment, maintenance, or operation of the special use will not be detrimental to, or endanger the public health, safety, or general welfare.
3. That the special use will not be injurious to the use and enjoyment of other property in the immediate vicinity for the purposes already permitted, nor substantially diminish and impair property values within the neighborhood.
4. That the establishment of the special use will not impede the normal and orderly development and improvement of the surrounding property for uses permitted in the district.
5. That the exterior architectural design, landscape treatment, and functional plan of any proposed structure will not be a variation with either the exterior architectural design, landscape treatment, and functional plan of the structures already constructed or in the course of construction in the immediate neighborhood or the character of the applicable district, as to cause a substantial depreciation in the property values within the neighborhood.
6. That adequate utilities, access roads, drainage, and/or necessary facilities have been or are being provided.
7. That adequate measures have been or will be taken to provide ingress and egress so designed as to minimize traffic congestion in the public streets.
8. That the special use shall, in all other respects, conform to the applicable regulations of the district in which it is located, except as such regulations may, in each instance, be modified by the City Council pursuant to the recommendations of the planning and

Zoning Commission and the Planning and Development Committee.

Staff Findings/Recommendations

Staff does not object to the proposed plan. The proposed practice facility is consistent with the existing golf course use. The proposed facility will not impede the normal and orderly development and improvement of the surrounding property for uses permitted in the district, the proposed facility will not create traffic congestion in nearby public streets.

Therefore, staff recommends the Planning and Zoning Commission make a recommendation approving the special use amendment:

Based upon the submitted petition and the information presented, the request associated with PZC 2015-02 is in conformance with the standards of the Darien City Code and, therefore, I move the Planning and Zoning Commission recommend approval of the petition subject to the following:

- 1. DuPage County to review and certify plans and in compliance with the Countywide Stormwater and Floodplain Ordinance related to wetlands**
- 2. City Engineer to review grading plan for stormwater management compliance.**

Planning and Zoning Review – March 4, 2015

The Planning and Zoning Commission considered this matter at its meeting on March 4, 2015. The following members were present: Beverly Meyer – Chairperson, Ronald Kiefer, John Laratta, John Lind, Louis Mallers, Raymond Mielkus, Pauline Oberland, Kenneth Ritzert, Michael Griffith – Senior Planner and Elizabeth Lahey – Secretary.

Absent: Susan Vonder Heide.

Michael Griffith, Senior Planner, reviewed the staff agenda memo, noted the project location and indicated that plans will need to be reviewed for stormwater management and wetland impacts. He stated the County will review wetland impacts.

Bob Bergdoll, Director, Carriage Greens Country Club, described the proposed practice facility. He stated he is working to improve the golf course, to bring in new people and groups. He stated the practice facility will attract lessons, training activities, including high school and college teams. He stated the north practice area will be for training while the south practice area will be for warming up. Mr. Bergdoll stated the plan includes netting which will be taken down during the off season.

Mr. Bergdoll stated the goal is to increase revenue which in turn increases the use/entertainment tax collected by the City.

Commissioner Oberland asked about the 18th hole location and if during mild winters there could be year round golf.

Mr. Bergdoll stated the 18th hole remains, he stated the netting will be up when the golf season opens.

Chairperson Meyer asked about lighting.

Mr. Bergdoll stated there will not be lighting.

Commissioner Kiefer asked about impacts to the wetlands, drainage by the netting and netting details.

Mr. Bergdoll stated the netting will not impact wetlands or drainage. He stated the footing for the netting will be about 8.5 feet deep, bottom of the nets about 3 feet above the ground, he provided a sample of the net.

Commissioner Laratta asked if areas to the west flood, stated his concern with impacts to the wetlands.

Mr. Bergdoll stated he is not aware of flooding to the west.

Dale Schaffer, Creekside Lane, stated he lives next to the golf course, provided photos showing trees on course property coming down, flooding. He stated his property value will decrease and doesn't want the netting.

Frank Noverini, Creekside Lane, stated he lives next to the golf course, questioned why the engineering hasn't been done yet, stated more balls will be coming onto his property, stated the practice areas are too close to his house, will decrease his property value.

Kelly Gilsan, Lakeridge Drive. She stated the proposed changes to the golf course are appropriate, she stated the best use of the property is for a golf course. She stated the golf course helps the City's tax base.

Don Carkhuff, Creekside Lane, stated netting will destroy his view, it will be an eyesore.

Steve Knorps, Creekside Lane, stated a 40-foot tall net will decrease his property value and will not help with safety. He stated the golf course floods, his basement floods.

Byron Wyncs, Wight & Co., stated the wetlands are not being disturbed. He stated the plan includes minor reshaping of the ground with minimal fill. He stated the area is turf now and will remain turf. He stated stormwater will drain to the existing ponds. He stated engineering plans will be submitted to the City and County.

There was a question on whether the ground will support the netting given comments the ground is wet. Mr. Wyncs stated the pole footing will have to be determined based on soil conditions.

Commissioner Laratta asked about mitigating flooding to the west. He asked if there are other options other than nets, or net color.

Mr. Wynn stated the plan includes only minor re-grading. He stated the black netting is the best option as it “disappears” and is light weight.

Frank Kalisik, Royal Oak, stated he wants the golf course to stay but doesn’t want the netting. He stated the nets will be ugly, will fall apart.

Terria Knorps, stated she is a realtor, stated her concern about property values.

Mr. Bergdoll stated the netting is 90% air. He stated the practice facility will increase the value of the golf course which will increase adjacent property values. He stated practice facilities are needed to attract golf teams.

Commissioner Oberland asked if landscaping is possible on the house side of the netting, such as tall trees. She stated the golf course should remain because the property could be sold to a developer and homes put up.

Commissioner Mallers stated he would like engineering addressed before a decision is made, including the County’s review of the wetlands.

Commissioners Lind and Kiefer agreed. Commissioner Laratta stated additional information is needed.

Commissioner Ritzert asked if a different ball could be used and to eliminate the netting.

Mr. Bergdoll stated there is a lighter ball but it would have the same velocity.

Without further discussion, Commissioner Mallers made a motion to continue the matter in order for the petitioner to address the following items, seconded by Commissioner Laratta:

- 1. Engineering, including wetland impacts.**
- 2. Landscape plan to screen the netting.**
- 3. Address resident concerns.**

**Upon a roll call vote, THE MOTION CARRIED by a vote of 8-0.
Commissioner Vonder Heide was absent.**

Mr. Griffith stated a new public hearing notice will be sent out.

Planning and Zoning Commission – April 15, 2015

The petitioner submitted engineering plans for review. The City Engineer has reviewed the plans and issued review comments, dated March 27, 2015, attached. The petitioner has submitted revised plans for the City Engineer to review. County comments are still needed.

Both wetland and stormwater management issues are to be substantially addressed prior to the

April 15, 2015, meeting. If this does not occur, the meeting will be canceled and placed on the May 6, 2015, agenda.

The petitioner is to have a professional at the meeting to discuss the safety of balls hitting nearby homes.

The plans have been revised eliminating the netting.

Planning and Zoning Commission Review – April 15, 2015

The Planning and Zoning Commission considered this matter at its meeting on April 15, 2015. The following members were present: Beverly Meyer – Chairperson, Ronald Kiefer, John Laratta, John Lind, Louis Mallers, Pauline Oberland, Kenneth Ritzert, Susan Vonder Heide, Michael Griffith – Senior Planner and Elizabeth Lahey – Secretary.

Absent: Raymond Mielkus.

Michael Griffith, Senior Planner, noted the plan had been changed eliminating the netting. He stated the City Engineer has approved the plan concerning stormwater management and that the petitioner has submitted plans to the County concerning wetland impacts.

Dan Gombac, Director, confirmed that DuPage County has to certify the plans comply with wetland impacts before a permit can be issued.

Bob Bergdoll, CEO, Carriage Greens Country Club, stated they have eliminated netting from the plan. He stated there will be an attendant to coordinate between players and training activities. He stated they will use floating balls so they can be retrieved from the water.

Commissioner Mallers asked if trees will be planted to help deflect balls.

Mr. Gombac stated he has met with residents and Carriage Greens to discuss balls, property damage and replacing removed trees.

Neil Christianson, Creekside Lane, stated he paid a premium to live on the golf course. He stated he is concerned with the current condition of the golf course, supports the plan to improve it, accepts the risks of living on the golf course with balls damaging property.

Gina Madding, attorney, representing Frank and Diane Noverini, Creekside Lane, asked if a safety study has been done, asked how the City will address safety.

Ken Abraham, attorney, representing Carriage Greens Country Club, stated the goal is to decrease the number of golf outings and increase the number of serious golfers using the course. He stated he is not aware of safety studies for this type of use. He stated they have a golf expert to address safety and ball hitting.

John Perma, Naperville, golf pro at Oakbrook, stated he teaches golf and played professional golf. He stated most golfers hit right-handed. He stated the ball would have to be hit then

change direction by 90 degrees to hit a home on Creekside from the teeing area.

Heather Ramirez, Heather Lane, stated she is favor of the plan to improve the golf course.

Dale Schafer, Creekside Lane, stated he was concerned with driving range. He stated he would like a 1-year review if approved. He stated the plan is much improved without lighting and netting, would like to see trees planted.

Commissioner Kiefer stated he liked the idea of a review to be put into place.

Commissioners Laratta, Lind, Oberland and Chairperson Meyer stated they were not in favor of requiring a review.

Mr. Griffith stated an email was received from Peter Stukas, Royal Oak Road, stating his support for the planned improvements, copy provided to the Commissioners.

Without further discussion, Commissioner Laratta made the following motion, seconded by Commissioner Oberland:

Based upon the submitted petition and the information presented, the request associated with PZC 2015-02 is in conformance with the standards of the Darien City Code and, therefore, I move the Planning and Zoning Commission recommend approval of the petition subject to the following:

- 1. DuPage County to review and certify plans and in compliance with the Countywide Stormwater and Floodplain Ordinance related to wetlands.**

**Upon a roll call vote, THE MOTION CARRIED by a vote of 8-0.
(Commissioner Mielkus was absent.)**

Municipal Services Committee – April 27, 2015

In a letter dated April 13, 2015, from Dan Lynch, PE, Christopher B. Burke Engineering, City Engineer, the plans relating to stormwater management are approved, subject to DuPage County certifying the plan complies with wetland and floodplain regulations.

Correspondence from residents received attached to this memo.

Staff has been working with Carriage Greens to address light intensity and glare onto adjacent properties from the parking lot lighting. Staff would like to add bringing this into compliance as a condition of approval.

Based on the Planning and Zoning Commission's recommendation, staff recommends the Committee make the following recommendation:

Based upon the submitted petition and the information presented, the request associated with PZC 2015-02 is in conformance with the standards of the Darien

City Code and, therefore, I move the Municipal Services Committee recommend approval of the petition subject to the following:

- 1. DuPage County to certify plans are in compliance with the Countywide Stormwater and Floodplain Ordinance related to wetlands.**
- 2. Parking lot lighting to be brought into compliance related to light intensity and glare onto adjacent properties.**

Decision Mode

Planning and Zoning Commission: March 4, 2015

Planning and Zoning Commission: April 15, 2015

Municipal Services Committee: April 27, 2015



CHRISTOPHER B. BURKE ENGINEERING, LTD.

9575 West Higgins Road Suite 600 Rosemont, Illinois 60018 TEL (847) 823-0500 FAX (847) 823-0520

April 13, 2015

City of Darien
1702 Plainfield Road
Darien, IL 60561

Attention: Mike Griffith

Subject Carriage Greens Club – Practice Facility
(CBBEL Project No. 95-323H182)

Dear Mike:

As requested, we have reviewed the revised site improvement plans for the aforementioned property prepared by Wright & Company and dated March 30, 2015 and stormwater submittal prepared by Wight & Company dated March 31, 2015. In our opinion, the plans and supporting documents are now in general compliance with City Code and standard engineering methods subject to the following:

1. Certification of the submittal by DuPage County is required with respect to wetlands and floodplain.

If you have any questions or concerns, please do not hesitate to contact me.

Sincerely,

A handwritten signature in blue ink, appearing to read 'Daniel L. Lynch'.

Daniel L. Lynch, PE, CFM
Head, Municipal Engineering Department

Re: Carriage Greens Special Use Amendment: PZC 2015-02 Ordinance 0-32-71
Input to the March 4 Planning and Zoning Commission considering same

Submitted by:
Dale Schafer
Creekside Lane

Picture #1: Our backyard view to the northeast



Picture #2: Looking from our back yard to the east Trees coming down.



Picture 3: Looking east of our back yard with proposed driving range tee area; from the volley ball court to the creek.



Now imagine the 30-40' safety netting depicted in packet on side of creek on all prior pictures and golfers teeing off in tee box to right. Thank goodness, lighting has been dropped from this recent proposal!
Realtors informal reaction re: proposed plan: You have to be kidding? (Reference points 3 & 5 on page 2 of the Commission packet "Special use request must address the following criteria for approval:")

Picture 4: Dredging of the creek of all its vegetation has taken care of the wildlife i.e. ducks, cranes and herons.



Picture #5: From the south tee area looking between the willows on the peninsula driving range



Picture 5: Proposed driving range between the willows. Yes it floods!



The area is a floodplain and a wetland. Three times last year it rained enough over night where one could take a row boat from the stone flower box in my yard (picture #1) and row across and over the eighteenth green to where the white building is depicted on picture #2. Unfortunately one can't take a picture of same at night, but this was taken at about noon as the area continued to work at draining.

Picture 7: At north end of pond along the Bog area adjacent to 155 ft mark on your map looking east to the Chip and Pitch Area. This area is always soaked and retains its water as a drainage area from the north, If this is filled in, how will that affect the floodplain, wetland area?



What happens if and when? (Particularly as a Murphy's law person stating *whatever can go wrong, will* given my past decade plus of living on the golf course.)

Picture 8: Will the fencing supports, given the soil condition of a floodplain/wetland along the creek bank and elsewhere, need to later be supported as in the lower left of this picture should the floodplain/wetland soil over time not support the weight of the posts? *My own house reflects the problems that can occur given the area soil conditions.*

Will additional or higher fencing be needed later as time goes on given the two way driving practice play proposed.



Informing course residents of the proposal

- * Mr. Dombac's follow-up email to course CEO of Mon., Sept. 22, 2014 confirming residents would be invited to an upcoming meeting regarding the concept.
- * Carriage Greens mails copy of City of Darien's Notice of Public Hearing to residents as put together by JoAnne Ragona as published in newspaper – received Feb. 13, 2015. No other clarification or notice of a meeting to inform residents of proposal going before Commission enclosed; just legal notice.
- * Informational meeting for residents held at Carriage on Sunday, March 1 - five months after Mr. Dombac's note and three days prior to the proposal going to the Planning and Zoning Commission. Some residents receive notice prior to meeting. Others receive notice of March 1 meeting on Tuesday, March 3 after the meeting was held - which was mailed on Saturday, February 28 and could not possibly arrive until after the meeting was held.

Dear Neighbors,

You're cordially invited to an informational meeting on Sunday, March 1st at 2:00 P.M. at Carriage Greens Country Club.

We would like to share with you the purpose for the request to amend our special use permit that would incorporate a practice facility.

We will be sharing the business plans and the exhibits of the facility. We would also like to answer any questions or concerns that our neighbors may have.

If you cannot attend and are interested in learning more, please feel free to contact David Prange at 630-985-3400.

Sincerely,

David Prange

David Prange

Carriage Greens Country Club

Director of Golf

PGA Professional



8700 CARRIAGE GREENS DRIVE
DARIEN, IL 60561

*Sent
Sat, Feb 28
12:00 PM
Tue, March 3*

CAROL STREAM IL 601

28 FEB 2015 PM 11

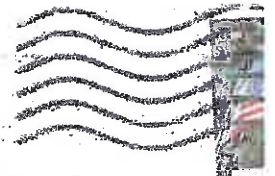

*Delivered to Carol Schafer
8621 Creekside Ln*

Michael Griffith

From: Frank Noverini <frank.nov@comcast.net>
Sent: Saturday, February 28, 2015 2:25 PM
To: Bryon Vana; Michael Griffith; Dale Schaefer; Frank Noverini
Subject: Fwd: Carriage Green PZC 2015-02 Ordinance O-31-72

Sent from my iPhone

Begin forwarded message:

From: Frank Noverini <frank.nov@comcast.net>
Date: February 28, 2015, 2:17:13 PM CST
To: Frank Noverini <frank.nov@comcast.net>
Subject: Carriage Green PZC 2015-02 Ordinance O-31-72

Just want to show you what weather and high winds do to this type of netting.
Also being in a flood plain how far down will posts have to be put in?
With all that netting and hitting of golf balls it will take away from the value of the homes.
How can we trust the golf course maintaining the netting? They can't even keep up with the missing and rundown fence they have around the maintenance building that's in back of the proposed site. That fence has been like that for years.

Frank Noverini
8613 Creekside Ln
Darien IL
630 985 0935
Sent from my iPhone

Michael Griffith

From: Barbara Carkhuff <bcarkhuffesl@gmail.com>
Sent: Tuesday, March 10, 2015 4:24 PM
To: Dan Gombac
Cc: Michael Griffith; Bryon Vana; Joe Marchese; Kathy Weaver
Subject: Planning and Zoning Concern

Hi,

This e-mail is from Don and Barb Carkhuff, 8509 Creekside Lane.

We would like to express our concern over the building of golf netting behind our house. I have basement sump pump problems right now and I feel this construction may increase my already poor position. I have installed auxillary sump pumps that are battery operated to help address my problem.

I spoke at the March 4th meeting and was glad to have that opportunity. At that meeting I stated that I would hate to see any netting. Darien truly is a nice place to live. Our website and city signs state this and I love living here. Any consideration of allowing any netting would NOT contribute to a nice place to live.

The netting installer was a man from North Aurora, I forget his name. He mentioned that he had done installations for schools. I think it would be a good idea for you all to personally see some of his installations and see what these nets look like when you are standing near them. This will give you some empirical evidence to help you make a decision.

Thanks so much for reading this e-mail.

Michael Griffith

From: Kathy Paskvan <Kathy.Paskvan@dart.biz>
Sent: Saturday, February 28, 2015 1:24 PM
To: Michael Griffith
Subject: Carriage Greens

My husband, Neal, and I support the request for Carriage Greens. They are a large employer in Darien and their request makes sense.

Kathy and Neal Paskvan
2333 Green Valley Road
Darien, IL

Michael Griffith

From: Pete Stukas <pstukas@v3co.com>
Sent: Wednesday, April 15, 2015 6:15 PM
To: Michael Griffith
Subject: Carriage Greens Driving Range

Hi Mike,

Thank you for taking the time to speak with me earlier this afternoon. As we discussed, I am in full support of the driving range variance and wanted to have my support entered into the record. I was hoping to be at the meeting in person, but am unable to do so. Below are my comments:

Peter Stukas
1618 Royal Oak Road
Darien, IL 60561

I have lived adjacent to the golf course for over 11 years. In that time, I have seen a course I enjoyed playing in the past fall into a condition such that I would no longer play there myself or bring friends to play there. This mismanagement was extremely disappointing. I am very much encouraged by the new management's plans not only for the driving range, but also for the course and grounds. The proposed improvements are long overdue. Not only will it be a place where we will be proud to bring our friends, but it will also be a place where our kids can learn the game and carry it on to the next generation. It is about time that we have golf professionals committed to make an investment in our local course and I feel that all Darien residents, the Planning and Zoning Commission and the City Council should join in that support.

The plans for the course work very well with the investment the City is making to redevelop the retail area along Cass Avenue and the overall efforts to upgrade our city. I have spoken to my neighbors and have heard nothing but support for the project.

Thanks again for the opportunity to present my comments.

Regards,

Pete

Peter Stukas, P.E.
Senior Project Manager
V3 Companies of Illinois, Ltd.
Cell: 630.675.7336
Pstukas@v3co.com

AGENDA MEMO
MUNICIPAL SERVICES COMMITTEE
MEETING DATE: April 27, 2015
Updated Information on page 2

Issue Statement

Neighborhood Parking Issues/Hinsdale South High School: Discussion regarding overflow Hinsdale South High School special event parking on Poplar Lane, Eleanor Place and Elm Street.

Background

Earlier this year, the City Council adopted regulations to address over flow event parking at Hinsdale South High School on Brookbank Road, Evans Place and Elm Street. Since those regulations have been in place, over flow parking has moved east to Poplar Lane, Eleanor Place and further east on Elm Street.

The City's elected officials and staff continues to receive complaints regarding the overflow parking on adjacent neighborhood streets during special events held by Hinsdale South High School. Many residents do not like the overflow parking occurring in front of their residences. Since the area is a rural cross section, many of the vehicles tend to park off the road edge/shoulder and in the turf area of the right of way, thus causing additional damage. The staff had consulted with the City's traffic engineer, KLOA, regarding the concern. Attachment A is a report dated November 27, 2013 from KLOA.

On May 19, 2014, the City Council approved the following ordinance regulating parking on Brookbank Road, Evans Place and Elm Street. The regulations are:

Brookbank Road, east side, between Janet Avenue and Elm Street, no high school or event parking any time.

Brookbank Road, west side, between Janet Avenue and Elm Street, no high school parking.

Elm Street, north side, between Clarendon Hills Road and Eleanor Place, no high school or event parking any time.

Evans Place, between Janet Avenue and Elm Street, on both sides of the street, no high school or event parking any time.

Staff Findings/Recommendation

Staff recommends surveying area residents to seek their input for the following options:

OPTION 1:

Eleanor Place and Poplar Lane, between Janet Avenue and Elm Street, on both sides of the street, no high school or event parking any time.

Or...

OPTION 2:

- A. Eleanor Place and Poplar Lane, east side, between Janet Avenue and Elm Street, no high school or event parking any time.
- B. Eleanor Place and Poplar Lane, west side, between Janet Avenue and Elm Street, no high school parking.

A map is attached showing the proposed roadways to be effected.

Municipal Services Committee Review – October 27, 2014

The Municipal Services Committee discussed this matter at their October 27, 2014, meeting. The following members were present: Alderman Joseph Marchese – Chairman, Alderman Tina Beilke, Alderman Joerge Seifert, Dan Gombac – Director, Michael Griffith – Senior Planner and Elizabeth Lahey – Secretary.

Dan Gombac, Director, stated complaints have been received concerning high school event parking occurring on Poplar and Eleanor. He offered two options explained in the memo.

After discussion, the Committee decided to recommend Option 1:

Eleanor Place and Poplar Lane, between Janet Avenue and Elm Street, on both sides of the street, no high school or event parking any time.

The Committee noted the high school needs to address their parking needs.

Mr. Gombac stated residents would get a letter indicating the proposed parking regulations and given the opportunity to comment.

Municipal Services Committee – November 24, 2014

Staff sent a letter to residents noting the proposed regulations as well as asking for their input, 34 letters sent out, 8 responses received. The responses are included with this memo.

Staff Recommendation

Staff recommends no action be taken at this time.

Municipal Services Committee – April 27, 2015

UPDATE: Recently, Alderman Beilke received correspondence from a resident on Eleanor Place regarding parking due to the baseball games. Resident is upset they need to continuously restore the turf.

Decision Mode

Municipal Services Committee: October 27, 2014
Municipal Services Committee: November 24, 2014
Municipal Services Committee: April 27, 2015

AGENDA MEMO
Municipal Services Committee
April 27, 2015

ISSUE STATEMENT

Approval of an Ordinance Authorizing the Sale of Personal Property Owned by the City of Darien.

BACKGROUND/HISTORY

Staff is requesting that the following property be declared as surplus property and auctioned using an on-line auction service, Public Surplus, or disposed of:

ITEM	EXPLANATION
1 Water Meters	The Staff replaces residential and commercial water meters when they are not operating properly with new meters. The meters are constructed of brass and have a salvage scrap metal value.
2 Water Fittings	The Staff replaces various brass and copper components as related to the potable water system. The parts are constructed of brass and copper and have a salvage scrap metal value.

STAFF RECOMMENDATION

Staff recommends approval of an Ordinance authorizing the sale of personal property owned by the City of Darien through Public Surplus.

ALTERNATE CONSIDERATION

Not approving this ordinance at this time would be an alternate consideration.

DECISION MODE

This item will be placed on the May 4, 2015, City Council Agenda for formal approval.

**CITY OF DARIEN
DU PAGE COUNTY, ILLINOIS**

ORDINANCE NO. _____

**AN ORDINANCE AUTHORIZING THE SALE
OF PERSONAL PROPERTY
OWNED BY THE CITY OF DARIEN**

**ADOPTED BY THE
MAYOR AND CITY COUNCIL
OF THE
CITY OF DARIEN
THIS 4th DAY OF MAY, 2015**

**Published in pamphlet form by authority
of the Mayor and City Council of the City
of Darien, DuPage County, Illinois, this __
_____ day of May, 2015.**

ORDINANCE NO. _____

**AN ORDINANCE AUTHORIZING THE SALE
OF PERSONAL PROPERTY
OWNED BY THE CITY OF DARIEN**

WHEREAS, in the opinion of at least three fourths of the corporate authorities of the City of Darien, it is no longer necessary or useful, or for the best interests of the City of Darien, to retain ownership of the personal property hereinafter described; and

WHEREAS, it has been determined by the Mayor and City Council of the City of Darien to sell said personal property at a Public Auction or dispose of said property.

NOW, THEREFORE, BE IT ORDAINED BY THE CITY COUNCIL OF THE CITY OF DARIEN, DU PAGE COUNTY, ILLINOIS, IN THE EXERCISE OF ITS HOME RULE POWERS, as follows:

SECTION 1: The Mayor and City Council of the City of Darien find that the following described personal property, now owned by the City of Darien, is no longer necessary or useful to the City of Darien and the best interests of the City of Darien will be served by auctioning it using Public Surplus or disposing of said property.

ITEM	EXPLANATION
1 Water Meters	The Staff replaces residential and commercial water meters when they are not operating properly with new meters. The meters are constructed of brass and have a salvage scrap metal value.
2 Water Fittings	The Staff replaces various brass and copper components as related to the potable water system. The parts are constructed of brass and copper and have a salvage scrap metal value.

ORDINANCE NO. _____

SECTION 2: The City Administrator is hereby authorized and directed to sell the aforementioned personal property, now owned by the City of Darien. Items will be auctioned using Public Surplus or disposing of said property.

SECTION 3: This Ordinance and each of its terms shall be the effective legislative act of a home rule municipality without regard to whether such Ordinance should (a) contain terms contrary to the provisions of current or subsequent non-preemptive state law, or (b) legislate in a manner or regarding a matter not delegated to municipalities by state law. It is the intent of the corporate authorities of the City of Darien that to the extent that the terms of this Ordinance should be inconsistent with any non-preemptive state law, that this Ordinance shall supersede state law in that regard within its jurisdiction.

SECTION 4: This Ordinance shall be in full force and effect from and after its passage and approval as provided by law.

PASSED BY THE CITY COUNCIL OF THE CITY OF DARIEN, DU PAGE COUNTY, ILLINOIS, this 4th day of May, 2015.

AYES: _____

NAYS: _____

ABSENT: _____

ORDINANCE NO. _____

**APPROVED BY THE MAYOR OF THE CITY OF DARIEN, DU PAGE
COUNTY, ILLINOIS, this 4th day of May, 2015.**

KATHLEEN MOESLE WEAVER, MAYOR

ATTEST:

JOANNE E. RAGONA, CITY CLERK

APPROVED AS TO FORM:

CITY ATTORNEY

AGENDA MEMO
Municipal Services Committee
April 27, 2015

ISSUE STATEMENT

Approval of a Resolution to enter into a contract agreement with Morton Salt for the purchase of rock salt in an amount not to exceed \$239,707.32.

BACKGROUND/HISTORY

The rock salt is utilized by the Municipal Services Department for street de-icing operations during the snow season. The City utilized approximately 3250 tons of salt this past season and has approximately 125 tons remaining within the salt storage building.

The City had partnered with the County of DuPage for the purchase of rock salt for the 2014/15 season. The lowest competitive price was Morton Salt in the amount of \$70.44 per ton. The County of Dupage recently negotiated with Morton Salt to extend the unit pricing for the 2015-16 season. See attached e-mail labeled As Attachment A.

As part of the joint contract the City has the ability to take up to 3,400 tons of sodium chloride salt. The Darien Park District and Center Cass School District #66 will be purchasing up to 245 and 8 tons respectively of rock salt not to exceed \$17,821.32. Forthcoming agenda memos will cover the Intergovernmental Agreements between the City and the Darien Park District and Center Cass School District #66. The City will have an opportunity to purchase approximately an additional 700 tons due to extreme conditions such as this past season. Staff will request City Council approval should conditions warrant the emergency expense.

The proposed expenditure would be expended from the following account:

ACCOUNT NUMBER	ACCOUNT DESCRIPTION	FY 15-16 BUDGET	PROPOSED EXPENDITURE	PROPOSED BALANCE
03-60-4249	CITY OF DARIEN 3,150 Tons	\$225,500	\$ 221,886.00	\$3,614.00
01-30-4249	DARIEN PARK DISTRICT-REIMBURSABLE 245 Tons	N/A	\$ 17,257.80	N/A
01-30-4249	DISTRICT 66-REIMBURSABLE 8 Tons	N/A	\$ 563.52	N/A
TOTAL COSTS			\$ 239,707.32	\$3,614.00

STAFF RECOMMENDATION

Staff recommends approval of this resolution with Morton Salt for the annual purchase of rock salt in an amount not to exceed \$ 239,707.32.

ALTERNATE CONSIDERATION

Not approving the contract.

DECISION MODE

This item will be placed on the May 4, 2015 City Council agenda for formal approval.

From: [Garza, Darcie \(DOT\)](#)
To: ["richkaske@comcast.net"](#); ["hwytsp@ameritech.net"](#); ["lawrence.anderson@dgtownship.com"](#); ["highway@lissetownship.com"](#); ["mthd@miltonhighway.com"](#); ["stan@napervilletownship.com"](#); ["road@winfieldtownship.com"](#); ["yorkhwy@comcast.net"](#); ["wtrd@sbcglobal.net"](#); ["pmodaff@carolstream.org"](#); ["mamos@villageofisle.org"](#); ["dlawry@villageofschaumburg.com"](#); ["ddinges@vbartlett.org"](#); ["mramsey@westmont.il.gov"](#); ["mmillette@clarendonhills.us"](#); ["Kim.McGrew@elmhurst.org"](#); ["rflatter@westchicago.org"](#); ["msmith@warrenville.il.us"](#); ["Jschouten@wheaton.il.us"](#); ["krubach@wooddale.com"](#); ["gpeluso@villageofhinsdale.org"](#); ["dbuckley@glenellyn.org"](#); ["bweiler@aurora-il.org"](#); ["ahendrey@addison-il.org"](#); ["dgombac@darienil.gov"](#); ["cbethel@vil.woodridge.il.us"](#); ["Cbarrett@villageofwinfield.com"](#); ["pmay@burr-ridge.gov"](#); ["goldsmithc@villageoflombard.org"](#); ["sweber@hpil.org"](#); ["thalik@willowbrook.il.us"](#); ["rhitchcock@itasca.com"](#); ["sbalicki@downers.us"](#); ["lewene@vil.bloomingtondale.il.us"](#); ["cjohnson@roselle.il.us"](#); ["jcaracci@bensenville.il.us"](#); ["richs@inwillapark.com"](#); ["schwartzhoff@naperville.il.us"](#); ["kimhernandez@dgtownship.com"](#); ["jelas@villageofisle.org"](#); ["tloomis@villageofwinfield.com"](#); ["monkmeyerJ@vil.bloomingtondale.il.us"](#); ["rradde@bensenville.il.us"](#); ["Scott_Nielsen@glendaleheights.org"](#); ["HOLLYBETH_WOOD"](#); ["lhammer@oak-brook.org"](#); ["Schwartzhoff, Christine"](#); ["JMcDermott@addison-il.org"](#); ["Lewen, Ed"](#)
Subject: FW: 2015/2016 BULK ROCK SALT
Date: Tuesday, March 31, 2015 1:07:19 PM
Attachments: [MORTON SALT RENEWAL LETTER.pdf](#)
[PARTICIPATING ENTITIES AND QUANTITIES.pdf](#)
Importance: High

From: Garza, Darcie (DOT)
Sent: Tuesday, March 31, 2015 1:00 PM
To: 'richkaske@comcast.net'; 'hwytsp@ameritech.net'; 'lawrence.anderson@dgtownship.com'; 'highway@lissetownship.com'; 'mthd@miltonhighway.com'; 'stan@napervilletownship.com'; 'road@winfieldtownship.com'; 'yorkhwy@comcast.net'; 'wtrd@sbcglobal.net'; 'pmodaff@carolstream.org'; 'mamos@villageofisle.org'; 'dlawry@villageofschaumburg.com'; 'ddinges@vbartlett.org'; 'mramsey@westmont.il.gov'; 'mmillette@clarendonhills.us'; 'Kim.McGrew@elmhurst.org'; 'rflatter@westchicago.org'; 'msmith@warrenville.il.us'; 'Jschouten@wheaton.il.us'; 'krubach@wooddale.com'; 'gpeluso@villageofhinsdale.org'; 'dbuckley@glenellyn.org'; 'bweiler@aurora-il.org'; 'ahendrey@addison-il.org'; 'dgombac@darienil.gov'; 'cbethel@vil.woodridge.il.us'; 'Cbarrett@villageofwinfield.com'; 'pmay@burr-ridge.gov'; 'goldsmithc@villageoflombard.org'; 'sweber@hpil.org'; 'thalik@willowbrook.il.us'; 'rhitchcock@itasca.com'; 'sbalicki@downers.us'; 'lewene@vil.bloomingtondale.il.us'; 'cjohnson@roselle.il.us'; 'jcaracci@bensenville.il.us'; 'richs@inwillapark.com'; 'schwartzhoff@naperville.il.us'; 'kimhernandez@dgtownship.com'; 'jelas@villageofisle.org'; 'tloomis@villageofwinfield.com'; 'monkmeyerJ@vil.bloomingtondale.il.us'; 'rradde@bensenville.il.us'; 'Scott_Nielsen@glendaleheights.org'; 'HOLLYBETH_WOOD'; 'lhammer@oak-brook.org'; 'Schwartzhoff, Christine'; 'JMcDermott@addison-il.org'; 'Lewen, Ed'
Cc: Snyder, Christopher; Kawka, John
Subject: FW: 2015/2016 BULK ROCK SALT
Importance: High

From: Garza, Darcie (DOT)
Sent: Tuesday, March 31, 2015 12:57 PM
To: 'richkaske@comcast.net'; 'hwytsp@ameritech.net'; 'lawrence.anderson@dgtownship.com'; 'highway@lissetownship.com'; 'mthd@miltonhighway.com'; 'stan@napervilletownship.com'; 'road@winfieldtownship.com'; 'yorkhwy@comcast.net'; 'wtrd@sbcglobal.net'; 'pmodaff@carolstream.org'; 'mamos@villageofisle.org'; 'dlawry@villageofschaumburg.com'; 'ddinges@vbartlett.org'; 'mramsey@westmont.il.gov'; 'mmillette@clarendonhills.us'; 'Kim.McGrew@elmhurst.org'; 'rflatter@westchicago.org'; 'msmith@warrenville.il.us'; 'Jschouten@wheaton.il.us'; 'krubach@wooddale.com'; 'gpeluso@villageofhinsdale.org'; 'dbuckley@glenellyn.org'; 'bweiler@aurora-il.org'; 'ahendrey@addison-il.org'; 'dgombac@darienil.gov'; 'cbethel@vil.woodridge.il.us'; 'Cbarrett@villageofwinfield.com'; 'pmay@burr-ridge.gov'; 'goldsmithc@villageoflombard.org'; 'sweber@hpil.org'; 'thalik@willowbrook.il.us';

'rhitchcock@itasca.com'; 'sbalicki@downers.us'; 'lewene@vil.bloomingtondale.il.us'; 'cjohnson@roselle.il.us'; 'jcaracci@bensenville.il.us'; 'richs@invillapark.com'; 'schwartzhoff@naperville.il.us'; 'kimhernandez@dgtownship.com'; 'jelijias@villageofisle.org'; 'tloomis@villageofwinfield.com'; 'monkmeyerJ@vil.bloomingtondale.il.us'; 'rradde@bensenville.il.us'; Scott_Nielsen@glendaleheights.org; HOLLYBETH_WOOD (hollybeth_wood@glendaleheights.org); lhammer@oak-brook.org; Schwartzhoff, Christine (SchwartzhoffC@naperville.il.us); JMcDermott@addison-il.org; Lewen, Ed (LEWENE@vil.bloomingtondale.il.us)

Cc: Snyder, Christopher; Kawka, John

Subject: 2015/2016 BULK ROCK SALT

Importance: High

Good Morning DuPage County Salt Participants,

DuPage County has gotten positive response from our community partners to participate in DuPage County's 2015/16 salt bid. Last year's bid price was \$70.44/ton which was very favorable as compared to those that bid through other source(s). Early bidding this year by some agencies has resulted in bids in the range of \$80-85/ton. We have reached out to our supplier, Morton, who is willing to **renew** at last year's pricing and would be willing to include DuPage County communities (see attached letter). Given the bid pricing received to date and the heavy snow on the east coast, we believe that \$70.44/ton is a good price and the County intends to move forward with renewing last year's contract. Attached is a summary of DuPage communities that have provided the County with 2015/2016 quantities as well as a copy of our bid specs from last year. If your community is interested in the renewal offer by Morton, please complete the attached form and fax back to Morton's representative **by April 24th**. By signing, you agree to purchase the quantity(ies) listed on the attached for your community. It will be up to each community to ultimately contract directly with Morton.

SEE E-MAIL ATT DATED APRIL 4, 2015 - GRANTING EXTENSION OF TIME

Last year's bid specs specified an early buy of September 30th. We have asked Morton if that **can** be extended to 11/30 and will advise you of their response.

I have included the following attachments: The Renewal Letter, that will be signed and returned to Morton, the list that shows all the participating entities and their corresponding quantities and last years' bid documents for your perusal (this attachment will be sent under separate cover).

If I can be of any assistance or you have any questions, feel free to call or email.

Darcie Garza, CPPB

Darcie Garza, CPPB
DuPage County Division of Transportation – Highway Maintenance Division
140 N. County Farm Road
Wheaton, IL 60187

(630)407-6906 – Phone

(630)407-6921 – Fax

Darcie.garza2@dupageco.org - Email

SHIPPING AND BILLING INFORMATION: GROUP 2 – ADDITIONAL LOCATIONS

Bill To:	Ship To:	A-100% Confirmed Quantities – Delivery before September 30, 2015	B-80-130% Estimated Quantities – Standard Delivery (100% Usage Quantity noted)
City of Wheaton Public Works Mike Wakefeld 821 Liberty Drive Wheaton, IL 60189	City of Wheaton Public Works Marla 821 Liberty Drive Wheaton, IL 60189	NONE	3300 Tons
Village of Carol Stream Phil Modaff 500 N. Gary Ave. Carol Stream, IL 60188	Carol Stream Public Works Facility – Todd Hoppenstedt 124 Gerzevske Lane Carol Stream, IL 60188	NONE	2100 Tons
Village of Woodridge Public Works Sandy Allworth One Plaza Drive Woodridge, IL 60517	Village of Woodridge Public Works Scott Sramek One Plaza Drive Woodridge, IL 60517	500 Tons	1400 Tons
Village of Winfield Sandy Sprague 27W 465 Jewel Road Winfield, IL 60190	Village of Winfield Public Works Main Site– Tye Loomis 0S040 Wynwood Road Winfield, IL 60190	200 Tons	500 Tons
Village of Hinsdale George Peluso 19 E. Chicago Ave. Hinsdale, IL 60521	Village of Hinsdale George Peluso 225 Symonds Dr. Hinsdale, IL 60521	NONE	600 Tons
Village of Downers Grove Terri Tarka 801 Burlington Ave. Downers Grove, IL 60515	Village of Downers Grove Stan Balicki 5101 Walnut Ave. Downers Grove, IL 60515	NONE	2000 Tons
Village of Glen Ellyn David Buckley 30 S. Lambert Road Glen Ellyn, IL 60137	Village of Glen Ellyn David Buckley 30 S. Lambert Road Glen Ellyn, IL 60137	200 Tons	2000 Tons
Village of Bensenville Department of Public Works Virginia Lavorata 717 E. Jefferson Bensenville, IL 60106	Village of Bensenville Rick Radde 717 E. Jefferson St. Bensenville, IL 60106	NONE	500 Tons
City of Aurora, Illinois Esther Phillips 44 E. Downer Place Aurora, IL 60505	City of Aurora Central Garage Brett Weller 720 N. Broadway Aurora, IL 60505	NONE	7000 Tons
Village of Villa Park Rich Salerno 20 South Ardmore Ave. Villa Park, IL 60181	Village of Villa Park Salt Storage Yard Rich Salerno 729 North Ardmore Ave. Villa Park, IL 60181	NONE	500 Tons
City of Darien Dan Gornbac 1041 S. Frontage Road Darien, IL 60561	City of Darien Daniel Salvato 1041 S. Frontage Rd. Darien, IL 60561	1400 Tons	2000 Tons

Dan Gombac

From: djones@mortonsalt.com
Sent: Wednesday, April 01, 2015 4:38 PM
To: Dan Gombac
Cc: Bryon Vana
Subject: RE: 20115/16 Salt-Darien City

Hello
Yes we can wait the email of intent will be ok for now.



Deborah Jones
Deicing Sales Representative
Morton Salt, Inc. | A K+S Group Company
P: +1 708.891.5847 | W: MortonSalt.com

From: Dan Gombac [mailto:dgombac@darienil.gov]
Sent: Wednesday, April 01, 2015 2:38 PM
To: Jones, Deborah
Cc: Bryon Vana
Subject: RE: 20115/16 Salt-Darien City

Good afternoon Debbi:

The City of Darien was recently notified through Dupage County that Morton Salt has extended the salt unit prices for the 15/16 season. As per the attached letter the City of Darien will participate. I plan on requesting Committee approval on April 26 followed by City Council approval for May 4, 2016. According to the attached letter we are required to respond within 30 days or by April 26, 2015. Will Morton allow us to have a resolution out to you on Tues, May 5, 2015?

Sincerely,

Daniel Gombac
Director of Municipal Services
630-353-8106

To receive important information from the City of Darien sign up for our electronic newsletter:

DARIEN DIRECT CONNECT

Follow the link below and subscribing is simple!

<http://www.darien.il.us/Departments/Administration/CityNews.html>

From: djones@mortonsalt.com [mailto:djones@mortonsalt.com]
Sent: Monday, May 19, 2014 1:53 PM

RESOLUTION NO. _____

A RESOLUTION TO ENTER INTO A CONTRACT AGREEMENT WITH MORTON SALT FOR THE PURCHASE OF ROCK SALT IN AN AMOUNT NOT TO EXCEED \$239,707.32

BE IT RESOLVED BY THE CITY COUNCIL OF THE CITY OF DARIEN, DU PAGE COUNTY, ILLINOIS, as follows:

SECTION 1: The City Council of the City of Darien hereby authorizes the Mayor to enter into a contract agreement with Morton Salt for the purchase of rock salt in an amount not to exceed \$239,707.32, a copy of which is attached hereto as "Exhibit A".

SECTION 2: This Resolution shall be in full force and effect from and after its passage and approval as provided by law.

PASSED BY THE CITY COUNCIL OF THE CITY OF DARIEN, DU PAGE COUNTY, ILLINOIS, this 4th day of May, 2015.

AYES: _____

NAYS: _____

ABSENT: _____

APPROVED BY THE MAYOR OF THE CITY OF DARIEN, DU PAGE COUNTY, ILLINOIS this 4th day of May, 2015.

KATHLEEN MOESLE WEAVER, MAYOR

ATTEST:

JOANNE E. RAGONA, CITY CLERK

APPROVED AS TO FORM:

CITY ATTORNEY



March 26, 2015

DuPage County Procurement Services Division
Attn: Darcie Garza
421 North County Farm Road, Room 3-400
Wheaton, IL 60187-3978

Dear Darcie Garza:

Morton Salt, Inc. is pleased to offer an extension per your request of your current contract for Bulk Safe-T-Salt.

This extension is offered at \$70.44 per ton. All terms and conditions will remain the same from June 1, 2015 thru May 31, 2016.

Morton Salt must receive acceptance from all participating agencies by signing below and faxing to me at: 312/807-2669. After 30 days this offer is automatically rescinded.

Thank you for this opportunity to serve your ice control needs another season. If you need further information, please call our Sales Representative Debbi Jones at: 708/891-5847.

Very truly yours,

Anthony T. Patton
Director, U.S. Government Bulk Deicing
Sales & Marketing

Accepted:

By _____

Name _____

Title _____

Township _____

Phone _____

Date _____

cc: Debbi Jones

AGENDA MEMO
Municipal Services Committee
April 27, 2015

Issue Statement

Approval of a Resolution authorizing the Mayor to execute an Intergovernmental Agreement with the Darien Park District for the reimbursement of Rock Salt through the City's 2015/16 Rock Salt Agreement.

Background/History

The Intergovernmental Agreement with the Darien Park District authorizes the City of Darien to provide rock salt to the Darien Park District for their deicing operations. The Park District does not have facilities to accommodate rock salt in bulk and will realize a savings by utilizing the City's bulk pricing and storage facility.

The Park District has estimated that they will require approximately 245 tons for the winter season. The City of Darien would be reimbursed by the Park District at a unit cost of \$70.44 per ton for a total amount of approximately \$17,257.80 pending final quantities.

Staff Recommendation

Staff recommends signing the Intergovernmental Agreement.

Alternate Consideration

Not approving the Resolution.

Decision Mode

This item will be placed on the May 4, 2015 City Council agenda for formal consideration.

RESOLUTION NO. _____

**A RESOLUTION AUTHORIZING THE MAYOR TO EXECUTE AN
INTERGOVERNMENTAL AGREEMENT BETWEEN THE CITY OF DARIEN
AND THE DARIEN PARK DISTRICT
FOR ROCK SALT**

WHEREAS, under the Constitution and Statues of the State of Illinois, a municipality is authorized to participate in intergovernmental cooperation; and

WHEREAS, an Intergovernmental Agreement has been prepared between the City of Darien and the Darien Park District concerning the purchase of rock salt, a copy of which is attached hereto as “Exhibit A,” and is incorporated herein; and

WHEREAS, The Corporate Authorities, for record keeping, desire to authorize the execution of the Intergovernmental Agreement by Resolution.

NOW, THEREFORE, BE IT RESOLVED BY THE CITY COUNCIL OF THE CITY OF DARIEN, DUPAGE COUNTY, as follows:

SECTION 1: That the Mayor is hereby authorized to execute an Intergovernmental Agreement for the purchase of rock salt, subject to the Darien Park District Intergovernmental Agreement paying for the final quantities.

The obligations of the City of Darien shall be limited to those specifically stated within the terms of the Intergovernmental Agreement.

SECTION 2: This Resolution shall be in full force and effect from and after its passage and approval as provided by law.

RESOLUTION NO. _____

**PASSED BY THE CITY COUNCIL OF THE CITY OF DARIEN, DUPAGE
COUNTY, ILLINOIS, this 4th day of May, 2015.**

AYES: _____

NAYS: _____

ABSENT: _____

**APPROVED BY THE MAYOR FOR THE CITY OF DARIEN, DUPAGE
COUNTY, ILLINOIS, this 4th day of May, 2015.**

KATHLEEN MOESLE WEAVER, MAYOR

ATTEST:

JOANNE E. RAGONA, CITY CLERK

APPROVED AS TO FORM:

CITY ATTORNEY

**INTERGOVERNMENTAL AGREEMENT
BETWEEN THE CITY OF DARIEN AND THE DARIEN PARK DISTRICT
FOR THE PURCHASE OF ROAD SALT**

This agreement is made and entered into this _____ day of _____, 2015, by and between the City of Darien, an Illinois municipal corporation (hereinafter the “City”), and the Darien Park District, an Illinois municipal corporation, (hereinafter the “District”) (collectively “the parties”).

WHEREAS, the corporate authorities of the parties possess authority to enter into this intergovernmental agreement pursuant to Article VII, Section 10 of the 1970 Constitution of the State of Illinois and pursuant to the provisions of the Illinois Intergovernmental Cooperation Act, 5 ILCS 220/1, *et seq.*;

WHEREAS, the City desires to assist the District by allowing the District to purchase rock salt from the Public Works facility for an estimated cost of \$17,257.80 pending final quantities;

WHEREAS, the parties desire to commit their agreements and understandings to writing;

NOW, THEREFORE, in consideration of the mutual covenants contained in this Agreement, the parties hereto agree, as follows:

1. The recitals set forth above are hereby incorporated into and made a part of this Agreement.
2. The District authorizes the City to provide rock salt to the District for de-icing operations.
3. The District shall reimburse the City for the rock salt charges by April 30, 2016 as invoiced by the City.

4. All notices, requests and other communications under this Agreement shall be in writing and shall be deemed properly served upon delivery by hand to the party to whom it is addressed, or upon receipt, if sent, postage pre-paid by United States registered or certified mail, return receipt requested, as follows:

a. If intended for the City:

City of Darien
1702 Plainfield Road
Darien, Illinois 60561
Attn: Bryon Vana

b. If intended for the Park District:

Darien Park District
7301 Fairview Avenue
Darien, Illinois 60561
Attn: Stephanie Gurgone

5. The validity, meaning, and effect of this Agreement shall be determined in accordance with the laws of the State of Illinois applicable to intergovernmental agreements made and contracts made and to be formed in Illinois.

IN WITNESS WHEREOF, the parties hereto have caused this Agreement to be executed in their respective corporate names, by the authorized signatures of their respective officers and by their respective corporate seals affixed and attached hereto by their respective officers having custody thereof on this _____ day of _____, 2015.

CITY OF DARIEN

BY: _____
Kathleen Weaver, Mayor

ATTEST: _____
JoAnne E. Ragona, City Clerk

DARIEN PARK DISTRICT

BY: _____
Ray Jablonski, President
Darien Park District

ATTEST: _____
Secretary, Park District

AGENDA MEMO
Municipal Services Committee
April 27, 2015

Issue Statement

Approval of a Resolution authorizing the Mayor to execute an Intergovernmental Agreement with Center Cass School District #66 for the reimbursement of Rock Salt through the City's 2015/16 Rock Salt Agreement.

Background/History

The Intergovernmental Agreement with Center Cass School District #66 authorizes the City of Darien to provide rock salt to Center Cass School District #66 for their deicing operations. The School District does not have facilities to accommodate rock salt in bulk and will realize a savings by utilizing the City's bulk pricing and storage facility.

The School District has estimated that they will require approximately 8 tons for the winter season. The City of Darien would be reimbursed by the School District at a unit cost of \$70.44 per ton for a total amount of approximately \$563.52 pending final quantities. The proposed salt quantities will not have any impact to the City's contract with the supplier.

Staff Recommendation

Staff recommends signing the Intergovernmental Agreement.

Alternate Consideration

Not approving the Resolution.

Decision Mode

This item will be placed on the May 4, 2015 City Council agenda for formal consideration.

RESOLUTION NO. _____

**A RESOLUTION AUTHORIZING THE MAYOR TO EXECUTE AN
INTERGOVERNMENTAL AGREEMENT BETWEEN THE CITY OF DARIEN
AND CENTER CASS SCHOOL DISTRICT #66
FOR ROCK SALT**

WHEREAS, under the Constitution and Statues of the State of Illinois, a municipality is authorized to participate in intergovernmental cooperation; and

WHEREAS, an Intergovernmental Agreement has been prepared between the City of Darien and Center Cass School District #66 concerning the purchase of rock salt, a copy of which is attached hereto as “Exhibit A,” and is incorporated herein; and

WHEREAS, The Corporate Authorities, for record keeping, desire to authorize the execution of the Intergovernmental Agreement by Resolution.

NOW, THEREFORE, BE IT RESOLVED BY THE CITY COUNCIL OF THE CITY OF DARIEN, DUPAGE COUNTY, as follows:

SECTION 1: That the Mayor is hereby authorized to execute an Intergovernmental Agreement for the purchase of rock salt, subject to the Center Cass School District #66 Intergovernmental Agreement paying for the final quantities.

The obligations of the City of Darien shall be limited to those specifically stated within the terms of the Intergovernmental Agreement.

SECTION 2: This Resolution shall be in full force and effect from and after its passage and approval as provided by law.

RESOLUTION NO. _____

**PASSED BY THE CITY COUNCIL OF THE CITY OF DARIEN, DUPAGE
COUNTY, ILLINOIS, this 4th day of May, 2015.**

AYES: _____

NAYS: _____

ABSENT: _____

**APPROVED BY THE MAYOR FOR THE CITY OF DARIEN, DUPAGE
COUNTY, ILLINOIS, this 4th day of May, 2015.**

KATHLEEN MOESLE WEAVER, MAYOR

ATTEST:

JOANNE E. RAGONA, CITY CLERK

APPROVED AS TO FORM:

CITY ATTORNEY

**INTERGOVERNMENTAL AGREEMENT
BETWEEN THE CITY OF DARIEN AND CENTER CASS SCHOOL DISTRICT #66
FOR THE PURCHASE OF ROAD SALT**

This agreement is made and entered into this ____ day of _____, 2015, by and between the City of Darien, an Illinois municipal corporation (hereinafter the “City”), and Center Cass School District #66, an Illinois municipal corporation, (hereinafter the “School District”) (collectively “the parties”).

WHEREAS, the corporate authorities of the parties possess authority to enter into this intergovernmental agreement pursuant to Article VII, Section 10 of the 1970 Constitution of the State of Illinois and pursuant to the provisions of the Illinois Intergovernmental Cooperation Act, 5 ILCS 220/1, *et seq.*;

WHEREAS, the City desires to assist the School District by allowing the School District to purchase rock salt from the Public Works facility for an estimated cost of \$563.52 pending final quantities;

WHEREAS, the parties desire to commit their agreements and understandings to writing;

NOW, THEREFORE, in consideration of the mutual covenants contained in this Agreement, the parties hereto agree, as follows:

1. The recitals set forth above are hereby incorporated into and made a part of this Agreement.
2. The District authorizes the City to provide rock salt to the District for de-icing operations.
3. The District shall reimburse the City for the rock salt charges by April 30, 2016 as invoiced by the City.
4. All notices, requests and other communications under this Agreement shall be in writing and shall be deemed properly served upon delivery by hand to the party to

whom it is addressed, or upon receipt, if sent, postage pre-paid by United States registered or certified mail, return receipt requested, as follows:

a. If intended for the City:

City of Darien
1702 Plainfield Road
Darien, Illinois 60561
Attn: Bryon Vana

b. If intended for the Park District:

Center Cass School District #66
699 Plainfield Road
Downers Grove, Illinois 60516
Attn: Timothy Arnold

5. The validity, meaning, and effect of this Agreement shall be determined in accordance with the laws of the State of Illinois applicable to intergovernmental agreements made and contracts made and to be formed in Illinois.

IN WITNESS WHEREOF, the parties hereto have caused this Agreement to be executed in their respective corporate names, by the authorized signatures of their respective officers and by their respective corporate seals affixed and attached hereto by their respective officers having custody thereof on this ____ day of _____, 2015.

CITY OF DARIEN

BY: _____
Kathleen Weaver, Mayor

ATTEST: _____
JoAnne E. Ragona, City Clerk

CENTER CASS SCHOOL DISTRICT #66

BY: _____
Timothy Arnold, Superintendent
Center Cass School District #66

ATTEST: _____
Secretary, School District

AGENDA MEMO
Municipal Services Committee
April 27, 2015

ISSUE STATEMENT

Approval to extend a contract through the attached resolution to Tru Green LP for five (5) various fertilizer applications in an amount not to exceed \$21,836.09, for the 2015 Landscape Fertilization Services at Roadside Rights of Way and Medians of 75th Street, certain segments of Plainfield Road and City owned detention facilities. Included also are City owned facilities such as the Water Plant grounds, the Public Works facility and the City Hall grounds.

BACKGROUND/HISTORY

On January 15, 2013 staff received three (3) bids for the proposed 2013 fertilization services, (See Attachment A). The contract also called out for two optional extensions for 2014 and 2015. The proposed extension will be the last extension of a three year contract. The fertilization program will allow the City to eradicate noxious weeds and provide uniform aesthetically pleasing turf throughout certain right of ways and City owned facilities.

The following areas would receive fertilizer applications throughout the year:

- 1) Certain median areas and roadside right of ways on 75th Street from Route 83 (Kingery Highway) west to Lemont Road-18.52 acres
- 2) Plainfield Road from Cass Avenue east to 75th Street- 2.00 acres

Total Acres 28.52 acres

City Owned Facilities:	<u>Acres</u>
City Hall 1702 Plainfield Rd	0.70
Public Works 1041 S Frontage Rd	1.70
Water Plant #2 1220 Plainfield Rd	.33
Water Plant #3 1930 Manning Rd	.57
Water Plant #4 1897 Manning Rd	.66
Water Plant #5 8600 Lemont Rd	.83
Water Stand Pipe 6709 Wilmette Ave	.11
Detention Facilities	<u>13.7</u>
Total Acres	18.60

The contract also entertained fertilization services for the City maintained median trees along 75th Street. The scope of work would include fertilizing 65 trees along 75th Street from Clarendon Hills Road west to Lemont Road. Staff recommends fertilizing the trees this year and will continue to monitor them.

The contract specifications included up to six (6) various fertilizer applications throughout the year. Staff is requesting that Applications 1, 2, 3, 4, and 5 for a total of five (5) applications be

2015 Landscape Fertilization Program

April 27, 2015

Page 2

implemented for the 2015 Program. (See Attachment B).

The proposed expenditure would be expended from the following accounts.

ACCOUNT NUMBER	ACCOUNT DESCRIPTION	FY 15/16 BUDGET	PROPOSED EXPENDITURE
01-30-4350	Forestry-Fertilization 75 th Street-Turf Areas	\$ 10,881.00	\$ 10,880.43
02-50-4223	Maintenance Building-Water Plants Maintenance	\$ 3,2000.00	\$ 1,280.61
01-30-4350	Maintenance Building-City Hall Grounds	\$ 360.00	\$ 358.57
01-30-4223	Maintenance Building-Base Maintenance	\$ 37,250	\$ 870.82
01-30-4350	Detention Facilities	\$ 8,500	\$ 7,445.65
01-30-4350	75 th Street Tree Fertilization	\$ 1,000	\$ 1,000.00
Total Cost - Fertilization			\$ 21,836.09

STAFF RECOMMENDATION

Staff recommends approval to extend a contract in an amount not to exceed \$21,836.09 for the City's 2015 Landscape Fertilization Services at Roadside Rights of Way and Medians and Specified City owned facilities to Tru Green, LP. Tru Green has provided very efficient services for the City of Darien since 2011.

ALTERNATE DECISION

Not approving the contract at this time would be an alternate decision.

DECISION MODE

This item will be placed on the April 6, 2015 City Council agenda for formal consideration.

**CITY OF DARIEN PUBLIC WORKS
1702 PLAINFIELD ROAD
DARIEN, IL 60561**

Attachment A

SEALED BID: 2013 Landscape Fertilization Program

OPENING DATE/TIME: January 15, 2013 @ 9:30 a.m.

ITEM		Spring Green Lawn Care			ASE Illini-Scapes Inc			Tru Green LP		
		Cashier's Check		Addendum	Bid bond		Addendum	Bid bond		Addendum
		2013-2014	2014-2015	2015-2016	2013-2014	2014-2015	2015-2016	2013-2014	2014-2015	2015-2016
		DESCRIPTION								
Section I	Application #1	\$ 2,890.00	\$ 2,890.00	\$ 2,890.00	\$ 3,700.00	\$ 3,811.00	\$ 3,925.00	\$ 2,900.00	\$ 2,900.00	\$ 2,900.00
	Application #2	\$ 3,190.00	\$ 3,190.00	\$ 3,190.00	\$ 4,200.00	\$ 4,326.00	\$ 4,456.00	\$ 3,200.00	\$ 3,200.00	\$ 3,200.00
	Application #3	\$ 3,990.00	\$ 3,990.00	\$ 3,990.00	\$ 4,500.00	\$ 4,635.00	\$ 4,774.00	\$ 4,000.00	\$ 4,000.00	\$ 4,000.00
	Application #4	\$ 2,690.00	\$ 2,690.00	\$ 2,690.00	\$ 3,200.00	\$ 3,296.00	\$ 3,395.00	\$ 2,700.00	\$ 2,700.00	\$ 2,700.00
	Application #5	\$ 2,690.00	\$ 2,690.00	\$ 2,690.00	\$ 3,200.00	\$ 3,296.00	\$ 3,395.00	\$ 2,700.00	\$ 2,700.00	\$ 2,700.00
	Application #6	\$ 1,990.00	\$ 1,990.00	\$ 1,990.00	\$ 1,800.00	\$ 1,854.00	\$ 1,910.00	\$ 1,500.00	\$ 1,500.00	\$ 1,500.00
Subtotal Section I		\$ 17,440.00	\$ 17,440.00	\$ 17,440.00	\$ 20,600.00	\$ 21,218.00	\$ 21,855.00	\$ 17,000.00	\$ 17,000.00	\$ 17,000.00
Section II	Application #1	\$ 410.00	\$ 410.00	\$ 410.00	\$ 636.00	\$ 655.00	\$ 674.00	\$ 420.00	\$ 420.00	\$ 420.00
	Application #2	\$ 500.00	\$ 500.00	\$ 500.00	\$ 722.00	\$ 743.00	\$ 766.00	\$ 510.00	\$ 510.00	\$ 510.00
	Application #3	\$ 710.00	\$ 710.00	\$ 710.00	\$ 773.00	\$ 796.00	\$ 820.00	\$ 720.00	\$ 720.00	\$ 720.00
	Application #4	\$ 420.00	\$ 420.00	\$ 420.00	\$ 550.00	\$ 566.00	\$ 583.00	\$ 430.00	\$ 430.00	\$ 430.00
	Application #5	\$ 420.00	\$ 420.00	\$ 420.00	\$ 550.00	\$ 566.00	\$ 583.00	\$ 430.00	\$ 430.00	\$ 430.00
	Application #6	\$ 280.00	\$ 280.00	\$ 280.00	\$ 309.00	\$ 319.00	\$ 328.00	\$ 230.00	\$ 230.00	\$ 230.00
Subtotal Section II		\$ 2,740.00	\$ 2,740.00	\$ 2,740.00	\$ 3,540.00	\$ 3,645.00	\$ 3,754.00	\$ 2,740.00	\$ 2,740.00	\$ 2,740.00
Section III		\$ 1,565.00	\$ 1,565.00	\$ 1,565.00	\$ 1,600.00	\$ 1,648.00	\$ 1,697.00	\$ 1,200.00	\$ 1,200.00	\$ 1,200.00
Grand Total		\$ 21,745.00	\$ 21,745.00	\$ 21,745.00	\$ 25,740.00	\$ 26,511.00	\$ 27,306.00	\$ 20,940.00	\$ 20,940.00	\$ 20,940.00

2015 FERTILIZATION PROGRAM

BID TALLY AND SUMMARY CONTRACT FOR 2015

SECTION I	From	Subject	Received	Size	Categories		
RIGHT OF WAY MAINTENANCE FERTILIZATION-28.52 ACRES	Ashley Prueter	2013 Landscape Fertilization bid results.x		2:10 PM 35 KB			
PROGRAM INCLUDES: 75TH STREET-NORTHERN, SOUTHERN RIGHT OF WAYS AND MEDIANS							
PLAINFIELD ROAD-CASS AVE AND 75TH STREET							
	AWARDED VENDOR	PROPOSED APPLICATIONS 2015	2015 BID TABULATION	2015 BID TABULATION	ADJUSTED PRICING WILLOWBROOK	REDUCT AS ACRES 75TH STREET WILLOWBROOK	REVISED CGSTS
ACCOUNT NO 01-30-4350	VENDOR	TRU GREEN	TRU GREEN	ASE-ILLINI SCAPES	SPRING GREEN	UNIT COST PER ACRE	SUSPENDED COSTS
	APPLICATION	2015 BID					
	Appl #1 March-April	\$ 2,900.00	\$ 2,900.00	3,925.00	2,890.00	\$ 101.68	\$ 2,035.69
	Appl #2 April-May	\$ 3,200.00	\$ 3,200.00	4,456.00	3,190.00	\$ 112.20	\$ 2,246.28
	Appl #3 May-June	\$ 4,000.00	\$ 4,000.00	4,774.00	3,990.00	\$ 140.25	\$ 2,807.85
	Appl #4 July-August	\$ 2,700.00	\$ 2,700.00	3,395.00	2,690.00	\$ 94.67	\$ 1,895.30
	Appl #5 September	\$ 2,700.00	\$ 2,700.00	3,395.00	2,690.00	\$ 94.67	\$ 1,895.30
	Appl #6 Nov-Dec	\$ 1,500.00	\$ -	1,910.00	1,990.00	\$ -	\$ -
	Subtotal Section I	\$ 17,000.00	\$ 15,500.00	\$ 21,855.00	\$ 17,440.00	\$ 543.48	\$ 10,880.43
CITY HALL GROUNDS	VENDOR	AWARDED VENDOR-TRU GREEN	PROPOSED APPLICATIONS 2015	2015 BID TABULATION	2015 BID TABULATION	ADJUSTED ACREAGE	
	APPLICATION	2015 BID	TRU GREEN	ASE-ILLINI SCAPES	SPRING GREEN	20.02	
	Appl.#1 March-April	\$ 420.00	\$ 420.00	\$ 674.00	\$ 410.00		
	Appl #2 April-May	\$ 510.00	\$ 510.00	\$ 766.00	\$ 500.00		
	Appl #3 May-June	\$ 720.00	\$ 720.00	\$ 820.00	\$ 710.00		
	Appl #4 July-August	\$ 430.00	\$ 430.00	\$ 583.00	\$ 420.00		
	Appl #5 September	\$ 430.00	\$ 430.00	\$ 583.00	\$ 420.00		
	Appl #6 Nov-Dec	\$ 230.00	\$ -	\$ 328.00	\$ 280.00		
	Subtotal Section II	\$ 2,740.00	\$ 2,510.00	\$ 3,754.00	\$ 2,740.00		
SECTION III							
TREE FERTILIZATION 250 TREES 75TH ST	APPLICATION	AWARDED VENDOR-TRU-GREEN	PROPOSED APPLICATIONS 2015	2015 BID TABULATION	2015 BID TABULATION	AWARDED VENDOR-TRU-GREEN	
		2015 BID	TRU GREEN	ASE-ILLINI SCAPES	SPRING GREEN	2015 BID	
	Tree Fertilization-75th St	\$ 1,200.00	\$ 1,000.00	\$ 1,648.00	\$ 1,565.00	\$ 1,000.00	
	Subtotal Section III	\$ 1,200.00	\$ 1,000.00	\$ 1,648.00	\$ 1,565.00	\$ 1,000.00	
	Total Cost Section I, II & III	\$ 14,820.43	\$ 14,390.43	\$ 27,257.00	\$ 21,745.00	\$ 14,390.43	
PER ACRE CALCULATION FOR PROPOSED CITY OWNED FACILITIES 2015 PROGRAM							
ACCOUNT CHARGE	02-50-4223	02-50-4223	ACCOUNT NO 01-30-4350	ACCOUNT NO 01-30-4350	ACCOUNT NO 01-30-4350	ACCOUNT NO 01-30-4350	TOTAL 15/16 PROGRAM COST
LOCATION	5-PLANT LOCATIONS	PUBLIC WORKS FACILITY	CITY HALL GOUNDS	75TH STREET	TREE FERTILIZATION 75TH STREET	CITY FACILITIES PROGRAM COST	DETENTION AND CULL DE SAC ISLAND FACILITIES
ACRES	2.5	1.7	0.7			4.9	13.7
COST PER ACRE APPLICATION 1	\$ 214.29	\$ 145.71	\$ 60.00	\$ 2,035.69	\$ 1,000.00	\$ 420.00	\$ 1,393.06
COST PER ACRE APPLICATION 2	\$ 260.20	\$ 176.94	\$ 72.86	\$ 2,246.28	\$ -	\$ 510.00	\$ 1,537.17
COST PER ACRE APPLICATION 3	\$ 367.35	\$ 249.80	\$ 102.86	\$ 2,807.85	\$ -	\$ 720.00	\$ 1,921.46
COST PER ACRE APPLICATION 4	\$ 219.39	\$ 149.18	\$ 61.43	\$ 1,895.30	\$ -	\$ 430.00	\$ 1,296.98
COST PER ACRE APPLICATION 5	\$ 219.39	\$ 149.18	\$ 61.43	\$ 1,895.30	\$ -	\$ 430.00	\$ 1,296.98
COST PER ACRE APPLICATION 6	\$ -	\$ -	\$ -	\$ -	\$ -	\$ -	\$ -
TOTAL PROGRAM COST/FACILITY	\$ 1,280.61	\$ 870.82	\$ 358.57	\$ 10,880.43	\$ 1,000.00	\$ 14,390.43	\$ 7,445.65
	\$	\$	\$	\$	\$	\$	\$
		2,151.43				11,880.43	

2015 DETENTION FACILITY FERTILIZATION PROGRAM

DETENTION FACILITY WORKSHEET		
VENDOR	TRU GREEN	UNIT COST PER ACRE
APPLICATION		
Appl #1 March-April	\$ 2,900.00	\$ 101.68
Appl #2 April-May	\$ 3,200.00	\$ 112.20
Appl #3 May-June	\$ 4,000.00	\$ 140.25
Appl #4 July-August	\$ 2,700.00	\$ 94.67
Appl #5 September	\$ 2,700.00	\$ 94.67
Appl #6 Nov-Dec	\$ 1,500.00	\$ 52.59

LOCATION	COST PER ACRE	DALE RD BASIN	NANTUCKET BASIN	WOODLAND BASIN W/WHITTIER	GREENVALLEY BASIN	FAIRVIEW MANNING BASIN	86TH STREET BASIN	PLAINFIELD MANNING BASIN	WESTMINISTER COURT	7702 FLORENCE AREA	TOTALS
ACRES		1.2	2.5	3.1	1.8	1.7	2.1	0.75	0.3	0.25	13.7
COST PER ACRE APPLICATION 1	\$ 101.68	\$ 122.02	\$ 254.21	\$ 315.22	\$ 183.03	\$ 172.86	\$ 213.53	\$ 76.26	\$ 30.50	\$ 25.42	\$ 1,393.06
COST PER ACRE APPLICATION 2	\$ 112.20	\$ 134.64	\$ 280.50	\$ 347.83	\$ 201.96	\$ 190.74	\$ 235.62	\$ 84.15	\$ 33.66	\$ 28.05	\$ 1,537.17
COST PER ACRE APPLICATION 3	\$ 140.25	\$ 168.30	\$ 350.63	\$ 434.78	\$ 252.45	\$ 238.43	\$ 294.53	\$ 105.19	\$ 42.08	\$ 35.06	\$ 1,921.46
COST PER ACRE APPLICATION 4	\$ 94.67	\$ 113.60	\$ 236.68	\$ 293.48	\$ 170.41	\$ 160.94	\$ 198.81	\$ 71.00	\$ 28.40	\$ 23.67	\$ 1,296.98
COST PER ACRE APPLICATION 5	\$ 94.67	\$ 113.60	\$ 236.68	\$ 293.48	\$ 170.41	\$ 160.94	\$ 198.81	\$ 71.00	\$ 28.40	\$ 23.67	\$ 1,296.98
COST PER ACRE APPLICATION 6	\$ 52.59	\$ -	\$ -	\$ -	\$ -	\$ -	\$ -	\$ -	\$ -	\$ -	\$ -
TOTAL PROGRAM COST/FACILITY		\$ 652.17	\$ 1,358.70	\$ 1,684.78	\$ 978.26	\$ 923.91	\$ 1,141.30	\$ 407.61	\$ 163.04	\$ 135.87	\$ 7,445.65

RESOLUTION NO. _____

▲ RESOLUTION AUTHORIZING THE MAYOR TO EXECUTE A CONTRACT FOR THE 2015 LANDSCAPE FERTILIZATION PROGRAM BETWEEN THE CITY OF DARIEN AND TRU GREEN, LP IN AN MOUNT NOT TO EXCEED \$21,836.09

BE IT RESOLVED BY THE CITY COUNCIL OF THE CITY OF DARIEN, DU PAGE COUNTY, ILLINOIS, as follows:

SECTION 1: The City Council of the City of Darien hereby authorizes the Mayor to execute a Contract for the 2015 Fertilization Program between the City of Darien and Tru Green, LP relating to the various fertilizer applications, for the City's 2015 Landscape Fertilization Services at Roadside Rights of Way and Medians of 75th Street, and a certain segment of Plainfield Road and City owned detention facilities. Included also are City owned facilities such as the Water Plant grounds, the Public Works facility and the City Hall grounds, a copy of which is attached hereto as "**Exhibit A**" and is by this reference expressly incorporated herein.

SECTION 2: This Resolution shall be in full force and effect from and after its passage and approval as provided by law.

PASSED BY THE CITY COUNCIL OF THE CITY OF DARIEN, DU PAGE COUNTY, ILLINOIS, this 4th day of May, 2015.

AYES: _____

NAYS: _____

ABSENT: _____

APPROVED BY THE MAYOR OF THE CITY OF DARIEN, DU PAGE COUNTY, ILLINOIS this 4th day of May, 2015.

KATHLEEN MOESLE WEAVER, MAYOR

ATTEST:

JOANNE E. RAGONA, CITY CLERK

APPROVED AS TO FORM:

CITY ATTORNEY

CONTRACT

- 1. This agreement, made and entered into this ____ day of _____ 2013, between the City of Darien, acting by and through its Mayor and Clerk and _____.
- 2. That for and in consideration of the payments and agreements mentioned in City of Darien for the Specifications and contract documents for the 2013 Landscape Fertilization at Roadside Right of ways and Medians and Specified Facilities, along with two optional extensions for 2014 and 2015 and attached hereto, agrees with the City of Darien at his/their own proper cost and expense to furnish the equipment, material, labor, supplies and/or services as provided therein in full compliance with all of the terms of such City of Darien Contract attached hereto.
- 3. It is understood and agreed that City of Darien Contract hereto attached, prepared by the City of Darien, is an essential document of this contract and is a part hereof.
- 4. In witness whereof, the said parties have executed these presents on the date above mentioned.

(City Seal)

CITY OF DARIEN

Attest:

By: _____
City Clerk

By: _____
Mayor

(Corporate Seal)

CORPORATE NAME

Attest:

.

By: _____
Secretary

By: _____
President

(Corporate Seal)

IF A PARTNERSHIP

_____ (Seal)

_____ (Seal)

_____ (Seal)

_____ (Seal)

PARTNERS DOING BUSINESS UNDER THE NAME OF

IF AN INDIVIDUAL

Ray Bell (Seal)

SUBSCRIBED AND SWORN BEFORE ME

This 14 day of

January, 20 13

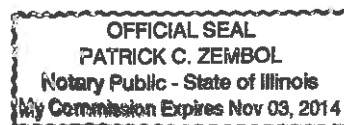

MY COMMISSION EXPIRES: 11-3-14

NOTARY PUBLIC

[Handwritten Signature]

BID PROPOSAL
SCHEDULE OF PRICES
ROADSIDE RIGHT-OF-WAYS AND MEDIANS
AND SPECIFIED FACILITIES
CONTRACT EXTENSION TWO MAY 1, 2015-APRIL 30, 2016

This bid proposal is for a contract extension of one year beginning **May 1, 2015 through April 30, 2016. This contract is for the 2nd extension.** The City shall have the exclusive right to determine which applications shall be used throughout the year. The City also reserves the right to cancel any application as deemed necessary.

I. RIGHT -OF-WAY MAINTENANCE FERTILIZATION

<u>FERTILIZATION DESCRIPTION</u>	<u>COST</u>
APPLICATION #1 MARCH – APRIL Fertilizer application with Crabgrass Pre-emergent 19-3-7, Plus0.86% Pre-M	<u>\$ 2900.00</u>
APPLICATION #2 APRIL – MAY Fertilizer application with Crabgrass Booster Pre-emergent, Broadleaf Weed Control. Formolene 30-0-0, Urea 45-0-0, Potassium Chloride 0-0-62, Broadleaf Weed Control, Trimec 899, Pre-M 6WP	<u>\$ 3200.00</u>
APPLICATION #3 MAY – JUNE Fertilizer application with Broadleaf Weed Control and Grub Control. Formolene 30-0-0, Urea 45-0-0, Potassium Chloride 0-0-62, Broadleaf Weed Control Trimec 899, Merit 75 WSP	<u>\$ 4000.00</u>
APPLICATION #4 JULY – AUGUST Fertilizer application with Broadleaf Weed Control. Formolene 30-0-0, Potassium Chloride 0-0-62, Broadleaf Weed Control Trimec 899	<u>\$ 2700.00</u>
APPLICATION #5 SEPTEMBER Fertilizer application with Broadleaf Weed Control. Follow up Grub Control as needed. 14-3-6 with 1% Iron, Trimec 899, Dylox 80 Insecticide	<u>\$ 2700.00</u>
APPLICATION #6 NOVEMBER - DECEMBER Dormant Fertilizer application. Urea 45-0-0	<u>\$ 1500.00</u>
SUB TOTAL	<u>\$ 17,000.00</u>

II. SPECIFIED FACILITY MAINTENANCE

<u>FERTILIZATION DESCRIPTION</u>	<u>COST</u>
APPLICATION #1 MARCH – APRIL Fertilizer application with Crabgrass Pre-emergent 19-3-7, Plus0.86% Pre-M	\$ <u>420.00</u>
APPLICATION #2 APRIL – MAY Fertilizer application with Crabgrass Booster Pre-emergent, Broadleaf Weed Control. Formolene 30-0-0, Urea 45-0-0, Potassium Chloride 0-0-62, Broadleaf Weed Control, Trimec 899, Pre-M 6WP	\$ <u>510.00</u>
APPLICATION #3 MAY – JUNE Fertilizer application with Broadleaf Weed Control and Grub Control. Formolene 30-0-0, Urea 45-0-0, Potassium Chloride 0-0-62, Broadleaf Weed Control Trimec 899, Merit 75 WSP	\$ <u>720.00</u>
APPLICATION #4 JULY – AUGUST Fertilizer application with Broadleaf Weed Control. Formolene 30-0-0, Potassium Chloride 0-0-62, Broadleaf Weed Control Trimec 899	\$ <u>430.00</u>
APPLICATION #5 SEPTEMBER Fertilizer application with Broadleaf Weed Control. Follow up Grub Control as needed. 14-3-6 with 1% Iron, Trimec 899, Dylox 80 Insecticide	\$ <u>430.00</u>
APPLICATION #6 NOVEMBER - DECEMBER Dormant Fertilizer application. Urea 45-0-0	\$ <u>230.00</u>
SUB TOTAL	\$ <u>2740.00</u>
III TREE FERTILIZATION Tree Root Feeding for trees	\$ <u>1200.00</u>
TOTAL COST SECTION I & II & III for 2015	\$ <u>20,940.00</u>

AGENDA MEMO
Municipal Services Committee
April 27, 2015

ISSUE STATEMENT

Approving an ordinance ascertaining the prevailing rate of wages for laborers, workman, and mechanics employed on Public Works projects for the City of Darien, County of DuPage, Illinois.

BACKGROUND/HISTORY

Annually, the state law requires that municipalities ascertain the prevailing wages to be paid on Public Works projects within the community. The State of Illinois provides the last listing of the prevailing rates and it then becomes the City's responsibility to accept and publish these rates for future construction projects of the City. An ordinance has been developed, as in past years, to certify the prevailing wage rates for the coming year that has been received from the Illinois Department of Labor which is dated April 2015.

STAFF RECOMMENDATION

The State requires the annual approval of the prevailing wage rates as published by the State of Illinois and, as such, staff recommends acceptance of these rates.

ALTERNATE CONSIDERATION

Not approving the ordinance at this time.

DECISION MODE

This item will be placed on the May 4, 2015 agenda for formal City Council consideration and approval

**CITY OF DARIEN
DU PAGE COUNTY, ILLINOIS**

ORDINANCE NO. _____

**AN ORDINANCE OF THE CITY OF DARIEN,
DU PAGE COUNTY, ILLINOIS, ASCERTAINING
THE PREVAILING RATE OF WAGES FOR
LABORERS, WORKMEN, AND MECHANICS
EMPLOYED ON PUBLIC WORKS OF SAID CITY**

**ADOPTED BY THE
MAYOR AND CITY COUNCIL
OF THE
CITY OF DARIEN**

THIS 4th DAY OF MAY, 2015

**Published in pamphlet form by authority
of the Mayor and City Council of the City
of Darien, DuPage County, Illinois, this ___
___ day of May, 2015.**

ORDINANCE NO. _____

**AN ORDINANCE OF THE CITY OF DARIEN, DU PAGE COUNTY, ILLINOIS,
ASCERTAINING THE PREVAILING RATE OF WAGES FOR
LABORERS, WORKMEN, AND MECHANICS
EMPLOYED ON PUBLIC WORKS OF SAID CITY**

WHEREAS, The State of Illinois has enacted “An act regulating wages of laborers, mechanics and other workers employed in any public works by the State, County, City, or any public body or any political subdivision or by anyone under contract for public works,” approved June 26, 1941, codified as amended, 820 ILCS 130/1 et seq. (1993), formally Ill. Rev. Stat., Ch. 48, par. 39s-1 et seq.; and,

WHEREAS, the aforesaid Act requires that the City Council of the City of Darien investigate and ascertain the prevailing rate of wages as defined in said Act for laborers, mechanics and other workers in the locality of said City of Darien employed in performing construction of public works, for said City of Darien;

NOW, THEREFORE, BE IT ORDAINED BY THE CITY COUNCIL OF THE CITY OF DARIEN, DU PAGE COUNTY, ILLINOIS, as follows:

SECTION 1: To the extent and as required by “An act regulating wages of laborers, mechanics and other workers employed in any public works by the State, County, City, or any public body or any political subdivision or by anyone under contract for public works,” approved June 26, 1941, as amended, the general prevailing rate of wages in this locality for laborers, mechanics and other workers engaged in construction of public works coming under the jurisdiction of the City of Darien is hereby ascertained to be the same as the prevailing rate of wages for construction work in DuPage County area as determined by the Department of Labor of

ORDINANCE NO. _____

the State of Illinois effective May 2015, a copy of that determination being attached hereto and incorporated herein by reference. As required by said Act, any and all revisions of the prevailing rate of wages by the Department of Labor of the State of Illinois shall supersede the Department's April determination and apply to any and all public works construction undertaken by the City of Darien. The definition of any terms appearing in this Ordinance which are also used in aforesaid Act shall be the same as in said Act.

SECTION 2: Nothing herein contained shall be construed to apply said general prevailing rate of wages as herein ascertained to any work or employment except public works construction of the City of Darien to the extent required by the aforesaid Act.

SECTION 3: The City Clerk shall publicly post or keep available for inspection by any interested party in the main office of the City this determination of prevailing rate of wages then in effect shall be attached to all contract specification.

SECTION 4: The City Clerk shall mail a copy of this determination to any employer, and to any association of employers and to any person or association of employees who have filed their names and addresses, requesting copies of any determination stating the particular rates and the particular class of workers whose wages will be affected by such rates.

SECTION 5: The City Clerk shall promptly file a certified copy of this Ordinance with both the Secretary of State Index Division and the Department of Labor of the State of Illinois.

SECTION 6: The City Clerk shall cause to be published, in a newspaper of general circulation within the area, a copy of this Ordinance, and such publication shall constitute notice that the determination is effective and that this is the determination of this public body.

ORDINANCE NO. _____

SECTION 7: This Ordinance shall be in full force and effect from and after its passage and approval as provided by law.

PASSED BY THE CITY COUNCIL OF THE CITY OF DARIEN, DU PAGE COUNTY, ILLINOIS, this 4th day of May, 2015.

AYES: _____

NAYS: _____

ABSENT: _____

APPROVED BY THE MAYOR OF THE CITY OF DARIEN, DU PAGE COUNTY, ILLINOIS, this 4th day of May, 2015.

KATHLEEN MOESLE WEAVER, MAYOR

ATTEST:

JOANNE E. RAGONA, CITY CLERK

APPROVED AS TO FORM:

CITY ATTORNEY

AGENDA MEMO
Municipal Services Committee
April 27, 2015

ISSUE STATEMENT

A resolution authorizing the purchase of one (1) new 2015 Ford Expedition Carryall Unit from Landmark Ford in the amount of \$29,941.

BACKGROUND/HISTORY

The proposed vehicle is to be utilized by the Director of Municipal Services and is replacing Unit B-4, a 1997 Lexus sedan. The vehicle has 107,000 miles and was a police seizure. The vehicle is beginning to have electrical problems, exterior rusting and paint peeling. Unit B-4 was budgeted for replacement and the vehicle rating report is attached and labeled as Attachment 1. Please recall the Vehicle Replacement Policy calls out for vehicles to be replaced at a rating of 75 or above.

Staff has selected Landmark Ford for the awarded vendor as Landmark Ford is the awarded vendor for the Northwest Municipal Conference Joint Cooperative Purchasing for fleet sales to municipalities within the Midwest. Attached and labeled as Exhibit A, is the cost breakdown for the 2015 Ford Expedition Carryall Unit.

Please note the cutoff date for this vehicle is May 1, 2015. In order to satisfy the cutoff date Staff will place an order for the vehicle on May 1, 2015 and pending City Council approval on May 4, 2015 will have the ability to cancel the purchase if required. See e-mail correspondence labeled as Attachment 2.

The proposed expenditure would be expended from the following line account:

ACCOUNT NUMBER	ACCOUNT DESCRIPTION	FY 15/16 BUDGET	PROPOSED EXPENDITURE	PROPOSED BALANCE
01-30-4815	CAPITAL PURCHASES TRUCK REPL UNIT B-4	\$ 31,708.00	\$ 29,941.00	\$ 1,767.00

STAFF/COMMITTEE RECOMMENDATION

Staff recommends approval of the resolution authorizing the purchase one new 2015 Ford Expedition Carryall Unit from Landmark Ford in the amount of \$29,941.

ALTERNATE DECISION

As recommended by the Committee.

DECISION MODE

This item will be on the May 4, 2015 City Council agenda for formal consideration.

CRITERIA FOR REPLACING CITY VEHICLES AND EQUIPMENT				
UNIT NO	B4	DEPARTMENT	Admin.	DATE
MODEL YEAR	1997	MODEL	Lexus	11-2-14
CURRENT MILEAGE	100,358	CURRENT HOURS		
			MAXIMUM POINTS	VEHICLE SCORE
AGE				
	Department	Admin.		
	Life Expectancy	10 years		
	Age as of Report Date	17		
	AGE: Meets Requirements	yes	20	20
USAGE				
	MILES	100,358		
	HOURS			
	ATTACHMENT C OF THE VEHICLE REPLACEMENT POLICY			
	USAGE: Meets Requirements		20	20
TYPE OF SERVICE				
	I-LIGHT DUTY			
	IO-CRITICAL DUTY			
	SERVICE: Meets Requirements		15	8
RELIABILITY				
	RELIABILITY: Frequency or Visits for Service			
	RELIABILITY: Meets Requirements		15	3
MAINTENANCE AND REPAIR COSTS				
	REPAIRS: Cost per Mile/Hours Exceeds Vehicle in Class			
	ORIGINAL PURCHASE PRICE	seizure		
	LIFE TO DATE REPAIR COST	1,871.66		
	PERCENTAGE OF REPAIRS TO PURCHASE PRICE	100%		

UNIT NO	B4	DEPARTMENT	Admin.	DATE
MODEL YEAR	1997	MODEL	Lexus	11-2-14
CURRENT MILEAGE	100,358	CURRENT HOURS		
			MAXIMUM POINTS	VEHICLE SCORE
PERCENTAGES OF REPAIR POINTS	POINTS			
1 THROUGH 20	2			
21 THROUGH 40	4			
41 THROUGH 60	6			
61 THROUGH 80	8			
81 THROUGH 100	10			
	REPAIRS: Meets Requirements		10	10
CONDITION				
	CONDITION OF ENGINE COMPONENTS (MAJOR REPAIRS NEEDED OR ANTICIPATED), BODY (BODY SHEET METAL RUSTED, STRUCTURAL COMPONENTS)			
	CONDITION: Meets Requirements		15	10
TECHNOLOGICAL ADVANCEMENTS	FUEL EMISSIONS, SAFETY FEATURES, ERGONOMICS		5	5
TOTAL POINTS			100	76

CITY OF DARIEN
 Repair Transaction Cost Detail

Equipment#	Repair Order#	Date	Meter(1)	Shop Loc/ Rep Class	Rep Reason/ Rep Site			
						<u>Part(\$)</u>	<u>Labor(\$)</u>	<u>Hours</u>
B4	0000028424	07/01/09	112330	/01	08/01			
<u>Group-System</u>				<u>Mech/Vendor</u>	<u>Work Acc</u>			
	06-35 - BATTERY			002		99.99	7.50	0.50
B4	0000028549	10/08/09	59955	/01	08/01			
	01-PMA - PREV. MAINT.			001		12.50	14.00	0.50
	07-41 - AIR INTAKE SYS			001		15.71	14.00	0.50
B4	0000028756	03/09/10	63791	01/01	08/01			
	01-PMA - PREV. MAINT.			002		12.50	15.00	1.00
B4	0000028928	08/06/10	67470	01/01	08/01			
	01-PMA - PREV. MAINT.			001		12.50	28.00	1.00
	03-01 - A/C			001		259.35	112.00	4.00
B4	0000029145	02/15/11	71750	01/01	08/01			
	07-48 - EMISSION CONTRL			001		320.00	112.00	4.00
	07-41 - AIR INTAKE SYS			001		14.80	0.00	0.00
	01-PMA - PREV. MAINT.			001		12.50	0.00	0.00
	03-10 - WIPERS/WASHERS			001		24.85	0.00	0.00
	04-13 - BRAKES			001		45.97	0.00	0.00
B4	0000029497	11/23/11	78480	01/01	08/01			
	01-PMA - PREV. MAINT.			002		14.47	15.00	1.00
	07-41 - AIR INTAKE SYS			002		24.00	3.75	0.25
	04-18 - HUB/BEARNG/SEAL			002		5.47	3.75	0.25
	01-PMB - PREV. MAINT.			002		24.00	15.00	1.00
	01-PMC - PREV. MAINT.			002		42.62	22.50	1.50
B4	0000029510	12/22/11	78640	01/02	01/01			
	06-34 - LIGHTING SYS			002		2.00	7.50	0.50
B4	0000029723	04/30/12	82764	01/01	08/01			
	01-PMA - PREV. MAINT.			002		12.83	30.00	2.00
	04-16 - SUSPENSION			002		76.52	15.00	1.00
B4	0000029790	06/20/12	84660	01/03	01/01			
	06-35 - BATTERY			002		116.00	15.00	1.00
B4	0000029926	10/11/12	86734	01/01	08/01			
	01-PMA - PREV. MAINT.			002		25.60	7.50	0.50
	06-32 - CRANKING SYS			002		140.12	15.00	1.00
	06-33 - IGNITION SYS			002		9.68	3.75	0.25
B4	0000030112	04/08/13	90129	01/01	08/01			
	01-PMA - PREV. MAINT.			002		25.30	7.50	0.50
	04-16 - SUSPENSION			002		354.58	30.00	2.00
	02-17 - TIRES,TUBES,ETC			002		301.12	22.50	1.50
B4	0000030581	07/10/14	100358	01/01	08/01			
	01-PMB - PREV. MAINT.			002		259.33	30.00	2.00
	01-PMA - PREV. MAINT.			002		25.60	0.00	0.00
	01-PMC - PREV. MAINT.			002		21.00	7.50	0.50
	01-PME - PREV. MAINT.			002		0.00	3.75	0.25
	06-33 - IGNITION SYS			002		61.50	3.75	0.25
<u>Grand Total</u>						<u>2,372.41</u>	<u>581.25</u>	<u>28.75</u>

CITY OF DARIEN
 Equipment Cost Detail - Curr/YTD/LTD/Last Year
 January 2015

Equipment#	Asset#	Serv Inc	License	Miscellaneous Id	Fleet	Class	Cost Ctr	Profit Ctr	EqUserDef
		B4		DAN G	020	02			
Active									
Purchase Price(\$): 19,882				Salvage Value(\$): 0			Book Value(\$): 19,882		
		<u>Current Period</u>		<u>Year-To-Date</u>		<u>Life-To-Date</u>		<u>Last Year</u>	
Miles(1):		0		5,668		53,566		15,425	
<u>Repair Detail</u>	<u>Cost\$</u>	<u>\$/Miles(1)</u>	<u>Cost\$</u>	<u>\$/Miles(1)</u>	<u>Cost\$</u>	<u>\$/Miles(1)</u>	<u>Cost\$</u>	<u>\$/Miles(1)</u>	
Non Maintenance	0.00	0.00	0.00	0.00	0.00	0.00	0.00	0.00	0.00
PREV. MAINT.	0.00	0.00	347.18	0.06	696.50	0.01	32.80	0.00	0.00
TIRES	0.00	0.00	0.00	0.00	323.62	0.01	323.62	0.02	0.02
BODY & CAB	0.00	0.00	0.00	0.00	396.20	0.01	0.00	0.00	0.00
CHASSIS	0.00	0.00	0.00	0.00	531.29	0.01	384.58	0.02	0.02
ELECTRICAL	0.00	0.00	65.25	0.01	481.79	0.01	0.00	0.00	0.00
ENGINE/MOTOR	0.00	0.00	0.00	0.00	504.26	0.01	0.00	0.00	0.00
Repair Total	0.00	0.00	412.43	0.07	2,933.66	0.05	741.00	0.05	
<u>Total Costs</u>									
RGUNL(1)	0.00	0.00	383.00	0.07	5,773.90	0.11	842.30	0.05	
Shop Parts	0.00	0.00	367.43	0.06	2,372.41	0.04	681.00	0.04	
Shop Labor	0.00	0.00	45.00	0.01	561.25	0.01	60.00	0.00	
Outside Parts	0.00	0.00	0.00	0.00	0.00	0.00	0.00	0.00	
Outside Labor	0.00	0.00	0.00	0.00	0.00	0.00	0.00	0.00	
T	0.00	0.00	795.43	0.14	8,707.56	0.16	1,583.30	0.10	

CITY OF DARIEN
 Equipment Cost Detail - Curr/YTD/LTD/Last Year
 January 2015

Report - E1220

Equipment#	Asset#	Service Inc	License	Miscellaneous Id	Fleet	Class	Cost Ctr	Profit Ctr	EqUserDef
Grand Totals									
		Active: 1	Inactive: 0	Down: 0	Deleted: 0				
		<u>Current Period</u>		<u>Year-To-Date</u>		<u>Life-To-Date</u>		<u>Last Year</u>	
Usage(1)-Primary:		0		5,668		53,568		15,425	
Usage(2)-Second:		0		0		0		0	
Usage(3)-Third:		0		0		0		0	
Repair Detail		<u>\$/Usage(1)</u>		<u>\$/Usage(1)</u>		<u>\$/Usage(1)</u>		<u>\$/Usage(1)</u>	
Non Maintenance	0.00	0.00	0.00	0.00	0.00	0.00	0.00	0.00	0.00
PREV. MAINT.	0.00	0.00	347.18	0.06	698.50	0.01	32.80	0.00	0.00
TIRES	0.00	0.00	0.00	0.00	323.62	0.01	323.62	0.02	0.00
BODY & CAB	0.00	0.00	0.00	0.00	396.20	0.01	0.00	0.00	0.00
CHASSIS	0.00	0.00	0.00	0.00	531.29	0.01	384.58	0.02	0.00
DRIVE TRAIN	0.00	0.00	0.00	0.00	0.00	0.00	0.00	0.00	0.00
ELECTRICAL	0.00	0.00	65.25	0.01	481.79	0.01	0.00	0.00	0.00
ENGINE/MOTOR	0.00	0.00	0.00	0.00	504.28	0.01	0.00	0.00	0.00
ACCESSORIES	0.00	0.00	0.00	0.00	0.00	0.00	0.00	0.00	0.00
SPECIAL APPLICS	0.00	0.00	0.00	0.00	0.00	0.00	0.00	0.00	0.00
BUCKETS/BOOMS	0.00	0.00	0.00	0.00	0.00	0.00	0.00	0.00	0.00
MISC SMALL EQP	0.00	0.00	0.00	0.00	0.00	0.00	0.00	0.00	0.00
EDGERS	0.00	0.00	0.00	0.00	0.00	0.00	0.00	0.00	0.00
Repair Total	0.00	0.00	412.43	0.07	2,933.66	0.05	741.00	0.05	
Total Cost									
Fuel(1)-Primary	0.00	0.00	383.00	0.07	5,773.90	0.11	842.30	0.05	
Fuel(2)-Alternate	0.00	0.00	0.00	0.00	0.00	0.00	0.00	0.00	
Fuel(3)-Auxiliary	0.00	0.00	0.00	0.00	0.00	0.00	0.00	0.00	
Fluid(1)	0.00	0.00	0.00	0.00	0.00	0.00	0.00	0.00	
Fluid(2)	0.00	0.00	0.00	0.00	0.00	0.00	0.00	0.00	
Fluid(3)	0.00	0.00	0.00	0.00	0.00	0.00	0.00	0.00	
Fluid(4)	0.00	0.00	0.00	0.00	0.00	0.00	0.00	0.00	
Fluid(5)	0.00	0.00	0.00	0.00	0.00	0.00	0.00	0.00	
Fluid(6)	0.00	0.00	0.00	0.00	0.00	0.00	0.00	0.00	
Shop Parts	0.00	0.00	367.43	0.06	2,372.41	0.04	681.00	0.04	
Shop Labor	0.00	0.00	45.00	0.01	561.25	0.01	60.00	0.00	
Outside Parts	0.00	0.00	0.00	0.00	0.00	0.00	0.00	0.00	
Outside Labor	0.00	0.00	0.00	0.00	0.00	0.00	0.00	0.00	
Depreciation	0.00	0.00	0.00	0.00	0.00	0.00	0.00	0.00	
License	0.00	0.00	0.00	0.00	0.00	0.00	0.00	0.00	
Insurance	0.00	0.00	0.00	0.00	0.00	0.00	0.00	0.00	
Other Fixed	0.00	0.00	0.00	0.00	0.00	0.00	0.00	0.00	
Grand Total	0.00	0.00	795.43	0.14	8,707.56	0.16	1,583.30	0.10	

From: [Dan Gombac](#)
To: [Maria Gonzalez](#)
Subject: FW: Ford Expedition Cutoff
Date: Monday, April 13, 2015 10:19:57 AM

Maria:

Please use this e-mail as Att 3

Daniel Gombac
Director of Municipal Services
630-353-8106

To receive important information from the City of Darien sign up for our electronic newsletter:

DARIEN DIRECT CONNECT

Follow the link below and subscribing is simple!

<http://www.darien.il.us/Departments/Administration/CityNews.html>

From: Lyle Snow [mailto:lylesnow@msn.com]
Sent: Monday, April 13, 2015 10:17 AM
To: Dan Gombac
Subject: RE: Ford Expedition Cutoff

Dan:

We can order your Expedition on May 1st in the morning and we can cancel it on Monday if they don't approve the purchase.

Lyle Snow
Cell 217 553 2508
Fax 217 862 5316

From: dgombac@darienil.gov
To: lylesnow@msn.com
CC: bvana@darienil.gov; pnosek@darienil.gov
Date: Fri, 10 Apr 2015 09:29:17 -0500
Subject: RE: Ford Expedition Cutoff

Good morning Lyle:

As per our conversation this morning,, it is our understanding that the cutoff date for the Ford Expedition is May 1. Our Municipal Services Committee will be reviewing the agenda item for the purchase of an Expedition and forwarding a recommendation to the City Council on May 4, 2015.

It is our understanding that we would be able to order the truck by no later than May 1, 2015 11:00am and should the vehicle not be approved by the City Council on May 4th, we would cancel the order that evening. Please confirm our understanding.

Thank you for your assistance.

Sincerely,

Daniel Gombac
Director of Municipal Services
630-353-8106

To receive important information from the City of Darien sign up for our

electronic newsletter:

DARIEN DIRECT CONNECT

Follow the link below and subscribing is simple!

<http://www.darien.il.us/Departments/Administration/CityNews.html>

From: Dan Gombac
Sent: Thursday, April 09, 2015 4:38 PM
To: 'lylesnow@msn.com'
Subject: Ford Expedition Cutoff

Lyle:

We are requesting City Council approval for the 2015 Expedition through the State contract. Will we be ok if we place order on May 5??

Daniel Gombac
Director of Municipal Services
630-353-8106

To receive important information from the City of Darien sign up for our
electronic newsletter:

DARIEN DIRECT CONNECT

Follow the link below and subscribing is simple!

<http://www.darien.il.us/Departments/Administration/CityNews.html>

RESOLUTION NO. _____

A RESOLUTION AUTHORIZING THE PURCHASE OF ONE (1) NEW 2015 FORD EXPEDITION CARRYALL UNIT FROM LANDMARK FORD IN THE AMOUNT OF \$29,941.00

BE IT RESOLVED BY THE CITY COUNCIL OF THE CITY OF DARIEN, DU PAGE COUNTY, ILLINOIS, as follows:

SECTION 1: The City Council of the City of Darien does hereby authorize the purchase of one (1) new 2015 Ford Expedition Carryall Unit from Landmark Ford in the amount of \$29,941.00, a copy of which is attached hereto as "Exhibit A" and is by this reference expressly incorporated herein.

SECTION 2: This Resolution shall be in full force and effect from and after its passage and approval as provided by law.

PASSED BY THE CITY COUNCIL OF THE CITY OF DARIEN, DU PAGE COUNTY, ILLINOIS, this 4th day of May, 2015.

AYES: _____

NAYS: _____

ABSENT: _____

APPROVED BY THE MAYOR OF THE CITY OF DARIEN, DU PAGE COUNTY, ILLINOIS, this 4th day of May, 2015.

KATHLEEN MOESLE WEAVER, MAYOR

ATTEST:

JOANNE E. RAGONA, CITY CLERK

APPROVED AS TO FORM:

CITY ATTORNEY



SPC WINNER
NORTH WEST MUNICIPAL CONFERENCE
2015 FORD EXPEDITION 4 DOOR
4X4 SPECIAL SERVICE PACKAGE
Call LYLE SNOW (800) 798-9912
Email lylesnow@msn.com

27,188.00 +
 78.00 +
 386.00 +
 200.00 +
 120.00 +
 289.00 +
 564.00 +
 430.00 +
 621.00 +
 20.00 +
 45.00 +
 29,941.00 * +

STANDARD PACKAGE \$27,188.00

3.5L V6 EcoBoost
 6 Speed automatic transmission
 Brakes 4-wheel disc (ABS)
 Brake assistance
 Traction control
 P265/70R17 OWL on/off road
 Advance trac w/roll stability control
 Air Conditioning
 AM/FM Radio
 Rear child safety locks
 Dual power heated mirrors
 Trailer tow-integrated class IV
 w/4 pin connector
 3.73 Axle ratio
 Column Shifter
 Floor console delete
 Fog lamps
 Solar tinted glass
 Privacy glass rear
 Power points (1) front (1) rear
 Rear window defroster

Intermittent wipers front & rear
 Dual stage front air bags
 Air bags Safety canopy side impact
 Tilt steering wheel
 Power windows driver one touch
 up/down
 Front seats cloth
 Rear seat vinyl 40-20-40 folding
 Vinyl floor covering
 Door handles mold-in-color
 Black Grille
 Tire pressure monitoring system
 Securilock passive anti-theft system
 Steering-variable-assist power
 Suspension-multilink independent rear
 Keyless-entry remote
 Securicode (keypad)
 Cruise control
 Easy fuel (capless refueling)

"WE WILL GIVE TOP DOLLAR FOR YOUR USED VEHICLES"

ORDER CUT OFF DATE MAY 1, 2015

ADDITIONAL OPTIONS AND ORDER FORM

PLEASE ENTER THE FOLLOWING

FORD FLEET NUMBER QD578

CONTACT NAME Dan Gombac

PHONE NUMBER 630-353-8106

PURCHASE ORDER NUMBER 050415 City Council Resolution

STATE TAX EXEMPT NUMBER E9997-4487-07

<p><i>Quantity</i></p> <p style="font-size: 24px; margin: 0;">1</p>

Check desired options

Check desired options

<input checked="" type="checkbox"/>	All-weather floor mats		78.00	<input checked="" type="checkbox"/>	Running Boards	186	430.00
<input checked="" type="checkbox"/>	* Fleet convenience package	50F	386.00	<input type="checkbox"/>	EL model extended length		2785.00
<input checked="" type="checkbox"/>	Delivery beyond 30 miles		200.00	<input type="checkbox"/>	2 Wheel drive		(2252.00)
<input checked="" type="checkbox"/>	Cloth 2 nd row seat	21F	120.00	<input type="checkbox"/>	6" Drivers side spotlight		339.00
<input type="checkbox"/>	Vinyl 3 rd row seat	875	847.00	<input type="checkbox"/>	Engine Block Heater	41H	35.00
<input type="checkbox"/>	Cloth 3 rd row seat	875	847.00	<input checked="" type="checkbox"/>	4 Corner strobe lights led		621.00
<input checked="" type="checkbox"/>	Rustproof & undercoating		289.00	<input type="checkbox"/>	Passenger side spotlight		339.00
<input type="checkbox"/>	16" black push bumper		562.00	<input checked="" type="checkbox"/>	Extra key no remote		20.00
<input checked="" type="checkbox"/>	Power code remote start		564.00	<input type="checkbox"/>	CD Rom service manual		245.00
<input type="checkbox"/>	Exterior Colors			<input type="checkbox"/>	Heavy Duty Trailer Tow	536	489.00
<input type="checkbox"/>	Magnetic Metallic	J7	N/C	<input checked="" type="checkbox"/>	Day time running lights	43D	45.00
<input type="checkbox"/>	Oxford White	Z1	N/C	<input type="checkbox"/>	XLT Package 200A		6472.00
<input checked="" type="checkbox"/>	Ingot Silver	UX		<input type="checkbox"/>	XLT Package 201A		10,261.00
<input type="checkbox"/>	Vermillion Red	F1	N/C				
<input type="checkbox"/>	Blue Jeans Metallic	N1	N/C				
<input type="checkbox"/>	Tuxedo Black Metallic	UH	N/C				
<input type="checkbox"/>	Bronze Fire Metallic	H7	N/C				
<input type="checkbox"/>	Green Gem Metallic	JW	N/C				
<input type="checkbox"/>	Interior Dune	CD	N/C				
<input checked="" type="checkbox"/>	Interior Ebony	CH	N/C				

***Includes Power adjustable pedals, Reverse sensing system, & Message center.**

CALL ABOUT MUNICIPAL FINANCING

Payment Required At Time Of Delivery

AGENDA MEMO
Municipal Services Committee
April 27, 2015

ISSUE STATEMENT

A **resolution** authorizing the purchase of one new 2015 Ford F-150 Crew Cab 2WD pick-up truck from Roesch Ford in the amount of \$22,301.

BACKGROUND/HISTORY

The proposed truck is to be utilized primarily to support the Street Division during the concrete program, (March-October) and utilized by staff through the remaining months. The vehicle would replace a retired 2003 Ford Expedition, Police Department vehicle. We are looking to replace the Ford Expedition with a Ford F-150 pick-up truck with an extended cab. The truck would also allow the staff to transport informational project signs that are needed for the program and be equipped with various tools necessary to complete various tasks. The vehicle would also be equipped with a printer for printing concrete estimates for residents. In addition, the change from a sport utility vehicle to a pick-up truck would provide more functionality for departmental jobs throughout the year.

The proposed vehicle would be replacing unit 120, a 2003 Ford Expedition with a 165,000 miles. The vehicle also has ongoing mechanical problems, including severe exterior rusting. Unit 120 was budgeted for replacement and the vehicle rating report is attached and labeled as **Attachment 1**. Please recall the Vehicle Replacement Policy calls out for vehicles to be replaced at a rating of 75 or above.

Staff has selected Roesch Ford Commercial Truck Center and is the awarded vendor for the Northwest Municipal Conference Joint Cooperative for fleet sales to municipalities within the Midwest. Attached and labeled as **Exhibit A**, is the cost breakdown for the 2015 Ford F-150 pick-up truck.

The proposed expenditure would be expended from the following line account:

ACCOUNT NUMBER	ACCOUNT DESCRIPTION	FY 15/16 BUDGET	PROPOSED EXPENDITURE	PROPOSED BALANCE
01-30-4815	CAPITAL PURCHASES TRUCK REPL UNIT 120	\$23,349	\$22,301	\$1,048
01-30-4815	CAPITAL PURCHASES TRUCK DECALS- LIGHTING	N/A	\$ 1,048	-0-

STAFF RECOMMENDATION

Staff recommends approval of the resolution authorizing the purchase of one new 2015 Ford F-150 Crew Cab 2WD pick-up truck from Roesch Ford in the amount of \$22,301.

2015 Ford F-150 Truck
April 27, 2015
Page 2

ALTERNATE DECISION

As recommended by the Committee.

DECISION MODE

This item will be on the May 4, 2015 City Council agenda for formal consideration.

CRITERIA FOR REPLACING CITY VEHICLES AND EQUIPMENT				
UNIT NO	AL 120	DEPARTMENT	Admin.	DATE
MODEL YEAR	2003	MODEL	Expedition	9-21-13
CURRENT MILEAGE	146,816.7	CURRENT HOURS		
			MAXIMUM POINTS	VEHICLE SCORE
AGE				
	Department	Admin.		
	Life Expectancy	10 years		
	Age as of Report Date	10		
	AGE: Meets Requirements	yes	20	20
USAGE				
	MILES	146,816.7		
	HOURS			
	ATTACHMENT C OF THE VEHICLE REPLACEMENT POLICY			
	USAGE: Meets Requirements		20	20
TYPE OF SERVICE				
	1-LIGHT DUTY			
	10-CRITICAL DUTY			
	SERVICE: Meets Requirements		15	8
RELIABILITY				
	RELIABILITY: Frequency or Visits for Service			
	RELIABILITY: Meets Requirements		15	3
MAINTENANCE AND REPAIR COSTS				
	REPAIRS: Cost per Mile/Hours Exceeds Vehicle in Class			
	ORIGINAL PURCHASE PRICE	From AD		
	LIFE TO DATE REPAIR COST	7,283.29		
	PERCENTAGE OF REPAIRS TO PURCHASE PRICE	100%		

UNIT NO	A1	DEPARTMENT	Asst. Mgr.	DATE	
MODEL YEAR	2003	MODEL	Expedition		9-21-13
CURRENT MILEAGE	146,067	CURRENT HOURS			
			MAXIMUM POINTS	VEHICLE SCORE	
PERCENTAGES OF REPAIR POINTS	POINTS				
1 THROUGH 20	2				
21 THROUGH 40	4				
41 THROUGH 60	6				
61 THROUGH 80	8				
81 THROUGH 100	10				
	REPAIRS: Meets Requirements		10		10
CONDITION:					
	CONDITION OF ENGINE COMPONENTS (MAJOR REPAIRS NEEDED OR ANTICIPATED), BODY (BODY SHEET METAL RUSTED, STRUCTURAL COMPONENTS)				
	CONDITION: Meets Requirements		15		13
TECHNOLOGICAL ADVANCEMENTS	FUEL EMISSIONS, SAFETY FEATURES, ERGONOMICS		5		5
TOTAL POINTS			100		79

CITY OF DARIEN
 Repair Transaction Cost Detail

Equipment#	Repair Order#	Date	Meter(1)	Shop Loc/ Rep Class	Rep Reason/ Rep Site			
						<u>Part(\$)</u>	<u>Labor(\$)</u>	<u>Hours</u>
A1	0000025334	12/22/03	3360	/01	08/01			
<u>Group-System</u>				<u>Mech/Vendor</u>	<u>Work Acc</u>			
	01-PMA - PREV. MAINT.			001		8.60	14.00	0.50
A1	0000025424	03/16/04	8270	/01	08/01			
	01-PMA - PREV. MAINT.			001		8.60	14.00	0.50
A1	0000025523	06/09/04	13600	/01	08/01			
	01-PMA - PREV. MAINT.			001		8.60	14.00	0.50
	01-PMC - PREV. MAINT.			001		24.45	28.00	1.00
A1	0000025602	08/10/04	17925	01/01	08/01			
	01-PMA - PREV. MAINT.			001		9.60	14.00	0.50
	01-PMB - PREV. MAINT.			001		0.00	28.00	1.00
A1	0000025723	11/09/04	23180	01/01	08/01			
	01-PMA - PREV. MAINT.			001		8.60	14.00	0.50
A1	0000025782	01/11/05	26125	01/01	08/01			
	01-PMA - PREV. MAINT.			001		10.98	14.00	0.50
	01-PMC - PREV. MAINT.			001		19.96	28.00	1.00
A1	0000025832	02/11/05	27773	01/01	08/01			
	01-PMB - PREV. MAINT.			001		125.80	84.00	3.00
A1	0000025954	06/03/05	31740	/01	08/01			
	01-PMA - PREV. MAINT.			001		11.01	14.00	0.50
A1	0000026025	08/03/05	35390	/01	08/01			
	01-PMA - PREV. MAINT.			001		11.01	28.00	1.00
A1	0000026060	09/07/05	37370	/01	08/01			
	02-17 - TIRES,TUBES,ETC			001		16.00	28.00	1.00
A1	0000026121	10/18/05	39500	/01	08/01			
	01-PMA - PREV. MAINT.			001		11.01	14.00	0.50
A1	0000026164	11/11/05	41300	/01	01/01			
	07-44 - FUEL SYS			001		29.27	42.00	1.50
	01-PME - PREV. MAINT.			001		0.00	14.00	0.50
A1	0000026253	01/16/06	44974	/01	08/01			
	01-PMA - PREV. MAINT.			002		16.72	7.50	0.50
A1	0000026259	01/18/06	44990	/02	04/01			
	04-15 - STEERING			002		64.73	45.00	3.00
A1	0000026346	03/03/06	47436	/01	08/01			
	01-PMC - PREV. MAINT.			002		80.00	15.00	1.00
A1	0000026390	04/07/06	49188	/01	08/01			
	01-PMA - PREV. MAINT.			002		11.01	7.50	0.50
	01-PMB - PREV. MAINT.			002		0.00	7.50	0.50
A1	0000026417	04/25/06	49680	/01	04/01			
	07-44 - FUEL SYS			001		483.00	84.00	3.00
	03-06 - DOORS			001		24.32	14.00	0.50
A1	0000026419	04/28/06	49815	/01	04/01			
	05-27 - XMISSION AUTO			001		43.40	28.00	1.00
A1	0000026460	05/11/06	49850	/02	04/01			
	06-35 - BATTERY			001		78.00	14.00	0.50
	04-11 - AXEL FRONT			001		565.27	224.00	8.00

CITY OF DARIEN
 Repair Transaction Cost Detail

Equipment#	Repair Order#	Date	Meter(1)	Shop Loc/ Rep Class	Rep Reason/ Rep Site			
A1	0000026534	10/01/09	93480	/01	08/01			
	<u>Group-System</u>			<u>Mech/Vendor</u>	<u>Work Acc</u>	<u>Part(\$)</u>	<u>Labor(\$)</u>	<u>Hours</u>
	03-02 - HEATER-VENT			001		19.44	28.00	1.00
A1	0000026568	06/09/06	51259	/01	08/01			
	01-PMD - PREV. MAINT.			002		36.48	45.00	3.00
A1	0000026800	07/24/06	54040	/01	08/01			
	01-PMA - PREV. MAINT.			001		9.77	14.00	0.50
A1	0000027065	11/09/06	58691	/01	08/01			
	01-PMA - PREV. MAINT.			002		9.77	7.50	0.50
A1	0000027152	02/06/07	62717	/01	08/01			
	01-PMA - PREV. MAINT.			002		13.12	7.50	0.50
A1	0000027165	02/20/07	63296	/01	08/01			
	02-17 - TIRES,TUBES,ETC			002		358.40	15.00	1.00
A1	0000027238	04/16/07	65800	/02	04/01			
	04-11 - AXEL FRONT			002		99.95	7.50	0.50
A1	0000027336	06/14/07	68315	/01	08/01			
	01-PMA - PREV. MAINT.			002		14.82	7.50	0.50
	01-PMB - PREV. MAINT.			002		381.92	30.00	2.00
	01-PMC - PREV. MAINT.			002		18.89	15.00	1.00
A1	0000027414	09/04/07	71466	/01	08/01			
	01-PMA - PREV. MAINT.			001		14.82	14.00	0.50
A1	0000027608	01/09/08	75668	/01	08/01			
	01-PMA - PREV. MAINT.			001		14.46	14.00	0.50
	07-41 - AIR INTAKE SYS			001		11.56	14.00	0.50
A1	0000027616	01/10/08	75784	/01	08/01			
	02-17 - TIRES,TUBES,ETC			002		35.79	7.50	0.50
A1	0000027767	03/26/08	78938	/01	08/01			
	06-35 - BATTERY			002		116.20	7.50	0.50
A1	0000027838	04/30/08	80075	/01	08/01			
	01-PMA - PREV. MAINT.			001		14.36	28.00	1.00
	03-10 - WIPERS/WASHERS			001		7.31	14.00	0.50
A1	0000028055	09/12/08	83235	/01	08/01			
	01-PMA - PREV. MAINT.			001		15.27	14.00	0.50
	01-PME - PREV. MAINT.			001		0.00	14.00	0.50
	05-25 - TRANSFER CASE			001		18.95	14.00	0.50
A1	0000028095	10/27/08	84662	/01	08/01			
	08-31 - CHARGING SYS			001		159.06	14.00	0.50
A1	0000028212	01/08/09	86680	/01	08/01			
	07-47 - TUNE UP			001		127.44	84.00	3.00
A1	0000028253	02/12/09	87670	/01	08/01			
	01-PMA - PREV. MAINT.			001		35.30	28.00	1.00
	01-PMB - PREV. MAINT.			001		0.00	28.00	1.00
	01-PMC - PREV. MAINT.			001		92.04	28.00	1.00
A1	0000028382	05/29/09	90308	/01	08/01			
	04-15 - STEERING			002		110.00	45.00	3.00
A1	0000028413	06/25/09	90795	/01	08/01			
	05-27 - XMISSION AUTO			002		41.90	30.00	2.00

CITY OF DARIEN
 Repair Transaction Cost Detail

Equipment#	Repair Order#	Date	Meter(1)	Shop Loc/ Rep Class	Rep Reason/ Rep Site			
<u>Group-System</u>				<u>Mech/Vendor</u>	<u>Work Acc</u>	<u>Part(\$)</u>	<u>Labor(\$)</u>	<u>Hours</u>
A1	0000028489	08/13/09	92180	/01	08/01			
	01-PMA - PREV. MAINT.			001		15.99	28.00	1.00
A1	0000028696	01/22/10	97925	01/01	08/01			
	01-PMA - PREV. MAINT.			001		14.59	28.00	1.00
	02-17 - TIRES,TUBES,ETC			001		506.12	42.00	1.50
A1	0000028698	01/27/10	98115	01/02	01/01			
	06-33 - IGNITION SYS			001		69.44	28.00	1.00
A1	0000028737	02/24/10	99260	01/02	01/01			
	06-33 - IGNITION SYS			001		69.44	28.00	1.00
A1	0000028800	04/30/10	101220	01/02	01/01			
	01-PMC - PREV. MAINT.			001		57.20	28.00	1.00
A1	0000028873	06/17/10	103284	01/01	08/01			
	01-PMA - PREV. MAINT.			002		14.17	15.00	1.00
	01-PMD - PREV. MAINT.			002		0.00	7.50	0.50
	07-41 - AIR INTAKE SYS			002		11.56	3.75	0.25
A1	0000028953	08/30/10	106185	01/02	01/01			
	04-13 - BRAKES			001		134.00	70.00	2.50
A1	0000029015	10/25/10	109200	01/01	08/01			
	01-PMA - PREV. MAINT.			001		9.17	28.00	1.00
	01-PMB - PREV. MAINT.			001		0.00	28.00	1.00
	05-22 - AXEL REAR			001		12.50	28.00	1.00
A1	0000029016	10/25/10	109200	01/01	08/01			
	01-PMA - PREV. MAINT.			001		9.17	28.00	1.00
	01-PMB - PREV. MAINT.			001		0.00	28.00	1.00
	05-22 - AXEL REAR			001		6.40	28.00	1.00
A1	0000029160	02/24/11	114536	01/01	08/01			
	01-PMA - PREV. MAINT.			002		14.64	15.00	1.00
	07-41 - AIR INTAKE SYS			002		11.56	0.00	0.00
A1	0000029196	04/07/11	115450	01/02	01/01			
	05-27 - XMISSION AUTO			001		1,832.48	224.00	8.00
	05-27 - XMISSION AUTO			002		0.00	120.00	8.00
A1	0000029359	08/04/11	120425	01/01	08/01			
	01-PMA - PREV. MAINT.			002		15.81	15.00	1.00
A1	0000029458	10/24/11	123800	01/01	08/01			
	01-PME - PREV. MAINT.			002		0.00	3.75	0.25
	01-PMC - PREV. MAINT.			002		0.00	3.75	0.25
	03-02 - HEATER-VENT			002		61.27	30.00	2.00
A1	0000029520	12/14/11	125771	01/01	08/01			
	01-PMA - PREV. MAINT.			002		16.06	7.50	0.50
A1	0000029539	12/02/11	125464	01/02	01/01			
	06-31 - CHARGING SYS			002		213.58	45.00	3.00
A1	0000029577	01/23/12	127399	01/02	01/01			
	06-33 - IGNITION SYS			002		88.41	37.50	2.50
A1	0000029578	01/23/12	95870	01/02	01/01			
	06-36 - BATTERY			002		30.00	7.50	0.50
A1	0000029682	04/02/12	130125	01/03	01/01			

CITY OF DARIEN
 Repair Transaction Cost Detail

Equipment#	Repair Order#	Date	Meter(1)	Shop Loc/ Rep Class	Rep Reason/ Rep Site			
	01-PMB - PREV. MAINT.			002		159.91	30.00	2.00
	01-PMA - PREV. MAINT.			002		13.98	15.00	1.00
A1	0000029729	05/04/12	131420	01/02	01/01			
	<u>Group-System</u>			<u>Mech/Vendor</u>	<u>Work Acc</u>	<u>Part(\$)</u>	<u>Labor(\$)</u>	<u>Hours</u>
	03-06 - DOORS			002		42.59	60.00	4.00
A1	0000029849	08/13/12	135860	01/01	08/01			
	01-PMA - PREV. MAINT.			002		32.42	22.50	1.50
	07-41 - AIR INTAKE SYS			002		19.35	0.00	0.00
	03-10 - WIPERS/WASHERS			002		0.00	15.00	1.00
A1	0000030005	12/18/12	140820	01/02	01/01			
	03-07 - INTERIOR			002		40.05	11.25	0.75
	07-41 - AIR INTAKE SYS			002		414.26	78.75	5.25
	07-42 - COOLING SYS			002		40.61	22.50	1.50
A1	0000030043	01/18/13	140820	01/01	08/01			
	01-PMA - PREV. MAINT.			002		0.00	15.00	1.00
A1	0000030123	04/19/13	145042	01/01	01/01			
	04-15 - STEERING			002		103.96	15.00	1.00
	04-16 - SUSPENSION			002		299.16	30.00	2.00
	02-17 - TIRES,TUBES,ETC			002		616.72	22.50	1.50
	01-PMA - PREV. MAINT.			002		29.80	15.00	1.00
	01-PMC - PREV. MAINT.			002		0.00	487.50	32.50
A1	0000030124	04/22/13	145045	01/01	01/01			
	04-15 - STEERING			002		101.95	0.00	0.00
	03-02 - HEATER-VENT			002		29.39	15.00	1.00
A1	0000030188	06/03/13	146867	01/03	01/01			
	03-06 - DOORS			002		121.50	30.00	2.00
						<u>8,726.17</u>		<u>162.75</u>
							<u>3,253.75</u>	

7,283.29

RESOLUTION NO. _____

A RESOLUTION AUTHORIZING THE PURCHASE OF ONE (1) NEW 2015 FORD F-150 CREW CAB 2WD PICK-UP TRUCK FROM ROESCH FORD IN THE AMOUNT OF \$22,301.00

BE IT RESOLVED BY THE CITY COUNCIL OF THE CITY OF DARIEN, DU PAGE COUNTY, ILLINOIS, as follows:

SECTION 1: The City Council of the City of Darien does hereby authorize the purchase of one (1) new 2015 Ford F-150 Crew Cab 2WD Pick-up Truck from Roesch Ford in the amount of \$22,301.00, a copy of which is attached hereto as "Exhibit A" and is by this reference expressly incorporated herein.

SECTION 2: This Resolution shall be in full force and effect from and after its passage and approval as provided by law.

PASSED BY THE CITY COUNCIL OF THE CITY OF DARIEN, DU PAGE COUNTY, ILLINOIS, this 4th day of May, 2015.

AYES: _____

NAYS: _____

ABSENT: _____

APPROVED BY THE MAYOR OF THE CITY OF DARIEN, DU PAGE COUNTY, ILLINOIS, this 4th day of May, 2015.

KATHLEEN MOESLE WEAVER, MAYOR

ATTEST:

JOANNE E. RAGONA, CITY CLERK

APPROVED AS TO FORM:

CITY ATTORNEY

**SUBURBAN PURCHASING COOPERATIVE
CONTRACT # 148
2015 FORD F150 XL REGULAR CAB 4X2 PICK UP
PRICING WORKSHEET**

18,070.00 +
2,240.00 +
166.00 +
422.00 +
234.00 +
77.00 +
150.00 +
105.00 +
107.00 +
405.00 +
325.00 +
22,301.00

2015 MY F150 4x2 REGULAR CAB PICKUP 6.5' BOX - BASE VEHICLE \$18,070.00



OPTIONS - CAB STYLE		
	UPGRADE TO SUPERCAB	\$2,240.00
	UPGRADE TO SUPERCREW	\$4,383.00
	UPGRADE TO LONG BED (SuperCrew requires 5.0L V8)	\$562.00
	UPGRADE TO 4X4	\$2,752.00



OPTIONS - POWERTRAIN		
99P	2.7L V6 ECOBOOST (NA on 4x4 with 157" or 159.7" WB)	\$678.00
99F	5.0L V8	\$1,360.00
99G	3.5L V6 ECOBOOST (NA 122" WB)	\$1,701.00
XL7	LIMITED SLIP REAR AXLE	\$486.00



AVAILABLE FUNCTIONAL OPTIONS		
66P	SNOW PLOW PREP (4x4 Only req's 5.0L)	\$44.00
41B	SKID PLATES (4x4 Only)	\$137.00
627	HEAVY DUTY PAYLOAD (Req's 53A with 5.0L or 53C with 3.5L)	\$1,279.00
53B	CLASS IV TRAILER HITCH	\$166.00
53A	TRAILER TOW	\$422.00
53C	MAX TRAILER TOW (Req's 3.5L)	\$678.00
67T	TRAILER BRAKE CONTROLLER (Req's 53A & 53B)	\$234.00
65S	36 GAL FUEL TANK (N/A 122" WB)	\$165.00
59R	REMOTE START (Req's XLT Package)	\$525.00



AVAILABLE EXTERIOR OPTIONS		
861	XL SPORT PACKAGE	\$661.00
86A	XL DECOR	\$661.00
301	XLT PACKAGE	\$3,172.00
54M	TELESCOPING TRAILER TOW MIRRORS (MANUAL GLASS)	\$77.00
54Y	TELESCOPING TRAILER TOW MIRRORS (POWER GLASS, HEATED) (Req's 85A)	\$337.00
33E	RUNNING BOARDS - BLACK TUBULAR OR PLATFORM	\$256.00
63T	TAILGATE STEP	\$320.00
59S	FOG LAMPS	\$119.00
63E	STOWABLE BED EXTENDER	\$214.00
76R	REVERSE SENSING (Req's 53B or 53A)	\$234.00
90D	BED DIVIDER (Req's 53B Box Link)	\$320.00
68M	CARGO MANAGEMENT ACCESSORY PKG	\$101.00



AVAILABLE INTERIOR OPTIONS		
85A	POWER EQUIPMENT GROUP	\$998.00
52G	SYNC (Req's 50S)	\$585.00
58B	AM/FM STERO CLOCK W/ SINGLE CD W/ AUX INPUT JACK	\$248.00
50S	CRUISE CONTROL	\$292.00
76C	BACK UP CAMERA	\$275.00
924	FIXED REAR WINDOW PRIVACY GLASS	\$85.00
57Q	REAR WINDOW DEFROSTER	\$188.00
43S	POWER SLIDING REAR WINDOW (Includes 57Q & 924)	\$385.00
47C	CREW CHIEF TELEMATICS (N/A W/ SYNC)	\$682.00

2015 FORD F-150 XL 4X2

PICK UP

CONTRACT # 148



ROESCH FORD COMMERCIAL TRUCK CENTER

Brian Kilduff

briankilduff@roeschtrucks.com

630-279-6000 x2245

www.roeschford.com

Please enter the following:

Agency Name & Address

Contact Name

Phone Number

Purchase Order Number

Total Dollar Amount

Total Number of Units

Delivery Address

Please Submit P.O. & Tax Exempt Letter with Vehicle Order:

Roesch Ford Commercial Truck Center

333 W. Grand Ave.

Bensenville, IL 60106

Phone: (630)279-6000

Fax: (630)451-3509

Contact:

Brian Kilduff briankilduff@roeschtrucks.com

Fred Seng fredseng@roeschtrucks.com

Patti Ferrarini pattiferrarini@roeschtrucks.com

If We Have Missed An Option, Please Contact Our Office.

2015 F-150
REGULAR CAB / SUPERCAB / SUPERCREW® – XL SERIES
STANDARD EQUIPMENT

MECHANICAL

- ★ 3.5L V6 Ti-VCT with Flex-Fuel Capability (std. 4x2/4x4; NA with 157" or 163.7" WB)
- ★ 2.7L V6 EcoBoost® with Start/Stop System (std. 4x2 with 157" or 163.7" WB)
- 5.0L V8 with Flex-Fuel Capability (std. 4x4 with 157" or 163.7" WB)
- 4x4 Electronic Shift-On-the-Fly (ESOF) with Neutral Towing Capability
- AdvanceTrac® w/RSC® (Roll Stability Control™)
- Axle, Front – Independent Front Suspension (IFS)
- Brakes – 4-Wheel Disc with ABS
- ★ Curve Control
- Electronic Six-Speed Automatic Transmission with Tow/Haul Mode
- Fall Safe Cooling
- Hill Start Assist
- Jack
- Parking Brake
 - Mechanical (with 5.0L V8 or 3.5L EcoBoost® engine)
 - Electric (with 3.5L Ti-VCT or 2.7L EcoBoost® engine)★
- ★ SelectShift® Automatic Transmission with Progressive Range Select (NA 3.5L Ti-VCT engine)
- Shock Absorbers, Gas – Heavy-Duty, Outboard Mounted (front/rear)
- Spare Tire Carrier – Rear Under Frame
- Springs, Front – Coil
- Springs, Rear – Leaf, Two-Stage Variable Rate
- Stabilizer Bar, Front
- Steering – Power, Rack-and-Pinion
- Trailer Sway Control
- Trailer Towing – 4-pin wiring, ball mounting provisions in rear bumper

EXTERIOR

- ★ 170 Degree Rear Door (SuperCab)
- Bumper and Fascia, Front – Black
- Bumper, Rear – Black
- Cargo Lamp – Integrated with Center High-mounted Stop Lamp (CHMSL)
- Easy Fuel® Capless Fuel-Filler
- Exhaust – Single Rear
- F-150 Fender Badge
- Fully Boxed Steel Frame
- Grille – Black Three Bar Style with Black Nostrils and Black Surround
- Halogen Headlamps
- Handles, Black – Door and Tailgate with Black Bezel
- Hooks – Pickup Box Tie-Down, four (4)
- Hooks – Front Tow 4x4, two (2)
- Mirrors, Sideview – Manual-folding, Manual Glass with Black Skull Caps
- Spare Tire/Wheel Lock
- Stone Cuffs, Front & Rear
- Tailgate – removable with key lock
- Tires
 - 245/70R 17 BSW all-season tires (A/S) BSW 4x2★
 - 265/70R 17 OWL all-terrain tires (A/T) 4x4★
- Wheels – 17" Silver Steel
- Wipers – Intermittent speed

INTERIOR/COMFORT

- 1st Row Manual Windows
- 2nd Row Fixed Windows (SuperCab)
- 2nd Row Manual Windows (SuperCrew®)
- ★ 2.3" Productivity Screen in Instrument Cluster
- ★ 4.2" Center-stack Screen w/Audio Controls
- Airbags
 - Driver and Passenger Front Airbags
 - Driver and Passenger Seat-Mounted Side Airbags
 - Safety Canopy® Side-Curtain Airbags (1st and 2nd row coverage)
- Air Conditioning Registers – Black Vanes with Chrome Knob
- AM/FM Stereo (speakers; four (4) with Regular Cab, six (6) with SuperCab and SuperCrew®)
- Black Vinyl Floor Covering
- Cupholder, deployable – under 20% seat
- Dome Light
- Fade-to-Off Interior Lighting
- Gauges and Meters – Fuel, Oil Pressure, Transmission Temperature and Engine Coolant Temperature Gauges; Speedometer, Odometer and Tachometer
- Grab Handles
 - Front – A-Pillar, Driver★ and Passenger Side
 - Rear – B-Pillar (SuperCrew®)
- Horn – Dual-Note
- Illuminated Entry
- Manual Air Conditioning, Single Zone
- Manual Locks
- Outside Temperature Display
- Powerpoint 12V – Front
- Rear Window with Fixed Glass and Solar Tint
- Rearview Mirror, Day/Night
- Scuff Plate, Driver and Front-Passenger Doors
- Seat, Front
 - Cloth 40/20/40★
 - 2-Way manual driver/passenger
 - Armrest
- Seat, Rear
 - 60/40 flip-up split seat (SuperCab)
 - 60/40 flip-up split seat with elongated cushion (SuperCrew®)
- Seat Belts, Active Restraint System (ARS). Three-point Manual Lap/Shoulder Belts with Height Adjusters, Pretensioners & Energy Mgmt Retractors on Outside Front Positions. Includes Autolock Features for Child Seats
- SecurLock® Passive Anti-Theft System (PATS)
- SOS Post-Crash Alert System™
- Steering Wheel, Black Urethane – Manual Tilt/Telescoping and Manual Locking
- Tire Pressure Monitoring System (TPMS)
- Visor, Driver Side, Visor with Mirror, Passenger-Side

FUEL TANKS

- Standard Range 23-Gallon

AGENDA MEMO
Municipal Services Committee
April 27, 2015

Issue Statement

Approval of a resolution to enter into an engineering agreement with Christopher B. Burke Engineering, Ltd. for professional services related to the Carlisle Court Bridge Repairs in an amount not to exceed \$18,800.00.

Background/History

Attached is an engineering agreement from Christopher B. Burke Engineering, Ltd. for the preparation of construction plans as they relate to the removal and replacement of the Carlisle Court bridge repair, attached and labeled as Exhibit A. During our 2014 review of the roads, the existing road and concrete culvert was inspected on Carlisle Court and identified that significant cracks were developing within the culvert and adjoining structural walls, see attached Technical Memo dated October 16, 2013 labeled as Attachment A.

The Scope of Services includes the following:

Task 1 - CBBEL will complete a topographic survey of the area. A topographic survey forms the basis from which design plans can be produced. There are no existing plans for the culvert so a survey will be especially important to define the geometry of the existing structure and know what size members to use for replacement. Task 1-\$4,100

Task 2 - Concept Study: CBBEL will interpret the survey results and investigate different replacement alternatives. These may include precast panels with a concrete topping vs. a cast-in place slab. Task 2- \$2,500

Task 3 - Plan Preparation: Bid documents will be produced which include design plans, cost estimate and specifications. An anticipated sheet list includes:

1. Cover Sheet
2. General Notes & Summary of Quantities
3. Existing Conditions & Removal Plan
4. Erosion and Sediment Control
5. Proposed Roadway Plan
6. Proposed Structural Plan
7. Sections & Details

Task 3-\$10,100

Task 4 -Construction Support: CBBEL will assist in the construction of the road by reviewing submittals, answering RFI's and conducting two site visits.

Task 4-\$1,800

Direct Cost Allowance \$300

Funding for the professional services would be expended from the following line item of the FY 15-16 Budget:

ACCOUNT NUMBER	PROJECT CODE	ACCOUNT DESCRIPTION	FY 15-16 BUDGET	PROPOSED EXPENDITURE
25-35-4376	FYE155011	CARLISLE COURT BRIDGE REPAIR	\$ 184,000	\$ 18,800.00

Staff Recommendation

Staff recommends approval of a resolution to enter into an engineering agreement with Christopher B. Burke Engineering, Ltd. for professional services related to the Kentwood Court Bridge Repairs in an amount not to exceed \$18,800.00.

Alternate Consideration

Not approving this proposal.

Decision Mode

This item will be placed on the May 4, 2015 City Council agenda for formal consideration.

TECHNICAL MEMORANDUM



City of Darien Culvert Inspection and Assessment

October 16, 2013

Village of Darien
Public Works Department
1041 S. Frontage Road
Darien, IL 60561

Attention: Dan Gombac, Director of Municipal Services

Project: Kimberly Court, Kentwood Court and Carlisle Court
Culvert Inspection
Technical Memorandum

Dear Mr. Gombac:

Christopher B. Burke Engineering, Ltd. (CBBEL) is pleased to submit this Technical Memorandum which summarizes the field inspection conducted on October 10, 2013 of the three subject culverts, provides a structural assessment of their condition and gives recommendations on what course of action, if any, should be taken to extend their life.

The scope of the inspection was to assess the immediate condition of the culverts to ensure that there was no immediate concern to the traveling public given the longitudinal cracks that can be seen on the roadway surface. No detailed measurements were taken to document inventory items such as span, rise, thickness, etc. at this time. The City was unsure if they had existing plans.

KIMBERLY COURT OVER CREEK:

This single box culvert is in good condition. The culvert is a traditional cast-in-place four-sided box with concrete wingwalls and brick headwalls behind a curb and gutter bituminous roadway.

Using the Federal coding guidelines, this culvert would be rated a 7 (very good). This is based on a scale of 0-9 with 9 being brand new and 0 a collapsed structure.

No repair work is required at this time. It was mentioned that the road may be resurfaced at some point in the future. One can see there is some settlement of the roadway either side of the culvert. There is a slight bump as you drive over the rigid culvert and the bituminous roadway exhibits some transverse cracking. When it comes time for roadway repairs, CBBEL would recommend removal of the roadway surface adjacent to the culvert and recompaction of the material behind the culvert to reduce future settlement.



CHRISTOPHER B. BURKE ENGINEERING, LTD.

9575 W Higgins Road, Suite 600 Rosemont, Illinois 60018-4920 Tel (847) 823-0500 Fax (847) 823-0520

TECHNICAL MEMORANDUM

KENTWOOD COURT OVER CREEK:

This single box "culvert" is not a conventional structure type. There is a base slab and cast-in-place walls but the top slab consists of precast panels set on top of the walls with a concrete wearing surface/deck on top of the panels. A bituminous roadway leads up to the hybrid structure on each approach.

The panels would be rated a 4 (poor condition). There are spalls, delaminated areas and exposed reinforcing on the deck soffit. The reinforcement exhibits some section loss but they appear to be conventional reinforcement and not prestressing strands. There are keyways between the panels which have separated. There is no grout remaining and the panels are acting independently. There are full depth cracks in the wearing surface that extend down to the voided keyways. The panels have some life left in them but should be replaced in the near future.

The walls are in good condition and can be reused in a repair/replacement scenario. There are cracks in the joints at the wingwalls that should be repaired when the deck is replaced. The bituminous approaches have settled at the edge of the culvert. The existing roadway should be removed at the area behind the walls recompacted to help with future settlement concerns.

CBBEL would recommend the City program for the repairs to be made within the next year. Several deck replacement options can be considered. CBBEL can further investigate different alternatives in the next phase of the project.

CARLISLE COURT OVER CREEK:

The Carlisle structure is the same hybrid type as the Kentwood structure. It exhibits the same problems as Kentwood however the panels are not as deteriorated yet. There are only minor areas of spalling and exposed reinforcement. The bottoms of the panels and walls show significant staining indicating leakage does occur though the open joints. This structure will continue to deteriorate and will eventually reach the level as Kentwood. It would currently be rated a 5 or fair condition.

The walls are in good condition and can be reused in a repair/replacement scenario. There are cracks in the joints at the wingwalls that should be repaired when the deck is replaced. The bituminous approaches have settled at the edge of the culvert. The existing roadway should be removed at the area behind the walls recompacted to help with future settlement concerns.

CBBEL would recommend the City program for the repair/replacement of this structure in the next 1-3 years.



CHRISTOPHER B. BURKE ENGINEERING, LTD.

9575 W Higgins Road, Suite 600 Rosemont, Illinois 60018-4920 Tel (847) 823-0500 Fax (847) 823-0520

TECHNICAL MEMORANDUM

SUMMARY:

The condition of the three culverts inspected range from poor to very good. CBBEL would recommend a tiered approach to fixing the problems over the next few years.

- Kimberly Court – No maintenance required
- Kentwood Court – Deck replacement 2014
- Carlisle Court – Deck replacement 2015

Please feel free to contact us to discuss the finding of this Technical Memorandum. We are in position to prepare an estimate for engineering fees and proceed with repair/replacement alternatives if the City wishes to proceed further.

Very truly yours,

Jeffrey C. Ehrhart, PE
Senior Structural Engineer



CHRISTOPHER B. BURKE ENGINEERING, LTD.

9575 W Higgins Road, Suite 600 Rosemont, Illinois 60018-4920 Tel (847) 823-0500 Fax (847) 823-0520



Photo No. 1 – East Elevation



Photo No. 2 – Roadway Above
(looking south)



Photo No. 3 – Roadway
(looking east)



Photo No. 4 – Looking Downstream
(looking east)



Photo No. 5 – Drains



Photo No. 6 – Pipe Penetration



Photo No. 7 – Inside of Culvert



Photo No. 8 – Weir Upstream End



Photo No. 1 – Inside of Culvert



Photo No. 2 – Inside of Culvert



Photo No. 3 – Roadway Surface



Photo No. 4 – Largest Crack is full depth



Photo No. 5 – Underside Precast Panels



Photo No. 6 – Underside Precast Panels



Photo No. 7 – Typical Wall Condition



Photo No. 8 – Cracks in Wingwall Joint



Photo No. 7 – Cast-in-place “sidewalk” on each end



Photo No. 8 – Weir Downstream



Photo No. 1 – Inside of Culvert



Photo No. 2 – Inside of Culvert



Photo No. 3 – Roadway Surface



Photo No. 4 – Concrete Thicknesses



Photo No. 5 – Roadway undermining northwest corner



Photo No. 6 – Cast-in-place "sidewalk" on each end



Photo No. 7 – Looking Downstream



Photo No. 8 – Pipe Penetration



Photo No. 7 – Crack in Wingwall Joint



Photo No. 8 – Concrete Width

RESOLUTION NO. _____

A RESOLUTION TO ENTER INTO AN ENGINEERING AGREEMENT WITH CHRISTOPHER B. BURKE ENGINEERING, LTD. FOR PROFESSIONAL SERVICES RELATED TO THE CARLISLE COURT BRIDGE REPAIRS IN AN AMOUNT NOT TO EXCEED \$18,800.00

BE IT RESOLVED BY THE CITY COUNCIL OF THE CITY OF DARIEN, DU PAGE COUNTY, ILLINOIS, as follows:

SECTION 1: The City Council of the City of Darien hereby authorizes the Mayor to enter into an Engineering Agreement with Christopher B. Burke Engineering, Ltd. for professional services related to the Carlisle Court Bridge repairs in an amount not to exceed \$18,800.00, a copy of which is attached hereto as "Exhibit A" and is by this reference expressly incorporated herein.

SECTION 2: This Resolution shall be in full force and effect from and after its passage and approval as provided by law.

PASSED BY THE CITY COUNCIL OF THE CITY OF DARIEN, DU PAGE COUNTY, ILLINOIS, this 4th day of May, 2015.

AYES: _____

NAYS: _____

ABSENT: _____

APPROVED BY THE MAYOR OF THE CITY OF DARIEN, DU PAGE COUNTY, ILLINOIS, this 4th day of May, 2015.

KATHLEEN MOESLE WEAVER, MAYOR

ATTEST:

JOANNE E. RAGONA, CITY CLERK

APPROVED AS TO FORM:

CITY ATTORNEY

**CHRISTOPHER B. BURKE ENGINEERING, LTD.**

9575 West Higgins Road Suite 600 Rosemont, Illinois 60018 TEL (847) 823-0500 FAX (847) 823-0520

April 13, 2015

Sent via electronic mail

City of Darien
Public Works Department
1041 S. Frontage Road
Darien, IL 60561

Attention: Dan Gombac, Director of Municipal Services

Subject: Carlisle Court Culvert Repairs - Engineering Proposal

Dear Mr. Gombac:

Christopher B. Burke Engineering, Ltd. (CBBEL) is pleased to submit this proposal for professional engineering services for the above referenced subject. This proposal includes our Understanding of the Assignment, Scope of Services, and Estimate of Fee.

UNDERSTANDING OF THE ASSIGNMENT

CBBEL understands that the City of Darien is in need of repair/replacement of an existing culvert at Carlisle Court. The existing top slab of the culvert is in poor condition and there is concern of its remaining capacity. CBBEL visited the site on October 10, 2013 to investigate its condition and produced a Technical Memorandum dated October 16, 2013 summarizing our findings.

At the request of the City, CBBEL is preparing this proposal for the preparation of contract documents for the repair of the Carlisle Court Culvert. The side walls and bottom slab are in good condition. This proposal follows the recommendation of the Technical Memo which is to replace the top slab only as well as approach pavement work.

SCOPE OF SERVICES

Task 1 – Survey: CBBEL will complete a topographic survey of the area. A topographic survey forms the basis from which design plans can be produced. There are no existing plans for the culvert so a survey will be especially important to define the geometry of the existing structure and know what size members to use for replacement.

Task 2 – Inspection and Concept Study: Given that it has been over a year since the initial inspection, CBBEL will inspect the culvert again to confirm its condition and the scope of work. We will interpret the survey results and investigate different replacement alternatives. These may include precast panels with a concrete topping vs. a cast-in-place slab.

Task 3 – Plan Preparation: Bid documents will be produced which include design plans, cost estimate and specifications. An anticipated sheet list includes:

1. Cover Sheet
2. General Notes & Summary of Quantities

3. Maintenance of Traffic
4. Existing Conditions & Removal Plan
5. Erosion and Sediment Control
6. Proposed Roadway Plan
7. Proposed Structural Plan
8. Sections & Details

Task 4 – Construction Support: This includes bidding assistance, review of shop drawings and answering RFI's. Part-time construction observation and coordination with the Contractor will be handled under a separate agreement on a Time and Material basis.

ESTIMATE OF FEE

CBBEL estimates the following fees for each of the tasks described above:

Task 1 – Survey	\$ 4,100
Task 2 – Inspection & Concept Study	\$ 2,500
Task 3 – Plan Preparation	\$ 10,100
Task 4 – Construction Support	\$ 1,800
Direct Cost Allowance	\$ 300
TOTAL	\$ 18,800

We will bill you at the hourly rates specified on the attached Schedule of Charges and establish our contract in accordance with the attached General Terms and Conditions. An Allowance for Direct costs for printing, mailing, travel, securing any permits, etc. is included in the Fee Estimate. The actual charges will be billed as required. These General Terms and Conditions are expressly incorporated into and are an integral part of this contract for professional services. Any Supplemental Services will be performed as requested and billed on a time and materials basis.

Please sign and return one copy of this agreement as an indication of acceptance and notice to proceed. Please feel free to contact us anytime.

Sincerely,



Christopher B. Burke, PhD, PE, D.WRE, Dist.M. ASCE
President

Encl. Schedule of Charges
General Terms and Conditions

THIS PROPOSAL, SCHEDULE OF CHARGES AND GENERAL TERMS AND CONDITIONS ACCEPTED FOR CITY OF DARIEN.

BY: _____
TITLE: _____
DATE: _____

**CHRISTOPHER B. BURKE ENGINEERING, LTD.
GENERAL TERMS AND CONDITIONS**

1. **Relationship Between Engineer and Client:** Christopher B. Burke Engineering, Ltd. (Engineer) shall serve as Client's professional engineer consultant in those phases of the Project to which this Agreement applies. This relationship is that of a buyer and seller of professional services and as such the Engineer is an independent contractor in the performance of this Agreement and it is understood that the parties have not entered into any joint venture or partnership with the other. The Engineer shall not be considered to be the agent of the Client. Nothing contained in this Agreement shall create a contractual relationship with a cause of action in favor of a third party against either the Client or Engineer.

Furthermore, causes of action between the parties to this Agreement pertaining to acts of failures to act shall be deemed to have accrued and the applicable statute of limitations shall commence to run not later than the date of substantial completion.

2. **Responsibility of the Engineer:** Engineer will strive to perform services under this Agreement in accordance with generally accepted and currently recognized engineering practices and principles, and in a manner consistent with that level of care and skill ordinarily exercised by members of the profession currently practicing in the same locality under similar conditions. No other representation, express or implied, and no warranty or guarantee is included or intended in this Agreement, or in any report, opinion, document, or otherwise.

Notwithstanding anything to the contrary which may be contained in this Agreement or any other material incorporated herein by reference, or in any Agreement between the Client and any other party concerning the Project, the Engineer shall not have control or be in charge of and shall not be responsible for the means, methods, techniques, sequences or procedures of construction, or the safety, safety precautions or programs of the Client, the construction contractor, other contractors or subcontractors performing any of the work or providing any of the services on the Project. Nor shall the Engineer be responsible for the acts or omissions of the Client, or for the failure of the Client, any architect, engineer, consultant, contractor or subcontractor to carry out their respective responsibilities in accordance with the Project documents, this Agreement or any other agreement concerning the Project. Any provision which purports to amend this provision shall be without effect unless it contains a reference that the content of this condition is expressly amended for the purposes described in such amendment and is signed by the Engineer.

3. **Changes:** Client reserves the right by written change order or amendment to make changes in requirements, amount of work, or engineering time schedule adjustments, and Engineer and Client shall negotiate appropriate adjustments acceptable to both parties to accommodate any changes, if commercially possible.
4. **Suspension of Services:** Client may, at any time, by written order to Engineer (Suspension of Services Order) require Engineer to stop all, or any part, of the services required by this Agreement. Upon receipt of such an order, Engineer shall immediately comply with its terms and take all reasonable steps to minimize the costs associated with the services affected by such order. Client, however, shall pay all costs incurred by the suspension, including all costs necessary to maintain continuity and for the resumptions

of the services upon expiration of the Suspension of Services Order. Engineer will not be obligated to provide the same personnel employed prior to suspension, when the services are resumed, in the event that the period of suspension is greater than thirty (30) days.

5. **Termination:** This Agreement may be terminated by either party upon thirty (30) days written notice in the event of substantial failure by the other party to perform in accordance with the terms hereof through no fault of the terminating party. This Agreement may be terminated by Client, under the same terms, whenever Client shall determine that termination is in its best interests. Cost of termination, including salaries, overhead and fee, incurred by Engineer either before or after the termination date shall be reimbursed by Client.
6. **Documents Delivered to Client:** Drawings, specifications, reports, and any other Project Documents prepared by Engineer in connection with any or all of the services furnished hereunder shall be delivered to the Client for the use of the Client. Engineer shall have the right to retain originals of all Project Documents and drawings for its files. Furthermore, it is understood and agreed that the Project Documents such as, but not limited to reports, calculations, drawings, and specifications prepared for the Project, whether in hard copy or machine readable form, are instruments of professional service intended for one-time use in the construction of this Project. These Project Documents are and shall remain the property of the Engineer. The Client may retain copies, including copies stored on magnetic tape or disk, for information and reference in connection with the occupancy and use of the Project.

When and if record drawings are to be provided by the Engineer, Client understands that information used in the preparation of record drawings is provided by others and Engineer is not responsible for accuracy, completeness, nor sufficiency of such information. Client also understands that the level of detail illustrated by record drawings will generally be the same as the level of detail illustrated by the design drawing used for project construction. If additional detail is requested by the Client to be included on the record drawings, then the Client understands and agrees that the Engineer will be due additional compensation for additional services.

It is also understood and agreed that because of the possibility that information and data delivered in machine readable form may be altered, whether inadvertently or otherwise, the Engineer reserves the right to retain the original tapes/disks and to remove from copies provided to the Client all identification reflecting the involvement of the Engineer in their preparation. The Engineer also reserves the right to retain hard copy originals of all Project Documentation delivered to the Client in machine readable form, which originals shall be referred to and shall govern in the event of any inconsistency between the two.

The Client understands that the automated conversion of information and data from the system and format used by the Engineer to an alternate system or format cannot be accomplished without the introduction of inexactitudes, anomalies, and errors. In the event Project Documentation provided to the Client in machine readable form is so converted, the Client agrees to assume all risks associated therewith and, to the fullest

extent permitted by law, to hold harmless and indemnify the Engineer from and against all claims, liabilities, losses, damages, and costs, including but not limited to attorney's fees, arising therefrom or in connection therewith.

The Client recognizes that changes or modifications to the Engineer's instruments of professional service introduced by anyone other than the Engineer may result in adverse consequences which the Engineer can neither predict nor control. Therefore, and in consideration of the Engineer's agreement to deliver its instruments of professional service in machine readable form, the Client agrees, to the fullest extent permitted by law, to hold harmless and indemnify the Engineer from and against all claims, liabilities, losses, damages, and costs, including but not limited to attorney's fees, arising out of or in any way connected with the modification, misinterpretation, misuse, or reuse by others of the machine readable information and data provided by the Engineer under this Agreement. The foregoing indemnification applies, without limitation, to any use of the Project Documentation on other projects, for additions to this Project, or for completion of this Project by others, excepting only such use as may be authorized, in writing, by the Engineer.

7. **Reuse of Documents:** All Project Documents including but not limited to reports, opinions of probable costs, drawings and specifications furnished by Engineer pursuant to this Agreement are intended for use on the Project only. They cannot be used by Client or others on extensions of the Project or any other project. Any reuse, without specific written verification or adaptation by Engineer, shall be at Client's sole risk, and Client shall indemnify and hold harmless Engineer from all claims, damages, losses, and expenses including attorney's fees arising out of or resulting therefrom.

The Engineer shall have the right to include representations of the design of the Project, including photographs of the exterior and interior, among the Engineer's promotional and professional materials. The Engineer's materials shall not include the Client's confidential and proprietary information if the Client has previously advised the Engineer in writing of the specific information considered by the Client to be confidential and proprietary.

8. **Standard of Practice:** The Engineer will strive to conduct services under this agreement in a manner consistent with that level of care and skill ordinarily exercised by members of the profession currently practicing in the same locality under similar conditions as of the date of this Agreement.
9. **Compliance With Laws:** The Engineer will strive to exercise usual and customary professional care in his/her efforts to comply with those laws, codes, ordinance and regulations which are in effect as of the date of this Agreement.

With specific respect to prescribed requirements of the Americans with Disabilities Act of 1990 or certified state or local accessibility regulations (ADA), Client understands ADA is a civil rights legislation and that interpretation of ADA is a legal issue and not a design issue and, accordingly, retention of legal counsel (by Client) for purposes of interpretation is advisable. As such and with respect to ADA, Client agrees to waive any action against Engineer, and to indemnify and defend Engineer against any claim arising from Engineer's alleged failure to meet ADA requirements prescribed.

Further to the law and code compliance, the Client understands that the Engineer will strive to provide designs in accordance with the prevailing Standards of Practice as previously set forth, but that the Engineer does not warrant that any reviewing agency having jurisdiction will not for its own purposes comment, request changes and/or additions to such designs. In the event such design requests are made by a reviewing agency, but which do not exist in the form of a written regulation, ordinance or other similar document as published by the reviewing agency, then such design changes (at substantial variance from the intended design developed by the Engineer), if effected and incorporated into the project documents by the Engineer, shall be considered as Supplementary Task(s) to the Engineer's Scope of Service and compensated for accordingly.

10. Indemnification: Engineer shall indemnify and hold harmless Client up to the amount of this contract fee (for services) from loss or expense, including reasonable attorney's fees for claims for personal injury (including death) or property damage to the extent caused by the sole negligent act, error or omission of Engineer.

Client shall indemnify and hold harmless Engineer under this Agreement, from loss or expense, including reasonable attorney's fees, for claims for personal injuries (including death) or property damage arising out of the sole negligent act, error omission of Client.

In the event of joint or concurrent negligence of Engineer and Client, each shall bear that portion of the loss or expense that its share of the joint or concurrent negligence bears to the total negligence (including that of third parties), which caused the personal injury or property damage.

Engineer shall not be liable for special, incidental or consequential damages, including, but not limited to loss of profits, revenue, use of capital, claims of customers, cost of purchased or replacement power, or for any other loss of any nature, whether based on contract, tort, negligence, strict liability or otherwise, by reasons of the services rendered under this Agreement.

11. Opinions of Probable Cost: Since Engineer has no control over the cost of labor, materials or equipment, or over the Contractor(s) method of determining process, or over competitive bidding or market conditions, his/her opinions of probable Project Construction Cost provided for herein are to be made on the basis of his/her experience and qualifications and represent his/her judgement as a design professional familiar with the construction industry, but Engineer cannot and does not guarantee that proposal, bids or the Construction Cost will not vary from opinions of probable construction cost prepared by him/her. If prior to the Bidding or Negotiating Phase, Client wishes greater accuracy as to the Construction Cost, the Client shall employ an independent cost estimator Consultant for the purpose of obtaining a second construction cost opinion independent from Engineer.
12. Governing Law & Dispute Resolutions: This Agreement shall be governed by and construed in accordance with Articles previously set forth by (Item 9 of) this Agreement, together with the laws of the State of Illinois.

Any claim, dispute or other matter in question arising out of or related to this Agreement, which can not be mutually resolved by the parties of this Agreement, shall be subject to mediation as a condition precedent to arbitration (if arbitration is agreed upon by the parties of this Agreement) or the institution of legal or equitable proceedings by either party. If such matter relates to or is the subject of a lien arising out of the Engineer's services, the Engineer may proceed in accordance with applicable law to comply with the lien notice or filing deadlines prior to resolution of the matter by mediation or by arbitration.

The Client and Engineer shall endeavor to resolve claims, disputes and other matters in question between them by mediation which, unless the parties mutually agree otherwise, shall be in accordance with the Construction Industry Mediation Rules of the American Arbitration Association currently in effect. Requests for mediation shall be filed in writing with the other party to this Agreement and with the American Arbitration Association. The request may be made concurrently with the filing of a demand for arbitration but, in such event, mediation shall proceed in advance of arbitration or legal or equitable proceedings, which shall be stayed pending mediation for a period of 60 days from the date of filing, unless stayed for a longer period by agreement of the parties or court order.

The parties shall share the mediator's fee and any filing fees equally. The mediation shall be held in the place where the Project is located, unless another location is mutually agreed upon. Agreements reached in mediation shall be enforceable as settlement agreements in any court having jurisdiction thereof.

13. Successors and Assigns: The terms of this Agreement shall be binding upon and inure to the benefit of the parties and their respective successors and assigns: provided, however, that neither party shall assign this Agreement in whole or in part without the prior written approval of the other.
14. Waiver of Contract Breach: The waiver of one party of any breach of this Agreement or the failure of one party to enforce at any time, or for any period of time, any of the provisions hereof, shall be limited to the particular instance, shall not operate or be deemed to waive any future breaches of this Agreement and shall not be construed to be a waiver of any provision, except for the particular instance.
15. Entire Understanding of Agreement: This Agreement represents and incorporates the entire understanding of the parties hereto, and each party acknowledges that there are no warranties, representations, covenants or understandings of any kind, matter or description whatsoever, made by either party to the other except as expressly set forth herein. Client and the Engineer hereby agree that any purchase orders, invoices, confirmations, acknowledgments or other similar documents executed or delivered with respect to the subject matter hereof that conflict with the terms of the Agreement shall be null, void and without effect to the extent they conflict with the terms of this Agreement.
16. Amendment: This Agreement shall not be subject to amendment unless another instrument is duly executed by duly authorized representatives of each of the parties and entitled "Amendment of Agreement".

17. **Severability of Invalid Provisions:** If any provision of the Agreement shall be held to contravene or to be invalid under the laws of any particular state, county or jurisdiction where used, such contravention shall not invalidate the entire Agreement, but it shall be construed as if not containing the particular provisions held to be invalid in the particular state, country or jurisdiction and the rights or obligations of the parties hereto shall be construed and enforced accordingly.
18. **Force Majeure:** Neither Client nor Engineer shall be liable for any fault or delay caused by any contingency beyond their control including but not limited to acts of God, wars, strikes, walkouts, fires, natural calamities, or demands or requirements of governmental agencies.
19. **Subcontracts:** Engineer may subcontract portions of the work, but each subcontractor must be approved by Client in writing.
20. **Access and Permits:** Client shall arrange for Engineer to enter upon public and private property and obtain all necessary approvals and permits required from all governmental authorities having jurisdiction over the Project. Client shall pay costs (including Engineer's employee salaries, overhead and fee) incident to any effort by Engineer toward assisting Client in such access, permits or approvals, if Engineer perform such services.
21. **Designation of Authorized Representative:** Each party (to this Agreement) shall designate one or more persons to act with authority in its behalf in respect to appropriate aspects of the Project. The persons designated shall review and respond promptly to all communications received from the other party.
22. **Notices:** Any notice or designation required to be given to either party hereto shall be in writing, and unless receipt of such notice is expressly required by the terms hereof shall be deemed to be effectively served when deposited in the mail with sufficient first class postage affixed, and addressed to the party to whom such notice is directed at such party's place of business or such other address as either party shall hereafter furnish to the other party by written notice as herein provided.
23. **Limit of Liability:** The Client and the Engineer have discussed the risks, rewards, and benefits of the project and the Engineer's total fee for services. In recognition of the relative risks and benefits of the Project to both the Client and the Engineer, the risks have been allocated such that the Client agrees that to the fullest extent permitted by law, the Engineer's total aggregate liability to the Client for any and all injuries, claims, costs, losses, expenses, damages of any nature whatsoever or claim expenses arising out of this Agreement from any cause or causes, including attorney's fees and costs, and expert witness fees and costs, shall not exceed the total Engineer's fee for professional engineering services rendered on this project as made part of this Agreement. Such causes included but are not limited to the Engineer's negligence, errors, omissions, strict liability or breach of contract. It is intended that this limitation apply to any and all liability or cause of action however alleged or arising, unless otherwise prohibited by law.

24. **Client's Responsibilities:** The Client agrees to provide full information regarding requirements for and about the Project, including a program which shall set forth the Client's objectives, schedule, constraints, criteria, special equipment, systems and site requirements.

The Client agrees to furnish and pay for all legal, accounting and insurance counseling services as may be necessary at any time for the Project, including auditing services which the Client may require to verify the Contractor's Application for Payment or to ascertain how or for what purpose the Contractor has used the money paid by or on behalf of the Client.

The Client agrees to require the Contractor, to the fullest extent permitted by law, to indemnify, hold harmless, and defend the Engineer, its consultants, and the employees and agents of any of them from and against any and all claims, suits, demands, liabilities, losses, damages, and costs ("Losses"), including but not limited to costs of defense, arising in whole or in part out of the negligence of the Contractor, its subcontractors, the officers, employees, agents, and subcontractors of any of them, or anyone for whose acts any of them may be liable, regardless of whether or not such Losses are caused in part by a party indemnified hereunder. Specifically excluded from the foregoing are Losses arising out of the preparation or approval of maps, drawings, opinions, reports, surveys, change orders, designs, or specifications, and the giving of or failure to give directions by the Engineer, its consultants, and the agents and employees of any of them, provided such giving or failure to give is the primary cause of Loss. The Client also agrees to require the Contractor to provide to the Engineer the required certificate of insurance.

The Client further agrees to require the Contractor to name the Engineer, its agents and consultants as additional insureds on the Contractor's policy or policies of comprehensive or commercial general liability insurance. Such insurance shall include products and completed operations and contractual liability coverages, shall be primary and noncontributing with any insurance maintained by the Engineer or its agents and consultants, and shall provide that the Engineer be given thirty days, unqualified written notice prior to any cancellation thereof.

In the event the foregoing requirements, or any of them, are not established by the Client and met by the Contractor, the Client agrees to indemnify and hold harmless the Engineer, its employees, agents, and consultants from and against any and all Losses which would have been indemnified and insured against by the Contractor, but were not.

When Contract Documents prepared under the Scope of Services of this contract require insurance(s) to be provided, obtained and/or otherwise maintained by the Contractor, the Client agrees to be wholly responsible for setting forth any and all such insurance requirements. Furthermore, any document provided for Client review by the Engineer under this Contract related to such insurance(s) shall be considered as sample insurance requirements and not the recommendation of the Engineer. Client agrees to have their own risk management department review any and all insurance requirements for adequacy and to determine specific types of insurance(s) required for the project. Client further agrees that decisions concerning types and amounts of insurance are

specific to the project and shall be the product of the Client. As such, any and all insurance requirements made part of Contract Documents prepared by the Engineer are not to be considered the Engineer's recommendation, and the Client shall make the final decision regarding insurance requirements.

25. **Information Provided by Others:** The Engineer shall indicate to the Client the information needed for rendering of the services of this Agreement. The Client shall provide to the Engineer such information as is available to the Client and the Client's consultants and contractors, and the Engineer shall be entitled to rely upon the accuracy and completeness thereof. The Client recognizes that it is impossible for the Engineer to assure the accuracy, completeness and sufficiency of such information, either because it is impossible to verify, or because of errors or omissions which may have occurred in assembling the information the Client is providing. Accordingly, the Client agrees, to the fullest extent permitted by law, to indemnify and hold the Engineer and the Engineer's subconsultants harmless from any claim, liability or cost (including reasonable attorneys' fees and cost of defense) for injury or loss arising or allegedly arising from errors, omissions or inaccuracies in documents or other information provided by the Client to the Engineer.

26. **Payment:** Client shall be invoiced once each month for work performed during the preceding period. Client agrees to pay each invoice within thirty (30) days of its receipt. The client further agrees to pay interest on all amounts invoiced and not paid or objected to for valid cause within said thirty (30) day period at the rate of eighteen (18) percent per annum (or the maximum interest rate permitted under applicable law, whichever is the lesser) until paid. Client further agrees to pay Engineer's cost of collection of all amounts due and unpaid after sixty (60) days, including court costs and reasonable attorney's fees, as well as costs attributed to suspension of services accordingly and as follows:

Collection Costs. In the event legal action is necessary to enforce the payment provisions of this Agreement, the Engineer shall be entitled to collect from the Client any judgement or settlement sums due, reasonable attorneys' fees, court costs and expenses incurred by the Engineer in connection therewith and, in addition, the reasonable value of the Engineer's time and expenses spent in connection with such collection action, computed at the Engineer's prevailing fee schedule and expense policies.

Suspension of Services. If the Client fails to make payments when due or otherwise is in breach of this Agreement, the Engineer may suspend performance of services upon five (5) calendar days' notice to the Client. The Engineer shall have no liability whatsoever to the Client for any costs or damages as a result of such suspension caused by any breach of this Agreement by the Client. Client will reimburse Engineer for all associated costs as previously set forth in (Item 4 of) this Agreement.

27. When construction observation tasks are part of the service to be performed by the Engineer under this Agreement, the Client will include the following clause in the construction contract documents and Client agrees not to modify or delete it:

Kotecki Waiver. Contractor (and any subcontractor into whose subcontract this clause is incorporated) agrees to assume the entire liability for all personal injury claims suffered by its own employees, including without limitation claims under the Illinois Structural Work Act, asserted by persons allegedly injured on the Project; waives any limitation of liability defense based upon the Worker's Compensation Act, court interpretations of said Act or otherwise; and to the fullest extent permitted by law, agrees to indemnify and hold harmless and defend Owner and Engineer and their agents, employees and consultants (the "Indemnitees") from and against all such loss, expense, damage or injury, including reasonable attorneys' fees, that the Indemnitees may sustain as a result of such claims, except to the extent that Illinois law prohibits indemnity for the Indemnitees' own negligence. The Owner and Engineer are designated and recognized as explicit third party beneficiaries of the Kotecki Waiver within the general contract and all subcontracts entered into in furtherance of the general contract.

28. **Job Site Safety/Supervision & Construction Observation:** The Engineer shall neither have control over or charge of, nor be responsible for, the construction means, methods, techniques, sequences of procedures, or for safety precautions and programs in connection with the Work since they are solely the Contractor's rights and responsibilities. The Client agrees that the Contractor shall supervise and direct the work efficiently with his/her best skill and attention; and that the Contractor shall be solely responsible for the means, methods, techniques, sequences and procedures of construction and safety at the job site. The Client agrees and warrants that this intent shall be carried out in the Client's contract with the Contractor. The Client further agrees that the Contractor shall be responsible for initiating, maintaining and supervising all safety precautions and programs in connection with the work; and that the Contractor shall take all necessary precautions for the safety of, and shall provide the necessary protection to prevent damage, injury or loss to all employees on the subject site and all other persons who may be affected thereby. The Engineer shall have no authority to stop the work of the Contractor or the work of any subcontractor on the project.

When construction observation services are included in the Scope of Services, the Engineer shall visit the site at intervals appropriate to the stage of the Contractor's operation, or as otherwise agreed to by the Client and the Engineer to: 1) become generally familiar with and to keep the Client informed about the progress and quality of the Work; 2) to strive to bring to the Client's attention defects and deficiencies in the Work and; 3) to determine in general if the Work is being performed in a manner indicating that the Work, when fully completed, will be in accordance with the Contract Documents. However, the Engineer shall not be required to make exhaustive or continuous on-site inspections to check the quality or quantity of the Work. If the Client desires more extensive project observation, the Client shall request that such services be provided by the Engineer as Additional and Supplemental Construction Observation Services in accordance with the terms of this Agreement.

The Engineer shall not be responsible for any acts or omissions of the Contractor, subcontractor, any entity performing any portions of the Work, or any agents or employees of any of them. The Engineer does not guarantee the performance of the

Contractor and shall not be responsible for the Contractor's failure to perform its Work in accordance with the Contract Documents or any applicable laws, codes, rules or regulations.

When municipal review services are included in the Scope of Services, the Engineer (acting on behalf of the municipality), when acting in good faith in the discharge of its duties, shall not thereby render itself liable personally and is, to the maximum extent permitted by law, relieved from all liability for any damage that may accrue to persons or property by reason of any act or omission in the discharge of its duties. Any suit brought against the Engineer which involve the acts or omissions performed by it in the enforcement of any provisions of the Client's rules, regulation and/or ordinance shall be defended by the Client until final termination of the proceedings. The Engineer shall be entitled to all defenses and municipal immunities that are, or would be, available to the Client.

29. Insurance and Indemnification: The Engineer and the Client understand and agree that the Client will contractually require the Contractor to defend and indemnify the Engineer and/or any subconsultants from any claims arising from the Work. The Engineer and the Client further understand and agree that the Client will contractually require the Contractor to procure commercial general liability insurance naming the Engineer as an additional named insured with respect to the work. The Contractor shall provide to the Client certificates of insurance evidencing that the contractually required insurance coverage has been procured. However, the Contractor's failure to provide the Client with the requisite certificates of insurance shall not constitute a waiver of this provision by the Engineer.

The Client and Engineer waive all rights against each other and against the Contractor and consultants, agents and employees of each of them for damages to the extent covered by property insurance during construction. The Client and Engineer each shall require similar waivers from the Contractor, consultants, agents and persons or entities awarded separate contracts administered under the Client's own forces.

30. Hazardous Materials/Pollutants: Unless otherwise provided by this Agreement, the Engineer and Engineer's consultants shall have no responsibility for the discovery, presence, handling, removal or disposal of or exposure of persons to hazardous materials/pollutants in any form at the Project site, including but not limited to mold/mildew, asbestos, asbestos products, polychlorinated biphenyl (PCB) or other toxic/hazardous/pollutant type substances.

Furthermore, Client understands that the presence of mold/mildew and the like are results of prolonged or repeated exposure to moisture and the lack of corrective action. Client also understands that corrective action is a operation, maintenance and repair activity for which the Engineer is not responsible.

June 13, 2005

P:\Proposals\Terms and Conditions\GT&C 2005.081305.doc

**CHRISTOPHER B. BURKE ENGINEERING, LTD.
STANDARD CHARGES FOR PROFESSIONAL SERVICES
JANUARY, 2015**

<u>Personnel</u>	<u>Charges*</u> <u>(\$/Hr)</u>
Principal	257
Engineer VI	225
Engineer V	185
Engineer IV	148
Engineer III	134
Engineer I/II	106
Survey V	207
Survey IV	175
Survey III	149
Survey II	108
Survey I	84
Engineering Technician V	175
Engineering Technician IV	142
Engineering Technician III	127
Engineering Technician I/II	111
CAD Manager	154
Assistant CAD Manager	135
CAD II	134
CAD I	105
GIS Specialist III	128
GIS Specialist I/II	71
Landscape Architect	148
Environmental Resource Specialist V	189
Environmental Resource Specialist IV	146
Environmental Resource Specialist III	122
Environmental Resource Specialist I/II	100
Environmental Resource Technician	96
Administrative	95
Engineering Intern	57
Information Technician III	113
Information Technician I/II	104

Direct Costs

Outside Copies, Blueprints, Messenger, Delivery Services, Mileage Cost + 12%

*Charges include overhead and profit

Christopher B. Burke Engineering, Ltd. reserves the right to increase these rates and costs by 5% after December 31, 2015.

AGENDA MEMO
Municipal Services Committee
April 27, 2015

ISSUE STATEMENT

Approval of a resolution accepting a proposal from K&K Well Drilling in the amount of \$54,800 for the abandonment of Wells No 2, 5 and 7.

BACKGROUND/HISTORY

According to archived records the best information we have for:

Well No 2 is a 273 feet deep shallow well that has been in service since approximately 1970's. The well is located at 1220 Plainfield Rd. in the garage at the water tower. In late 2014, during routine sampling it was identified that the well was decreasing in production of water and eventually producing no water in early 2015. Staff had contacted Layne Western to diagnose the problem. In order to restore the well to its optimal non restricted flow capacity of approximately 300 gallons per minute would cost approximately \$45,000. The cost to remove the equipment and cap the well would be \$16,600.

Well No 5 is a 200 feet deep shallow well that has been in service since approximately 1970's. The well is located approximately 1930 Manning Rd. in the garage of the water plant. In mid 2014, during routine sampling it stopped producing water and could not be sampled in accordance with IEPA requirements. Staff had contacted Layne Western to diagnose the problem. In order to restore the well to its optimal non restricted flow capacity of approximately 440 gallons per minute would cost approximately \$43,000. The cost to remove the equipment and cap the well would be \$13,350.

Well No 7 is a 220 feet deep shallow well that has been in service since approximately 1970's. The well is located approximately 1000 feet West of Bailey Rd. on Lakeview Dr. Throughout the last several years the routine water sampling did not meet the IEPA requirements. In 2013 & 2014 the Well had several routine samples that did not pass routine IEPA sampling. Staff was able to get the Wells to pass sampling by resampling with extended run time. Currently the Well does still produce water, although overall Well production is decreasing. Staff had contacted Layne Western on several instances to diagnose the problem. While attempts to correct the problem with chemicals were made the production continued to deteriorate. In order to restore the well to its optimal non restricted flow capacity of approximately 850 gallons per minute would cost approximately \$43,000. The cost to remove the equipment and cap the well would be \$24,850.

As additional background information the City receives its water supply from the DuPage Water Commission via transmission mains from the City of Chicago. The DuPage Water Commission has been in service since 1992 with no disruptions to the supply of water. In addition, throughout the last 10 years the City Council has made great strives to upgrade and maintain an optimal potable water system, including two days of water storage in the event of an emergency. The City pumps approximately 2,100 gallons of water per minute. The quality of raw well water usually is not suited for drinking water due to the high iron and other volatile organic contaminants and would require extensive treatment equipment to produce potable water. While the wells could produce approximately 1,590 gallons per minute, it is unknown to how far the wells could pump to distribute water to the entire City.

(See Attached Map) Upon review, Staff is requesting the abandonment process of the shallow wells 2, 5 and 7 as prescribed by the Illinois Department of Health.

The proposals for the abandonment of Well No 2, 5 and 7 are attached and labeled as Exhibit A. The awarded vendor will be responsible for removing all well components from all of the sites.

The proposed well abandonment would be funded from the following line item:

ACCOUNT NUMBER	ACCOUNT DESCRIPTION	FY 15-16 BUDGET	PROPOSED EXPENDITURE	PROPOSED BALANCE
12-51-4390	Water System Maintenance	\$55,150.00	\$ 54,800.00	\$ 350.00

STAFF RECOMMENDATION

Staff recommends approval to accept a proposal from K&K Well Drilling in the amount of \$54,800.00 for the abandonment of Wells No 2, 5 and 7.

ALTERNATE CONSIDERATION

Not approving this proposal.

DECISION MODE

This item will be placed on the May 4, 2015 agenda for formal consideration by the City Council.

**CITY OF DARIEN PUBLIC WORKS
1702 PLAINFIELD ROAD
DARIEN, IL 60561**

ATTACHMENT A

Competitive Quotes for Wells 2, 5 and 7

DESCRIPTION		K & K WELL DRILLING	LAYNE WESTERN	MUNICIPAL WELL AND PUMP
SITE NO	LOCATION	COST	COST	COST
2	1220 PLAINFIELDS ROAD	\$ 16,600.00	\$ 21,551.00	\$ 31,890.00
5	1930 MANNING ROAD	\$ 13,350.00	\$ 16,136.00	\$ 26,120.00
7	LAKEVIEW DR-1000 YARDS WEST OF BAILEY	\$ 24,850.00	\$ 26,960.00	\$ 30,280.00
	TOTAL WELL COSTS	\$ 54,800.00	\$ 37,687.00	\$ 58,010.00
DETAIL SUMMARY				
	FYE 16 BUDGET	\$ 55,150.00		
	WELL 2, 5 AND 7 COST	\$ 54,800.00		
	BALANCE	\$ 350.00		

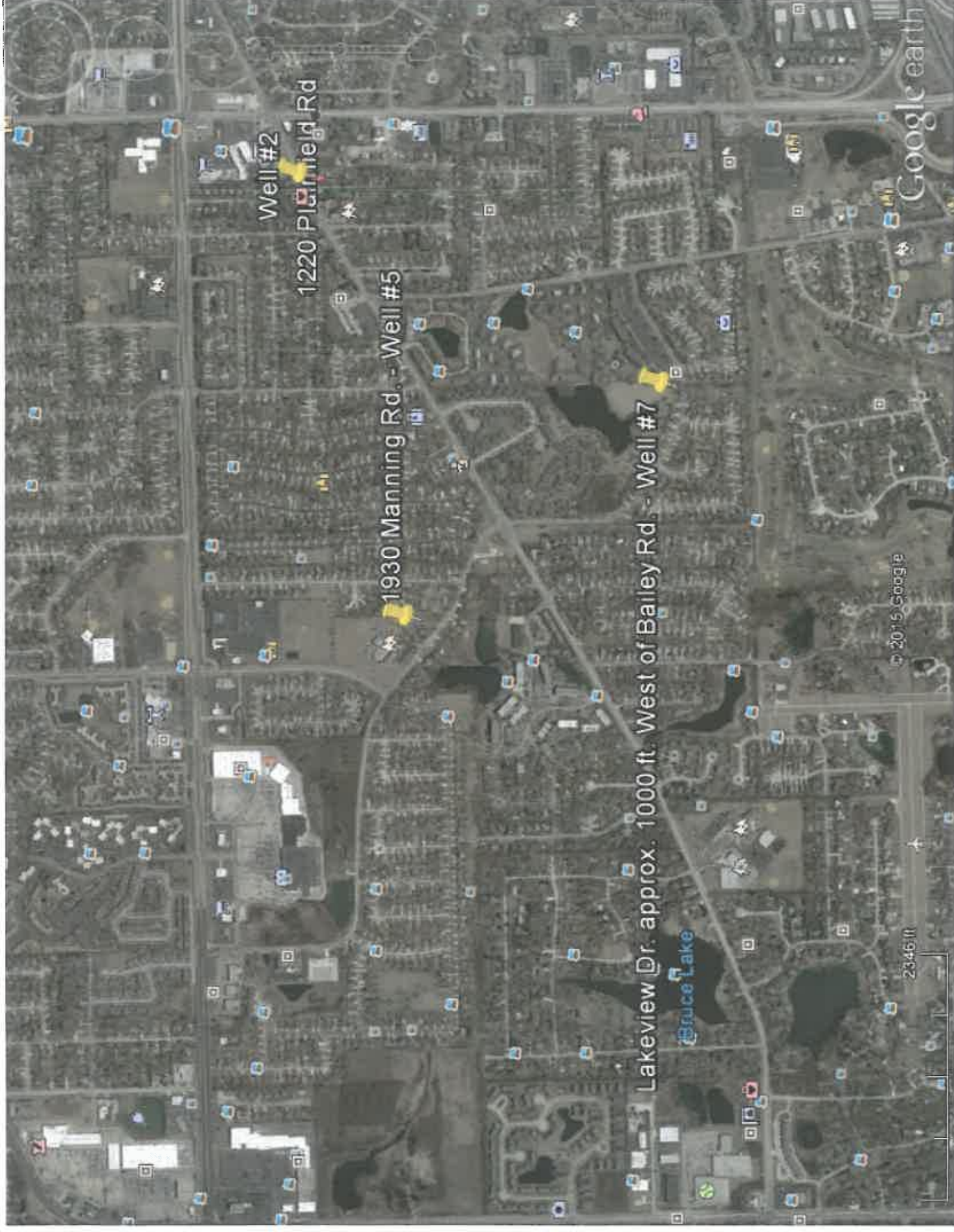

Well #2

1220 Plainfield Rd

1930 Manning Rd. - Well #5

Lakeview Dr. approx. 1000 ft. West of Bailey Rd. - Well #7

Bruce Lake

© 2015 Google

Google earth

2346 ft

RESOLUTION NO. _____

A RESOLUTION ACCEPTING A PROPOSAL FROM K&K WELL DRILLING IN THE AMOUNT OF \$54,800.00 FOR THE ABANDONMENT OF WELLS NO, 2, 5 AND 7

BE IT RESOLVED BY THE CITY COUNCIL OF THE CITY OF DARIEN, DU PAGE COUNTY, ILLINOIS, as follows:

SECTION 1: The City Council of the City of Darien hereby accepts a proposal from K&K Well Drilling in the Amount of \$54,800.00 for the abandonment of wells No. 2, 5 and 7, a copy of which is attached hereto as “**Exhibit A**” and is by this reference expressly incorporated herein.

SECTION 2: This Resolution shall be in full force and effect from and after its passage and approval as provided by law.

PASSED BY THE CITY COUNCIL OF THE CITY OF DARIEN, DU PAGE COUNTY, ILLINOIS, this 4th day of May, 2015.

AYES: _____

NAYS: _____

ABSENT: _____

APPROVED BY THE MAYOR OF THE CITY OF DARIEN, DU PAGE COUNTY, ILLINOIS this 4th day of May, 2015.

KATHLEEN MOESLE WEAVER, MAYOR

ATTEST:

JOANNE E. RAGONA, CITY CLERK

APPROVED AS TO FORM:

CITY ATTORNEY

PROPOSAL



Pump Sales & Service - Call For Estimates
 P.O. BOX 430
 YORKVILLE, IL 60560
 630-553-5111

TO: CITY OF DARIEN PUBLIC WORKS
1041 S. FRONTAGE
DARIEN, IL 60561
630.514.3453 KRIS THROM
PHONE FAX

RESPOND TO: K & K WELL DRILLING, INC.
P.O. BOX 430
YORKVILLE, IL 60560
630-553-5111 630-553-7494
PHONE FAX

THE UNDERSIGNED PROPOSES TO FURNISH ALL MATERIALS AND PERFORM ALL LABOR NECESSARY TO COMPLETE THE FOLLOWING:

JOB LOCATION: 1220 PLAINFIELD ROAD, DARIEN, IL

LEGAL DESCRIPTION: _____

SCOPE OF WORK: PERMANENTLY ABANDON EXISTING 15" WATER WELL

CRANE RENTAL / LABOR CHARGE TO PULL ESTIMATED 273' OF 5" 7/C LINE PIPE	5,900.00
RUN DOWN HOLE CAMERA TO VALIDATE CASING & WELL DEPTH FOR SEALING	500.00
PERMANENTLY ABANDON EXISTING ESTIMATED 317' 15" WELL	9,950.00
DUPAGE COUNTY WELL SEALING PERMIT / AFFIDAVIT PREPARATION FEE	250.00

PULLING CHARGE BEYOND 273' LINE PIPE BILLED AT \$856 PER HOUR
 ABANDONMENT CHARGE BEYOND 317' OF 15" HOLE BILLED AT \$40 PER FOOT

*** PRICE INDICATIVE OF HAULING OFF & DISPOSING OF ALL PUMP MATERIALS ***

Total Proposed Cost \$ 16,600.00

TERMS: zero DOWN PAYMENT UPON ACCEPTANCE, BALANCE TO BE PAID UPON COMPLETION OF WORK. PROPOSAL PRICE GOOD FOR 30 DAYS.

RESPECTFULLY SUBMITTED, K & K WELL DRILLING, INC

DATE APRIL 13, 2015

SIGNATURE 

Ken Knierim

Acceptance

It is the property owner's responsibility to provide right of way access to the well location. It should be understood that the nature of drilling means heavy machinery moving into and on your yard. A certain amount of mess in the form of tire ruts, flow of water, drill mud, and rock chips from the drilling operation should be expected. If the pump installation requires trenching, this will affect the yard's appearance as well. K & K is not responsible for hauling offsite any excess dirt or drill spoils as the result of the installation as a whole. K & K is waived of any and all liability for any repairs or damage to yard, landscaping, underground private utilities or services *not located by J.U.L.I.E, Inc., or driveway as the result of work performed or acquiring access onto your property.* K & K is not responsible for neither quantity nor quality of water achieved in drilling process. Labor is guaranteed for 30 days. A finance charge of 1.5 % per month, an annual percentage rate of 18 %, will be added to delinquent accounts. K & K is hereby authorized to furnish all materials and labor required to complete the work mentioned in the above proposal, for which the undersigned assumes a personal guarantee to pay the amount mentioned in said proposal, and according to the terms thereof. Should contractor bring suit in court to enforce any terms of the contract, owner or acceptor of this proposal shall pay to K & K its costs, expenses, and reasonable attorney fees. The parties consent to the sole and exclusive jurisdiction in the State of Illinois, County of Kendall, for any claims or disputes between parties. The parties further agree that any claims or disputes shall be governed by the laws of the State of Illinois. In the event K & K is found to have liability to Customer in connection with this agreement, the parties agree K & K's liability to Customer shall not exceed the amount Customer has paid pursuant to this contract. Upon signature, this document becomes a binding contract upon both parties.

Signature: _____

Date Accepted: _____ Print Name: _____

PROPOSAL



Pump Sales & Service - Call For Estimates
P.O. BOX 430
YORKVILLE, IL 60560
630-553-5111

TO: CITY OF DARIEN PUBLIC WORKS
1041 S. FRONTAGE
DARIEN, IL 60561
630.514.3453 KRIS THROM
PHONE FAX

RESPOND TO: K & K WELL DRILLING, INC.
P.O. BOX 430
YORKVILLE, IL 60560
630-553-5111 630-553-7494
PHONE FAX

THE UNDERSIGNED PROPOSES TO FURNISH ALL MATERIALS AND PERFORM ALL LABOR NECESSARY TO COMPLETE THE FOLLOWING:

JOB LOCATION: 1930 MANNING ROAD, DARIEN, IL

LEGAL DESCRIPTION: _____

SCOPE OF WORK: PERMANENTLY ABANDON EXISTING 10" WATER WELL

CRANE RENTAL / LABOR CHARGE TO PULL ESTIMATED 200' OF 6" T/C LINE PIPE	5,400.00
RUN DOWN HOLE CAMERA TO VALIDATE CASING & WELL DEPTH FOR WELL SEALING	500.00
PERMANENTLY ABANDON EXISTING ESTIMATED 320' 10" WELL	7,200.00
DUPAGE COUNTY WELL SEALING PERMIT / AFFIDAVIT PREPARATION FEE	250.00

PULLING CHARGE BEYOND 200' LINE PIPE BILLED AT \$850 PER HOUR
ABANDONMENT CHARGE BEYOND 317' OF 15" HOLE BILLED AT \$27 PER FOOT

*** PRICE INDICATIVE OF HAULING OFF & DISPOSING OF ALL PUMP MATERIALS ***

Total Proposed Cost \$ 13,350.00

TERMS: zero DOWN PAYMENT UPON ACCEPTANCE, BALANCE TO BE PAID UPON COMPLETION OF WORK. PROPOSAL PRICE GOOD FOR 30 DAYS.

RESPECTFULLY SUBMITTED, K & K WELL DRILLING, INC.

DATE APRIL 13, 2015

SIGNATURE 

Ken Knierim

Acceptance

It is the property owner's responsibility to provide right of way access to the well location. It should be understood that the nature of drilling means heavy machinery moving into and on your yard. A certain amount of mess in the form of tire ruts, flow of water, drill mud, and rock chips from the drilling operation should be expected. If the pump installation requires trenching, this will affect the yard's appearance as well. K & K is not responsible for hauling offsite any excess dirt or drill spoils as the result of the installation as a whole. K & K is waived of any and all liability for any repairs or damage to yard, landscaping, underground private utilities or services *not located by J.U.L.L.E, Inc., or driveway* as the result of work performed or acquiring access onto your property. K & K is not responsible for neither quantity nor quality of water achieved in drilling process. Labor is guaranteed for 30 days. A finance charge of 1.5 % per month, an annual percentage rate of 18 %, will be added to delinquent accounts. K & K is hereby authorized to furnish all materials and labor required to complete the work mentioned in the above proposal, for which the undersigned assumes a personal guarantee to pay the amount mentioned in said proposal, and according to the terms thereof. Should contractor bring suit in court to enforce any terms of the contract, owner or acceptor of this proposal shall pay to K & K its costs, expenses, and reasonable attorney fees. The parties consent to the sole and exclusive jurisdiction in the State of Illinois, County of Kendall, for any claims or disputes between parties. The parties further agree that any claims or disputes shall be governed by the laws of the State of Illinois. In the event K & K is found to have liability to Customer in connection with this agreement, the parties agree K & K's liability to Customer shall not exceed the amount Customer has paid pursuant to this contract. Upon signature, this document becomes a binding contract upon both parties.

Signature: _____

Date Accepted: _____ Print Name: _____

PROPOSAL

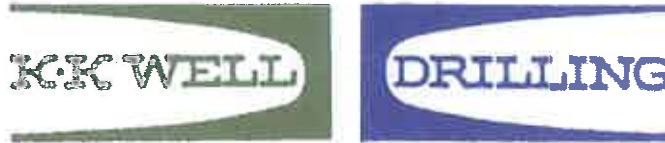

Pump Sales & Service - Call For Estimates
P.O. BOX 430
YORKVILLE, IL 60560
630-553-5111

TO: CITY OF DARIEN PUBLIC WORKS
1041 S. FRONTAGE
DARIEN, IL 60561
630.514.3453 KRIS THROM
PHONE FAX

RESPOND TO: K & K WELL DRILLING, INC.
P.O. BOX 430
YORKVILLE, IL 60560
630-553-5111 630-553-7494
PHONE FAX

THE UNDERSIGNED PROPOSES TO FURNISH ALL MATERIALS AND PERFORM ALL LABOR NECESSARY TO COMPLETE THE FOLLOWING:

JOB LOCATION: WELL # 7

LEGAL DESCRIPTION: _____

SCOPE OF WORK: PERMANENTLY ABANDON EXISTING 20" WATER WELL

CRANE RENTAL / LABOR CHARGE TO PULL ESTIMATED 222' OF 8.75" T/C LINE PIPE	8,500.00
RUN DOWN HOLE CAMERA TO VALIDATE CASING & WELL DEPTH FOR SEALING	500.00
PERMANENTLY ABANDON EXISTING ESTIMATED 356' 20" WELL	15,600.00
DUPAGE COUNTY WELL SEALING PERMIT / AFFIDAVIT PREPARATION FEE	250.00

PULLING CHARGE BEYOND 222' LINE PIPE BILLED AT \$850 PER HOUR
ABANDONMENT CHARGE BEYOND 356' OF 20" HOLE BILLED AT \$45 PER FOOT

*** PRICE INDICATIVE OF HAULING OFF & DISPOSING OF ALL PUMP MATERIALS ***

Total Proposed Cost \$ 24,850.00

TERMS: zero DOWN PAYMENT UPON ACCEPTANCE, BALANCE TO BE PAID UPON COMPLETION OF WORK. PROPOSAL PRICE GOOD FOR 30 DAYS.

RESPECTFULLY SUBMITTED, K & K WELL DRILLING, INC

DATE APRIL 13, 2015

SIGNATURE 

Ken Knierim

Acceptance

It is the property owner's responsibility to provide right of way access to the well location. It should be understood that the nature of drilling means heavy machinery moving into and on your yard. A certain amount of mess in the form of tire ruts, flow of water, drill mud, and rock chips from the drilling operation should be expected. If the pump installation requires trenching, this will effect the yard's appearance as well. K & K is not responsible for hauling offsite any excess dirt or drill spoils as the result of the installation as a whole. K & K is waived of any and all liability for any repairs or damage to yard, landscaping, underground private utilities or services not located by J.U.L.L.E, Inc., or driveway as the result of work performed or acquiring access onto your property. K & K is not responsible for neither quantity nor quality of water achieved in drilling process. Labor is guaranteed for 30 days. A finance charge of 1.5 % per month, an annual percentage rate of 18 %, will be added to delinquent accounts. K & K is hereby authorized to furnish all materials and labor required to complete the work mentioned in the above proposal, for which the undersigned assumes a personal guarantee to pay the amount mentioned in said proposal, and according to the terms thereof. Should contractor bring suit in court to enforce any terms of the contract, owner or acceptor of this proposal shall pay to K & K its costs, expenses, and reasonable attorney fees. The parties consent to the sole and exclusive jurisdiction in the State of Illinois, County of Kendall, for any claims or disputes between parties. The parties further agree that any claims or disputes shall be governed by the laws of the State of Illinois. In the event K & K is found to have liability to Customer in connection with this agreement, the parties agree K & K's liability to Customer shall not exceed the amount Customer has paid pursuant to this contract. Upon signature, this document becomes a binding contract upon both parties.

Signature: _____

Date Accepted: _____ Print Name: _____

AGENDA MEMO
Municipal Services Committee
April 27, 2015

Issue Statement

Consideration for the authorization to execute an Illinois Department of Transportation Resolution, (IDOT BLR 14230) authorizing the expenditure of Motor Fuel Tax (MFT) funds for the FY 2015/16 General Maintenance items in the amount of \$614,915 for a period from May 1, 2015 through April 30, 2016.

Background/History

The City of Darien utilizes Motor Fuel Tax Funds (MFT) for expenditures related to various street maintenance functions. The funding provides for expenditures for such items as salaries, the purchase of rock salt, cold and hot bituminous surface mixes, storm sewer related items, various aggregate materials and road striping. Because MFT funds are utilized, the City Council is required to adopt a resolution authorizing the expenditure of the proposed funding related to the general maintenance items. Attached as, Attachment A is the Bureau of Local Road Forms Municipal Estimate of Maintenance Costs and Request for Expenditure/Authorization of Motor Fuel Tax Funds (BLR 14231 and BLR09150).

Staff Recommendation

Staff recommends approval of this Resolution.

Alternate Consideration

Not approving the Resolution.

DECISION MODE

This item will be placed on the May 4, 2015 City Council agenda for formal consideration.



CITY OF DARIEN

In the County of DuPage and the State of Illinois
Incorporated 1969

May 4, 2015

Mr. John Fortman, P.E.
Deputy Director of Highways,
Region One Engineer
Division of Highways/Region One/District One
201 West Center Ct.
Schaumburg, IL 60196-1096

RE: Section Number 16-00000-00-RF

Dear Mr. Fortman:

In accordance with the Bureau of Local Roads and Streets Administrative Policy Manual, the following is an estimate of the allotted MFT monies to spend by the City during the Fiscal Year ending April 30, 2016.

Estimated Total Expenditures for:

FICA	\$ 18,600
IMRF	\$ 44,490
MEDICARE	\$ 4,350
TOTAL	\$ 67,440

If you have any questions regarding this matter, please contact Dan Gombac, Director of Municipal Services at dgombac@darienil.gov or via telephone at 630-353-8106.

Sincerely,
CITY OF DARIEN

Daniel Gombac
Director of Municipal Services

cc: Bryon Vana, City Administrator
Paul Nosek, City Assistant Administrator
Marie Kyriakoulis, City Accountant



Resolution for Maintenance of Streets and Highways by Municipality Under the Illinois Highway Code

BE IT RESOLVED, by the City Council of the City of Darien, Illinois, that there is hereby appropriated the sum of \$614,915.00 of Motor Fuel Tax funds for the purpose of maintaining streets and highways under the applicable provisions of the Illinois Highway Code from May 1, 2015 to April 30, 2016

BE IT FURTHER RESOLVED, that only those streets, highways, and operations as listed and described on the approved Municipal Estimate of Maintenance Costs, including supplemental or revised estimates approved in connection with this resolution, are eligible for maintenance with Motor Fuel Tax funds during the period as specified above.

BE IT FURTHER RESOLVED, that the Clerk shall, as soon a practicable after the close of the period as given above, submit to the Department of Transportation, on forms furnished by said Department, a certified statement showing expenditures from and balances remaining in the account(s) for this period; and

BE IT FURTHER RESOLVED, that the Clerk shall immediately transmit two certified copies of this resolution to the district office of the Department of Transportation, at Schaumburg, Illinois.

I, JoAnne E. Ragona Clerk in and for the City of Darien, County of DuPage

hereby certify the foregoing to be a true, perfect and complete copy of a resolution adopted by the City Council at a meeting on May 4, 2015

IN TESTIMONY WHEREOF, I have hereunto set my hand and seal this 4th day of May, 2015

(SEAL) City Clerk

Approved
Regional Engineer
Department of Transportation
Date



**Request for
Expenditure/Authorization
of Motor Fuel Tax Funds**

For District Use Only
Transaction Number _____
Date _____
Checked by _____

Municipality City of Darien

County DuPage

Rd. District _____

Section 16-00000-00-RF

I hereby request authorization to expend Motor Fuel Tax Funds as indicated below.

Purpose	Amount
Contract Construction	_____
Day Labor Construction	_____
Right-of-Way (Itemized On Reverse Side)	_____
Engineering.....	_____
Maintenance Engineering.....	_____
Engineering Investigations.....	_____
Other Category	_____
Obligation Retirement.....	_____
Maintenance	_____
Co. Eng./Supt. Salary & (Period _____ to _____)	_____
IMRF or Social Security	50,000.00
Interest _____	_____
_____	_____
_____	_____
Total	\$ 50,000.00

Comments _____

Date May, 4 2015

Signed by _____

Director of Municipal Services
Title of Official

Approved

Date
Department of Transportation

Regional Engineer

Itemization of Right-of-Way Request

Location of Property			Name of Owner	Acres Right- of-Way	Cost of Land Taken	Cost of Damage to Land Not Taken	Total
Street	Between (Street)	And (Street)					
						Total \$	

AGENDA MEMO
Municipal Services Committee
April 27, 2015

ISSUE STATEMENT

Approval of a resolution authorizing the Mayor to execute an Intergovernmental Agreement with the County of DuPage for the purpose of sharing costs for design and construction engineering, IDOT Letting and Construction for the Street Lighting Project within limited locations of the 75th Street Corridor and the Cass Avenue Corridor in an amount not to exceed \$278,003.10.

BACKGROUND/HISTORY

The City of Darien has jointly succeeded with the County of DuPage in securing an extension of the CMAQ funding for the 75th Street Reconstruction Project as it relates to the replacement of street lighting along certain segments of 75th Street and along Cass Avenue, see attached plan labeled as Attachment A. Please recall 30 street light poles were removed as part of the reconstruction project. The street lights are owned and were installed by the City in the 80's and per the Intergovernmental Agreement on file. The County was not required to replace the street lighting. The CMAQ funding allows for the replacement lighting, in kind, design construction and construction engineering at a local match of 20%. The City Council also recently authorized theme lighting at specific locations within the 75th Street and Cass Avenue corridors. The theme lighting is not grant eligible and will be funded by the City 100%.

In summary the scope of the project includes the following limits:

- 75th Street – Williams Street to Farmingdale Drive
- Cass Avenue - Plainfield Road to approximately 500 feet north of 75th Street
- Plainfield Road - East and West of Cass Avenue approximately 250 feet in each direction

and is further detailed on the attached Estimate of Cost sheets labeled as Attachment B1 and B2:

- Concrete pole foundations
- Conduit
- Electrical Wire
- Lighting Controller and appurtenances
- 19 Decorative single mast arms-with theme lighting
- 5 Decorative double mast arms-with theme lighting
- 13 Aluminum single mast arms-Utilizing the poles that were removed
- 5 Aluminum double mast arms-Utilizing the poles that were removed
- Restoration-Concrete, bituminous and landscaping
- Construction Layout
- Construction Engineering

75th Street-Cass Avenue Street Lighting Project

April 27, 2015

Page 2

The proposed time line allows for the engineering plans, IDOT Letting and construction to be completed by December 2015. Pending lead times for the fixtures and weather, the project may carry into Spring of 2016. Should the Project require completion in 2016, an additional Construction Engineering expense may be incurred in the amount approximately \$65,000 of which the City would be responsible for \$21,450.

Attachment C is the 75th Street Corridor and Cass Avenue Corridor Cost Summary. Since the budgeting of this item, DuPage County's engineering consultant for the project has updated the cost schedule and pricing for the fixtures has increased, see attached e-mail labeled as Attachment D. Pending the bid results, staff will bring this item back to the City Council should the **Construction Cost** exceed the City Share in the amount of \$218,345. The **Construction Engineering Cost** is estimated not to exceed a City Share of \$33,000. A contingency in the amount of \$21,450 for **Winter Construction Engineering** is included in the event that the Project will carry into Spring of 2016. The total cost shall not exceed \$278,003.10.

Upon completion of the Project, the City will own and maintain the Street Lights per the conditions of the Permit labeled as Exhibit B.

Attached is a copy of the Intergovernmental Agreement (IGA) with DuPage County for the Plainfield Road Project, see Exhibit A.

The Street Lighting Project would be funded from the following line item:

ACCOUNT NUMBER	ACCOUNT DESCRIPTION	FY 15-16 BUDGET	PROPOSED EXPENDITURE	PROPOSED BALANCE
25-35-4390	75 th Street Lighting Project	\$ 238,000	\$ 256,553.10	(\$18,553.10)
25-35-4390	75 th Street Lighting Project CONTINGENCY WINTER ENGINEERING	N/A	\$ 21,450.00	(\$21,450.00)
TOTALS		\$ 238,000	\$ 278,003.10	(\$40,003.10)

Pending bid results, product lead times and weather conditions, the Project could be \$40,003.10 over budget. The Capital Account fund balance would be in a position to absorb the cost if necessary.

STAFF RECOMMENDATION

Approval of a resolution authorizing the execution of an Intergovernmental Agreement with the County of DuPage for the purpose of sharing costs for design and construction engineering, IDOT Letting and Construction for the Street Lighting Project within limited locations of the 75th Street Corridor and the Cass Avenue Corridor in an amount not to exceed \$278,003.10.

ALTERNATE CONSIDERATION

As directed.

DECISION MODE

This item will be forwarded to City Council on May 4, 2015 for formal approval.

F.A.P. RTE.	SECTION	COUNTY	TOTAL SHEETS	SHEET NO.
0369	15-00233-07-LT	DU PAGE	29	1
		ILLINOIS	CONTRACT NO.	

Attachment A



PROJECT LOCATED IN CITY OF DARIEN

STATE OF ILLINOIS
DEPARTMENT OF TRANSPORTATION
DIVISION OF HIGHWAYS

**PLANS FOR PROPOSED
FEDERAL AID HIGHWAY**

F.A.P. ROUTE 0369 (75th STREET / CH33):
ADAMS STREET TO PLAINFIELD ROAD
LIGHT POLE INSTALLATION AND ENHANCEMENTS
SECTION 15-00233-07-LT
PROJECT NO.
COUNTY OF DuPAGE

FOR INDEX OF SHEETS, SEE SHEET NO. 2

Preliminary Plans Not for Review

DESIGN DESIGNATION

75th STREET - OTHER PRINCIPAL ARTERIAL
(STRATEGIC REGIONAL ARTERIAL)
DESIGN SPEED: 75th STREET = 45 MPH (45 MPH POSTED)
CASS AVENUE = 45 MPH (40 MPH POSTED)
PLAINFIELD ROAD = 45 MPH (40 MPH POSTED)
2030 ADT: 75th STREET = 31,000
CASS AVENUE = 27,000
PLAINFIELD ROAD = 24,000

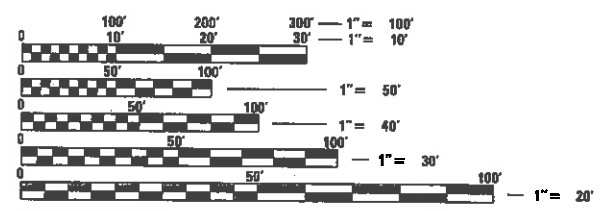

FULL SIZE PLANS HAVE BEEN PREPARED USING STANDARD ENGINEERING SCALES. REDUCED SIZED PLANS WILL NOT CONFORM TO STANDARD SCALES. IN MAKING MEASUREMENTS ON REDUCED PLANS, THE ABOVE SCALES MAY BE USED.

J.U.L.I.E.
JOINT UTILITY LOCATION INFORMATION FOR EXCAVATION
1-800-892-0123
OR 811

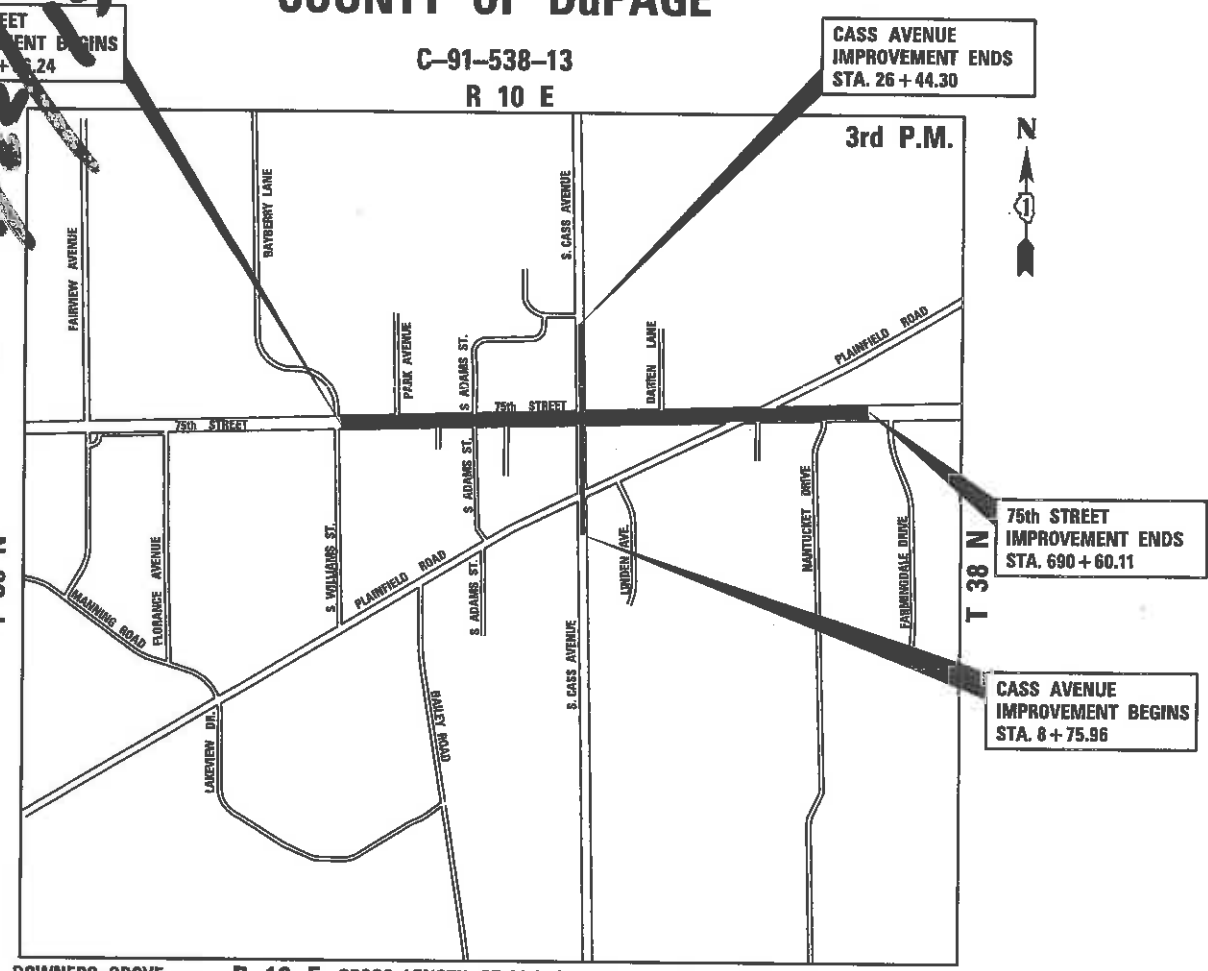

DOWNERS GROVE TOWNSHIP R 10 E
GROSS LENGTH OF 75th STREET = 6,073.88 FT. = 1.1504 MILE
NET LENGTH OF 75th STREET = 6,073.88 FT. = 1.1504 MILE
GROSS LENGTH OF PLAINFIELD ROAD = 2,962.71 FT. = 0.5611 MILE
NET LENGTH OF PLAINFIELD ROAD = 2,962.71 FT. = 0.5611 MILE
GROSS LENGTH OF CASS AVENUE = 1,768.11 FT. = 0.3349 MILE
NET LENGTH OF CASS AVENUE = 1,768.11 FT. = 0.3349 MILE
PROJECT TOTAL GROSS LENGTH = 10,804.70 FT. = 2.0463 MILE
PROJECT TOTAL NET LENGTH = 10,804.70 FT. = 2.0463 MILE

LOCATION MAP NOT TO SCALE

STATE OF ILLINOIS
DEPARTMENT OF TRANSPORTATION
DIVISION OF HIGHWAYS

SUBMITTED _____ 20 15 _____

_____ 20 _____
DU PAGE COUNTY ENGINEER

_____ 20 _____
DISTRICT ONE ENGINEER OF LOCAL ROADS AND STREETS

RELEASING FOR BID
BASED ON LIMITED
REVIEW _____ 20 15 _____

DEPUTY DIRECTOR OF HIGHWAYS, REGION ONE ENGINEER

**PRINTED BY THE AUTHORITY
OF THE STATE OF ILLINOIS**

PROGRAM AND OFFICE ENGINEER: CHARLES F. RIDDLE, P.E. 847-705-4406, SCHAUMBURG, IL

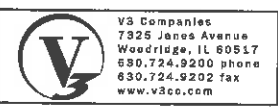

CONTRACT NO.

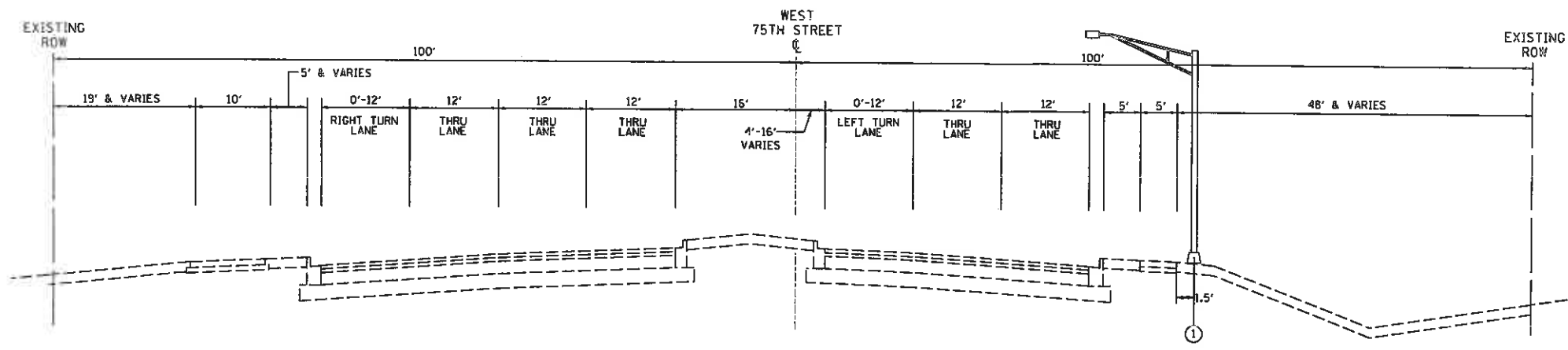

**PROPOSED TYPICAL SECTION NO. 1
75TH STREET**

STA 641+46.80 TO STA 644+73.55 (ADAMS STREET)

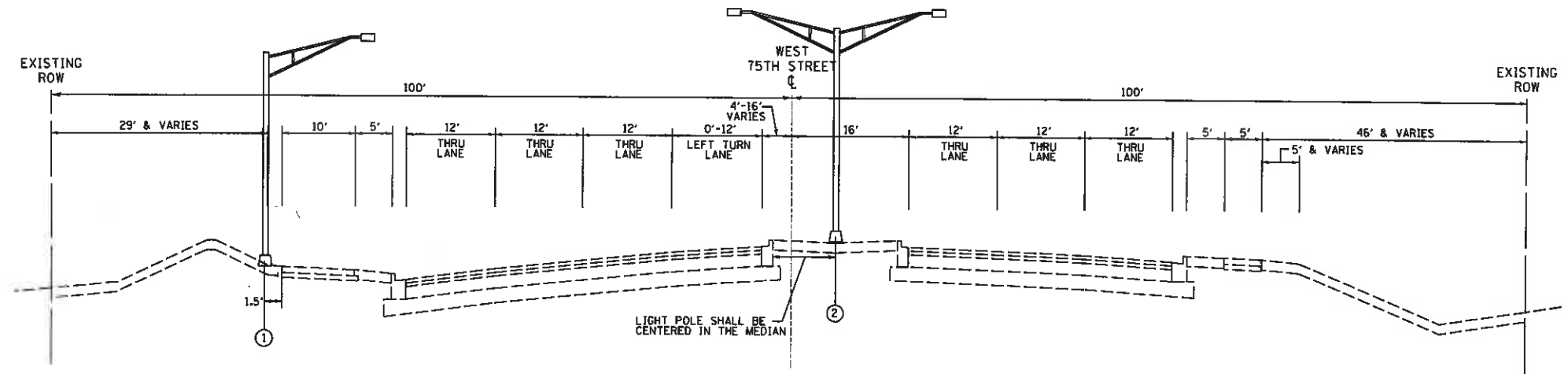

**PROPOSED TYPICAL SECTION NO. 2
75TH STREET**

STA 644+73.55 (ADAMS STREET) TO STA 649+39.96

LEGEND

- ① DARIEN PROVIDED LIGHT POLE AND 15' ARM, WITH NEW SINGLE L.E.D. ROADWAY LUMINAIRE, 47.5' MOUNTING HEIGHT.
- ② DARIEN PROVIDED LIGHT POLE AND 15' ARM, WITH NEW DOUBLE L.E.D. ROADWAY LUMINAIRE, 47.5' MOUNTING HEIGHT.
- ③ LIGHT POLE (ALUMINUM), DARK BRONZE POWDER COAT FINISH, WITH SINGLE L.E.D. ROADWAY LUMINAIRE, 47.5' MOUNTING HEIGHT, 15' MAST ARM DOUBLE L.E.D. DECORATIVE FIXTURE, 20' MOUNTING HEIGHT.
- ④ LIGHT POLE (ALUMINUM), DARK BRONZE POWDER COAT FINISH, WITH DOUBLE L.E.D. ROADWAY LUMINAIRE, 47.5' MOUNTING HEIGHT, 15' MAST ARM DOUBLE L.E.D. DECORATIVE FIXTURE, 20' MOUNTING HEIGHT.



USER NAME = jbour	DESIGNED - JDH	REVISED -
PLOT SCALE = 10,000' / in.	DRAWN - DRP	REVISED -
PLOT DATE = 3/10/2015	CHECKED - VJD	REVISED -
	DATE - 02/17/15	REVISED -

**STATE OF ILLINOIS
DEPARTMENT OF TRANSPORTATION**

PROPOSED TYPICAL SECTIONS - 75TH STREET

SCALE: 1"=10' SHEET NO. 1 OF 5 SHEETS

F.A.P. RTE.	SECTION	COUNTY	TOTAL SHEET SHEETS NO.
0369	15-00233-07-LT	DU PAGE	29 5
FED. ROAD DIST. NO. 1 ILLINOIS FED. AID PROJECT			CONTRACT NO.

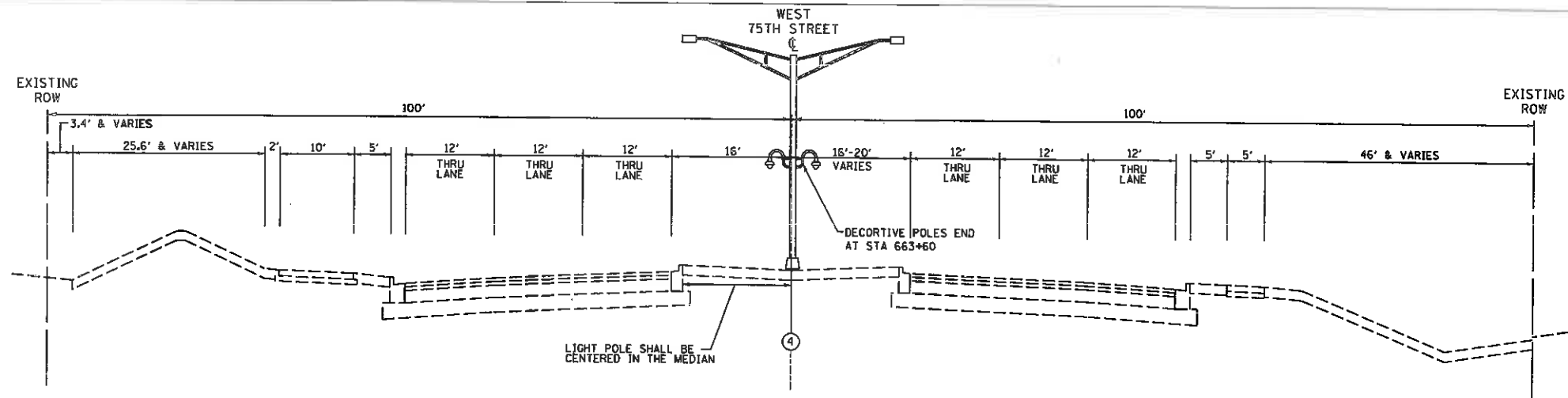

**PROPOSED TYPICAL SECTION NO. 3
75TH STREET**

STA 649+39.96 TO STA 652+00.00
STA 660+00.00 TO STA 668+80.00

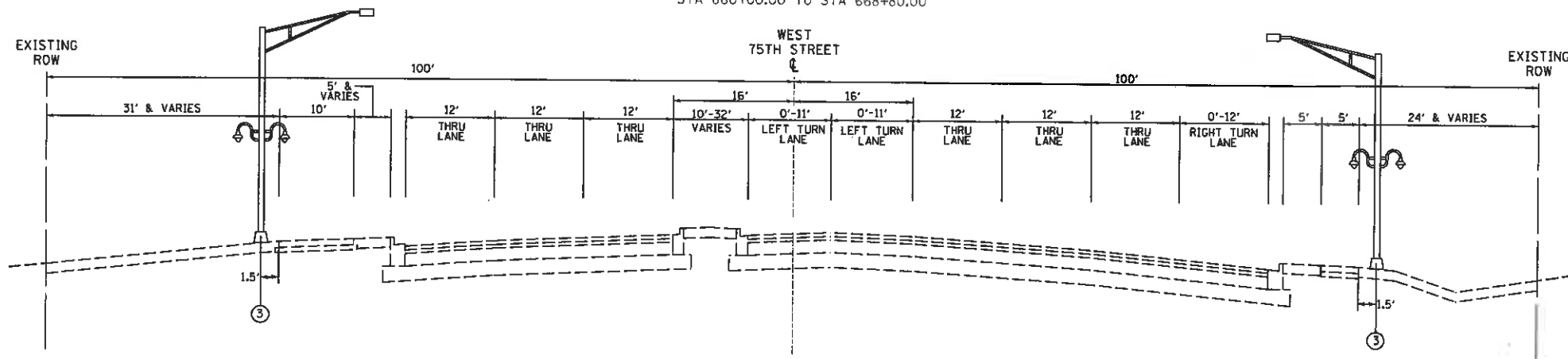

**PROPOSED TYPICAL SECTION NO. 4
75TH STREET**

STA 652+00.00 TO STA 656+22.96 (CASS AVE)

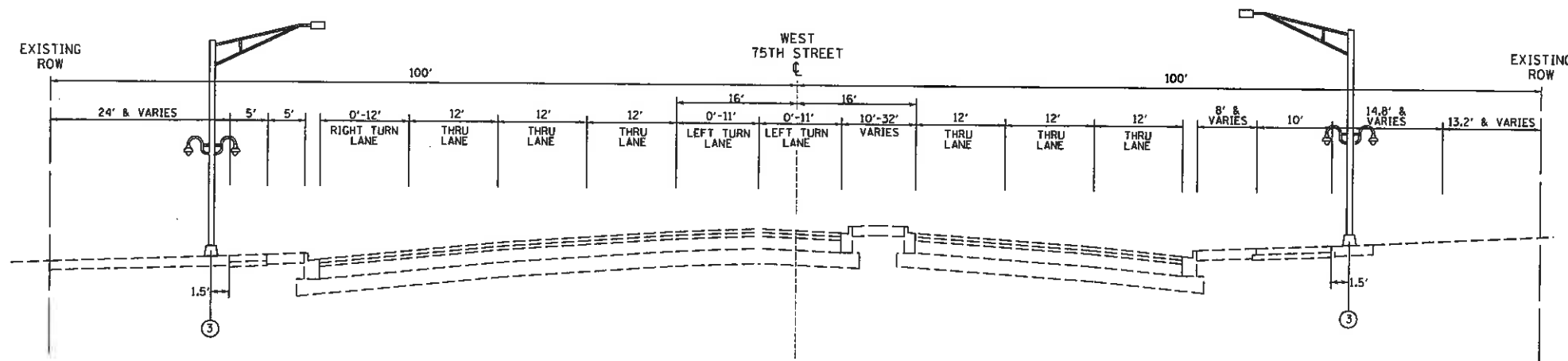

**PROPOSED TYPICAL SECTION NO. 5
75TH STREET**

STA 656+22.96 (CASS AVE) TO STA 660+00.00

LEGEND

- ① DARIEN PROVIDED LIGHT POLE AND 15' ARM, WITH NEW SINGLE L.E.D. ROADWAY LUMINAIRE, 47.5' MOUNTING HEIGHT.
- ② DARIEN PROVIDED LIGHT POLE AND 15' ARM, WITH NEW DOUBLE L.E.D. ROADWAY LUMINAIRE, 47.5' MOUNTING HEIGHT.
- ③ LIGHT POLE (ALUMINUM), DARK BRONZE POWDER COAT FINISH, WITH SINGLE L.E.D. ROADWAY LUMINAIRE, 47.5' MOUNTING HEIGHT, 15' MAST ARM DOUBLE L.E.D. DECORATIVE FIXTURE, 20' MOUNTING HEIGHT.
- ④ LIGHT POLE (ALUMINUM), DARK BRONZE POWDER COAT FINISH, WITH DOUBLE L.E.D. ROADWAY LUMINAIRE, 47.5' MOUNTING HEIGHT, 15' MAST ARM DOUBLE L.E.D. DECORATIVE FIXTURE, 20' MOUNTING HEIGHT.



USER NAME = jbauer
DESIGNED - JDH
DRAWN - DRP
CHECKED - VJD
DATE - 02/17/15

REVISOR -
REVISOR -
REVISOR -
REVISOR -

STATE OF ILLINOIS
DEPARTMENT OF TRANSPORTATION

PROPOSED TYPICAL SECTIONS - 75TH STREET

SCALE: 1"=10' SHEET NO. 2 OF 5 SHEETS STA. TO STA.

F.A.P. RTE.	SECTION	COUNTY	TOTAL SHEETS	SHEET NO.
0369	15-00233-07-LT	DU PAGE	29	6
FED. ROAD DIST. NO. 1 ILLINOIS FED. #111 PROJECT		CONTRACT NO.		

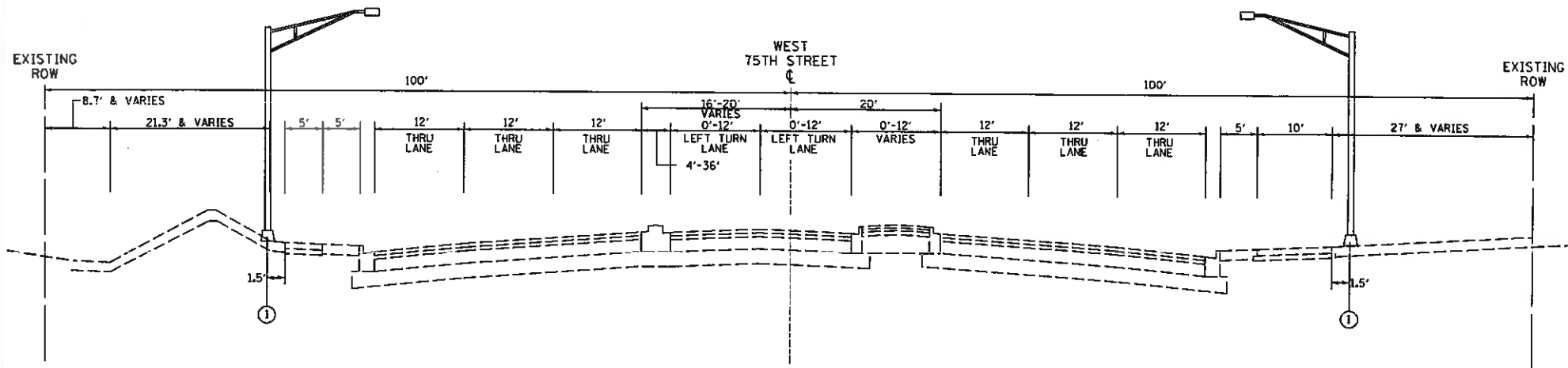

**PROPOSED TYPICAL SECTION NO. 6
75TH STREET**

STA 668+80.00 TO STA 674+55.14 (PLAINFIELD RD)

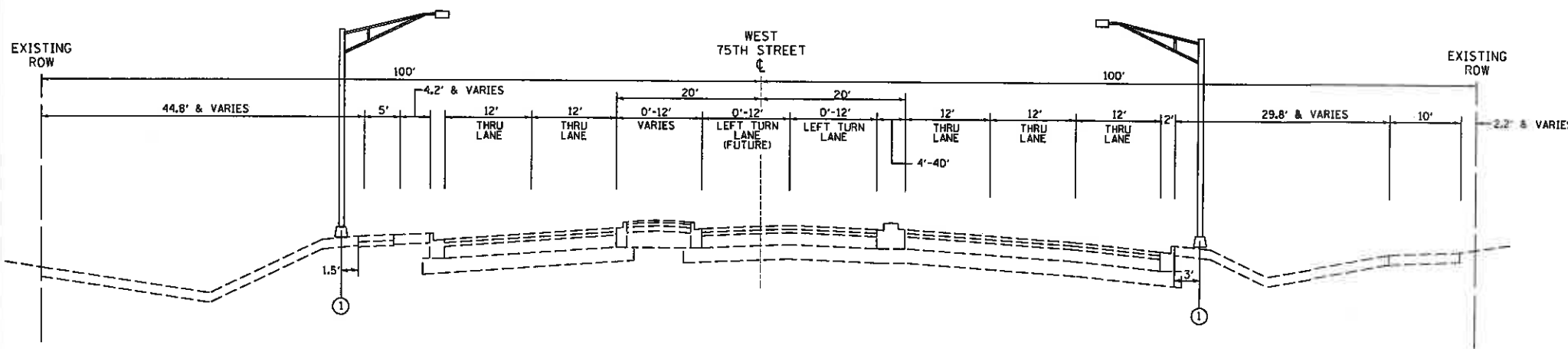

**PROPOSED TYPICAL SECTION NO. 7
75TH STREET**

STA 674+55.14 (PLAINFIELD RD) TO STA 684+00.00

LEGEND

- ① DARIEN PROVIDED LIGHT POLE AND 15' ARM, WITH NEW SINGLE L.E.D. ROADWAY LUMINAIRE, 47.5' MOUNTING HEIGHT.
- ② DARIEN PROVIDED LIGHT POLE AND 15' ARM, WITH NEW DOUBLE L.E.D. ROADWAY LUMINAIRE, 47.5' MOUNTING HEIGHT.
- ③ LIGHT POLE (ALUMINUM), DARK BRONZE POWDER COAT FINISH, WITH SINGLE L.E.D. ROADWAY LUMINAIRE, 47.5' MOUNTING HEIGHT, 15' MAST ARM DOUBLE L.E.D. DECORATIVE FIXTURE, 20' MOUNTING HEIGHT.
- ④ LIGHT POLE (ALUMINUM), DARK BRONZE POWDER COAT FINISH, WITH DOUBLE L.E.D. ROADWAY LUMINAIRE, 47.5' MOUNTING HEIGHT, 15' MAST ARM DOUBLE L.E.D. DECORATIVE FIXTURE, 20' MOUNTING HEIGHT.



USER NAME = jbauer	DESIGNED - JDH	REVISED - ---
PLOT SCALE = 10.0000' / 1"	DRAWN - DRP	REVISED - ---
PLOT DATE = 3/10/2015	CHECKED - VJD	REVISED - ---
	DATE - 02/17/15	REVISED - ---

**STATE OF ILLINOIS
DEPARTMENT OF TRANSPORTATION**

PROPOSED TYPICAL SECTIONS - 75TH STREET
SCALE: 1"=10'
SHEET NO. 3 OF 5 SHEETS STA. TO STA.

F.A.P. RTE.	SECTION	COUNTY	TOTAL SHEETS	SHEET NO.
0369	15-00233-07-LT		29	7
FED. ROAD DIST. NO. 1 ILLINOIS FED. AID PROJECT				

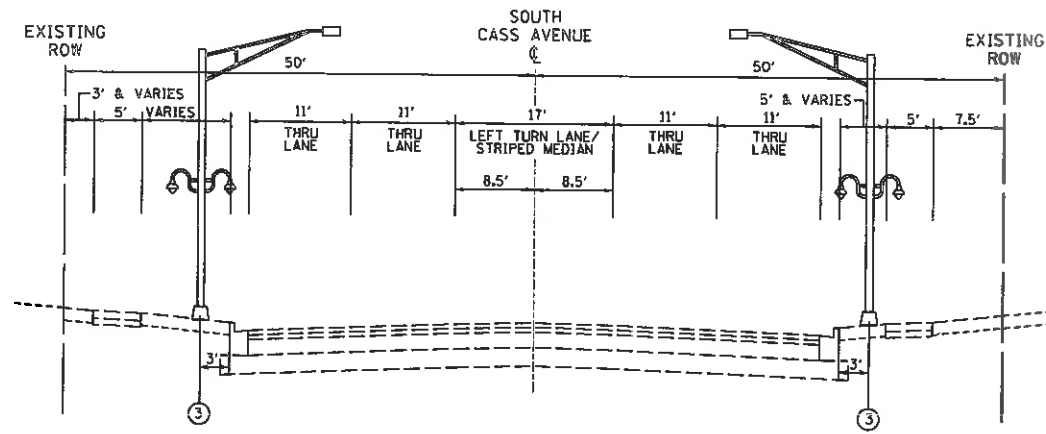

**PROPOSED TYPICAL SECTION NO. 1
CASS AVENUE**

STA 11+91.19 TO STA 16+83.46

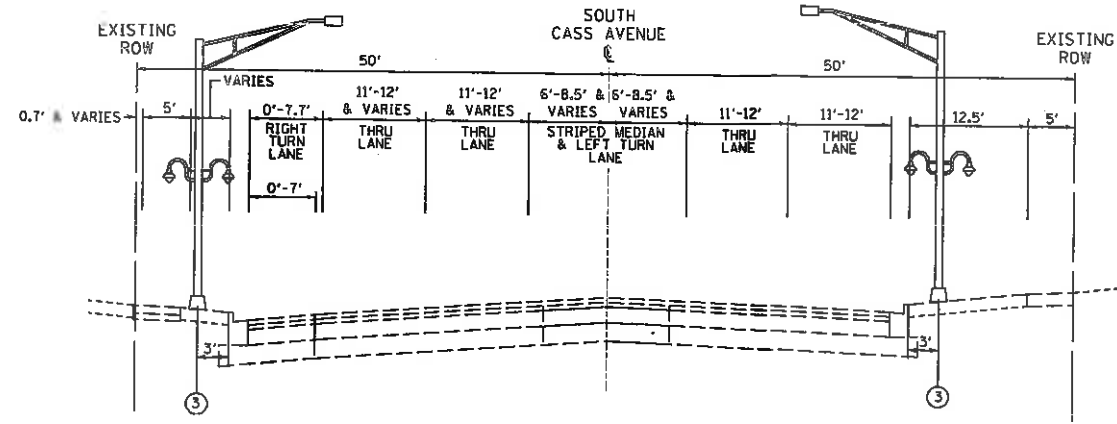

**PROPOSED TYPICAL SECTION NO. 6
CASS AVENUE**

STA 23+64.55 TO STA 25+00.00

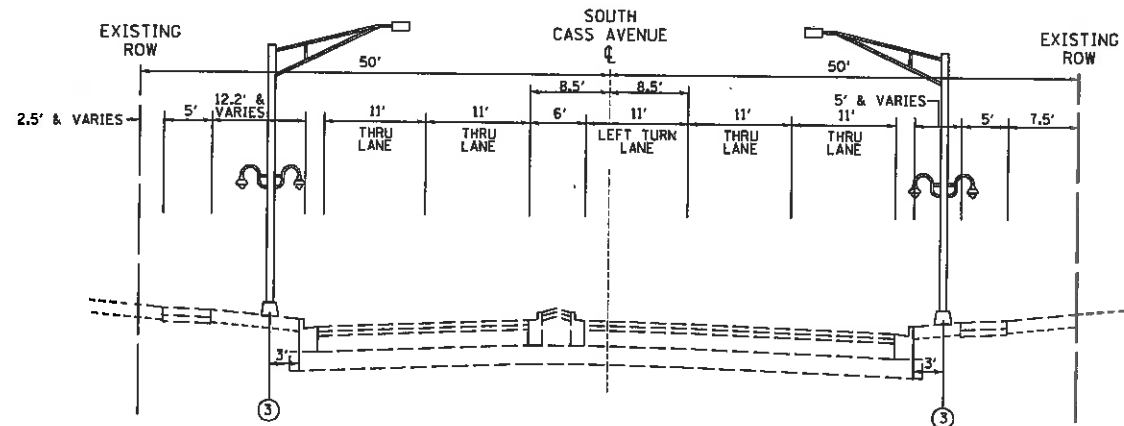

**PROPOSED TYPICAL SECTION NO. 3
CASS AVENUE**

STA 16+83.46 TO STA 19+99.92 (75TH ST)

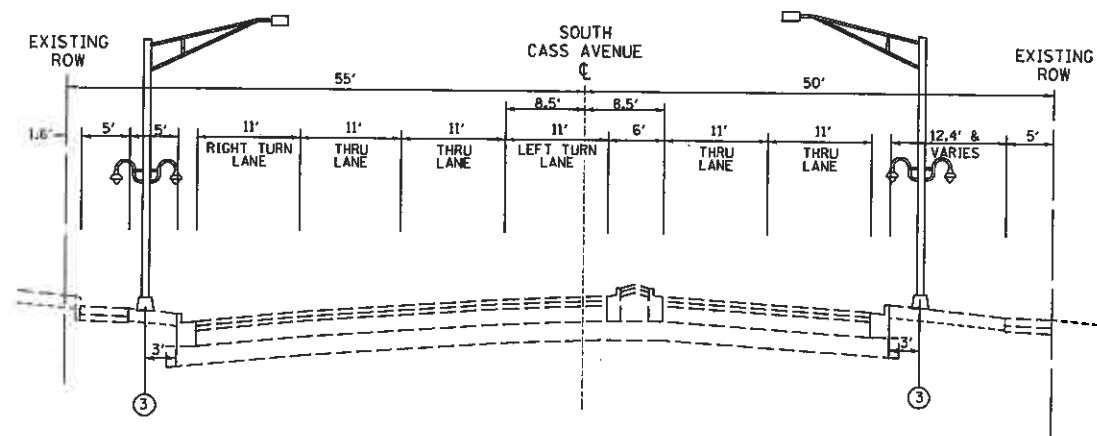

**PROPOSED TYPICAL SECTION NO. 4
CASS AVENUE**

STA 19+99.92 (75TH ST) TO STA 23+64.55

LEGEND

- ① DARIEN PROVIDED LIGHT POLE AND 15' ARM, WITH NEW SINGLE L.E.D. ROADWAY LUMINAIRE, 47.5' MOUNTING HEIGHT.
- ② DARIEN PROVIDED LIGHT POLE AND 15' ARM, WITH NEW DOUBLE L.E.D. ROADWAY LUMINAIRE, 47.5' MOUNTING HEIGHT.
- ③ LIGHT POLE (ALUMINUM), DARK BRONZE POWDER COAT FINISH, WITH SINGLE L.E.D. ROADWAY LUMINAIRE, 47.5' MOUNTING HEIGHT, 15' MAST ARM DOUBLE L.E.D. DECORATIVE FIXTURE, 20' MOUNTING HEIGHT.
- ④ LIGHT POLE (ALUMINUM), DARK BRONZE POWDER COAT FINISH, WITH DOUBLE L.E.D. ROADWAY LUMINAIRE, 47.5' MOUNTING HEIGHT, 15' MAST ARM DOUBLE L.E.D. DECORATIVE FIXTURE, 20' MOUNTING HEIGHT.



42 Springfield 1325 James Avenue Woodridge, IL 60517 630.724.4200 phone 630.724.4202 fax www.idot.com	USER NAME = jbauer	DESIGNED - JDH	REVISED -
	PLOT SCALE = 10,0000' / 1" =	DRAWN - DRP	REVISED -
	PLOT DATE = 3/10/2015	CHECKED - VJD	REVISED -
		DATE - 02/11/15	REVISED -

**STATE OF ILLINOIS
DEPARTMENT OF TRANSPORTATION**

PROPOSED TYPICAL SECTIONS - CASS AVENUE

SCALE: 1"=10' SHEET NO. 4 OF 5 SHEETS STA. TO STA.

F.A.P. RTE.	SECTION	COUNT	TOTAL SHEETS	SHEET NO.
0369	15-00233-07-LT		29	8
FED. ROAD DIST. NO. 1 ILLINOIS FED. AID PROJECT		CONTRACT NO.		

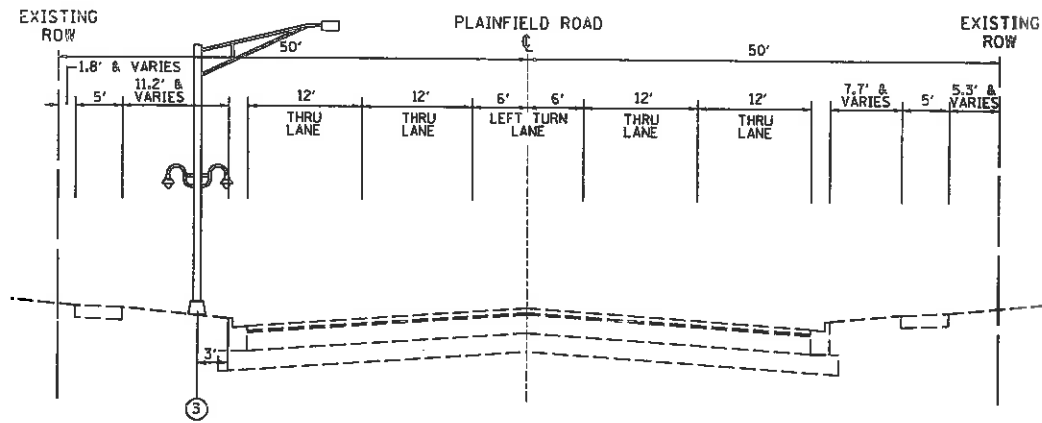

**PROPOSED TYPICAL SECTION NO. 1
PLAINFIELD ROAD**
STA 26+54.48 TO STA 29+69.05 (CASS AVE)

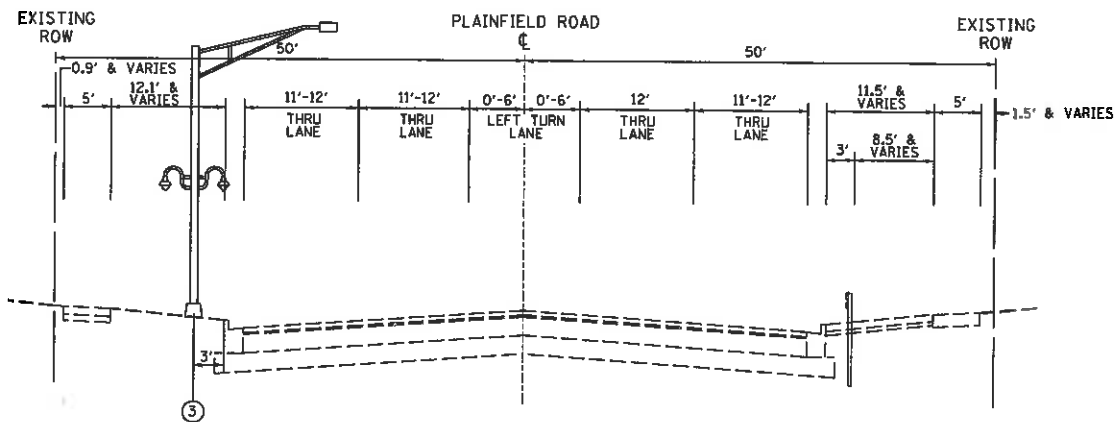

**PROPOSED TYPICAL SECTION NO. 2
PLAINFIELD ROAD**
STA 29+69.05 (CASS AVE) TO STA 39+52.35

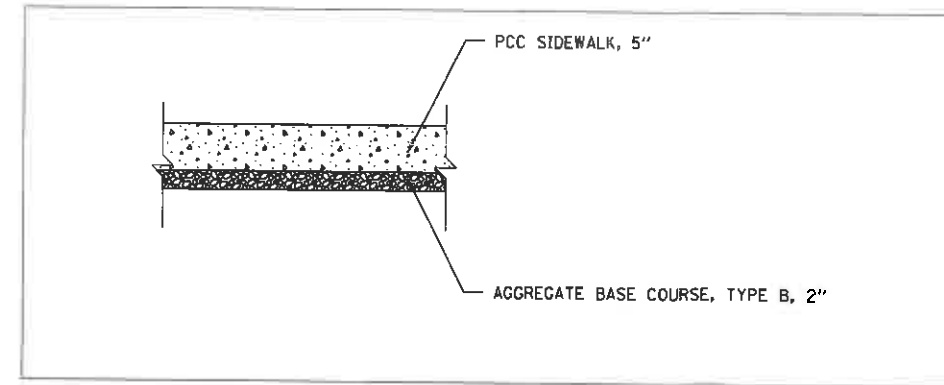

**PCC SIDEWALK
DETAIL**

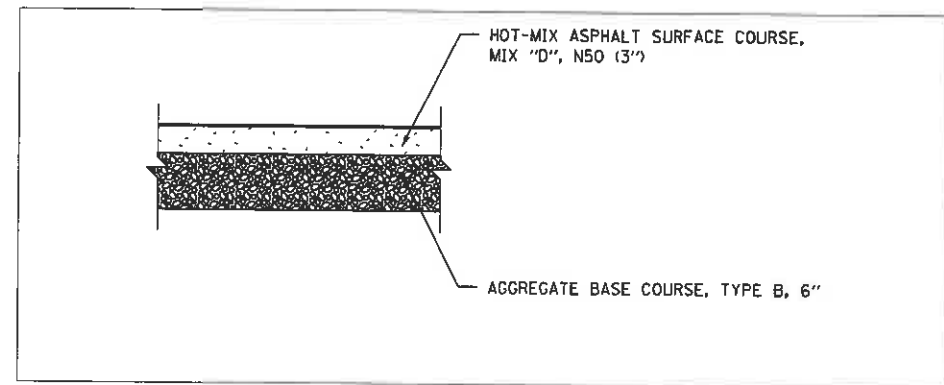

**MULTI USE PATH
DETAIL**

HMA NOTES:

- ① UNIT WEIGHT USED TO CALCULATE MOST HOT-MIX ASPHALT MIXTURES IS 112 LBS/SO YD/IN. FOR LEVELING BINDER USE 110 LBS/SO YD/IN.
- ② THE "AC TYPE" FOR POLYMERIZED HMA MIXES SHALL BE "SBS/SBR PG 76-22" AND FOR NON-POLYMERIZED HMA THE "AC TYPE" SHALL BE "PG 64-22" UNLESS MODIFIED BY DISTRICT ONE SPECIAL PROVISIONS. FOR "PERCENT OF RAP" SEE DISTRICT ONE SPECIAL PROVISIONS.

LEGEND

- ① DARIEN PROVIDED LIGHT POLE AND 15' ARM, WITH NEW SINGLE L.E.D. ROADWAY LUMINAIRE, 47.5' MOUNTING HEIGHT.
- ② DARIEN PROVIDED LIGHT POLE AND 15' ARM, WITH NEW DOUBLE L.E.D. ROADWAY LUMINAIRE, 47.5' MOUNTING HEIGHT.
- ③ LIGHT POLE (ALUMINUM), DARK BRONZE POWDER COAT FINISH, WITH SINGLE L.E.D. ROADWAY LUMINAIRE, 47.5' MOUNTING HEIGHT, 15' MAST ARM DOUBLE L.E.D. DECORATIVE FIXTURE, 20' MOUNTING HEIGHT.
- ④ LIGHT POLE (ALUMINUM), DARK BRONZE POWDER COAT FINISH, WITH DOUBLE L.E.D. ROADWAY LUMINAIRE, 47.5' MOUNTING HEIGHT, 15' MAST ARM DOUBLE L.E.D. DECORATIVE FIXTURE, 20' MOUNTING HEIGHT.

HOT-MIX ASPHALT REQUIREMENTS

MIXTURE TYPE	VOIDS
MULTI USE PATH	
HMA SURFACE COURSE, MIX "D", N50, 3"	4% @ 50 GYR



USER NAME = j_bauer	DESIGNED - JDH	REVISED - ---
PLOT SCALE = 10.0000' / 1"	DRAWN - DRP	REVISED - ---
PLOT DATE = 3/10/2015	CHECKED - VJD	REVISED - ---
	DATE - 02/17/15	REVISED - ---

**STATE OF ILLINOIS
DEPARTMENT OF TRANSPORTATION**

PROPOSED TYPICAL SECTIONS - PLAINFIELD ROAD

SCALE: 1"=10' SHEET NO. 5 OF 6 SHEETS STA. TO STA.

F.A.P. RTE.	SECTION	COUNTY	TOTAL SHEETS	SHEET NO.
0369	15-00233-07-LT		25	5
FED. ROAD DIST. NO. 1 ILLINOIS FED. AID PROJECT		CONTRACT NO.		

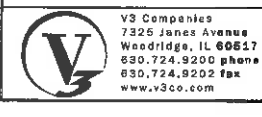
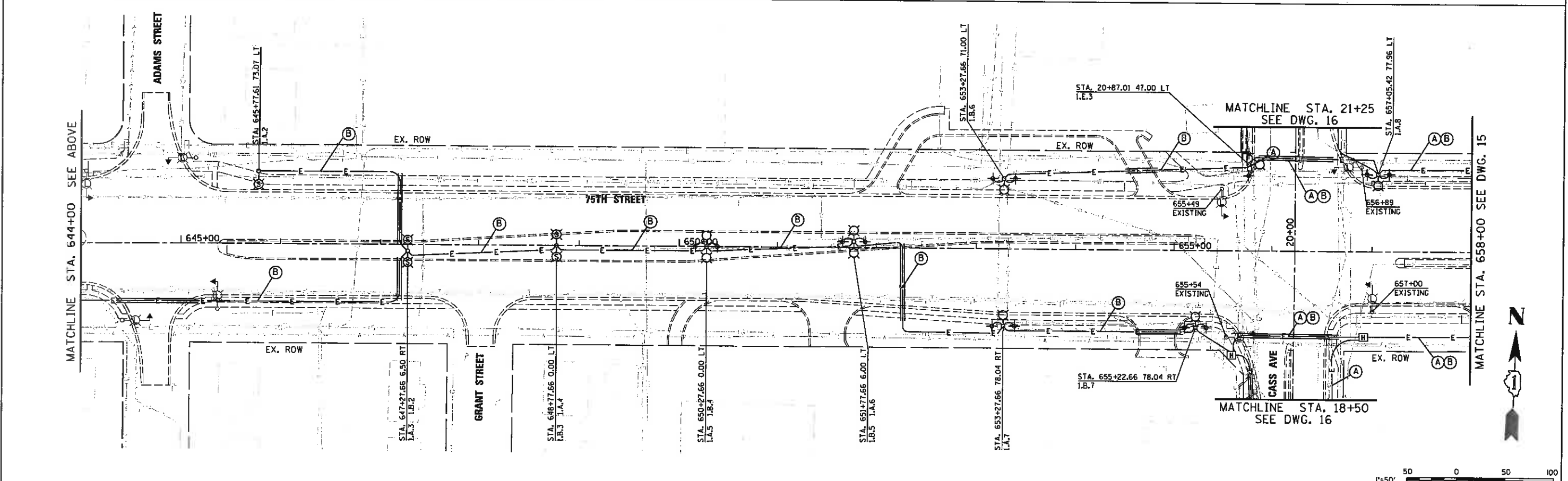
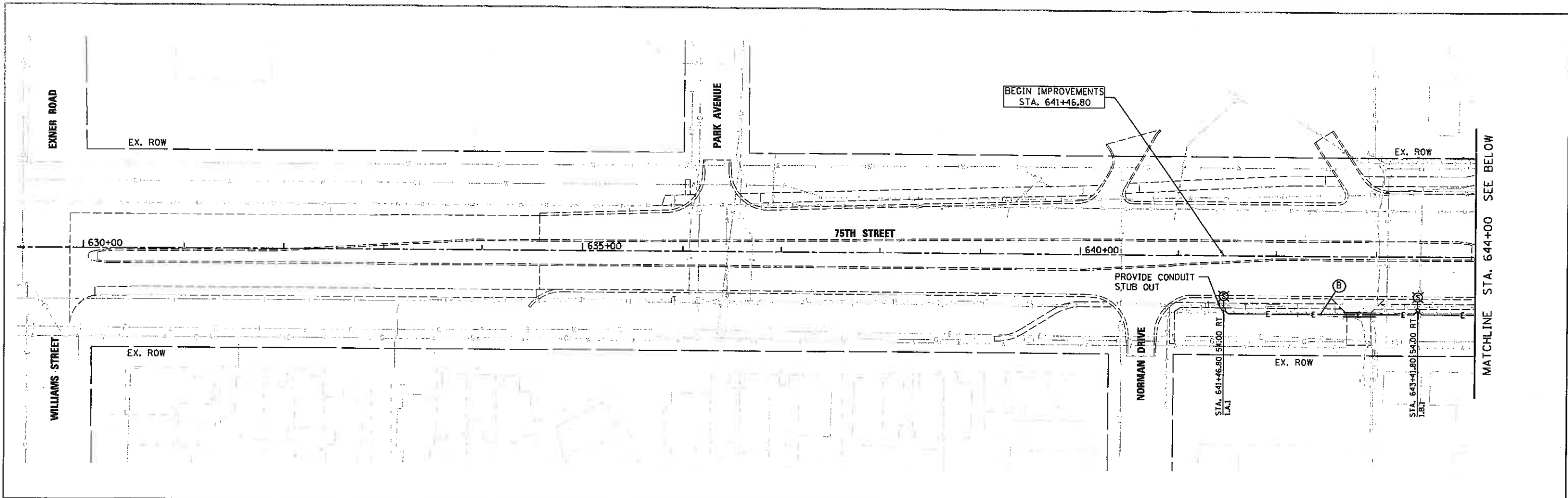

V3 Companies 7325 Janes Avenue Woodridge, IL 60617 830.724.9200 phone 830.724.9292 fax www.v3co.com	USER NAME = jbover	DESIGNED - JDH	REVISED -
	PLOT SCALE = 58.0000' / 1" =	DRAWN - DRP	REVISED -
	PLT DATE = 3/18/2015	CHECKED - VJD	REVISED -
		DATE - 02/17/15	REVISED -

STATE OF ILLINOIS
DEPARTMENT OF TRANSPORTATION

LIGHTING AND ELECTRICAL PLAN
75TH STREET
 SCALE: 1"=50' SHEET NO. 1 OF 3 SHEETS STA. 630+00 TO STA. 658+00

F.A.P. RTE.	SECTION	COUNTY	TOTAL SHEETS	SHEET NO.
D369	15-00233-07-LT	DU PAGE	29	13
FED. ROAD DIST. NO. 1		ILLINOIS FED. AID PROJECT		CONTRACT NO.

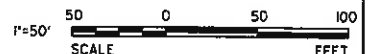

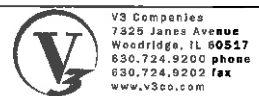
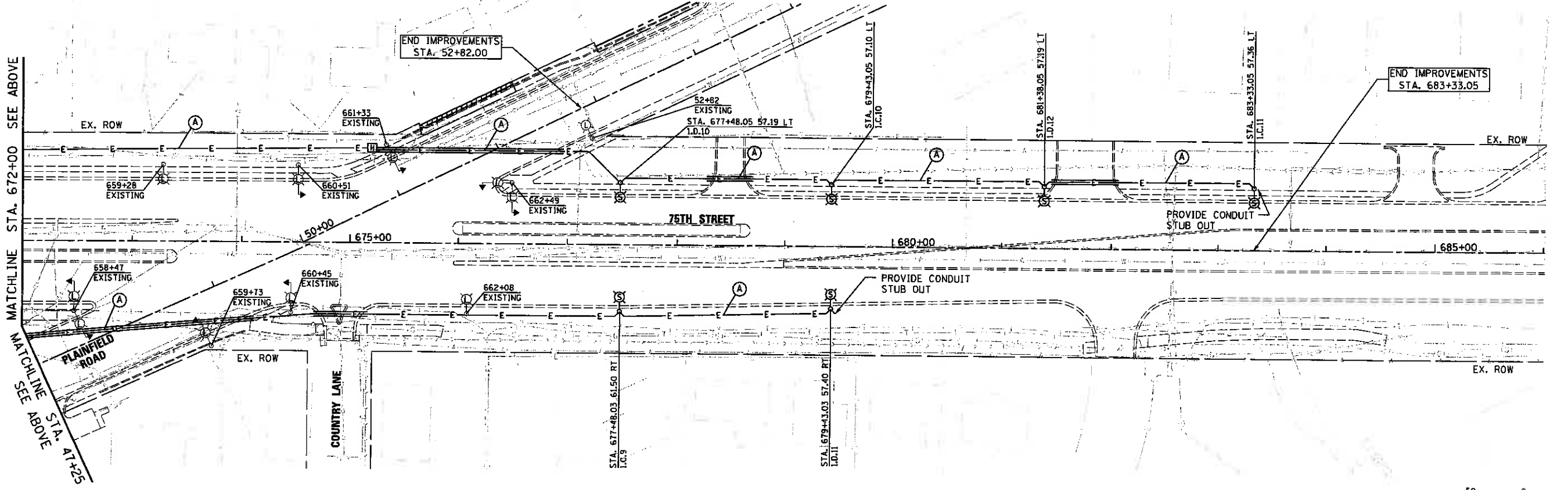
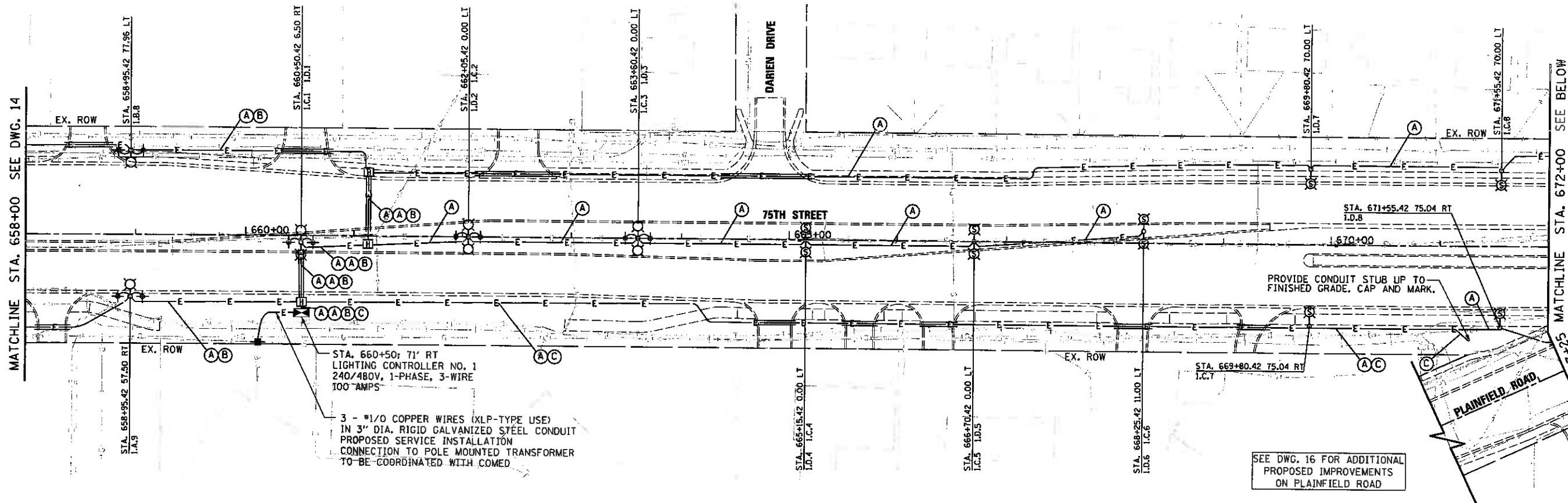

V3 Companies
 7325 Janes Avenue
 Woodridge, IL 60517
 830.724.9200 phone
 830.724.9202 fax
 www.v3co.com

USER NAME : jbour	DESIGNED - JDH	REVISED -
PLOT SCALE = 50.0000' / 1"	DRAWN - DRP	REVISED -
PLOT DATE = 3/10/2015	CHECKED - VJD	REVISED -
	DATE - 02/11/15	REVISED -

STATE OF ILLINOIS
 DEPARTMENT OF TRANSPORTATION

LIGHTING AND ELECTRICAL PLAN
 75TH STREET
 SCALE: 1"=50'
 SHEET NO. 2 OF 3 SHEETS STA. 658+00 TO STA. 686+00

F.A.P. RTE.	SECTION	COUNTY	TOTAL SHEETS	SHEET NO.
0369	15-00233-07-LT	DU PAGE	29	14
FED. ROAD DIST. NO. 1 ILLINOIS FED. AID PROJECT			CONTRACT NO. -----	



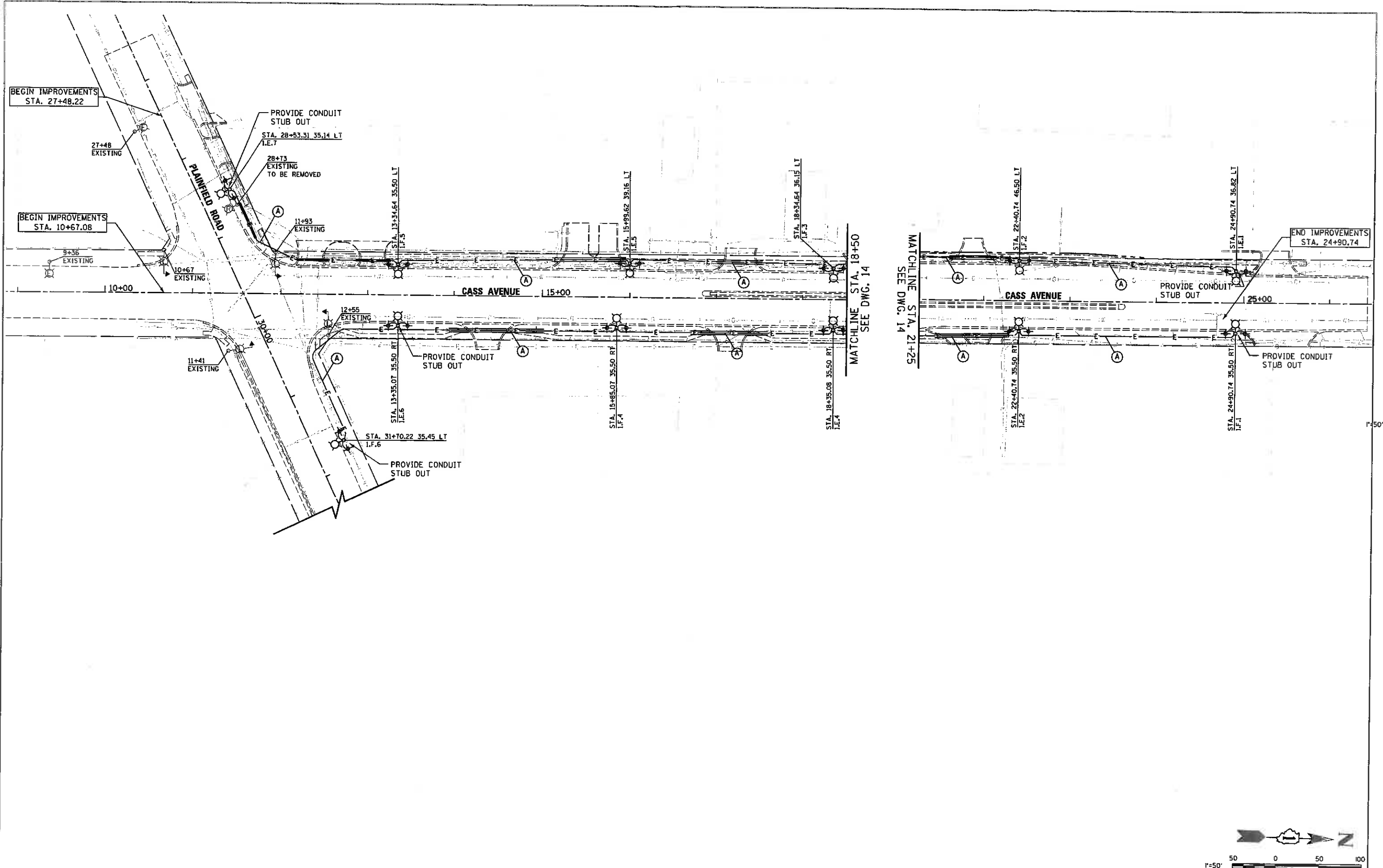

 V3 Companies
 7325 Jones Avenue
 Woodridge, IL 60517
 630.724.9200 phone
 630.724.9202 fax
 www.v3co.com

USER NAME = jbauer	DESIGNED - JDH	REVISED - ---
PLAT SCALE = 50.0000' / 1" =	DRAWN - DRP	REVISED - ---
PLAT DATE = 3/18/2015	CHECKED - VJD	REVISED - ---
	DATE - 02/17/15	REVISED - ---

STATE OF ILLINOIS
DEPARTMENT OF TRANSPORTATION





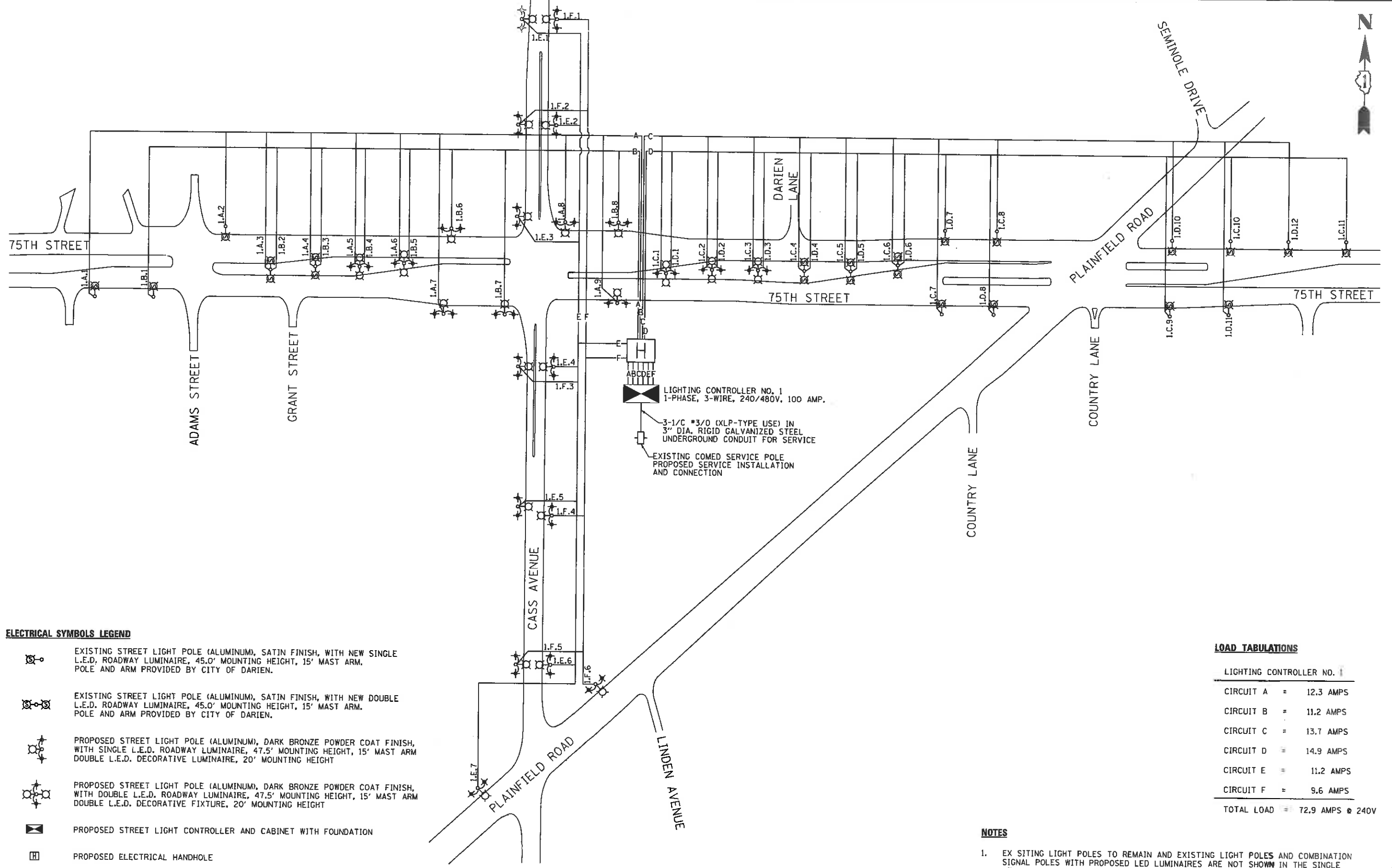

LIGHTING AND ELECTRICAL PLAN
CASS AVENUE

SCALE: 1"=50'
 SHEET NO. 3 OF 3 SHEETS STA. 08+00 TO STA. 30+00

F.A.P. RTE.	SECTION	COUNTY	TOTAL SHEETS	SHEET NO.
0369	15-00233-07-LT	DU PAGE	29	15
FED. ROAD DIST. NO. 1 ILLINOIS FED. AID PROJECT			CONTRACT NO. -----	



ELECTRICAL SYMBOLS LEGEND

-  EXISTING STREET LIGHT POLE (ALUMINUM), SATIN FINISH, WITH NEW SINGLE L.E.D. ROADWAY LUMINAIRE, 45.0' MOUNTING HEIGHT, 15' MAST ARM, POLE AND ARM PROVIDED BY CITY OF DARIEN.
-  EXISTING STREET LIGHT POLE (ALUMINUM), SATIN FINISH, WITH NEW DOUBLE L.E.D. ROADWAY LUMINAIRE, 45.0' MOUNTING HEIGHT, 15' MAST ARM, POLE AND ARM PROVIDED BY CITY OF DARIEN.
-  PROPOSED STREET LIGHT POLE (ALUMINUM), DARK BRONZE POWDER COAT FINISH, WITH SINGLE L.E.D. ROADWAY LUMINAIRE, 47.5' MOUNTING HEIGHT, 15' MAST ARM
-  PROPOSED STREET LIGHT POLE (ALUMINUM), DARK BRONZE POWDER COAT FINISH, WITH DOUBLE L.E.D. ROADWAY LUMINAIRE, 47.5' MOUNTING HEIGHT, 15' MAST ARM
-  PROPOSED STREET LIGHT CONTROLLER AND CABINET WITH FOUNDATION
-  PROPOSED ELECTRICAL HANDHOLE

LOAD TABULATIONS

LIGHTING CONTROLLER NO. 1	
CIRCUIT A	= 12.3 AMPS
CIRCUIT B	= 11.2 AMPS
CIRCUIT C	= 13.7 AMPS
CIRCUIT D	= 14.9 AMPS
CIRCUIT E	= 11.2 AMPS
CIRCUIT F	= 9.6 AMPS
TOTAL LOAD	= 72.9 AMPS @ 240V

NOTES

- EX SITING LIGHT POLES TO REMAIN AND EXISTING LIGHT POLES AND COMBINATION SIGNAL POLES WITH PROPOSED LED LUMINAIRES ARE NOT SHOWN IN THE SINGLE LINE WIRING DIAGRAM. THOSE LOCATIONS ARE CONTROLLED BY OTHER EXISTING CONTROLLERS.



V3 Companies 7325 James Avenue Woodridge, IL 60517 630.724.9200 phone 630.724.9202 fax www.v3co.com	USER NAME = jbauer DESIGNED - JDH DRAWN - DRP CHECKED - VJD DATE - 02/17/15	REVISED - --- REVISED - --- REVISED - --- REVISED - ---
--	---	--

STATE OF ILLINOIS
DEPARTMENT OF TRANSPORTATION

SINGLE LINE WIRING DIAGRAM

SCALE: NTS SHEET NO. 1 OF 1 SHEETS

F.A.P. RTE.	SECTION	COUNTY	TOTAL SHEETS	SHEET NO.
0369	15-00233-07-LT	DU PAGE	29	16
FED. ROAD DIST. NO. 1 ILLINOIS FED. AID PROJECT			CONTRACT NO. -----	

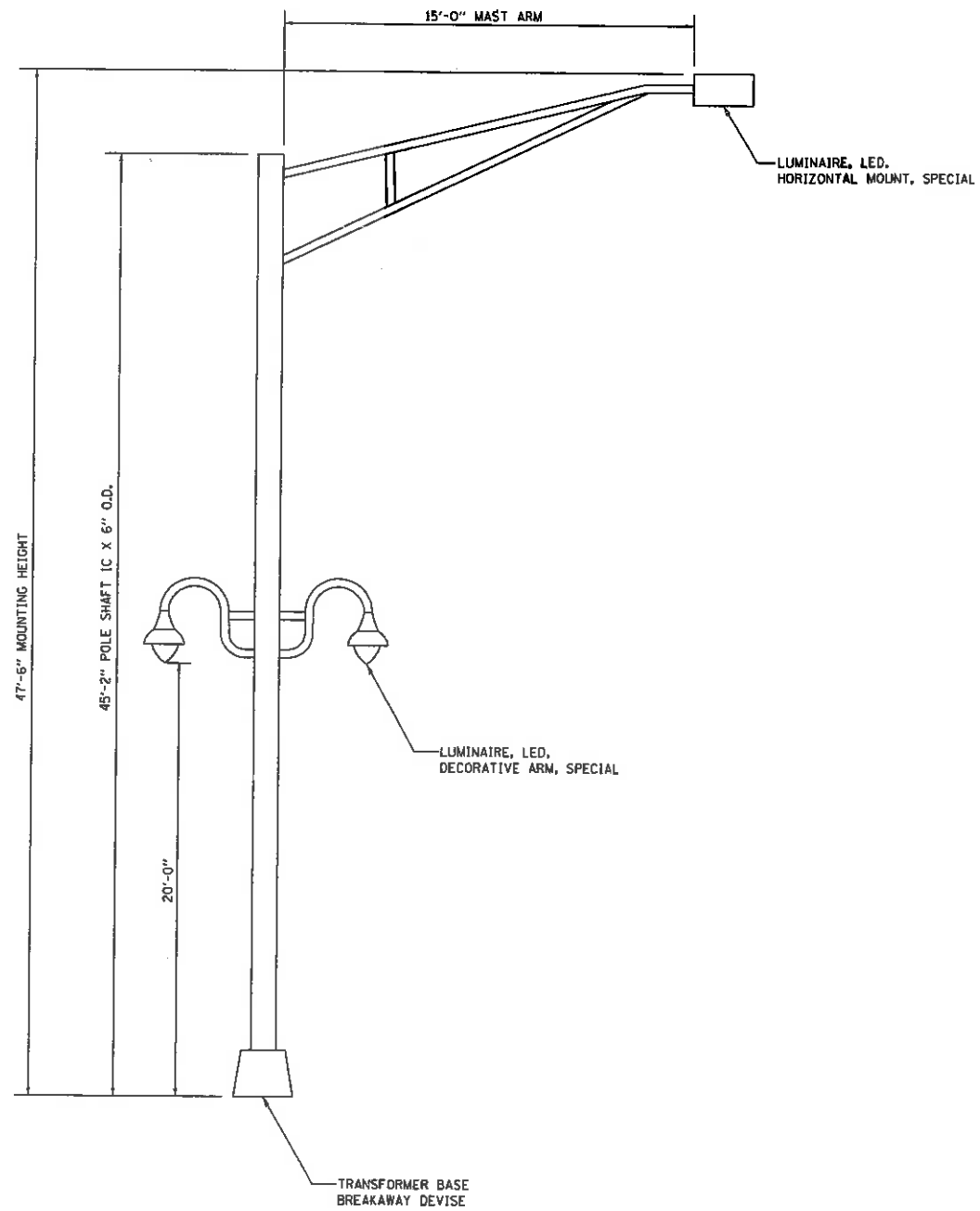

LIGHT POLE, ALUMINUM, 47.5 FT. M.H., 15 FT. MAST ARM
LUMINAIRE, LED, HORIZONTAL MOUNT, SPECIAL, 1 EACH
LUMINAIRE, LED, DECORATIVE ARM, SPECIAL, 2 EACH

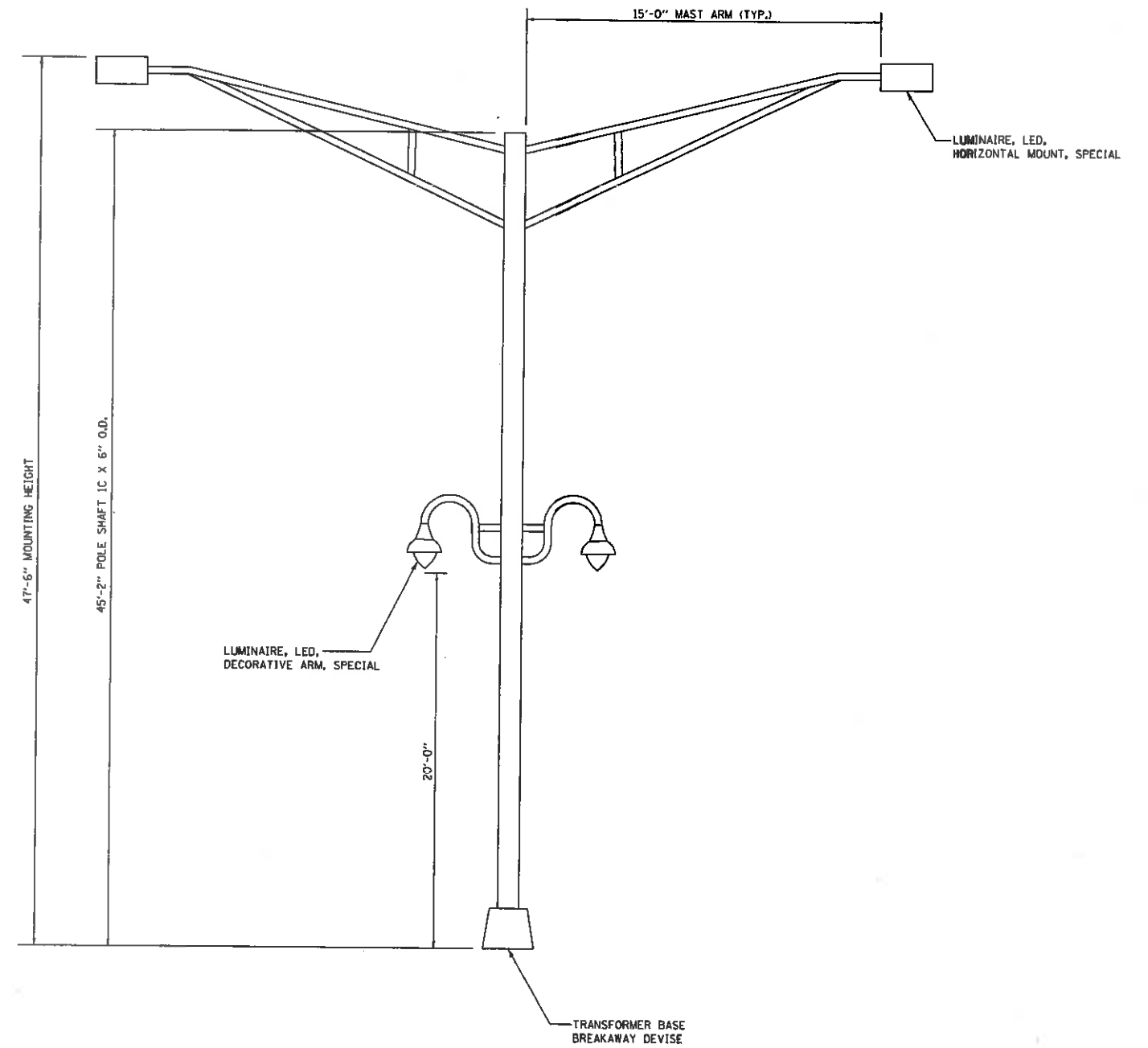

LIGHT POLE, ALUMINUM, 47.5 FT. M.H., 2-15 FT. MAST ARMS
LUMINAIRE, LED, HORIZONTAL MOUNT, SPECIAL, 2 EACH
LUMINAIRE, LED, DECORATIVE ARM, SPECIAL, 2 EACH

NOTES:

- SEE DUPAGE COUNTY COMMERCIAL STREET LIGHT DETAIL ON DRAWING 30 FOR ADDITIONAL LIGHT POLE INFORMATION.

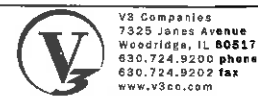

V3 Companies 7325 Jones Avenue Woodridge, IL 60517 630.724.9200 phone 630.724.9202 fax www.v3co.com	USER NAME = jbeuer	DESIGNED - JDH	REVISED - ---
		DRAWN - DRP	REVISED - ---
	PLOT SCALE = 80.0000' / 1"	CHECKED - VJD	REVISED - ---
	PLOT DATE = 3/10/2015	DATE - 02/17/15	REVISED - ---

STATE OF ILLINOIS
DEPARTMENT OF TRANSPORTATION

LIGHTING AND ELECTRICAL DETAILS

SCALE: NTS SHEET NO. 1 OF 1 SHEETS

F.A.P. RTE.	SECTION	COUNTY	TOTAL SHEETS	SHEET NO.
0369	15-00233-07-LT		29	17
FED. ROAD DIST. NO. 1 (ILLINOIS) FED. AID PROJECT		DU PAGE		CONTRACT NO. -----



Route 75th Street
 County DuPage
 Local Agency City of Darien
 Section 12-00233-07-It

(Construction) Estimate of Cost

Location and brief description (Sta. and land description of beginning; Sta. only for end for county and road districts; street limits for municipality.)
Lighting enhancements on 75th Street from S. Adams Street to Plainfield Road and Cass Avenue from Plainfield Road to 75th Street.
Improvements to include installation of LED street lighting fixtures, decorative lighting fixtures and poles and restoration.

Total Project Length	10,804'
Net Length	10,804'

Surface Type	Asphalt
Width	Varies

Shoulder Type	C&G
Width	N/A

Length	
Width	

Item Number	Items	Unit	Quantity	Unit Price	Total Cost	EEO % Breakdown
CARRIED FORWARD						
20201200	REMOVAL AND DISPOSAL OF UNSUITABLE MATERIAL	CU YD	25.0	\$ 30.00	\$ 750.00	0.11%
35101582	AGGREGATE BASE COURSE, TYPE B 2"	SQ YD	11.0	\$ 8.00	\$ 88.00	0.01%
35101800	AGGREGATE BASE COURSE, TYPE B 6"	SQ YD	11.0	\$ 10.00	\$ 110.00	0.02%
40603335	HOT-MIX ASPHALT SURFACE COURSE, MIX "D", N50	TON	3.0	\$ 125.00	\$ 375.00	0.06%
42400200	PORTLAND CEMENT CONCRETE SIDEWALK 5 INCH	SQ FT	100.0	\$ 10.00	\$ 1,000.00	0.15%
44000600	SIDEWALK REMOVAL	SQ FT	100.0	\$ 8.00	\$ 800.00	0.12%
66900200	NON-SPECIAL WASTE DISPOSAL	CU YD	16.0	\$ 85.00	\$ 1,360.00	0.21%
66900530	SOIL DISPOSAL ANALYSIS	EACH	1.0	\$ 1.00	\$ 1.00	0.00%
67100100	MOBILIZATION	LSUM	1.0	\$ 25,000.00	\$ 25,000.00	3.80%
80400100	ELECTRIC SERVICE INSTALLATION	EACH	1.0	\$ 2,000.00	\$ 2,000.00	0.30%
80400200	ELECTRIC UTILITY SERVICING CONNECTION	LSUM	1.0	\$ 15,000.00	\$ 15,000.00	2.28%
81028220	UNDERGROUND CONDUIT, GALVANIZED STEEL, 3" DIA.	FOOT	3,669.0	\$ 23.00	\$ 84,387.00	12.84%
81028740	UNDERGROUND CONDUIT, COILABLE NONMETALLIC CONDUIT, 1 1/2" DIA.	FOOT	1,092.0	\$ 8.00	\$ 8,736.00	1.33%
81400100	HANDHOLE	EACH	6.0	\$ 1,000.00	\$ 6,000.00	0.91%
81603078	UNIT DUCT, 600V, 3-1C NO.2, 1/C NO.2 GROUND, (XLP-TYPE USE), 1 1/2" DIA. POLYETHYLENE	FOOT	3,535.0	\$ 14.00	\$ 49,490.00	7.53%
81603085	UNIT DUCT, 600V, 3-1C NO.4, 1/C NO.4 GROUND, (XLP-TYPE USE), 1 1/4" DIA. POLYETHYLENE	FOOT	9,100.0	\$ 12.00	\$ 109,200.00	16.61%
81702160	ELECTRIC CABLE IN CONDUIT, 600V (XLP-TYPE USE) 1/C NO. 1/0	FOOT	60.0	\$ 8.00	\$ 480.00	0.07%
82500350	LIGHTING CONTROLLER, BASE MOUNTED, 240VOLT, 100AMP	EACH	1.0	\$ 10,000.00	\$ 10,000.00	1.52%
83050810	LIGHT POLE, ALUMINUM, 47.5 FT. M.H., 15 FT. MAST ARM	EACH	19.0	\$ 3,000.00	\$ 57,000.00	8.67%
83050910	LIGHT POLE, ALUMINUM, 47.5 FT. M.H., 2-15 FT. MAST ARMS	EACH	5.0	\$ 3,200.00	\$ 16,000.00	2.43%
<input checked="" type="checkbox"/> Page Total <input type="checkbox"/> Total Estimated Cost					\$ 387,777.00	58.99%

Made by JWB
 Checked by VJD

Date 3/10/2015
 Date 3/10/2015

75th Street Light Pole Installation and Lighting Enhancements

City of Darien
 75th Street (CH33), Adams Street to Plainfield Road & Cass Avenue, Plainfield Road to 75th Street
 Section No. 15-00233-07-LT
 DuPage County

Prepared By: V3 Companies
 Calc: JWB
 Check: VJD

Pre-Final (95%) Estimate of Cost
 3/10/2015

SUMMARY OF QUANTITIES			UNIT	TOTAL QTY	UNIT PRICE	CONSTRUCTION TYPE CODE		TOTAL COST	80% FEDERAL / 20% CITY OF DARIEN COST	100% CITY OF DARIEN COST
		80% FEDERAL / 20% CITY OF DARIEN LIGHTING				100% CITY OF DARIEN LIGHTING				
		D021				NON-PARTICIPATING				
85600200	LIGHT POLE FOUNDATION, 24" DIAMETER		FOOT	378	\$ 150.00	378		\$ 56,700.00	\$ 56,700.00	\$ -
* 85900205	BREAKAWAY DEVICE, TRANSFORMER BASE, 15 INCH BOLT CIRCLE		EACH	42	\$ 100.00	42		\$ 4,200.00	\$ 4,200.00	\$ -
84200800	REMOVAL OF LIGHTING UNIT, NO SALVAGE		EACH	1	\$ 250.00	1		\$ 250.00	\$ 250.00	\$ -
84200804	REMOVAL OF POLE FOUNDATION		EACH	1	\$ 150.00	1		\$ 150.00	\$ 150.00	\$ -
* 85000200	MAINTENANCE OF EXISTING TRAFFIC SIGNAL INSTALLATION		EACH	1	\$ 2,000.00	1		\$ 2,000.00	\$ 2,000.00	\$ -
89502300	REMOVE ELECTRIC CABLE FROM CONDUIT		FOOT	750	\$ 0.75	750		\$ 562.50	\$ 562.50	\$ -
* X0326617	PAINTING LIGHT POLE UNIT		EACH	24	\$ 400.00		24	\$ 9,600.00	\$ -	\$ 9,600.00
* X0327036	BIKE PATH REMOVAL		SQ YD	11	\$ 8.00	11		\$ 88.00	\$ 88.00	\$ -
* X2130010	EXPLORATION TRENCH, SPECIAL		FOOT	100	\$ 20.00	100		\$ 2,000.00	\$ 2,000.00	\$ -
* X7010216	TRAFFIC CONTROL AND PROTECTION (SPECIAL)		LSUM	1	\$ 19,000.00	1		\$ 19,000.00	\$ 19,000.00	\$ -
* X6211125	LUMINAIRE, LED, HORIZONTAL MOUNT, SPECIAL		EACH	75	\$ 800.00	75		\$ 60,000.00	\$ 60,000.00	\$ -
* X6380215	LIGHT POLE FOUNDATION, 24" DIAMETER, OFFSET		FOOT	1	\$ 700.00	1		\$ 700.00	\$ 700.00	\$ -
Z0013796	CONSTRUCTION LAYOUT		LSUM	1	\$ 13,000.00	1		\$ 13,000.00	\$ 13,000.00	\$ -
*	REMOVAL OF LUMINAIRE, SALVAGE		EACH	23	\$ 100.00	23		\$ 2,300.00	\$ 2,300.00	\$ -
*	LUMINAIRE, LED, DECORATIVE ARM, SPECIAL		EACH	48	\$ 1,800.00		48	\$ 86,400.00	\$ -	\$ 86,400.00
*	LIGHT POLE, ALUMINUM, 47.5 FT. M.H., 15 FT. MAST ARM (INSTALL ONLY)		EACH	13	\$ 700.00		13	\$ 9,100.00	\$ -	\$ 9,100.00
*	LIGHT POLE, ALUMINUM, 47.5 FT. M.H., 2-15 FT. MAST ARMS (INSTALL ONLY)		EACH	5	\$ 700.00		5	\$ 3,500.00	\$ -	\$ 3,500.00

TOTAL CONSTRUCTION COST	\$ 657,327.50	\$ 548,727.50	\$ 108,600.00
--------------------------------	---------------	---------------	---------------

LOCAL TOTAL COSTS	\$ 218,345.50	\$ 108,745.50	\$ 108,600.00
FEDERAL TOTAL COSTS	\$ 438,982.00	\$ 438,982.00	\$ -

75th Street Light Pole Installation and Lighting Enhancements

City of Darien
 75th Street (CH33), Adams Street to Plainfield Road & Cass Avenue, Plainfield Road to 75th Street
 Section No. 15-00233-07-LT
 DuPage County

Prepared By: V3 Companies
 Calc: JWB
 Check: VJD

Pre-Final (95%) Estimate of Cost
 3/10/2015

SUMMARY OF QUANTITIES						CONSTRUCTION TYPE CODE		TOTAL COST	80% FEDERAL / 20% CITY OF DARIEN COST	100% CITY OF DARIEN COST
	UNIT	TOTAL QTY	UNIT PRICE	80% FEDERAL /	100% CITY OF DARIEN					
				20% CITY OF DARIEN	LIGHTING	LIGHTING				
						0021	NON-PARTICIPATING			
20201200	REMOVAL AND DISPOSAL OF UNSUITABLE MATERIAL	CU YD	25	\$ 30.00		25		\$ 750.00	\$ 750.00	\$ -
35101582	AGGREGATE BASE COURSE, TYPE B 2"	SQ YD	11	\$ 8.00		11		\$ 88.00	\$ 88.00	\$ -
35101800	AGGREGATE BASE COURSE, TYPE B 6"	SQ YD	11	\$ 10.00		11		\$ 110.00	\$ 110.00	\$ -
40803335	HOT-MIX ASPHALT SURFACE COURSE, MX 'D', N50	TON	3	\$ 125.00		3		\$ 375.00	\$ 375.00	\$ -
42400200	PORTLAND CEMENT CONCRETE SIDEWALK 5 INCH	SQ FT	100	\$ 10.00		100		\$ 1,000.00	\$ 1,000.00	\$ -
44000600	SIDEWALK REMOVAL	SQ FT	100	\$ 8.00		100		\$ 800.00	\$ 800.00	\$ -
66900200	NON-SPECIAL WASTE DISPOSAL	CU YD	16	\$ 85.00		16		\$ 1,360.00	\$ 1,360.00	\$ -
66900530	SOIL DISPOSAL ANALYSIS	EACH	1	\$ 1.00		1		\$ 1.00	\$ 1.00	\$ -
67100100	MOBILIZATION	LSUM	1	\$ 25,000.00		1		\$ 25,000.00	\$ 25,000.00	\$ -
80400100	ELECTRIC SERVICE INSTALLATION	EACH	1	\$ 2,000.00		1		\$ 2,000.00	\$ 2,000.00	\$ -
* 80400200	ELECTRIC UTILITY SERVICING CONNECTION	LSUM	1	\$ 15,000.00		1		\$ 15,000.00	\$ 15,000.00	\$ -
81028220	UNDERGROUND CONDUIT, GALVANIZED STEEL, 3" DIA.	FOOT	3,669	\$ 23.00		3,669		\$ 84,387.00	\$ 84,387.00	\$ -
81028740	UNDERGROUND CONDUIT, COILABLE NONMETALLIC CONDUIT, 1 1/2" DIA.	FOOT	1,092	\$ 8.00		1,092		\$ 8,736.00	\$ 8,736.00	\$ -
81400100	HANDHOLE	EACH	6	\$ 1,000.00		6		\$ 6,000.00	\$ 6,000.00	\$ -
81603076	UNIT DUCT, 600V, 3-1C NO.2, 1/C NO.2 GROUND, (XLP-TYPE USE), 1 1/2" DIA. POLYETHYLENE	FOOT	3,535	\$ 14.00		3,535		\$ 49,490.00	\$ 49,490.00	\$ -
81603085	UNIT DUCT, 600V, 3-1C NO.4, 1/C NO.4 GROUND, (XLP-TYPE USE), 1 1/4" DIA. POLYETHYLENE	FOOT	9,100	\$ 12.00		9,100		\$ 109,200.00	\$ 109,200.00	\$ -
81702160	ELECTRIC CABLE IN CONDUIT, 600V (XLP-TYPE USE) 1/C NO. 1/0	FOOT	60	\$ 8.00		60		\$ 480.00	\$ 480.00	\$ -
82500350	LIGHTING CONTROLLER, BASE MOUNTED, 240VOLT, 100AMP	EACH	1	\$ 10,000.00		1		\$ 10,000.00	\$ 10,000.00	\$ -
83050810	LIGHT POLE, ALUMINUM, 47.5 FT. M.H., 15 FT. MAST ARM	EACH	19	\$ 3,000.00		19		\$ 57,000.00	\$ 57,000.00	\$ -
83050910	LIGHT POLE, ALUMINUM, 47.5 FT. M.H., 2-15 FT. MAST ARMS	EACH	5	\$ 3,200.00		5		\$ 16,000.00	\$ 16,000.00	\$ -

75th Street Corridor and Cass Avenue Corridor Cost Summary

DESCRIPTION	COSTS	FEDERAL SHARE	CITY SHARE
Design Engineering Cost	\$ 26,038.00	\$ 20,830.40	\$ 5,207.60
Estimated Construction Cost	\$ 657,327.50	\$ 438,982.00	
20% Local Match for CMAQ eligible items			\$ 109,745.50
100% Differential Cost for Theme Lighting			\$ 108,600.00
Total Construction Costs	\$ 657,327.50	\$ 438,982.00	\$ 218,345.50
Estimated Construction Engineering	\$ 100,000.00	\$ 67,000.00	\$ 33,000.00
Totals	\$ 783,365.50	\$ 526,812.40	\$ 256,553.10
Contingency-Winter Engineering Costs	\$ 65,000.00	\$ 43,550.00	\$ 21,450.00
Totals With Contingency	\$ 848,365.50	\$ 570,362.40	\$ 278,003.10
City Budget FY15-16	\$ 238,000.00		
City Share Cost	\$ 256,553.10		
Contingency-Winter Engineering Costs	\$ 21,450.00		
Budget Remainder	\$ (40,003.10)		

Dan Gombac

From: Vince DelMedico <vdelmedico@v3co.com>
Sent: Thursday, April 16, 2015 3:02 PM
To: Dan Gombac
Cc: Tworek, David (David.Tworek@dupageco.org); Jason Holy
Subject: 75th Street Lighting Cost Estimate

Dan:

As a follow up to our conversation from earlier this week (with regard to the 75th Street Lighting pre-final cost estimate), V3 has gone back and taken another look at the estimated unit costs. Based on our review, we do not feel comfortable in reducing any of the suggested unit costs. We took the most in depth look at the decorative luminaire/arm cost (estimated at \$1800/each) and feel that it is appropriate based on the most recent conversations we have had with various lighting reps. Although V3 had initially estimated a unit cost of \$850 for this item, it was at the very early concept stage before we had an opportunity to discuss this item in detail with lighting reps. In addition, the initial cost had underestimated the cost associated with the decorative arm.

As another way to potentially reduce the overall project cost, the County is going to revisit the estimated construction engineering fee. Otherwise we may have to look at reducing the scope of the improvements proposed.

Please let me know if you have any questions. Thanks.

Vincent J. Del Medico, P.E.
Senior Project Manager

V3 Companies

7325 Janes Avenue | Woodridge, IL 60517
Direct: 630.729.6320 | Phone: 630.724.9200 | Fax: 630.724.9202 | Cell: 773.456.8531
vdelmedico@v3co.com | www.v3co.com

V3 | THE VISION TO TRANSFORM WITH EXCELLENCE



please consider the environment prior to printing

To receive important information from the City of Darien sign up for our electronic newsletter:

DARIEN DIRECT CONNECT

Follow the link below and subscribing is simple!

<http://www.darien.il.us/Departments/Administration/CityNews.html>

From: Dolan, Agnes [mailto:Agnes.Dolan@dupageco.org]

Sent: Friday, April 10, 2015 4:43 PM

To: Dan Gombac

Cc: Tworek, David; Krueger, Paul; Snyder, Christopher

Subject: IGA for Lighting Project - 75th Street

Dan,

Attached is a revised IGA based on the latest Estimate of Cost from the Pre-Final Plan submittal.

Also, per Dave Tworek:

1. The replacement of street lights on Plainfield Rd. (except at Cass) have been removed.
2. The banner arms have been deleted from the contract per Darien's request.
3. The decorative poles are not black, but actually a dark bronze.
4. The price of decorative lights were increased to \$1800 from the original estimate of \$850.
5. We will be re-using aluminum poles (removed before road construction) outside the commercial areas.

A copy of the latest Estimate of Cost is also attached hereto although I believe you have already received a copy from Dave or V3.

Exhibit B is also attached hereto/Permit conditions (see paragraph 7.2 added in agreement).

Please review the revised IGA and attachments herein and let me know if you have any comments so that we can work towards finalizing the agreement for execution. Please feel free to contact me or Dave if you should have any additional questions in your review of the revised IGA. Thank you.

Agnes Dolan
Agreements Coordinator
DuPage County Division of Transportation
421 N. County Farm Road
Wheaton, IL 60187
Main: (630) 407-6900
Facsimile: (630) 407-6901
Direct: (630) 407-6896



DuPage County
DANIEL J. CRONIN
COUNTY BOARD CHAIRMAN

DIVISION OF TRANSPORTATION

(630) 407-6900

FACSIMILE (630) 407-6901

EXHIBIT B PAGE 1 OF 3

PERMIT CONDITIONS:

1. Equipment and materials shall **NOT** be stored within the County's rights-of-way.
2. Existing sidewalk, curb/gutter and pavement disturbed or damaged due to the permitted work shall be replaced in kind as directed by the County Engineer, the duly authorized assign.
3. Pavement, curb/gutter and storm structures shall be maintained free of mud/debris at all times.
4. The Permittee, it's agent, successor, assign, and/or contractor shall furnish all material, labor, and pay all costs required to restore said County rights-of-way to a condition similar or equal to the conditions that existed before the commencement of the described work. It shall be the responsibility of the Permittee to properly grade, install a min. of 6" topsoil and seed (with erosion control blanket or hydro seeding) or sod (salt tolerant and staked in place) any portions of the rights-of-way disturbed during the described work.
5. Construction and erosion control measures shall comply with the minimum requirements of the "DuPage County Stormwater and Floodplain Ordinance" and any supplemental specifications made thereto.
6. The permitted improvements shall be located and constructed per the DuPage County standards and to the satisfaction of DuPage County Division of Transportation. The material used and method of construction shall comply with and conform to IDOT's "Standard Specifications for Road and Bridge Construction" (latest edition) and "Supplemental Specifications and Recurring Special Provisions" (latest edition).
7. The Permittee, it's agent, successor, assign, and/or contractor agrees to provide traffic control with advance warning signs, an arrow board and barricades conforming to the FHWA's "Manual on Uniform Traffic Control Devices" and IDOT's Highway Standards, "Standard Specifications for Road and Bridge Construction" (latest edition) and "Supplemental Specifications and Recurring Special Provisions" (latest edition) or as specified. The Permittee, it's agent, successor, assign, and/or contractor agrees to provide controlled flow of traffic at all times by approved detour or flag persons (with applicable warning signage) to minimize the inconvenience to traffic. Daily lane closures of County roadways are permitted Monday through Friday between 9:00 a.m. and 4:00 p.m. ONLY.
8. The Permittee, it's agent, successor, assign, and/or contractor assumes all risk and liability and agrees to defend, indemnify, and hold harmless the County of DuPage, its successors, assigns or employees, for any injury incurred to persons and/or damage to property in conjunction with and/or due to the permitted work/event.
9. The Permittee, it's agent, successor, assign, and/or contractor shall not trim, remove, or in any way disturb trees or shrubs along and/or within the highway or trail system rights-of-way without prior written approval by or from the DuPage County Division of Transportation.
10. The Permittee, it's agent, successor, assign, and/or contractor shall properly maintain all existing regulatory, warning and/or informational traffic control signage and/or devices along or within the DuPage County rights-of-way within the limits of the work covered under the permit and for the duration of said event permitted work/event. The DuPage County Division of Transportation shall be notified prior to construction and/or potential conflicts with existing signage due to the permitted construction. The Permittee, it's agent, successor, assign, and/or contractor furthermore shall reimburse the DuPage County Highway Maintenance Dept. for any relocation and/or replacement of, due to conflicts with and/or damage to, said signage, posts and/or equipment.
11. DuPage County reserves the right to make changes, additions and/or repairs to and relocations of, within its statutory limits, the facilities and/or their appurtenances constructed under this permit within the County rights-of-way as may at any time be considered necessary to permit the relocation, reconstruction, widening and/or maintaining of the highway, trail and/or path and/or to provide proper protection to life and property on or adjacent to the County rights-of-way. However, in the event this permit is granted to construct, locate, operate and/or maintain facilities on and/or within the County rights-of-way, the Permittee, it's agent, successor, assign, and/or contractor upon written notification from the County Engineer to the Permittee, shall perform such alterations or change of location of the facilities, solely at the permittee's cost as far as statutory authority dictates, without expense to DuPage County. Should the Permittee fail to make satisfactory arrangements to comply with said request within a reasonable time, DuPage County reserves the right to make such alterations to, change of location of and/or remove the facilities, and the Permittee, furthermore, shall pay for any costs incurred by DuPage County for said work.
12. The Permittee, it's agent, successor, assign, and/or contractor shall notify the DuPage County Division of Transportation a minimum of 48 hours prior to the start of construction, to arrange for any inspections and at the completion of the described work according to County procedures and/or policy.
13. The Permittee, it's agent, successor, assign, and/or contractor shall contact J.U.L.I.E. (1-800-892-0123) for utility locations a min. of 48 hours prior to the start of construction.
14. The Permittee, it's agent, successor, assign, and/or contractor agrees to reimburse the County for any costs incurred by DuPage County for any repair, relocation and/or adjustment to the traffic signals and related equipment that is in conflict with or is damaged due to the permitted work. All construction shall be coordinated with the County's Signal Coordinator. Contact the Division of Transportation pertaining to traffic signal related equipment at (630) 407-6900 a minimum of 48 hours prior to the start of construction to coordinate inspections.
15. The Permittee, it's agent, successor, assign, and/or contractor is required to contact the local agencies (including, but not limited to, municipal fire and police departments and the DuPage County Sheriff's Department) notifying them of all roadway construction or special event and traffic restrictions and/or temporary detours a minimum of 72 hours prior to the start of said construction/event.

PERMIT CONDITIONS:

Trench backfill for any excavation(s) shall be installed within the County rights-of-way per the attached County standard.

Open cutting of the roadway pavement is NOT permitted without the express written permission of the County Engineer or the duly authorized assign.

Contact the DuPage County Division of Transportation (630/407-6900) a minimum of 48 hours prior to the start of construction within ANY County right-of-way and within 300' on any side street adjacent to a County signalized highway intersection to request a location of the traffic signals and related equipment, including signal interconnection conduit/cable. The County's traffic signals and related equipment are NOT on the J.U.L.I.E. system.

LANE CLOSURES ARE NOT PERMITTED ON COUNTY ROADWAYS DURING SNOWFALL OR WITHIN 2 HOURS PRIOR TO PREDICTED SNOWFALL OR PRECIPITATION CONDITIONS BETWEEN NOVEMBER 15 AND APRIL 15 FOR MAINTENANCE OF THE ROADWAY PAVEMENT BY COUNTY HIGHWAY MAINTENANCE DEPARTMENT STAFF AND EQUIPMENT.

The Permittee, it's agent, successor, assign, and/or contractor agrees to provide as-built 'Record Drawings' of all improvements within and 100' adjacent to the County's rights-of-way to the County in a digital format (compatible with the County's AutoCAD system) upon their completion.

The Permittee, it's agent, successor, assign, and/or contractor agrees to assume sole responsibility for the maintenance of and liability for the permitted installation/construction.

The Permittee, it's agent, successor, assign, and/or contractor agrees to adjust, modify, relocate or remove the permitted items within sixty- (60) days of receipt of written notification as directed by the County to the Permittee.

****This permit is perpetual and thus the conditions stated herein and attached to the permit are without expiration, regardless of release of the bond posted and/or permit and/or acceptance of the construction/installation as permitted.***

PERMIT CONDITIONS:

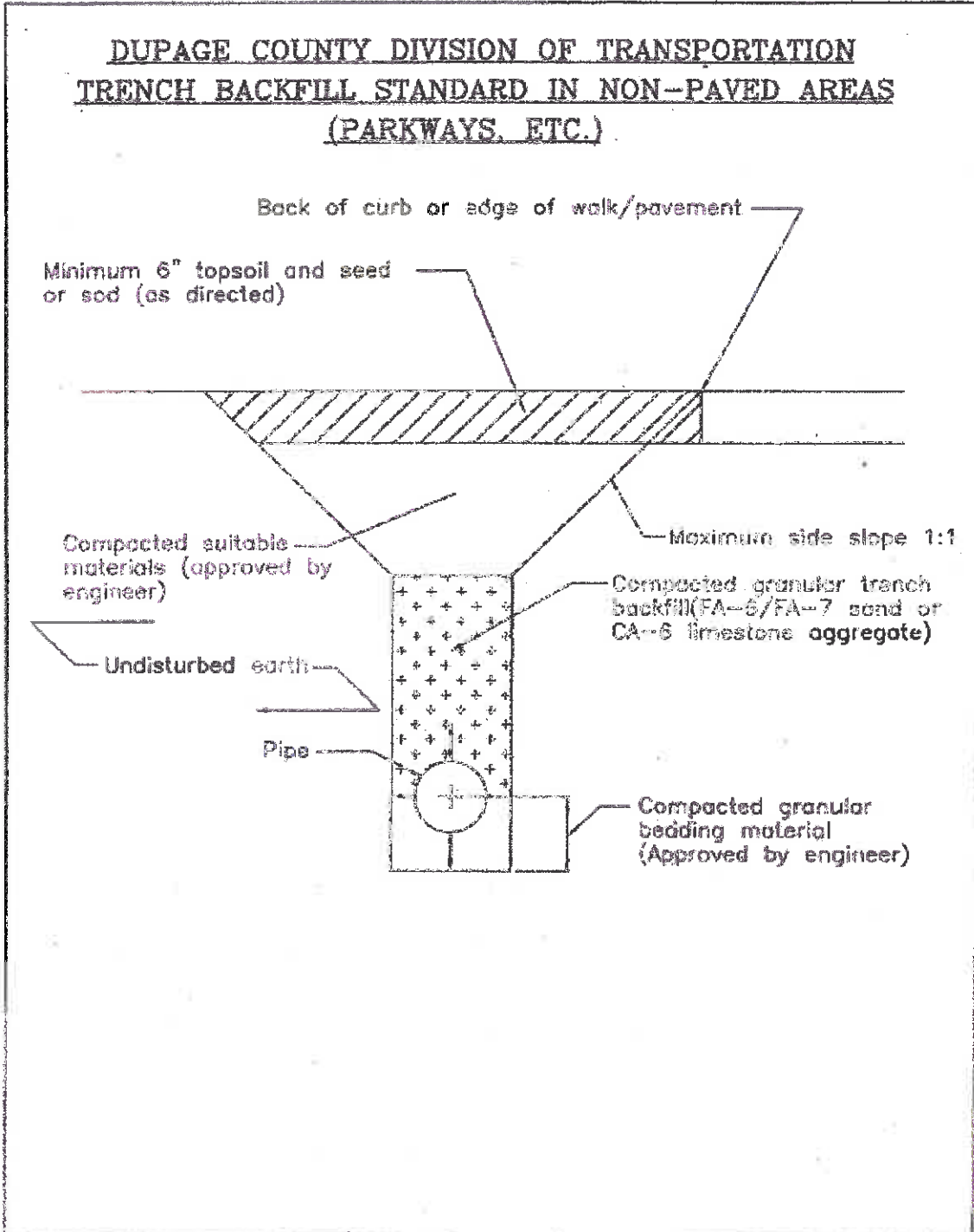

RESOLUTION NO. _____

A RESOLUTION AUTHORIZING THE MAYOR TO EXECUTE AND INTERGOVERNMENTAL AGREEMENT WITH THE COUNTY OF DUPAGE FOR THE PURPOSE OF SHARING COSTS FOR DESIGN AND CONSTRUCTION ENGINEERING, IDOT LETTING AND CONSTRUCTION FOR THE STREET LIGHTING PROJECT WITHIN LIMITED LOCATIONS OF THE 75TH STREET CORRIDOR AND THE CASS AVENUE CORRIDOR

WHEREAS, under the Constitution and Statutes of the State of Illinois, a municipality is authorized to participate in intergovernmental cooperation; and

WHEREAS, The Corporate Authorities, for record keeping, desire to authorize the execution of the Intergovernmental Agreement by Resolution.

NOW, THEREFORE, BE IT RESOLVED BY THE CITY COUNCIL OF THE CITY OF DARIEN, DUPAGE COUNTY, as follows:

SECTION 1: That the Mayor is hereby authorized to execute an Intergovernmental Agreement for the purpose of sharing costs for design and construction engineering, IDOT Letting and Construction for the Street Lighting Project within limited locations of the 75th Street corridor and the Cass Avenue corridor. The obligations of the City of Darien shall be limited to those specifically stated within the terms of the Intergovernmental Agreement.

SECTION 2: This Resolution shall be in full force and effect from and after its passage and approval as provided by law.

PASSED BY THE CITY COUNCIL OF THE CITY OF DARIEN, DUPAGE COUNTY, ILLINOIS, this 4th day of May, 2015.

AYES: _____

NAYS: _____

ABSENT: _____

RESOLUTION NO. _____

APPROVED BY THE MAYOR FOR THE CITY OF DARIEN, DUPAGE COUNTY, ILLINOIS, this 4th day of May, 2015.

KATHLEEN MOESLE WEAVER, MAYOR

ATTEST:

JOANNE E. RAGONA, CITY CLERK

APPROVED AS TO FORM:

CITY ATTORNEY

"REVISED DRAFT"
INTERGOVERNMENTAL AGREEMENT BETWEEN THE
COUNTY OF DU PAGE
AND
THE CITY OF DARIEN
FOR
STREET LIGHTING IMPROVEMENTS RELATING TO THE CONSTRUCTION OF
COUNTY HIGHWAY 33/75TH STREET
(ADAMS STREET TO PLAINFIELD ROAD)
SECTION NO. 15-00233-07-LT

This Intergovernmental Agreement (hereinafter referred to as "AGREEMENT") is entered into this ____ day of _____, 2015, between the County of DuPage (hereinafter referred to as the "COUNTY"), a body corporate and politic, with offices at 421 North County Farm Road, Wheaton, Illinois and the City of Darien (hereinafter referred to as the "CITY"), a municipal corporation with offices at 1702 Plainfield Road, Darien, Illinois. The COUNTY and the CITY are hereinafter sometimes individually referred to as a "party" or together as the "parties."

RECITALS

WHEREAS, the CITY in order to ~~facilitate the free flow of traffic and to ensure~~ the safety of the motoring public is desirous of replacing existing street lighting (hereinafter referred to as "STREET LIGHTING," Section 15-00233-07-LT) impacted by the construction of CH 33/75th Street, from Adams Street to Plainfield Road, County Section No. 12-00233-07-PV (hereinafter referred to as "PROJECT"); and

WHEREAS, the PROJECT is currently under construction and it has been determined that the STREET LIGHTING is eligible for federal Congestion Mitigation and Air Quality Improvement Program (CMAQ) funds currently obligated to the PROJECT; and

WHEREAS, CMAQ funds obligated for the PROJECT in excess of what is estimated to be necessary to complete the PROJECT can be redistributed to the STREET LIGHTING as a separate project; and

WHEREAS, the COUNTY's design consultant for the PROJECT has been directed to perform said STREET LIGHTING design work; and

WHEREAS, the COUNTY and the CITY desire to cooperate in the STREET LIGHTING because of the benefit of the STREETING LIGHTING to the residents of DuPage County, the CITY and the public; and

WHEREAS, the COUNTY and the CITY desire to establish the parties' mutual project, cost and maintenance responsibilities with respect to the STREET LIGHTING; and

WHEREAS, the COUNTY by virtue of its power set forth in "Counties Code" (55 ILCS 5/1-1001 et seq.) and "Illinois Highway Code" (605 ILCS 5/1-101 et seq.) and the CITY by virtue of its power set forth in the "Illinois Municipal Code" (65 ILCS 5/1-1-1 et seq.) are authorized to enter into this AGREEMENT; and

WHEREAS, a cooperative intergovernmental agreement is appropriate and such an agreement is authorized and encouraged by Article 7, Section 10 of the Illinois Constitution and Intergovernmental Cooperation Act (5 ILCS 220/1 et seq.).

NOW, THEREFORE, in consideration of the premises, the mutual covenants, terms, and conditions herein set forth, and the understandings of each party to the other, the parties do hereby mutually covenant, promise and agree as follows:

1.0 INCORPORATION.

1.1. All recitals set forth above are incorporated herein and made part hereof, the same constituting the factual basis for this AGREEMENT.

1.2. The headings of the paragraphs and subparagraphs of this AGREEMENT are inserted for convenience of reference only and shall not be deemed to constitute part of this AGREEMENT or to affect the construction thereof.

2.0 SCOPE OF STREET LIGHTING

2.1. The STREET LIGHTING includes, but is not limited to, street lighting along 75th Street between Adams Street and Plainfield Road and along Cass Avenue from 75th Street to Plainfield Road.

2.2. The design of the STREET LIGHTING will include painting the light poles, decorative treatments and new street lighting as requested by the CITY and subject to CITY cost share as noted herein below.

3.0 RESPONSIBILITIES - JOINT

- 3.1. The COUNTY and CITY agree to cooperate in and make every effort to cause the construction of the STREET LIGHTING.
- 3.2. The COUNTY and the CITY agree that the estimated cost of the STREET LIGHTING that includes design, construction and construction engineering is \$783,365.50, and the CITY's share is \$256,553.10 as shown on Exhibit A attached hereto and incorporated herein by reference.
- 3.3. The COUNTY and CITY agree that the contract documents for the STREET LIGHTING will be prepared in an effort to minimize the need to relocate CITY utilities. Should field conditions result in unexpected utility conflict(s), reasonably demonstrated to be the result on the information provided to the COUNTY from the CITY, all reasonable costs associated with resolving said utility conflict(s) shall be at the sole cost of the CITY.
- 3.4. The COUNTY and the CITY acknowledge that no right-of-way is required for the STREET LIGHTING.

4.0 RESPONSIBILITIES OF THE COUNTY

4.1. The COUNTY shall act as the lead agency and be responsible for completing all design engineering and coordination for a letting with IDOT as well as construction engineering for the STREET LIGHTING with reimbursement by the CITY as hereinafter referenced.

4.2. Both the COUNTY and CITY agree that the CITY reserves the right to request that IDOT not award the contract if the bid prices are unacceptable to the CITY for the STREET LIGHTING.

~~4.2.4.3.~~ Both the COUNTY and CITY agree that the COUNTY shall administer the contract for the construction of

Formatted: Indent: Left: 1.05", No bullets or numbering

the STREET LIGHTING. The COUNTY agrees to administer the STREET LIGHTING contract in the best interest of both parties and to consult with, and keep advised, officials of the CITY regarding the progress of the STREET LIGHTING and any problems encountered or changes recommended. No change order which affects the CITY's facilities, or CITY cost, except normal minor variations in quantities of pay items required to complete the STREET LIGHTING shall be authorized except with prior written or e-mail approval by the CITY.

~~4.3-~~4.4. The COUNTY shall submit the Pre-final Plans and Specifications for the STREET LIGHTING to the CITY for review. The CITY shall provide review comments within fourteen (14) days of receipt of the Pre-final Plans and Specifications. The COUNTY will correct any errors and address other reasonable comments prior to the submittal of Final Plans and Specifications to the CITY.

5.0 RESPONSIBILITIES OF THE CITY

~~5.1-~~5.1. The CITY shall immediately notify the COUNTY, in writing, if the bid is unacceptable to the CITY for the STREET LIGHTING and shall inform the COUNTY to reject the bid.

~~5.1-~~5.2. The CITY shall, upon completion and acceptance of the STREET LIGHTING own, operate, and maintain the STREET LIGHTING and be financially responsible to repair, relocate, and replace the STREET LIGHTING, if necessary, due to future roadway improvements. Acceptance of the STREET LIGHTING shall not be unreasonably withheld by the CITY.

~~5.2-~~5.3. The CITY also agrees that upon completion and acceptance of the STREET LIGHTING, the CITY shall assume all future energy costs for the STREET LIGHTING and will be invoiced directly by the energy provider. The parties acknowledge that the STREET LIGHTING is separate from the COUNTY's combination poles at signalized intersections within the PROJECT.

~~5.3-~~5.4. The CITY shall assign a representative to the STREET LIGHTING construction to inspect the work and

consult with the COUNTY or COUNTY's resident engineer on a regular basis.

~~5-4-5.5.~~ The CITY agrees to reimburse the COUNTY for the 20% local match of the CMAQ funding for design engineering (or balance not covered by CMAQ), in addition to the CITY's share of costs for construction/construction engineering as shown on Exhibit A based upon actual construction bid costs plus the cost of any additional items required as a part of the STREET LIGHTING authorized in writing or via email by the CITY and the final construction engineering costs, less any federal shares. The CITY agrees to pay the COUNTY eighty (80%) percent of the Total Estimate of CITY's Cost as referenced on Exhibit A upon submittal of an invoice. Upon completion and acceptance by the CITY of the STREET LIGHTING and based upon the documentation of final costs and quantities, submitted by the COUNTY and a final invoice, the CITY agrees to reimburse the COUNTY for the balance of the STREET LIGHTING cost within sixty (60) days of receipt of a properly documented invoice from the COUNTY. The CITY agrees that any elements of the STREET LIGHTING requested by the CITY that are not CMAQ eligible will be at 100% CITY cost.

6.0 INDEMNIFICATION

6.1. The COUNTY shall to the extent permitted by law, indemnify, hold harmless and defend the CITY, its officials, officers, employees, and agents from and against all liability, claims, suits, demands, proceedings and action, including costs, fees and expense of defense, arising from, growing out of, or related to, any loss, damage, injury, death, or loss or damage to property resulting from, or connected with, the COUNTY's negligent or willful acts, errors or omissions in its performance under this AGREEMENT to the extent permitted by law. The COUNTY does not hereby waive any defenses or immunity available to it with respect to third parties.

6.1.1. The COUNTY and the CITY acknowledge that the COUNTY has made no representations, assurances or guaranties regarding the COUNTY's

or any successor's or assign's authority and legal capacity to indemnify CITY as provided for in this AGREEMENT. In the event a court of competent jurisdiction holds that the COUNTY, or any successor or assign, is deemed to lack the lawful authority or ability to indemnify, defend or hold harmless the CITY, or any person or entity claiming a right through CITY, or in the event of change in the laws of the State of Illinois governing COUNTY's or any successor's or assign's indemnification authority, such occurrence(s) shall not affect the validity and enforceability of the remainder of this AGREEMENT or the parties rights and obligations provided for therein.

6.2. The CITY shall indemnify, hold harmless and defend the COUNTY, its officials, officers, employees, and agents from and against all liability, claims, suits, demands, proceedings and action, including costs, fees and expense of defense, arising from, growing out of, or related to, any loss, damage, injury, death, or loss or damage to property resulting from, or connected with, the CITY'S negligent or willful acts, errors or omissions in its performance under this AGREEMENT to the extent permitted by law. The CITY does not hereby waive any defenses or immunity available to it with respect to third parties.

6.3. Nothing contained herein shall be construed as prohibiting the COUNTY, its officials, directors, officers, agents and employees, from defending through the selection and use of their own agents, attorneys and experts, any claims, suits, demands, proceedings and actions brought against them. Pursuant to Illinois law, 55 ILCS 5/3-9005, any attorney representing the COUNTY, under this paragraph or paragraph 6.1, who is not already an Assistant State's Attorney, is to be appointed a Special Assistant State's Attorney, as provided in 55 ILCS 5/3-9008. The COUNTY'S participation in its defense shall not remove CITY'S duty to indemnify, defend, and hold the COUNTY harmless, as set forth above.

6.4. Neither party waives, by these indemnity requirements, any defenses or protections under the

Local Governmental and Governmental Employees Tort Immunity Act (745 ILCS 10/1 et seq.) or otherwise available to it, or to the other party, under the law.

- 6.5. Any indemnity as provided in this AGREEMENT shall not be limited by reason of the enumeration of any insurance coverage herein provided. The CITY'S and COUNTY'S indemnification under Section 6.0 hereof shall terminate when the PROJECT is completed and the CITY assumes its maintenance responsibilities as set forth in Section 5.1 hereof.

7.0 GENERAL

- 7.1 It is understood and agreed by the parties hereto that this AGREEMENT is intended to address mutual STREET LIGHTING cost and maintenance responsibilities and improvements requested by the CITY and no changes to existing highways and appurtenances maintenance and/or jurisdiction are proposed.
- 7.2 The parties agree that this AGREEMENT shall serve in lieu of a separate DuPage County Division of Transportation permit for the STREET LIGHTING. ~~and, by~~ execution of this AGREEMENT, the CITY agrees to be bound by the Highway Permit Conditions, attached hereto as Exhibit B and made a part hereof, and the DuPage County Highway Rights-of-Way Permit and Fee Ordinance (ODT-0001A-06) incorporated herein by reference and amended from time to time including all insurance requirements as they exist on the date of the execution of this AGREEMENT by the COUNTY.
- 7.3 Whenever in this AGREEMENT, approval or review of either the COUNTY or CITY is provided for, said approval or review shall not be unreasonably delayed or withheld.
- 7.4 In the event of a dispute between the COUNTY and CITY representatives in the preparation of the Plans and Specifications, or changes thereto, or in carrying out the terms of this AGREEMENT, the County Engineer of the COUNTY and the City Administrator of the CITY shall meet and resolve the issue.

- 7.5 No later than fourteen (14) days after the execution of this AGREEMENT, each party shall designate a representative to the other party who shall serve as the full time representative of said party during the carrying out of the construction of the STREET LIGHTING. Each representative shall have authority, on behalf of such party, to receive notices and make inspections relating to the work covered in this AGREEMENT. Representatives shall be readily available to the other party.
- 7.6 This AGREEMENT may be executed in two (2) or more counterparts, each of which shall be deemed an original and all of which shall be deemed one in the same instrument.

8.0 ENTIRE AGREEMENT

- 8.1 This AGREEMENT represents the entire AGREEMENT between the parties with respect to the STREET LIGHTING, and supersedes all previous communications or understandings whether oral or written.

9.0 NOTICES

- 9.1 Any notice required hereunder shall be deemed properly given to the party to be notified at the time it is personally delivered or mailed by certified mail, return receipt requested, postage prepaid, or sent by confirmed facsimile, to the party's address. The address of each party is as specified below; either party may change its address for receiving notices by giving notices thereof in compliance with the terms of this subsection.

City of Darien
1702 Plainfield Road
Darien, IL 60561
ATTN: Bryon D. Vana, City Administrator
Phone: 630.852.5000
Facsimile: 630.852.4709

County of DuPage
Division of Transportation

ATTN: Christopher C. Snyder, P.E.
Director of Transportation/County Engineer
421 N. County Farm Road
Wheaton, IL 60187
Phone: 630.407.6900
Facsimile: 630.407.6901

10.0 AMENDMENT, MODIFICATION OR TERMINATION OF THIS AGREEMENT

10.1 No modification or amendment to this AGREEMENT shall be effective until approved by the parties in writing.

11.0 ASSIGNMENT

11.1 This AGREEMENT shall be binding upon and inure to the benefit of the parties hereto, their successors and assigns.

12.0 GOVERNING LAW

12.1. This AGREEMENT shall be governed by the laws of the State of Illinois as to both interpretation and performance.

12.2. The forum for resolving any disputes concerning the parties' respective performance, or failure to perform, under this AGREEMENT, shall be the Judicial Circuit Court for DuPage County.

13.0 AUTHORITY TO EXECUTE/RELATIONSHIP

13.1 The parties hereto have read and reviewed the terms of this AGREEMENT and by their signature as affixed below represent that the signing party has the authority to execute this AGREEMENT and that the parties intend to be bound by the terms and conditions contained herein.

13.2 This AGREEMENT shall not be deemed or construed to create an employment, joint venture, partnership or other agency relationship between the parties.

14.0 SEVERABILITY

14.1 In the event, any provision of this AGREEMENT is held to be unenforceable or invalid for any reason, the enforceability thereof shall not affect the remainder of the AGREEMENT. The remainder of this AGREEMENT shall be construed as if not containing the particular provision and shall continue in full force, effect, and enforceability, in accordance with its terms.

15.0 FORCE MAJEURE

15.1 Neither party shall be liable for any delay or non-performance of their obligations caused by any contingency beyond their control including but not limited to Acts of God, war, civil unrest, strikes, walkouts, fires or natural disasters.

IN WITNESS whereof, the parties set their hands and seals as of the date first written above.

COUNTY OF DU PAGE

CITY OF DARIEN

Daniel J. Cronin, Chairman
DuPage County Board

Kathleen A. Weaver, Mayor

ATTEST:

Paul Hinds
County Clerk

Joanne E. Ragona
City Clerk

**EXHIBIT A
ESTIMATE OF CITY COST**

Design engineering:	\$ 26,038.00	
20% Local Match for CMAQ eligible items (or balance thereof):		\$ 5,207.60
Estimated construction cost:	\$657,327.50	
20% Local Match for CMAQ eligible items:		\$109,745.50
100% differential cost for enhanced lighting features:		\$108,600.00
Estimated construction engineering:	\$100,000.00	
* CITY's share is estimated at 33%:		\$ 33,000.00
TOTAL ESTIMATE OF CITY'S COST:		\$256,553.10

| * If the STREET LIGHTING is delayed beyond the current anticipated schedule and additional construction engineering is required, the CITY's share of construction engineering will be adjusted. The CITY's share of the final total construction engineering cost will be the balance not covered by CMAQ funding.

**EXHIBIT A
ESTIMATE OF CITY COST**

Design engineering:	\$ 26,038.00	
20% Local Match for CMAQ eligible items (or balance thereof):		\$ 5,207.60
Estimated construction cost:	\$657,327.50	
20% Local Match for CMAQ eligible items:		\$109,745.50
100% differential cost for enhanced lighting features:		\$108,600.00
Estimated construction engineering:	\$100,000.00	
* <u>CITY's share is estimated at 33%:</u>		<u>\$ 33,000.00</u>
TOTAL ESTIMATE OF CITY'S COST:		\$256,553.10

* If the STREET LIGHTING is delayed beyond the current anticipated schedule and additional construction engineering is required, the CITY's share of construction engineering will be adjusted. The CITY's share of the final total construction engineering cost will be the balance not covered by CMAQ funding.

75th Street Light Pole Installation and Lighting Enhancements

City of Durban
 75th Street (C153), Adams Street to Plainfield Road & Cass Avenue, Plainfield Road to 75th Street
 section No. 15-0023-07-L1
 DuPage County

Prepared By: VS Components
 Date: JWB
 Check: VJD

Pre-Final (95%) Estimate of Cost
 3/10/2015

ITEM NO.	DESCRIPTION	UNIT	TOTAL CITY	UNIT PRICE	CONSTRUCTION TYPE CODE			TOTAL COST	80% FEDERAL / 20% CITY OF DUREN COST	80% CITY OF DUREN COST
					80% FEDERAL / 20% CITY OF DUREN COST	80% FEDERAL / 20% CITY OF DUREN COST	80% FEDERAL / 20% CITY OF DUREN COST			
SUMMARY OF QUANTITIES										
2202120	REMOVAL AND DISPOSAL OF UNSUITABLE MATERIAL	CU YD	25	\$ 30.00	25	0	0	\$ 750.00	\$ 750.00	\$ -
3510132	AGGREGATE BASE COURSE, TYPE B 2"	SQ YD	11	\$ 8.00	11	0	0	\$ 88.00	\$ 88.00	\$ -
3510100	AGGREGATE BASE COURSE, TYPE B 6"	SQ YD	11	\$ 10.00	11	0	0	\$ 110.00	\$ 110.00	\$ -
4802385	HOT-LAY ASPHALT SURFACE COURSE, MKT. TY. NBR	TON	3	\$ 253.00	3	0	0	\$ 759.00	\$ 759.00	\$ -
4240220	PORTLAND CEMENT CONCRETE SIDEWALK 6 INCH	SQ FT	100	\$ 10.00	100	0	0	\$ 1,000.00	\$ 1,000.00	\$ -
4400060	SIDEWALK REMOVAL	SQ FT	100	\$ 8.00	100	0	0	\$ 800.00	\$ 800.00	\$ -
6900290	NON-SPECIAL WASTE DISPOSAL	CU YD	10	\$ 85.00	10	0	0	\$ 850.00	\$ 850.00	\$ -
6900290	SOIL DISPOSAL/ANALYSIS	EACH	1	\$ 1.00	1	0	0	\$ 1.00	\$ 1.00	\$ -
6710100	MOBILIZATION	LABOR	1	\$ 25,000.00	1	0	0	\$ 25,000.00	\$ 25,000.00	\$ -
8040100	ELECTRIC SERVICE INSTALLATION	EACH	1	\$ 2,000.00	1	0	0	\$ 2,000.00	\$ 2,000.00	\$ -
8040200	ELECTRIC UTILITY SERVICES CONNECTION	LABOR	1	\$ 15,000.00	1	0	0	\$ 15,000.00	\$ 15,000.00	\$ -
8100220	UNDERGROUND CONDUIT, GALVANIZED STEEL, 2" DIA.	FOOT	3,889	\$ 26.00	3,889	0	0	\$ 101,314.00	\$ 101,314.00	\$ -
6102240	UNDERGROUND CONDUIT, COILABLE NONMETALLIC CONDUIT, 1 1/2" DIA.	FOOT	1,092	\$ 9.00	1,092	0	0	\$ 9,828.00	\$ 9,828.00	\$ -
8140210	HAND-POLES	EACH	6	\$ 1,000.00	6	0	0	\$ 6,000.00	\$ 6,000.00	\$ -
8400075	UNIT DUCT, 600, 3-10 NO.2, 1/2" DIA. POLYETHYLENE	FOOT	3,628	\$ 14.00	3,628	0	0	\$ 50,792.00	\$ 50,792.00	\$ -
8100205	UNIT DUCT, 600, 3-10 NO.4, 1/2" DIA. POLYETHYLENE	FOOT	9,100	\$ 12.00	9,100	0	0	\$ 109,200.00	\$ 109,200.00	\$ -
8170210	ELECTRIC CABLE RE CONDUIT, 600V (ALP-TYPE USE) 1/2" NO. 10	FOOT	60	\$ 8.00	60	0	0	\$ 480.00	\$ 480.00	\$ -
8200290	LIGHTING CONTROLLER, BRASS MOUNTED, 240-VOLT, 100-AMP	EACH	1	\$ 400.00	1	0	0	\$ 400.00	\$ 400.00	\$ -
8300010	LIGHT POLE, ALUMINUM, 47.5 FT. M.H., 15 FT. MAST ARM	EACH	10	\$ 2,000.00	10	0	0	\$ 20,000.00	\$ 20,000.00	\$ -
8300010	LIGHT POLE, ALUMINUM, 47.5 FT. M.H., 2-10 FT. MAST ARMS	EACH	6	\$ 3,000.00	6	0	0	\$ 18,000.00	\$ 18,000.00	\$ -

75th Street Light Pole Installation and Lighting Enhancements

City of Darwin
 76th Street (C1333), Adams Street to Plainfield Road & Cass Avenue, Plainfield Road to 75th Street
 Section No. 18-00293-07-L1
 Darpage County

Prepared By:
 Calk
 Check

VS Cooperatives
 JWB
 YJD

Pre-Final (95%) Estimate of Cost
 3/10/2016

ITEM	SUMMARY OF QUANTITIES	UNIT	TOTAL QTY	UNIT PRICE	CONSTRUCTION TYPE CODE		TOTAL COST	80% FEDERAL / 20% CITY OF DARBEN COST	100% CITY OF DARBEN COST
					80% FEDERAL / 20% CITY OF DARBEN LIGHTING	NON-PARTICIPATING			
8000000	LIGHT POLE FOUNDATION, 36" DIAMETER	FOOT	378	\$ 150.00	578		\$ 56,700.00	\$ 56,700.00	\$ -
8000005	BREAKAWAY DEVICE, TRANSFORMER BRGE, 16 INCH BOLT CIRCLE	EACH	42	\$ 100.00	42		\$ 4,200.00	\$ 4,200.00	\$ -
8000000	REMOVAL OF LIGHTING UNIT, NO SALVAGE	EACH	1	\$ 250.00	1		\$ 250.00	\$ 250.00	\$ -
8000004	REMOVAL OF POLE FOUNDATION	EACH	1	\$ 150.00	1		\$ 150.00	\$ 150.00	\$ -
8000000	MAINTENANCE OF EXISTING TRAFFIC SIGNAL INSTALLATION	EACH	1	\$ 2,000.00	1		\$ 2,000.00	\$ 2,000.00	\$ -
8000200	REMOVE ELECTRIC CABLE FROM CONDUIT	FOOT	760	\$ 0.75	750		\$ 562.50	\$ 562.50	\$ -
8000507	PAINTING LIGHT POLE UNIT	EACH	24	\$ 400.00	24		\$ 9,600.00	\$ -	\$ 9,600.00
8000700	BRG WITH REMOVAL	SQ YD	11	\$ 8.00	11		\$ 88.00	\$ 88.00	\$ -
8000900	EXCAVATION TRENCH, SPECIAL	FOOT	100	\$ 20.00	100		\$ 2,000.00	\$ 2,000.00	\$ -
8001000	TRAFFIC CONTROL AND PROTECTION (SPECIAL)	LINE	1	\$ 10,000.00	1		\$ 10,000.00	\$ 10,000.00	\$ -
8001100	LUMINARE (LED), HORIZONTAL MOUNT, SPECIAL	EACH	75	\$ 600.00	75		\$ 45,000.00	\$ 45,000.00	\$ -
8001200	LIGHT POLE FOUNDATION, 36" DIAMETER, OFFSET	FOOT	1	\$ 700.00	1		\$ 700.00	\$ 700.00	\$ -
8001400	CONSTRUCTION LAYOUT	LINE	1	\$ 10,000.00	1		\$ 10,000.00	\$ 10,000.00	\$ -
8001500	REMOVAL OF LUMINARE, SALVAGE	EACH	25	\$ 100.00	25		\$ 2,500.00	\$ 2,500.00	\$ -
8001600	LUMINARE LER, DECORATIVE ARM, SPECIAL	EACH	45	\$ 1,800.00	45		\$ 81,000.00	\$ -	\$ 81,000.00
8001700	LIGHT POLE, ALUMINUM, 42.5 FT. H.H., 15 FT. MAST ARM (INSTALL ONLY)	EACH	10	\$ 700.00	10		\$ 7,000.00	\$ -	\$ 7,000.00
8001800	LIGHT POLE, ALUMINUM, 42.5 FT. H.H., 2-1/2 FT. W/ST ARMS (INSTALL ONLY)	EACH	5	\$ 700.00	5		\$ 3,500.00	\$ -	\$ 3,500.00
TOTAL CONSTRUCTION COST							\$ 549,792.50	\$ 549,792.50	\$ 98,400.00
LOCAL TOTAL COSTS							\$ 549,792.50	\$ 98,400.00	\$ 648,192.50
FEDERAL TOTAL COSTS							\$ -	\$ -	\$ -



DuPage County
DANIEL J. CRONIN
COUNTY BOARD CHAIRMAN

DIVISION OF TRANSPORTATION

(630) 407-6900

FACSIMILE (630) 407-6901

EXHIBIT B PAGE 1 OF 3

PERMIT CONDITIONS:

1. Equipment and materials shall **NOT** be stored within the County's rights-of-way.
2. Existing sidewalk, curb/gutter and pavement disturbed or damaged due to the permitted work shall be replaced in kind as directed by the County Engineer, the duly authorized assign.
3. Pavement, curb/gutter and storm structures shall be maintained free of mud/debris at all times.
4. The Permittee, it's agent, successor, assign, and/or contractor shall furnish all material, labor, and pay all costs required to restore said County rights-of-way to a condition similar or equal to the conditions that existed before the commencement of the described work. It shall be the responsibility of the Permittee to properly grade, install a min. of 6" topsoil and seed (with erosion control blanket or hydro seeding) or sod (salt tolerant and staked in place) any portions of the rights-of-way disturbed during the described work.
5. Construction and erosion control measures shall comply with the minimum requirements of the "DuPage County Stormwater and Floodplain Ordinance" and any supplemental specifications made thereto.
6. The permitted improvements shall be located and constructed per the DuPage County standards and to the satisfaction of DuPage County Division of Transportation. The material used and method of construction shall comply with and conform to IDOT's "Standard Specifications for Road and Bridge Construction" (latest edition) and "Supplemental Specifications and Recurring Special Provisions" (latest edition).
7. The Permittee, it's agent, successor, assign, and/or contractor agrees to provide traffic control with advance warning signs, an arrow board and barricades conforming to the FHWA's "Manual on Uniform Traffic Control Devices" and IDOT's Highway Standards, "Standard Specifications for Road and Bridge Construction" (latest edition) and "Supplemental Specifications and Recurring Special Provisions" (latest edition) or as specified. The Permittee, it's agent, successor, assign, and/or contractor agrees to provide controlled flow of traffic at all times by approved detour or flag persons (with applicable warning signage) to minimize the inconvenience to traffic. Daily lane closures of County roadways are permitted Monday through Friday between 9:00 a.m. and 4:00 p.m. ONLY.
8. The Permittee, it's agent, successor, assign, and/or contractor assumes all risk and liability and agrees to defend, indemnify, and hold harmless the County of DuPage, its successors, assigns or employees, for any injury incurred to persons and/or damage to property in conjunction with and/or due to the permitted work/event.
9. The Permittee, it's agent, successor, assign, and/or contractor shall not trim, remove, or in any way disturb trees or shrubs along and/or within the highway or trail system rights-of-way without prior written approval by or from the DuPage County Division of Transportation.
10. The Permittee, it's agent, successor, assign, and/or contractor shall properly maintain all existing regulatory, warning and/or informational traffic control signage and/or devices along or within the DuPage County rights-of-way within the limits of the work covered under the permit and for the duration of said event permitted work/event. The DuPage County Division of Transportation shall be notified prior to construction and/or potential conflicts with existing signage due to the permitted construction. The Permittee, it's agent, successor, assign, and/or contractor furthermore shall reimburse the DuPage County Highway Maintenance Dept. for any relocation and/or replacement of, due to conflicts with and/or damage to, said signage, posts and/or equipment.
11. DuPage County reserves the right to make changes, additions and/or repairs to and relocations of, within its statutory limits, the facilities and/or their appurtenances constructed under this permit within the County rights-of-way as may at any time be considered necessary to permit the relocation, reconstruction, widening and/or maintaining of the highway, trail and/or path and/or to provide proper protection to life and property on or adjacent to the County rights-of-way. However, in the event this permit is granted to construct, locate, operate and/or maintain facilities on and/or within the County rights-of-way, the Permittee, it's agent, successor, assign, and/or contractor upon written notification from the County Engineer to the Permittee, shall perform such alterations or change of location of the facilities, solely at the permittee's cost as far as statutory authority dictates, without expense to DuPage County. Should the Permittee fail to make satisfactory arrangements to comply with said request within a reasonable time, DuPage County reserves the right to make such alterations to, change of location of and/or remove the facilities, and the Permittee, furthermore, shall pay for any costs incurred by DuPage County for said work.
12. The Permittee, it's agent, successor, assign, and/or contractor shall notify the DuPage County Division of Transportation a minimum of 48 hours prior to the start of construction, to arrange for any inspections and at the completion of the described work according to County procedures and/or policy.
13. The Permittee, it's agent, successor, assign, and/or contractor shall contact J.U.L.I.E. (1-800-892-0123) for utility locations a min. of 48 hours prior to the start of construction.
14. The Permittee, it's agent, successor, assign, and/or contractor agrees to reimburse the County for any costs incurred by DuPage County for any repair, relocation and/or adjustment to the traffic signals and related equipment that is in conflict with or is damaged due to the permitted work. All construction shall be coordinated with the County's Signal Coordinator. Contact the Division of Transportation pertaining to traffic signal related equipment at (630) 407-6900 a minimum of 48 hours prior to the start of construction to coordinate inspections.
15. The Permittee, it's agent, successor, assign, and/or contractor is required to contact the local agencies (including, but not limited to, municipal fire and police departments and the DuPage County Sheriff's Department) notifying them of all roadway construction or special event and traffic restrictions and/or temporary detours a minimum of 72 hours prior to the start of said construction/event.

PERMIT CONDITIONS:

Trench backfill for any excavation(s) shall be installed within the County rights-of-way per the attached County standard.

Open cutting of the roadway pavement is NOT permitted without the express written permission of the County Engineer or the duly authorized assign.

Contact the DuPage County Division of Transportation (630/407-6900) a minimum of 48 hours prior to the start of construction within ANY County right-of-way and within 300' on any side street adjacent to a County signalized highway intersection to request a location of the traffic signals and related equipment, including signal interconnection conduit/cable. The County's traffic signals and related equipment are NOT on the J.U.L.I.E. system.

LANE CLOSURES ARE NOT PERMITTED ON COUNTY ROADWAYS DURING SNOWFALL OR WITHIN 2 HOURS PRIOR TO PREDICTED SNOWFALL OR PRECIPITATION CONDITIONS BETWEEN NOVEMBER 15 AND APRIL 15 FOR MAINTENANCE OF THE ROADWAY PAVEMENT BY COUNTY HIGHWAY MAINTENANCE DEPARTMENT STAFF AND EQUIPMENT.

The Permittee, it's agent, successor, assign, and/or contractor agrees to provide as-built 'Record Drawings' of all improvements within and 100' adjacent to the County's rights-of-way to the County in a digital format (compatible with the County's AutoCAD system) upon their completion.

The Permittee, it's agent, successor, assign, and/or contractor agrees to assume sole responsibility for the maintenance of and liability for the permitted installation/construction.

The Permittee, it's agent, successor, assign, and/or contractor agrees to adjust, modify, relocate or remove the permitted items within sixty- (60) days of receipt of written notification as directed by the County to the Permittee.

****This permit is perpetual and thus the conditions stated herein and attached to the permit are without expiration, regardless of release of the bond posted and/or permit and/or acceptance of the construction/installation as permitted.***

DUPAGE COUNTY DIVISION OF TRANSPORTATION
TRENCH BACKFILL STANDARD IN NON-PAVED AREAS
(PARKWAYS, ETC.)

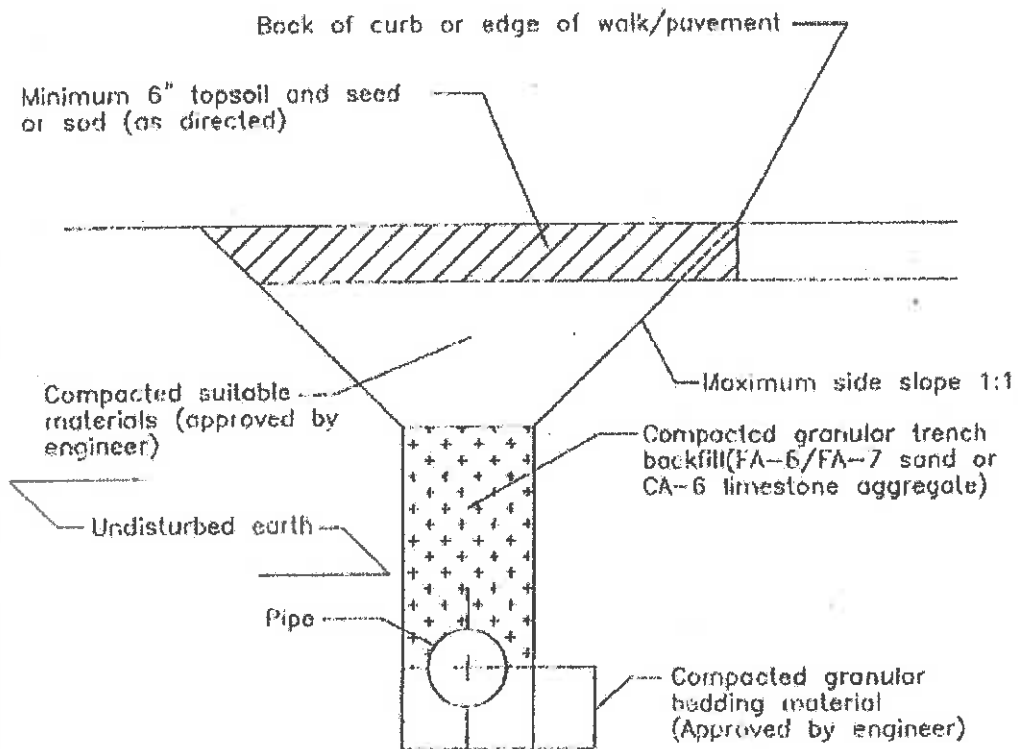

CITY OF DARIEN
MUNICIPAL SERVICES COMMITTEE
March 23, 2015

PRESENT: Joseph Marchese - Chairperson, Alderman Joerg Seifert, Alderman Tina Beilke,
Dan Gombac – Director

ABSENT: Michael Griffith – Senior Planner, Elizabeth Lahey - Secretary

ESTABLISH QUORUM

Chairperson Marchese called the meeting of the Municipal Services Committee to order at 6:30 p.m. at the City Hall – City Council Chambers, Darien, Illinois and declared a quorum present.

NEW BUSINESS

A. Ordinance - Wilmette Avenue and 69th Street - regulating parking and traffic control regulations at the Wilmette Avenue and 69th Street intersection.

Mr. Dan Gombac, Director reported that staff and the police worked on recommendations for the Wilmette Avenue and 69th Street. He reported that traffic control regulations would be implemented for the following:

1. On both sides of 69th Street from Wilmette Avenue west 300 feet, on the south side of 69th Street from Wilmette Avenue east 300 feet, on both sides of Wilmette Avenue between 69th Street and Hinsbrook Avenue “No Parking, Standing, Stopping signs from 2:30 p.m. – 3:30 p.m. on school days.”
2. For east bound traffic on 69th Street at Wilmette Avenue: “No Left Turn between 2:30 p.m. – 3:30 p.m. on school days.”

Alderman Seifert questioned how far back the cars presently stack.

Mr. Gombac reported that they stack on both the east and west and that cars cannot get through. He reported that staff felt that this was the most optimal solution.

Alderman Beilke questioned if there were any issues before school.

Mr. Gombac reported that the issues only occur during the pick-up hours.

Alderman Beilke stated that she was not thrilled with the signage language.

Mr. Gombac reported that the language is common terminology. He reported that staff will have to order the signs.

There was no one in the audience wishing to present public comment.

Alderman Seifert made a motion, and it was seconded by Alderman Beilke to approve consideration of an Ordinance regulating parking and traffic control regulations at the Wilmette Avenue and 69th Street intersection.

Upon voice vote, **THE MOTION CARRIED unanimously 3-0.**

B. Andermann Lane - Consideration of an Ordinance and Private Property Traffic Enforcement regulating parking on Andermann Lane.

Mr. Dan Gombac, Director reported that staff received complaints regarding vehicles parked on the private portion of Andermann lane on the Farmingdale Apartments property. He reported that the complaints are from the residents along Somerset Lane whose properties back up to the apartment complex.

Mr. Gombac reported that the Police Department worked with management and recommended prohibiting parking on the private portion of Anderman Lane. He reported that the Ordinance approves the Agreement which authorizes the City to post "No Parking" signs and allows Police enforcement of the signs.

Alderman Seifert stated that he is familiar with the area and there are more than 8-12 cars which is a nuisance. He stated that there is plenty of parking.

There was no one in the audience wishing to present public comment.

Alderman Seifert made a motion, and it was seconded by Alderman Beilke recommending approval of the proposed Ordinance and Private Property Traffic Enforcement Agreement regulating parking on Andermann Lane.

Upon voice vote, **THE MOTION CARRIED unanimously 3-0.**

C. Resolution - Authorizing the Mayor to execute a contract between the City of Darien and Muscat Painting and Decorating Inc. for the 2015 Fire Hydrant Painting Phase 2 in an amount not exceed \$33,859.00.

Mr. Dan Gombac, Director reported that this is the final phase of the Fire Hydrant Painting which started 3 years ago. He reported that in Phase 2 Muscat Painting and Decorating was the awarded vendor in 2014 and that they were terminated for lack of performance. He further reported that DMD Construction agreed to match the unit prices. Mr. Gombac reported that there is also a \$1,300 contingency and that the work should last approximately 12-15 years.

There was no one in the audience wishing to present public comment.

Alderman Seifert made a motion, and it was seconded by Alderman Beilke to approve a Resolution - Authorizing the Mayor to execute a contract between the City of Darien and DMD Construction. for the 2015 Fire Hydrant Painting Phase 2 in an amount not exceed \$33,859.00.

Upon voice vote, **THE MOTION CARRIED unanimously 3-0.**

D. Resolution – Authorizing the Mayor to execute a contract with Rag's Electric Company Inc. for the 2015/16 Street Light Maintenance Contract beginning May 1, 2015 through April 30, 2016.

Mr. Dan Gombac, Director reported that staff received three sealed bids for the 2015/16 street light maintenance contract. He reported that Lyons Electric was unresponsive and was disqualified. Mr. Gombac reported that he provided the Committee with the bid tabulation for costs to repair the street lights, hourly rates for labor, equipment, and lamp costs. He further reported that the tabulation includes a pricing schedule for two additional option years.

Mr. Gombac reported that this year's contract also called out for an option-LED Streetlight Retrofit Project. He reported that the street light inventory is currently 627 and the goal is to remove and replace 571 fixtures and a remainder of 56 light fixtures.

There was no one in the audience wishing to present public comment.

Alderman Seifert made a motion, and it was seconded by Alderman Beilke to approve Resolution – Authorizing the Mayor to execute a contract with Rag's Electric Company Inc. for the 2015/16 Street Light Maintenance Contract beginning May 1, 2015 through April 30, 2016.

Upon voice vote, THE MOTION CARRIED unanimously 3-0.

**E. Minutes - January 26, 2015 Municipal Services Committee
February 23, 2015 Municipal Services Committee**

Alderman Seifert made a motion, and it was seconded by Alderman Beilke to approve the January 26, 2015 Municipal Services Committee Meeting Minutes and the revised February 23, 2015 Municipal Services Committee Meeting Minutes.

Upon voice vote, THE MOTION CARRIED unanimously 3-0.

DIRECTOR'S REPORT

None.

NEXT SCHEDULED MEETING

Chairperson Marchese announced that the next regular meeting is scheduled for Monday, April 27, 2015 at 6:30 p.m.

ADJOURNMENT

With no further business before the Committee, Alderman Beilke made a motion and it was seconded by Alderman Seifert to adjourn. Upon voice vote, THE MOTION CARRIED unanimously and the meeting adjourned at 6:55 p.m.

RESPECTFULLY SUBMITTED:

Joseph Marchese
Chairman

Tina Beilke
Alderman

Joerg Seifert
Alderman